



## Pneumatics – technical information

**Pneumatics** – a scientific field dealing with the construction and use of devices in which the carrier of energy and signals is compressed air or a gas with similar properties, also called the working medium. Compressed air has a number of advantages over other energy sources, such as

- easy storage and transport,
- resistance to ambient temperature fluctuations,
- safe conditions of use (leaks into the environment are not harmful and do not constitute a fire hazard).

**Flow** – movement of a fluid, gas or liquid caused by a difference in pressure.

**Pneumatic drive** – this is a technique of moving the mechanisms of machines and devices with the use of compressed air energy.

**Pneumatic system** – a system in which compressed gas serves as a carrier of energy and information.

Features:

- long service life and reliability over a wide range of temperatures and environments,
- resistance to overloads,
- easy and stepless adjustments,
- easy operation, maintenance and repairs,
- low installation costs.

The use of pneumatic systems in the industry allows for comprehensive mechanisation and automation of production processes.

**Pneumatic cylinders** – are used as actuating elements in pneumatic systems, converting the energy transferred to them by the medium into mechanical energy. They are supplied with a working medium in the form of gas, which in most cases is compressed air. The offer of CPP "PREMA" S.A. includes both catalogue cylinders with linear motion (piston diameters from D12 to D320) as well as special cylinders manufactured to individual customer specifications. By selecting the correct piston diameter and working pressure in the pneumatic system, we can achieve the required force, from just several kN. The range of working strokes for the cylinders manufactured by CPP "PREMA" S.A. can range from a few millimetres to three metres. For swing cylinders, the angle of rotation is between 15 and 360 degrees.

**Distribution valves** – are used to control actuating elements in pneumatic drive systems. This is done by changing the direction of the working medium flow or by shutting it off. The valve is controlled by an external electrical, pneumatic or mechanical signal. Distribution valves are selected by adjusting the port size to the preset flow of the working medium and by selecting their functions, depending on the type of the controlled cylinder.

Connection markings on the symbol:

- 1 - working medium supply
- 2, 4 - receivers
- 3, 5 - vents

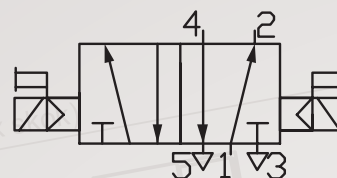

Distribution valves differ by:

- control method (pneumatic, mechanical, electromagnetic),
- method of supplying the medium to the controller,
- number of medium flow paths,
- valve size.

Depending on the number of medium flow paths, the valves are divided as follows:

- 2-way
- 3-way
- 4-way
- 5-way

Depending on the number of stable positions of the flow control element, the valves are divided as follows:

- 2-position
- 3-position; paths 2 and 4 in the middle position may be:
  - cut off,
  - connected to the atmosphere,
  - connected to the supply.

**Compressed air preparation units** – are used to remove solid and liquid contaminants from the working medium, set and maintain a constant medium pressure and saturate compressed air with oil mist in order to ensure correct operation of actuating and control elements. The correct preparation of compressed air has a huge impact on the reliability of pneumatic systems and components. CPP "PREMA" S.A. manufactures elements of the air preparation units with connection sizes from G1/4 to G3/4.

In 1 m<sup>3</sup> of compressed air, there is a series of impurities. In order for the air to be suitable for use in pneumatic systems, it requires preparation, including:

- filtration,
- oil removal,
- drying of the working medium,
- control of the working medium pressure,
- lubrication.

Properties of the prepared and purified compressed air:

- no oil in the form of droplets,
- no water in the form of droplets,
- mechanical impurities with particle size below 40  $\mu\text{m}$ .

### Concentration of solid contaminants:

Class	Largest particle size <sup>1)</sup> $\mu\text{m}$	Maximum mass concentration $\text{mg}/\text{m}^3$	
3	5	5	<sup>1)</sup> The particle size refers to the filtration factor $B_N=20$ . The minimum accuracy of the measurement method used shall be equal to 20% of the limit value for the class.
4	10	8	
5	40	10	<sup>2)</sup> At 1 bar absolute pressure, +20°C temperature and 0.6 water vapour relative pressure. It is recommended to note that at pressures higher than atmospheric, the concentration of pollutants is correspondingly higher. Specify the measurement method used.

### Calculation of the effective force:

The theoretical pushing or pulling force of a double acting cylinder is calculated from the formula:

$$F = S \cdot p$$

where:

**F** – useful force [daN]

**p** – air pressure [bar]

**S** – active surface area of the piston, i.e. [ $\text{cm}^2$ ]

$$S = \frac{1}{4} \cdot \pi \cdot D^2$$

- to calculate the pushing force

$$S = \frac{1}{4} \cdot \pi \cdot (D^2 - d^2)$$

- to calculate the pulling force

D – piston diameter [cm]

d – piston rod diameter [cm]

Actual force at the piston rod of the cylinder depends on the pressure changes during filling and emptying of the cylinder chambers and changes in the friction force at the seals. In practice, it is beneficial to use the coefficient  $\eta$  which expresses the ratio of useful force  $F_u$  to theoretical force. The following table sets out the recommended values of the coefficient  $\eta$ .

Mode of operation	Coefficient values $\eta$
Slow movement, end of stroke load	<b>0.8</b>
Fast movement, end of stroke load or slow movement, full stroke load	<b>0.75</b>
Fast movement, approximate full stroke load	<b>0.65</b>

### Calculation of air requirement:

Approximate air requirements (reduced to normal conditions) during  $n$  full strokes of the cylinder is calculated according to the formula:

$$V = \frac{1}{4} \cdot \pi \cdot (2 \cdot D^2 - d^2) \cdot s \cdot n \cdot \left( \frac{p_r}{p_a} + 1 \right) + V_1 \quad [\text{cm}^3]$$

where:

$V$  – air requirement [cm<sup>3</sup>]

$D, d, s$  – diameter of piston, piston rod and stroke of cylinder [cm],

$n$  – number of full strokes of the cylinder,

$p_r, p_a$  – working pressure (overpressure) and atmospheric pressure [bar],

$V_1$  – clearance volume (e.g. volume of supply lines) [cm<sup>3</sup>].

## Theoretical pushing force on the piston rod of double acting cylinders with single-sided piston rod

Theoretical pushing force [daN][kG]								
Cylinder diameter	Air pressure [MPa]							
	0.3	0.4	0.5	0.6	0.7	0.8	0.9	1.0
<b>D12</b>	3.9	4.52	5.65	6.79	7.92	9.05	10.18	11.31
<b>D16</b>	6.03	8.04	10.05	12.06	14.07	16.09	18.10	20.11
<b>D20</b>	9.42	12.56	15.7	18.85	21.99	25.13	28.27	31.42
<b>D25</b>	14.72	19.63	24.54	29.42	34.36	39.27	44.17	49.09
<b>D32</b>	24.12	32.17	40.21	48.25	56.29	64.34	72.38	80.42
<b>D40</b>	37.7	50.2	62.8	75.4	88	100.5	113	125.7
<b>D50</b>	59	78.5	98	117	137	157	176	196
<b>D63</b>	93.5	124	155	187	218	249	280	311
<b>D80</b>	150	201	251	301	351	402	452	502
<b>D100</b>	235	314	392	471	549	628	706	785
<b>D125</b>	368	490	613	736	859	981	1104	1227
<b>D160</b>	603	804	1005	1206	1407	1608	1810	2011
<b>D200</b>	942	1257	1571	1885	2199	2513	2827	3142
<b>D250</b>	1473	1963	2454	2945	3436	3927	4418	4909
<b>D320</b>	2492	3322	4153	4984	5814	6645	7476	8306

**Approximate air requirement for one working cycle of a double-acting cylinder  
with single-sided piston rod**

<b>Approximate air requirement at 0.63 MPa [normal dm<sup>3</sup>]</b>		
<b>Cylinder diameter</b>	<b>Requirement for 100 mm stroke</b>	<b>Increase in requirement for each additional 100 mm</b>
<b>D12</b>	0.165	0.144
<b>D16</b>	0.293	0.272
<b>D20</b>	0.459	0.401
<b>D25</b>	0.716	0.659
<b>D32</b>	1.174	1.117
<b>D40</b>	1.835	1.649
<b>D50</b>	2.867	2.681
<b>D63</b>	4.551	4.274
<b>D80</b>	7.339	7.061
<b>D100</b>	11.47	10.88
<b>D125</b>	17.92	17.33
<b>D160</b>	29.36	28.44
<b>D200</b>	45.87	44.95
<b>D250</b>	71.67	70.23

# TABLE OF CONTENTS

---

PNEUMATIC CYLINDERS	01
---------------------	----

---

HYDRAULIC CYLINDERS	02
---------------------	----

---

ROTARY ACTUATORS	03
------------------	----

---

DISTRIBUTION VALVES	04
---------------------	----

---

VALVE TERMINALS	05
-----------------	----

---

FLOW, CUT-OFF AND LOGIC VALVES	06
--------------------------------	----

---

VALVES FOR VARIOUS WORKING MEDIA	07
----------------------------------	----

---

OFFER FOR MINING AND RAILWAY INDUSTRIES	08
---	----

---

COMPRESSED AIR PREPARATION UNITS	09
----------------------------------	----

---

FITTINGS AND ACCESSORIES	10
--------------------------	----

---



















# PNEUMATIC CYLINDERS

## Pneumatic cylinders

- 1.01.** SMI series mini-cylinders
- 1.02.** STD series mini-cylinders
- 1.03.** SOK series round cylinders
- 1.04.** SSI series cylinders according to ISO 15552(6431) standard
- 1.05.** STK series cylinders with shaped tubes
- 1.06.** STE series cylinders with profile tubes
- 1.07.** SCN series cylinders according to CNOMO standard
- 1.08.** SDK series pressure cylinders
- 1.09.** SKP series compact cylinders
- 1.10.** SCP series Cliper mini-cylinders
- 1.11.** SPT series double rod cylinders
- 1.12.** SWH series rotary cylinders
- 1.13.** SPS series food industry cylinders
- 1.14.** Rodless cylinders
- 1.15.** Special cylinders
- 1.16.** CPKB series angle grippers
- 1.17.** Accessories for cylinders
  - 1.17.01.** Mounting elements
  - 1.17.02.** Guides for mini-cylinders D12–D32
  - 1.17.03.** Guides for cylinders according to ISO standard
  - 1.17.04.** Piston rod lock
  - 1.17.05.** Piston rod covers
  - 1.17.06.** Magnetic field sensors
- 1.18.** Repair kits

	<b>SMI series</b>	SMI series Mini-cylinders according to ISO 6432	<b>D12 – D25</b>	page 1.01.01
	<b>STD series</b>	STD series Mini-cylinders	<b>D32</b>	page 1.02.01
	<b>SOK series</b>	SOK series Round cylinders	<b>D32 – D100</b>	page 1.03.01
	<b>SSI series</b>	SSI series cylinders according to ISO 15552 and VDMA 24562 standard	<b>D32 – D320</b>	page 1.04.01
	<b>STK series</b>	STK series Cylinders with shaped tubes according to ISO 15552 and VDMA 24562	<b>D32 – D100</b>	page 1.05.01
	<b>STE series</b>	STE series Cylinders with profile tubes according to ISO 15552	<b>D32 – D100</b>	page 1.06.01
	<b>SCN series</b>	SCN series cylinders according to CNOMO standard	<b>D32 – D200</b>	page 1.07.01
	<b>SDK series</b>	SDK series Pressure cylinders	<b>D16 – D100</b>	page 1.08.01
	<b>SKP series</b>	SKP series Compact cylinders according to ISO 21287	<b>D16 – D100</b>	page 1.09.01
	<b>SCP series</b>	SCP series Mini-cylinders	<b>D25 – D32</b>	page 1.10.01
	<b>SPT series</b>	SPT series Double rod cylinders	<b>D32 – D100</b>	page 1.11.01
	<b>SWH series</b>	SWH series Rotary cylinders	<b>D32 – D125</b>	page 1.12.01
	<b>SPS series</b>	SPS series Food industry cylinders	<b>D63 – D100</b>	page 1.13.01























































































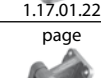

# MOUNTING ELEMENTS

for pneumatic cylinders

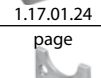
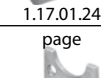
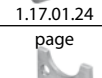
list

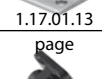

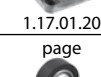
1

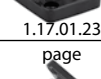
							
<b>SMI series</b>	<b>STD series</b>	<b>SSI series</b>	<b>STK series</b>	<b>STE series</b>	<b>SCN series</b>	<b>SKP series</b>	<b>SPT series</b>
page  1.17.01.11	page  1.17.01.12	page  1.17.01.11	page  1.17.01.11	page  1.17.01.11	page  1.17.01.11	page  1.17.01.11	page  1.17.01.11
page  1.17.01.21	page  1.17.01.13	page  1.17.01.11	page  1.17.01.11	page  1.17.01.11	page  1.17.01.11	page  1.17.01.11	page  1.17.01.19
page  1.17.01.15	page  1.17.01.21	page  1.17.01.19	page  1.17.01.19	page  1.17.01.19	page  1.17.01.19	page  1.17.01.13	page  1.17.01.14
page  1.17.01.12	page  1.17.01.16	page  1.17.01.19	page  1.17.01.19	page  1.17.01.19	page  1.17.01.19	page  1.17.01.20	page  1.17.01.24
page  1.17.01.13	page  1.17.01.15	page  1.17.01.20	page  1.17.01.20	page  1.17.01.20	page  1.17.01.11	page  1.17.01.22	page  1.17.01.18
page  1.17.01.15		page  1.17.01.14	page  1.17.01.14	page  1.17.01.14	page  1.17.01.15	page  1.17.01.24	page  1.17.01.22
		page  1.17.01.16	page  1.17.01.16	page  1.17.01.16	page  1.17.01.23	page  1.17.01.16	page  1.17.01.16
		page  1.17.01.12	page  1.17.01.12	page  1.17.01.12	page  1.17.01.12	page  1.17.01.12	page  1.17.01.13
		page  1.17.01.17	page  1.17.01.18	page  1.17.01.18	page  1.17.01.17	page  1.17.01.22	page  1.17.01.22
		page  1.17.01.22	page  1.17.01.22	page  1.17.01.22	page  1.17.01.14	page  1.17.01.23	page  1.17.01.23
		page  1.17.01.24	page  1.17.01.24	page  1.17.01.24			
		page  1.17.01.13	page  1.17.01.13	page  1.17.01.13			
		page  1.17.01.22	page  1.17.01.20	page  1.17.01.22			
		page  1.17.01.23	page  1.17.01.23	page  1.17.01.23			
			page  1.17.01.22				

### TECHNICAL SPECIFICATIONS

<b>Maximum operating pressure:</b>	10 bar	
<b>Medium:</b>	compressed air, filtered, lubricated or non-lubricated	
<b>Construction materials:</b>		
<b>Covers, piston</b>	- aluminium alloy	
<b>Piston rod</b>	- chrome-plated carbon steel, acid-resistant steel	
<b>Tube</b>	- aluminium alloy	
<b>Sealing</b>	- polyurethane (working temperature from -20 to +80°C) - NBR nitrile-butadiene rubber (working temp. -20 to +90°C) for the variety 005, 006	
<b>Diameters:</b>	D12-D25	
<b>Standard stroke range:</b>	5-300 mm*	

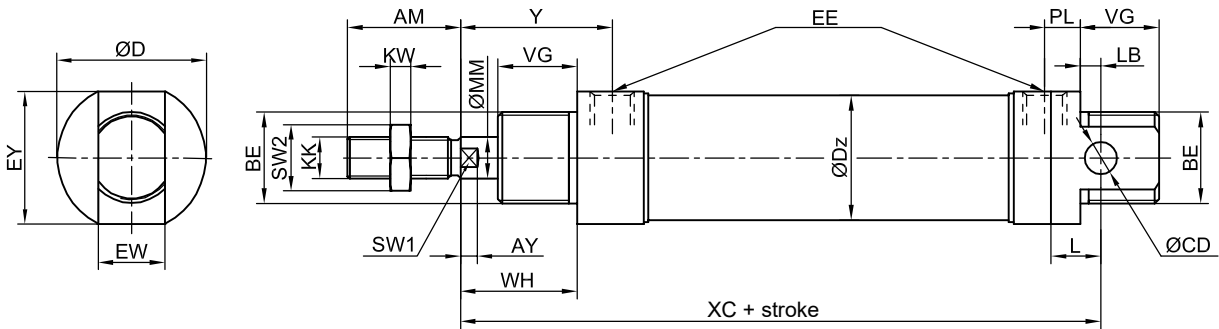

Cylinder diameter [mm]	Dimension [mm]																				Weight [kg]***		
	AM	AY	BE	ØCD H9	ØD	ØDz	EE	EW d13	EY	KK	KW	L	LB**	ØMM**	PL**	SW1**	SW2	VG	WH	XC	Y	1	2
12	16	3	M16×1.5	6	22	16	M5	12	19	M6	3	9	3	6	5.5	5	10	15	22	75	27.5	0.048	0.0045
16	16	3	M16×1.5	6	25	20	M5	12	23	M6	3	9	5	6	5.5	5	10	15	22	82	27.5	0.054	0.0050
20	20	3	M22×1.5	8	30	25	G1/8	16	27	M8	4	12	4	10	8	9	13	18	24	95	32	0.080	0.0100
25	22	4	M22×1.5	8	36	30	G1/8	16	32	M10×1.25	5	12	5	10	8.5	9	16	19	28	104	36.5	0.100	0.0140

\* Other stroke lengths manufactured after prior technical consultation.

\*\* " For variation 026 with diameter D20, the dimension: LB=7; ØMM=8; PL=7.5; SW1=7.

\*\*\* For cylinders with a single-sided piston rod and aluminium tube (1) Cylinder weight with 0 mm stroke (2) Weight increase for every additional 10 mm stroke.

# SMI SERIES

## Mini-cylinders

according to ISO 6432



### ORDER NUMBER CONSTRUCTION

**11 . 005D . 0100**

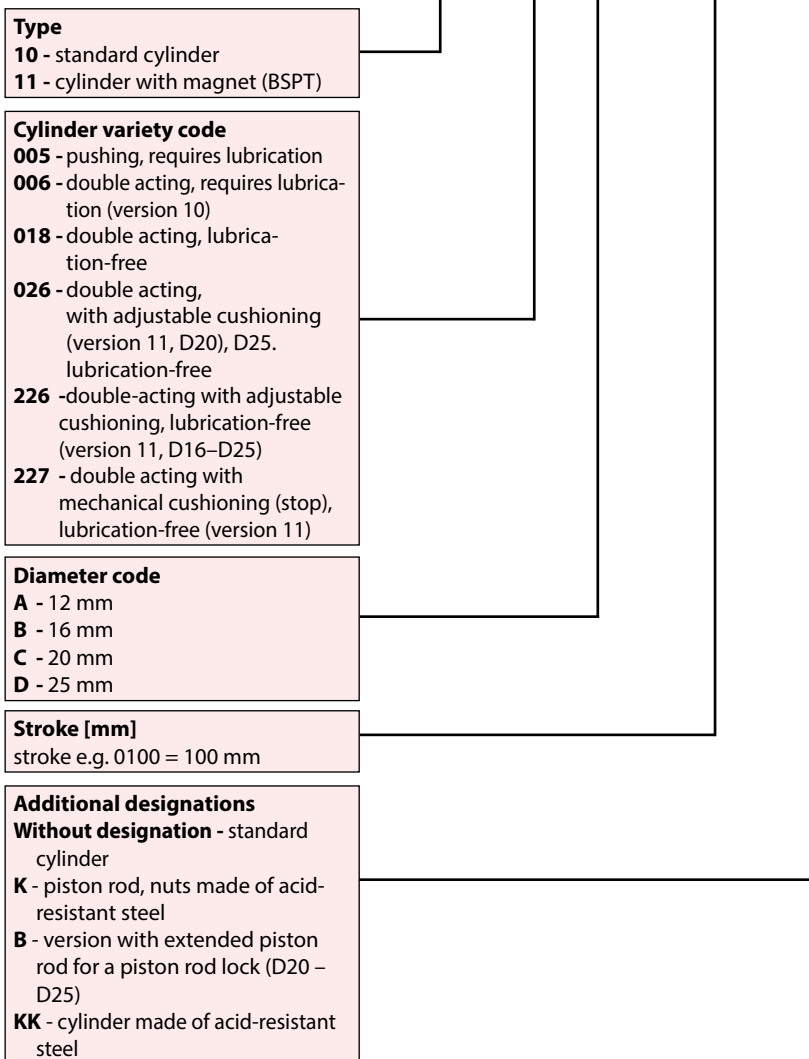

### ORDERING PROCEDURE

The order should include: name, nominal diameter, cylinder stroke, order number and the number of pieces, e.g.:

**Mini cylinder SMI D25 x 100 no. 11.005D.0100 1 pc.**

### ADDITIONAL ELEMENTS

Mounting elements for SMI series cylinders	page 1.17.01.01
Repair kits for SMI series cylinders	page 1.18.01-03

### TECHNICAL SPECIFICATIONS

<b>Maximum operating pressure:</b>	10 bar	
<b>Medium:</b>	compressed air, filtered, lubricated or non-lubricated	
<b>Construction materials:</b>		
<b>Covers, piston</b>	- aluminium alloy	
<b>Piston rod</b>	- chrome-plated carbon steel, acid-resistant steel	
<b>Tube</b>	- aluminium alloy*	
<b>Sealing</b>	- NBR nitrile-butadiene rubber (working temp. from -20 to +90°C) - polyurethane (working temperature from -20 to +80°C) for variety 019	
<b>Diameter:</b>	D32	
<b>Standard stroke range:</b>	5-400mm* 5-80mm* pushing, pulling	

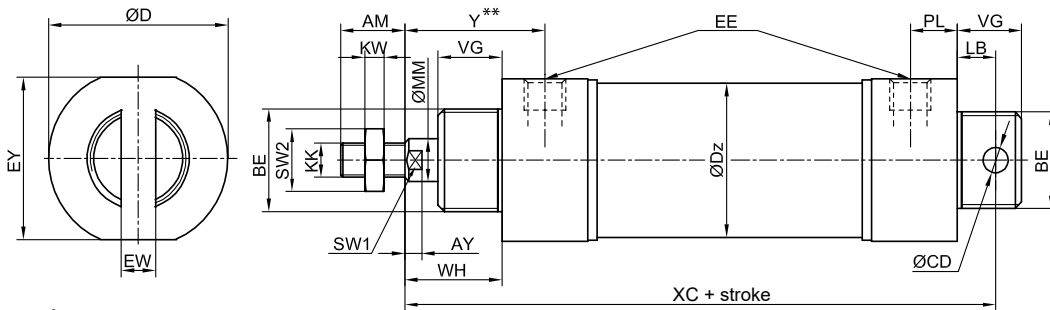

Cylinder variants 008, 009, 010

Cylinder diameter [mm]	Dimension [mm]																	Weight [kg]***		
	AM	AY	BE	ØCD H10	ØD	ØDz	EE	EW d13	EY	KK	KW	LB	ØMM	PL	SW1	SW2	VG	Y**	1	2
32	15	4	M24x1.5	6	42	36	G1/8	8	38	M8x1	4	9	10	11	9	13	15	33	0.280	0.015

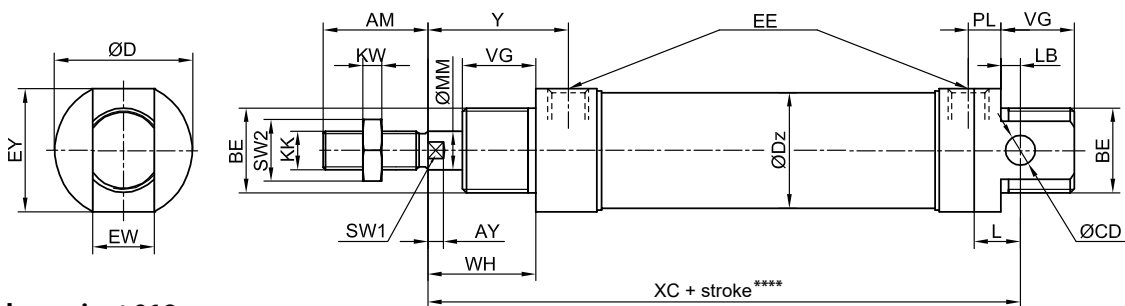

Cylinder variant 019

Cylinder diameter [mm]	Dimension [mm]																	Weight [kg]***			
	AM	AY	BE	ØCD H9	ØD	ØDz	EE	EW d13	EY	KK	KW	L	LB	ØMM	PL	SW1	SW2	VG	Y	1	2
32	22	4	M22x1.5	8	42	36	G1/8	16	38	M10x1.25	5	12	5	10	8.5	9	16	19	36.5	0.280	0.015

\* Other versions and stroke lengths manufactured after prior technical consultation.

\*\* For cylinder version 009 Y=33+stroke

\*\*\* For cylinders with a single-sided piston rod and aluminium tube (1) Cylinder weight with 0 mm stroke (2) Weight increase for every additional 10 mm stroke.

\*\*\*\* For pulling cylinders XC + 2 x stroke.



Series	Stroke	XC	WH
008	0-16	127	22
	17-32	139	
	33-48	151	
	49-64	163	
	65-80	175	
009	0-16	127	22+stroke
	17-32	139	
	33-48	151	
	49-64	163	
	65-80	175	
010	0-400	110	22
019	0-400	104	28

### ORDER NUMBER CONSTRUCTION

**11 . 010 E . 0100** \_

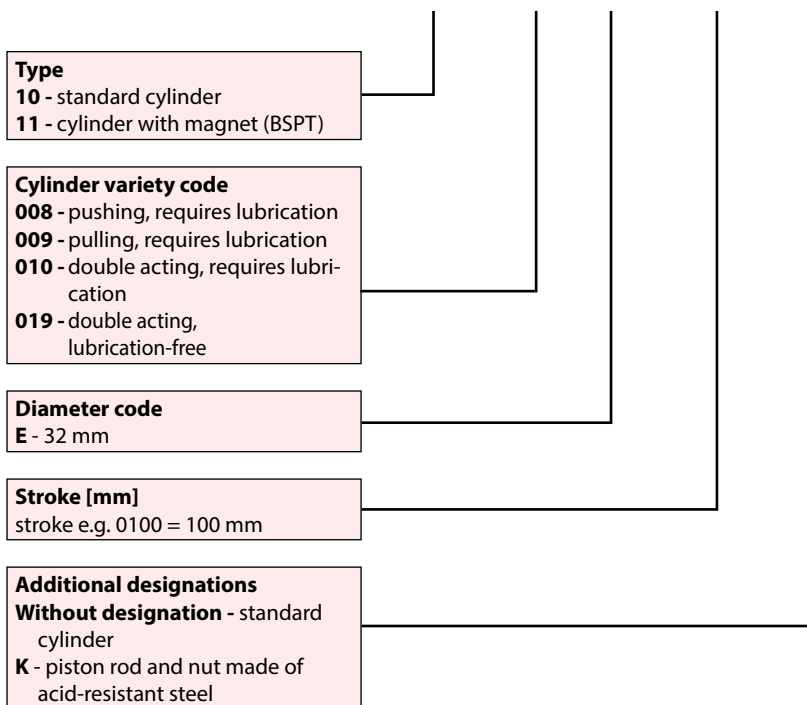

### ORDERING PROCEDURE

The order should include: name, nominal diameter, cylinder stroke, order number and the number of pieces, e.g.:  
**Cylinder STD D32 x 100 no. 11.010E.0100 1 pc.**

### ADDITIONAL ELEMENTS

Mounting elements for STD series cylinders	page 1.17.01.01
Repair kits for STD series cylinders	page 1.18.04-05

### TECHNICAL SPECIFICATIONS

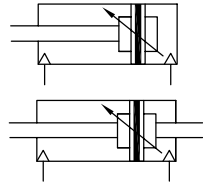
<b>Maximum operating pressure:</b>	10 bar	
<b>Medium:</b>	compressed air, filtered, lubricated or non-lubricated	
<b>Construction materials:</b>		
<b>Covers</b>	- aluminium alloy	
<b>Piston rod</b>	- chrome-plated carbon steel, acid-resistant steel	
<b>Sealing</b>	- polyurethane (working temperature from -20 to +80°C)	
<b>Diameters:</b>	D32–D100	
<b>Standard stroke range:</b>	5–500 mm*	



### D32–D63

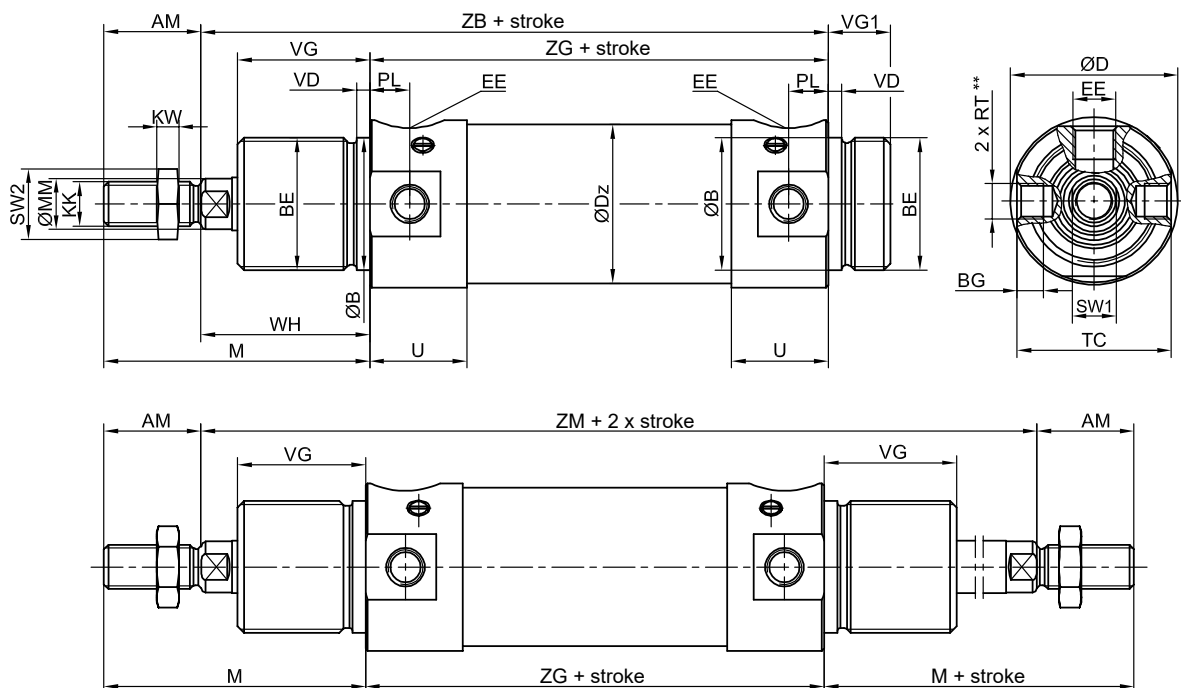

Cylinder diameter [mm]	Dimension [mm]																							
	AM	ØB	BE	BG	ØD	ØDz	EE	KK	KW	M	ØMM	PL	RT	SW1	SW2	TC	U	VD	VG	VG1	WH	ZB	ZG	ZM
32	22	30	M30×1.5	6	38	36	G1/8	M10×1.25	5	60	12	9	M8×1	10	16	35	22	3	30	14	39	133	94	173
40	24	38	M38×1.5	8	46	45	G1/4	M12×1.25	6	69	16	12	M10×1	13	18	44	24	3	35	16	47	152	105	199
50	32	45	M45×1.5	9.5	56	55	G1/4	M16×1.5	8	82	20	12	M12×1.5	16	24	54	24	3	38	18	51	157	106	208
63	32	45	M45×1.5	10	70	68	G3/8	M16×1.5	8	83	20	13	M14×1.5	16	24	67	32	3	38	18	52	173	121	226

\* Other stroke lengths manufactured after prior technical consultation.

\*\* Mounting hole.

# SOK SERIES

## Round cylinders



### D80-D100

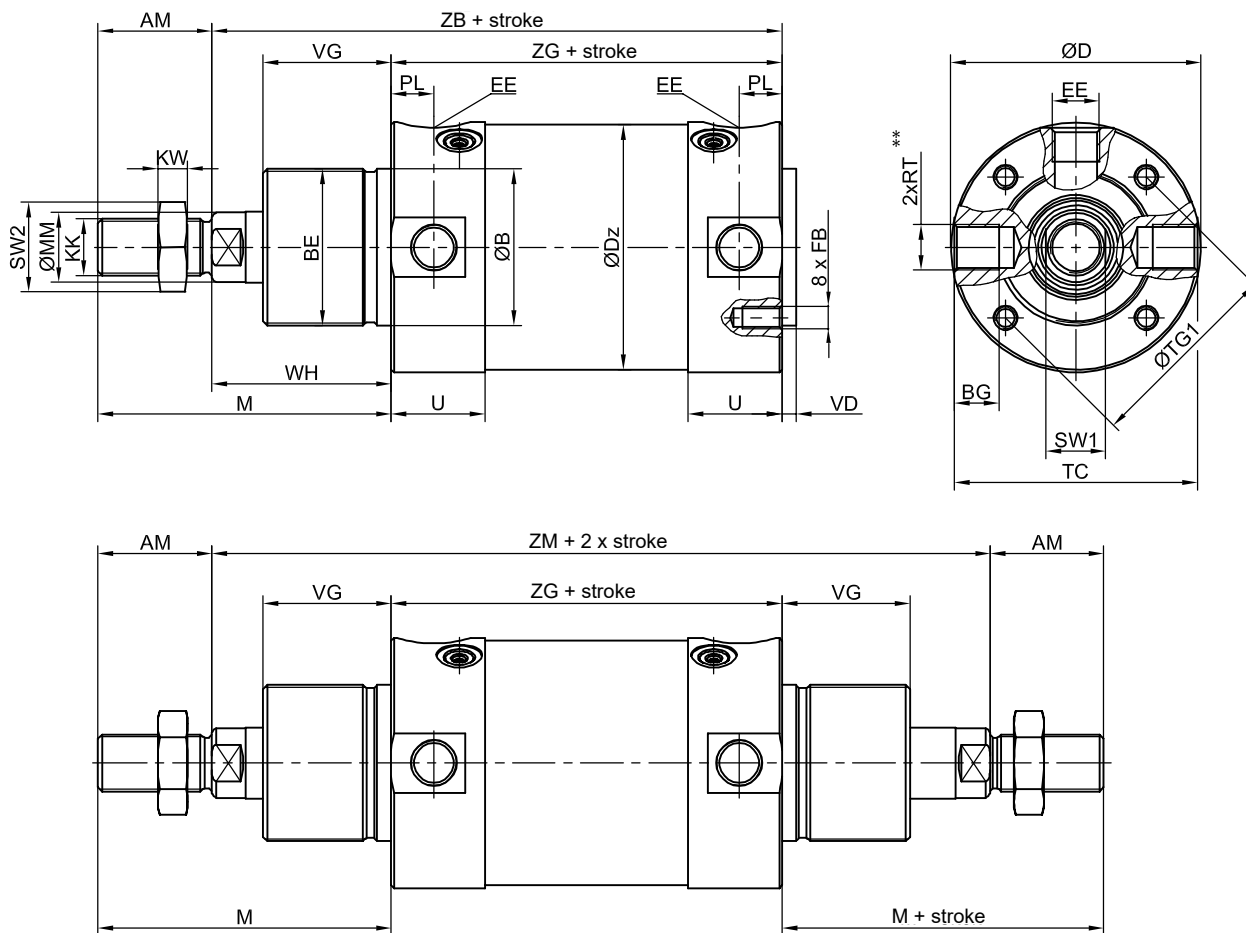

Cylinder diameter [mm]	Dimension [mm]																								
	AM	ØB	BE	BG	ØD	ØDz	EE	FB	KK	KW	M	ØMM	PL	RT	SW1	SW2	TC	ØTG1	U	VD	VG	WH	ZB	ZG	ZM
80	40	55	M55×1.5	17.5	88	86	G3/8	M8	M20×1.5	10	101	25	13	M16×1.5	21	30	85.5	70	33	5	45	63	191	128	254
100	40	55	M55×1.5	21.5	108	106	G1/2	M10	M20×1.5	10	101	25	13	M20×1.5	21	30	105.5	80	35.5	5	45	63	201	138	264

\*\* Mounting hole.

## ORDER NUMBER CONSTRUCTION

**11 . 070H . 0500 A X** \_

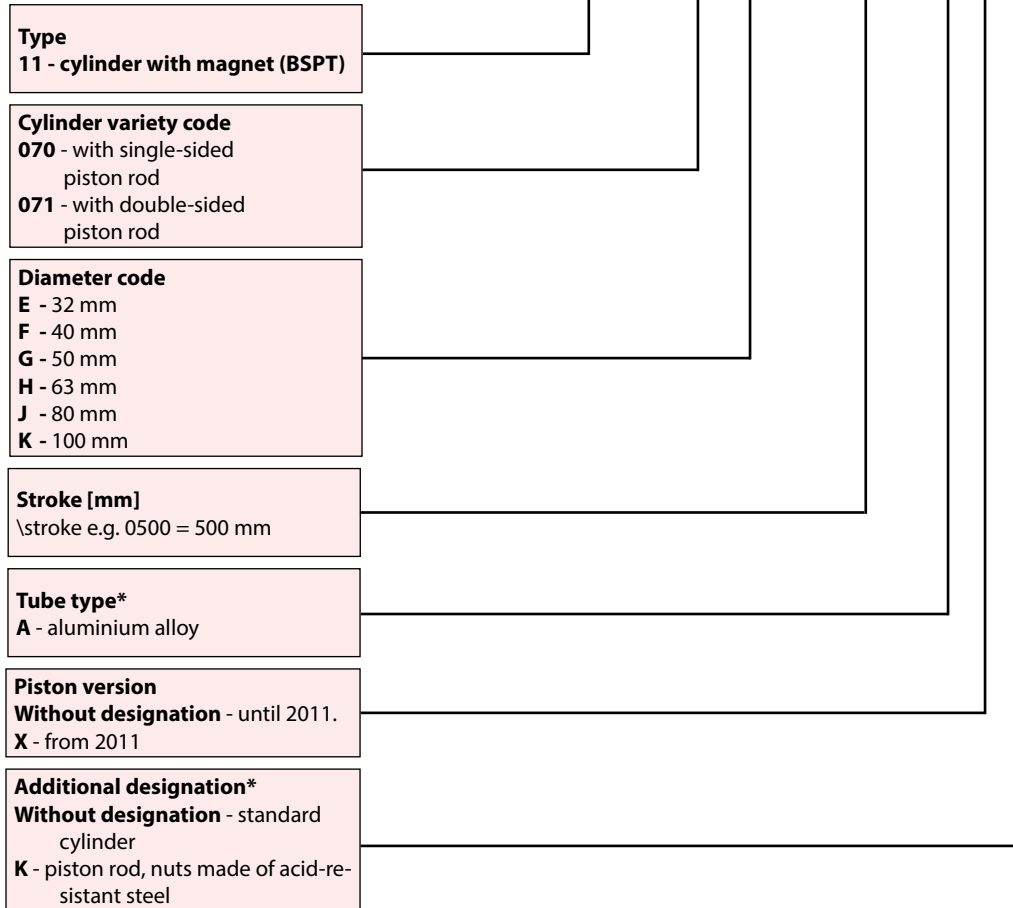

## ORDERING PROCEDURE

The order should include: name, nominal diameter, cylinder stroke, order number and the number of pieces, e.g.:  
**Cylinder SOK D63 x 500 no. 11.070H.0500AX 1 pc.**

## ADDITIONAL ELEMENTS

Repair kits for SOK series cylinders	page 1.18.06
--------------------------------------	--------------

\* Other versions after technical consultation



### TECHNICAL SPECIFICATIONS

<b>Maximum operating pressure:</b>	10 bar	
<b>Medium:</b>	compressed air, filtered, lubricated or non-lubricated	
<b>Construction materials:</b>		
<b>Covers, piston</b>	- aluminium alloy	
<b>Piston rod</b>	- chrome-plated carbon steel, acid-resistant steel	
<b>Tube</b>	- aluminium alloy, chrome-plated carbon steel, carbon steel	
<b>Sealing</b>	- polyurethane (working temperature from -20 to +80°C) - viton (working temperature from -20 to +150°C)	
<b>Scraper</b>	- NBR (operating temperature from -20 to +90°C) - viton (working temperature from -20 to +150°C)	
<b>Diameters:</b>	D32–D320	
<b>Standard stroke range:</b>	5–500 mm*	

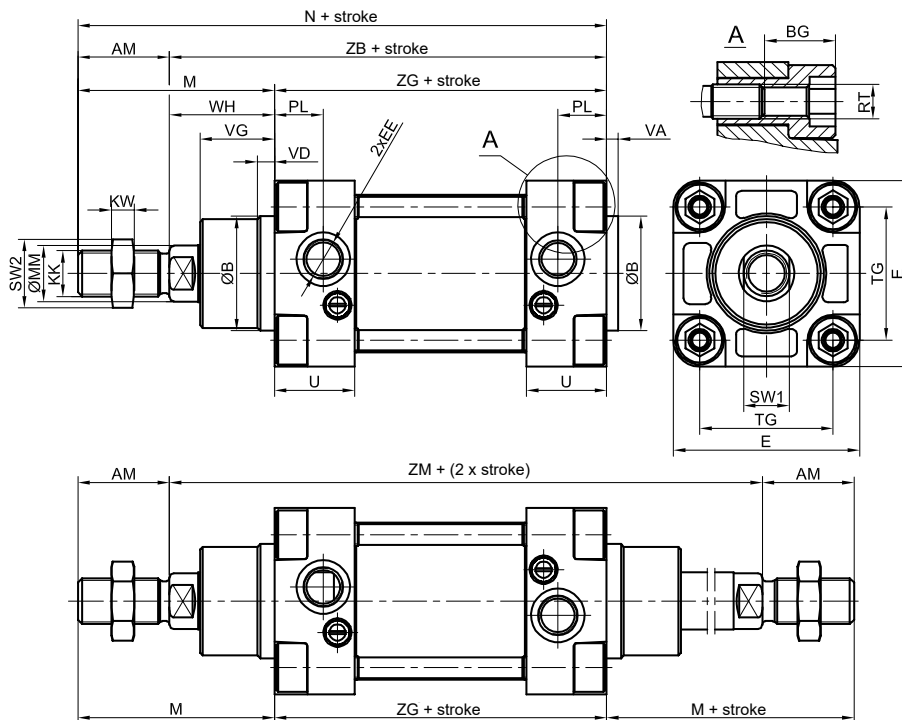

Cylinder diameter [mm]	Dimension [mm]																				Weight [kg]**				
	AM	ØB d11	BG	E	EE	KK	KW	M	ØMM f8	N	PL	RT	SW1	SW2	TG	U	VA	VD	VG	WH	ZB	ZG	ZM	1	2
32	22	30	14	46.5	G1/8	M10x1.25	5	48	12	142	17	M6	16	10	32.5	26.5	4	6	18	26	120	94	146	0.575	0.0245
40	24	35	16	52	G1/4	M12x1.25	6	54	16	159	17	M6	18	13	38	29	4	6	22	30	135	105	165	0.821	0.0309
50	32	40	16	65	G1/4	M16x1.5	8	69	20	175	17	M8	24	16	46.5	28	4	6	26	37	143	106	180	1.234	0.0486
63	32	45	18	75	G3/8	M16x1.5	8	69	20	190	20	M8	24	16	56.5	33	4	6	26	37	158	121	195	1.807	0.0543
80	40	45	18	95	G3/8	M20x1.5	10	86	25	214	20	M10	30	21	72	33.5	4	6	32	46	174	128	220	2.864	0.0796
100	40	55	20	113	G1/2	M20x1.5	10	91	25	229	20	M10	30	21	89	38	4	6	36	51	189	138	240	4.143	0.0938
125	54	60	25	140	G1/2	M27x2	13.5	119	32	279	33	M12	41	27	110	49	6	8	40	65	225	160	290	7.12	0.21
160	72	65	28	180	G3/4	M36x2	18	152	40	332	30	M16	55	36	140	50	6	8	50	80	260	180	340	14.5	0.35
200	72	75	28	220	G3/4	M36x2	18	167	40	347	30	M16	55	36	175	50	6	8	55	95	275	180	370	22.5	0.41
250	84	90	32	270	G1	M42x2	21	189	50	389	31	M20	65	46	220	56.5	10	10	76	105	305	200	410	38.1	0.31
320	96	110	35	340	G1	M48x2	24	216	63	436	35	M24	75	55	270	58	10	12	80	120	340	220	460	43.2	0.5

\* Other stroke lengths manufactured after prior technical consultation.

\*\* For cylinders with a single-sided piston rod and aluminium tube (1) Cylinder weight with 0 mm stroke (2) Weight increase for every additional 10 mm stroke.

### TECHNICAL SPECIFICATIONS

<b>Maximum operating pressure:</b>	10 bar	
<b>Medium:</b>	compressed air, filtered, lubricated or non-lubricated	
<b>Construction materials:</b>		
<b>Covers, piston</b>	- aluminium alloy	
<b>Piston rod</b>	- chrome-plated carbon steel, acid-resistant steel	
<b>Tube</b>	- aluminium alloy, chrome-plated carbon steel, carbon steel, acid-resistant steel	
<b>Sealing</b>	- polyurethane (working temperature from -20 to +80°C) - viton (working temperature from -20 to +150°C)	
<b>Diameters:</b>	D32–D320	
<b>Standard stroke range:</b>	5–500 mm*	

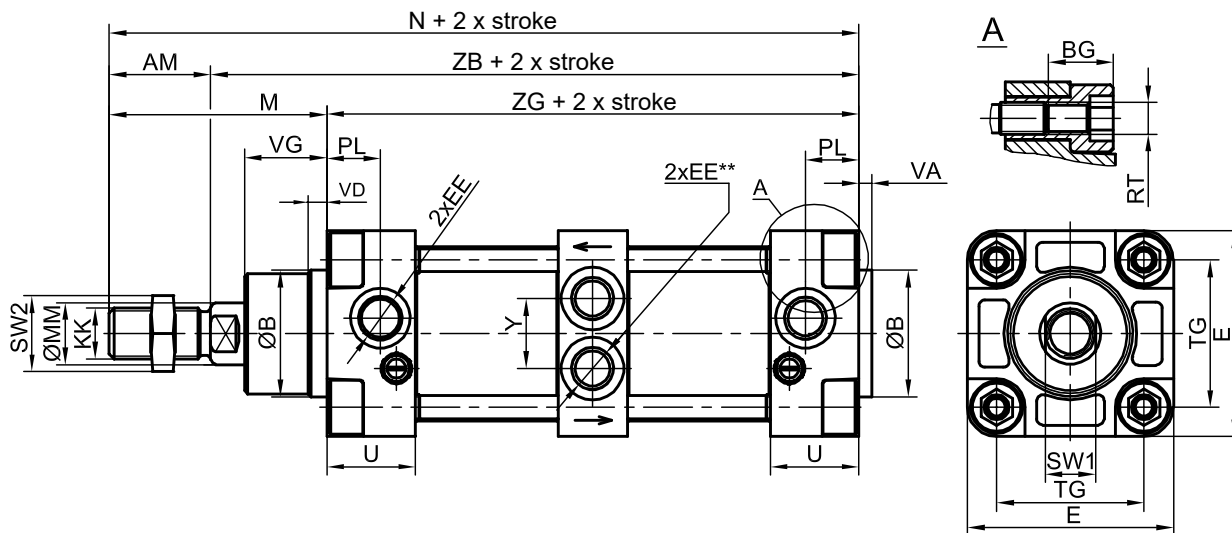

Cylinder diameter [mm]	Dimension [mm]																						
	AM	ØB d11	BG	E	EE	KK	SW1	KW	M	ØMM f8	N	PL	RT	SW2	TG	U	VA	VD	VG	WH	ZB	ZG	Y
32	22	30	14	46.5	G1/8	M10×1.25	16	5	48	12	153	17	M6	10	32.5	26.5	4	6	18	26	179	153	16
40	24	35	17	52	G1/4	M12×1.25	18	6	54	16	228	17	M6	13	38	29	4	6	22	30	204	174	18
50	32	40	17	65	G1/4	M16×1.5	24	8	69	20	247	17	M8	16	46.5	28	4	6	26	37	215	178	22
63	32	45	21.5	75	G3/8	M16×1.5	24	8	69	20	270	20	M8	16	56.5	33	4	6	26	37	238	201	25
80	40	45	20	95	G3/8	M20×1.5	30	10	86	25	300	20	M10	21	72	33.5	4	6	32	46	260	214	25
100	40	55	24	113	G1/2	M20×1.5	30	10	91	25	323	20	M10	21	89	38	4	6	36	51	283	232	32
125	54	60	31	140	G1/2	M27×2	41	13.5	119	32	373	33	M12	27	110	49	6	8	40	65	319	254	35
160	72	65	28	180	G3/4	M36×2	55	18	152	40	448	30	M16	36	140	50	6	8	50	80	376	296	50
200	72	75	28	220	G3/4	M36×2	55	18	167	40	463	30	M16	36	175	50	6	8	55	95	391	296	50
250	84	90	32	270	G1	M42×2	65	21	189	50	522	31	M20	46	220	56.5	10	10	74	105	438	333	50
320	96	110	35	340	G1	M48×2	75	24	216	63	582	35	M24	55	270	58	10	12	80	120	486	366	50

**Note:**The calculation of the operating force of a TANDEM cylinder can be found on page: no. 3

We manufacture multi-chamber cylinders.

\* Other stroke lengths manufactured after prior technical consultation.

\*\* For the diameter D40 G1/8.

### ORDER NUMBER COMPOSITION

**11 . 016 G . 0350 A**

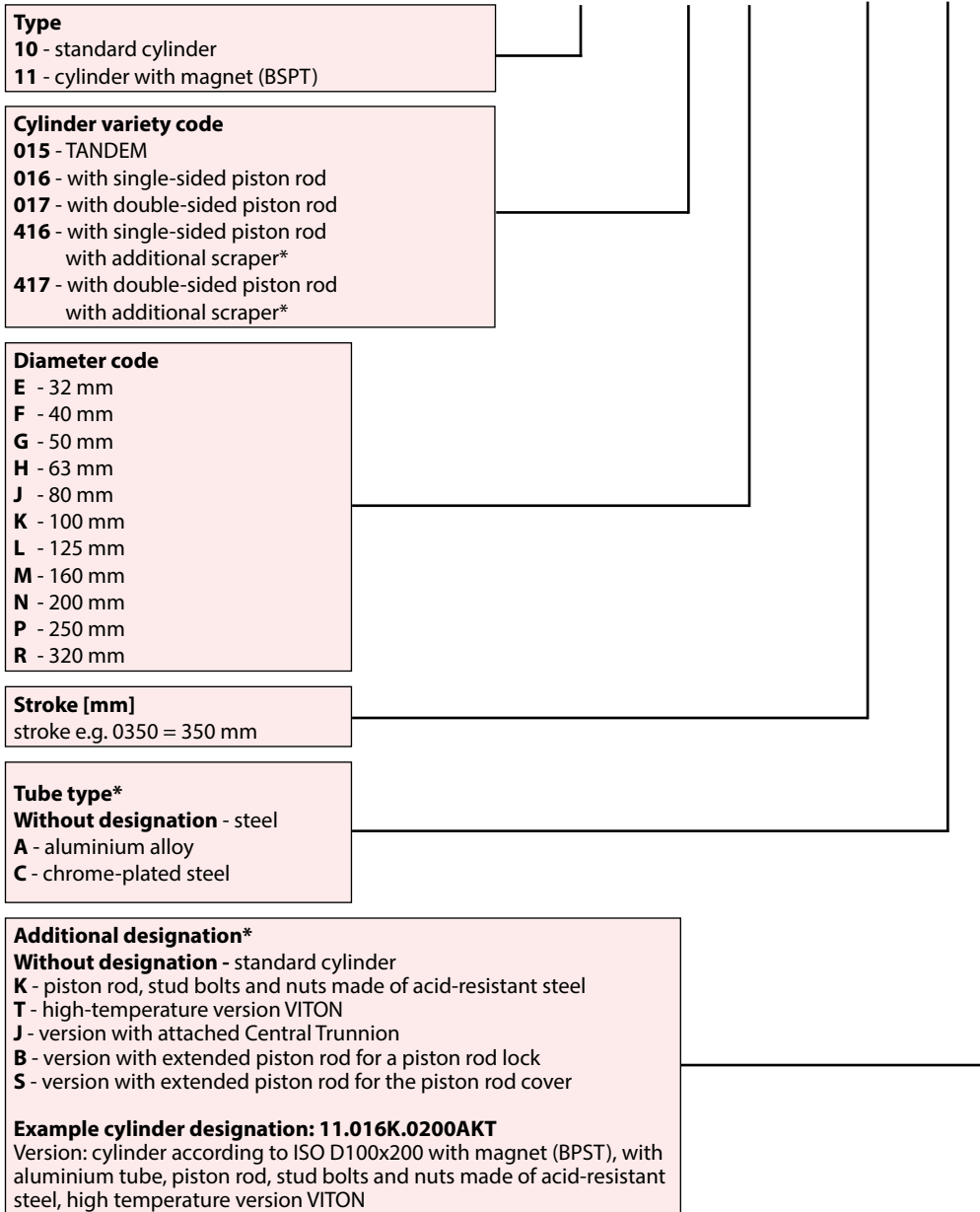

### ORDERING PROCEDURE

The order should include: name, nominal diameter, cylinder stroke, order number and the number of pieces, e.g.:  
**Cylinder SSI D63 x 350 no. 11.016H.0350A 1 pc.**

### ADDITIONAL ELEMENTS

Mounting elements for SSI series cylinders	page 1.17.01.06-07
Repair kits for SSI series cylinders	page 1.18.07-08

\* Other versions after technical consultation





### TECHNICAL SPECIFICATIONS

<b>Maximum operating pressure:</b>	10 bar	
<b>Medium:</b>	compressed air, filtered, lubricated or non-lubricated	
<b>Construction materials:</b>		
<b>Covers, piston</b>	- aluminium alloy	
<b>Piston rod</b>	- chrome-plated carbon steel, acid-resistant steel	
<b>Tube</b>	- aluminium alloy	
<b>Sealing</b>	- polyurethane (working temperature from -20 to +80°C) - viton (working temperature from -20 to +150°C)	
<b>Scraper</b>	- NBR (operating temperature from -20 to +90°C) - viton (working temperature from -20 to +150°C)	
<b>Diameters:</b>	D32-D100	
<b>Standard stroke range:</b>	5-500 mm*	

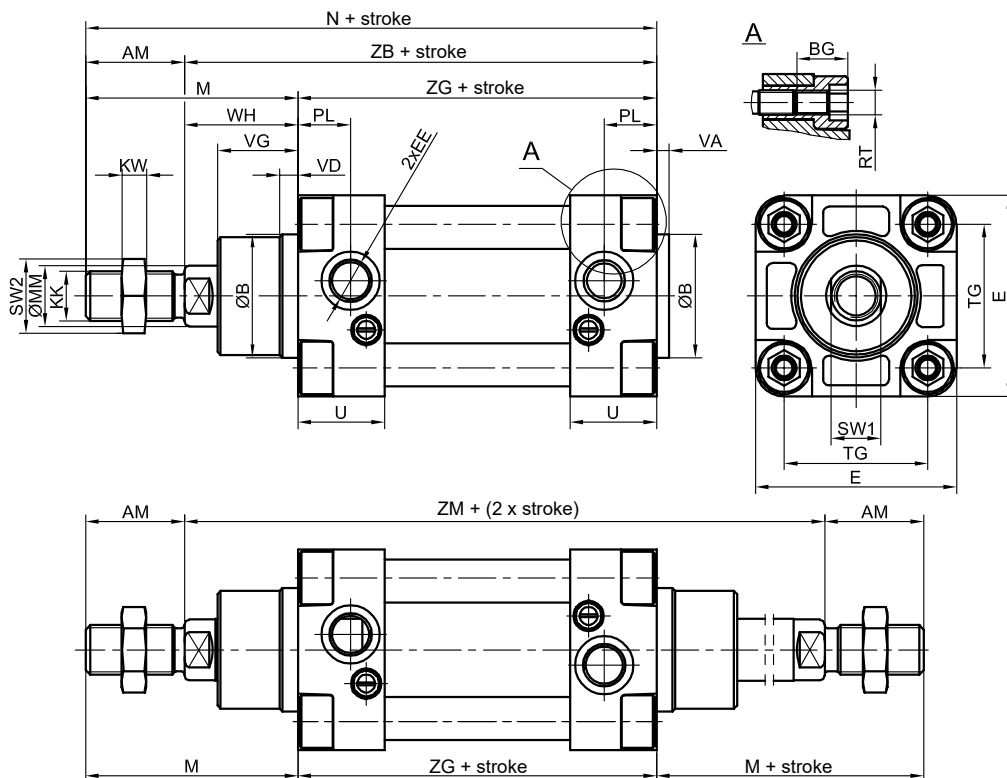

Cylinder diameter [mm]	Dimension [mm]																				Weight [kg]**				
	AM	ØB d11	BG	E	EE	KK	KW	M	ØMM f8	N	PL	RT	SW1	SW2	TG	U	VA	VD	VG	WH	ZB	ZG	ZM	1	2
32	22	30	14	46.5	G1/8	M10x1.25	5	48	12	142	17	M6	10	17	32.5	26.5	4	6	18	26	120	94	146	0.575	0.0245
40	24	35	16	52	G1/4	M12x1.25	6	54	16	159	17	M6	13	19	38	29	4	6	22	30	135	105	165	0.821	0.0309
50	32	40	16	65	G1/4	M16x1.5	8	69	20	175	17	M8	16	24	46.5	28	4	6	26	37	143	106	180	1.234	0.0486
63	32	45	18	75	G3/8	M16x1.5	8	69	20	190	20	M8	16	24	56.5	33	4	6	26	37	158	121	195	1.807	0.0543
80	40	45	18	95	G3/8	M20x1.5	10	86	25	214	20	M10	21	30	72	33.5	4	6	32	46	174	128	220	2.864	0.0796
100	40	55	20	113	G1/2	M20x1.5	10	91	25	229	20	M10	21	30	89	38	4	6	36	51	189	138	240	4.143	0.0938

\* Other stroke lengths manufactured after prior technical consultation.

\*\* For cylinders with a single-sided piston rod and aluminium tube (1) Cylinder weight with 0 mm stroke (2) Weight increase for every additional 10 mm stroke.

# STK SERIES

## Cylinders with shaped tubes

according to ISO 15552 (ISO 6431) and VDMA 24562



### ORDER NUMBER CONSTRUCTION

**11 . 016 E . 0250 P** \_

**Type**  
**10** - standard cylinder  
**11** - cylinder with magnet (BSPT)

**Cylinder variety code**  
**016** - with single-sided piston rod  
**017** - with double-sided piston rod  
**416** - with single-sided piston rod with additional scraper  
**417** - with double-sided piston rod with additional scraper

**Diameter code**  
**E** - 32 mm  
**F** - 40 mm  
**G** - 50 mm  
**H** - 63 mm  
**J** - 80 mm  
**K** - 100 mm

**Stroke [mm]**  
 stroke e.g. 0250 = 250 mm

**Tube type\***  
**P** - aluminium alloy

**Additional designations\***  
**Without designation** - standard cylinder  
**K** - piston rod, stud bolts and nuts made of acid-resistant steel  
**T** - high-temperature version VITON  
**J** - version with attached Central Trunnion  
**B** - version with extended piston rod for a piston rod lock  
**S** - version with extended piston rod for the piston rod cover

**Example cylinder designation: 11.016K.0200PKT**  
 Version: cylinder with shaped tube D100x200 with magnet (BPST), with aluminium tube, piston rod, stud bolts and nuts made of acid-resistant steel, high temperature version VITON

### ORDERING PROCEDURE

The order should include: name, nominal diameter, cylinder stroke, order number and the number of pieces, e.g.:

**Cylinder STK D63 x 250 no. 11.016H.0250P 1 pc.**

### ADDITIONAL ELEMENTS

Mounting elements for STK series cylinders	page 1.17.01.04-05
Repair kits for STK series cylinders	page 1.18.09

\* Other versions after technical consultation.

## TECHNICAL SPECIFICATIONS

<b>Maximum operating pressure:</b>	10 bar
<b>Medium:</b>	compressed air, filtered, lubricated or non-lubricated
<b>Construction materials:</b>	
<b>Covers, piston</b>	- aluminium alloy
<b>Piston rod</b>	- chrome-plated carbon steel, acid-resistant steel
<b>Tube</b>	- aluminium alloy
<b>Sealing</b>	- polyurethane (working temperature from -20 to +80°C)
<b>Diameters:</b>	D32-D100
<b>Standard stroke range:</b>	5-500 mm*

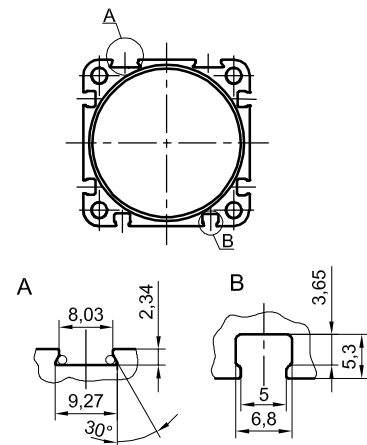
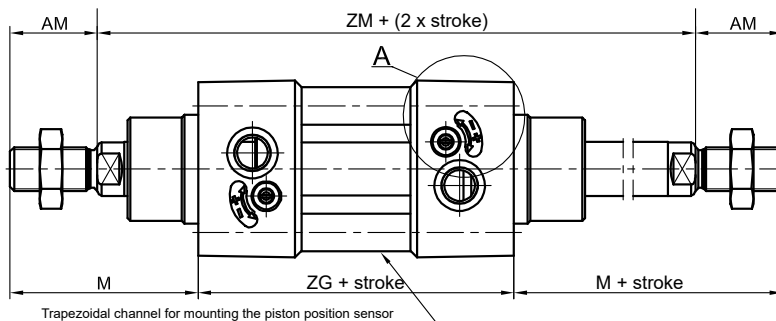
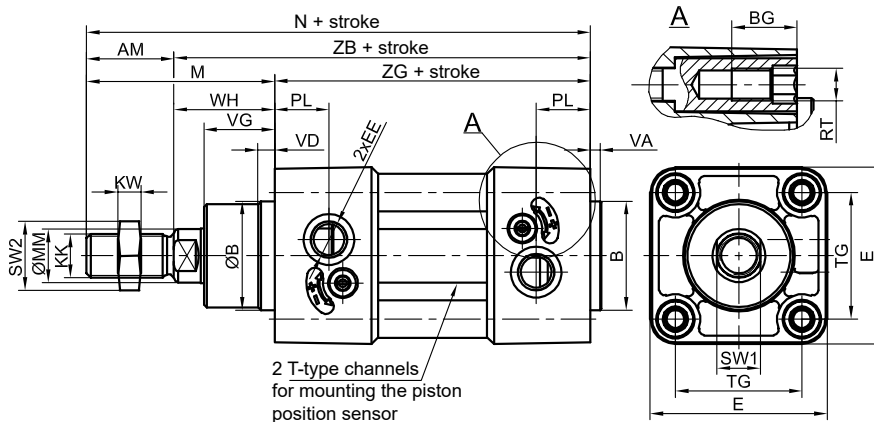
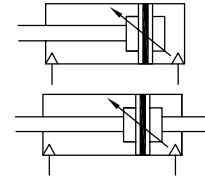

Cylinder diameter [mm]	Dimension [mm]																				Weight [kg]**			
	AM	ØB d11	BG	E	EE	KK	KW	M	ØMM f8	N	PL	RT	SW1	SW2	TG	VA	VD	VG	WH	ZB	ZG	ZM	1	2
32	22	30	14	46.5	G1/8	M10×1.25	5	48	12	142	17	M6	10	17	32.5	4	6	18	26	120	94	146	0.575	0.0245
40	24	35	16	52	G1/4	M12×1.25	6	54	16	159	17	M6	13	19	38	4	6	22	30	135	105	165	0.821	0.0309
50	32	40	16	65	G1/4	M16×1.5	8	69	20	175	17	M8	16	24	46.5	4	6	26	37	143	106	180	1.234	0.0486
63	32	45	18	75	G3/8	M16×1.5	8	69	20	190	20	M8	16	24	56.5	4	6	26	37	158	121	195	1.807	0.0543
80	40	45	18	95	G3/8	M20×1.5	10	86	25	214	25	M10	21	30	72	4	6	32	46	174	128	220	2.927	0.0911
100	40	55	20	113	G1/2	M20×1.5	10	91	25	229	25	M10	21	30	89	4	6	36	51	189	138	240	3.973	0.0944

\* Other stroke lengths manufactured after prior technical consultation.

\*\* For cylinders with a single-sided piston rod and aluminium tube (1) Cylinder weight with 0 mm stroke (2) Weight increase for every additional 10 mm stroke.

# STE SERIES

## Cylinders with profile tubes

according to ISO 15552 (ISO 6431)



### ORDER NUMBER CONSTRUCTION

1

**11 . 116 H . 0500 X**

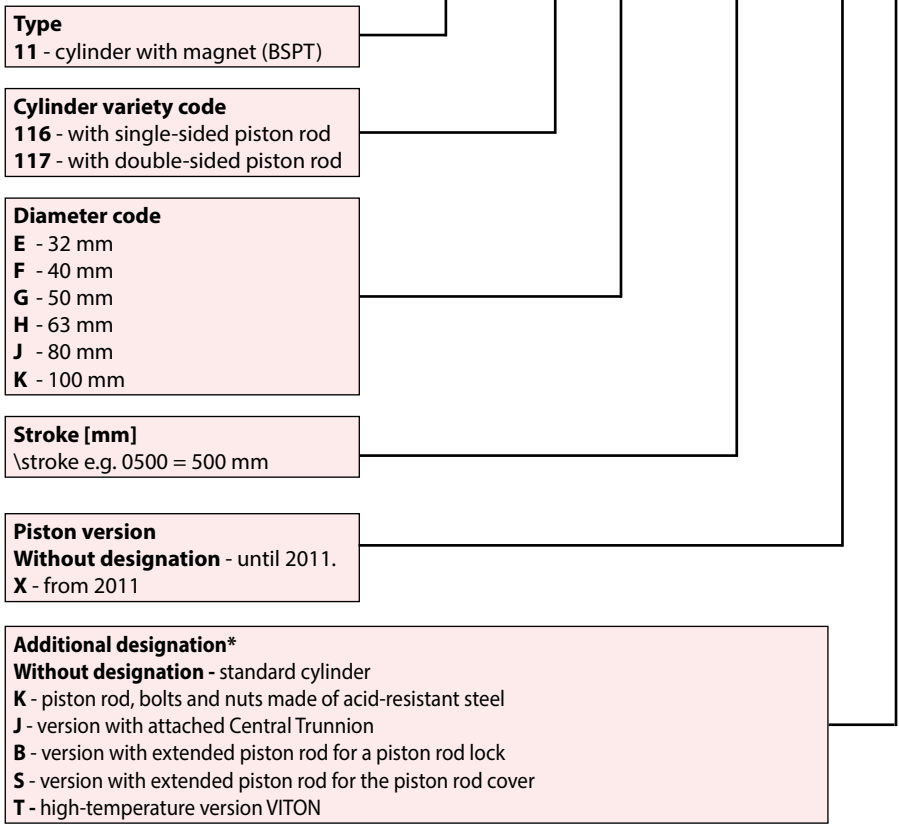

### ORDERING PROCEDURE

The order should include: name, nominal diameter, cylinder stroke, order number and the number of pieces, e.g.:

**Cylinder STE D63 x 500 no. 11.116H.0500 X 1 pc.**

### ADDITIONAL ELEMENTS

Mounting elements for STE series cylinders	page 1.17.01.08-09
Repair kits for STE series cylinders	page 1.18.10

\*Other versions after technical consultation

### TECHNICAL SPECIFICATIONS

<b>Maximum operating pressure:</b>	10 bar	
<b>Medium:</b>	compressed air, filtered, lubricated or non-lubricated	
<b>Construction materials:</b>		
<b>Covers, piston</b>	- aluminium alloy	
<b>Piston rod</b>	- chrome-plated carbon steel, acid-resistant steel	
<b>Tube</b>	- aluminium alloy, chrome-plated carbon steel, carbon steel	
<b>Sealing</b>	- polyurethane (working temperature from -20 to +80°C) - viton (working temperature from -20 to +150°C)	
<b>Diameters:</b>	D32-D200	
<b>Standard stroke range:</b>	5-500 mm*	

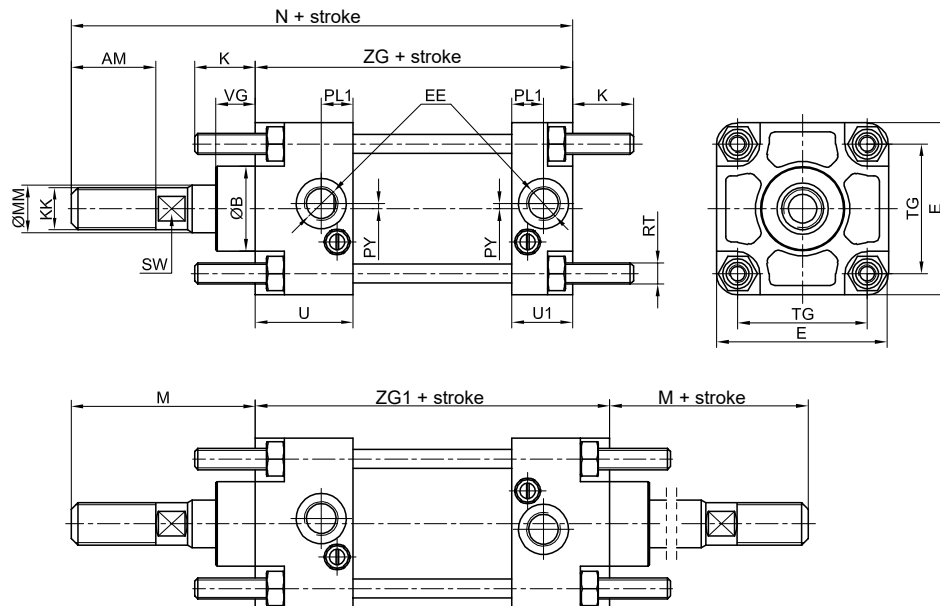

Cylinder diameter [mm]	Dimension [mm]																		Weight [kg]**		
	AM	ØB e9	E	EE	K	KK	M	ØMM f8	N	PL1	PY	RT	SW	TG	U	U1	VG	ZG	ZG1	1	2
32	20	25	45	G1/8	17	M10	45	12	125	9	-	M6	8	33	22	17	15	80	85	0.845	0.0381
40	32	32	52	G1/4	17	M16x1.5	70	18	180	12	5	M6	13	40	40	23	15	110	127	0.956	0.0492
50	32	32	65	G1/4	23	M16x1.5	70	18	180	12	2	M8	13	49	37	23	15	110	124	1.214	0.0628
63	40	45	75	G3/8	23	M20x1.5	85	22	210	13	6	M8	17	59	43	27	20	125	141	2.021	0.0861
80	40	45	95	G3/8	28	M20x1.5	85	22	210	13	6	M10	17	75	37	27	20	125	135	3.055	0.1373
100	54	55	115	G1/2	28	M27x2	110	32	255	16	6	M10	22	90	51	32	20	145	164	5.147	0.1827
125	54	55	140	G1/2	34	M27x2	110	32	255	16	6	M12	22	110	51	32	20	145	164	7.126	0.2513
160	72	65	180	G3/4	42	M36x2	135	40	315	20	10	M16	32	140	57	43	25	180	194	13.694	0.3653
200	72	65	220	G3/4	42	M36x2	135	40	315	20	10	M16	32	175	57	43	25	180	194	19.256	0.4872

\* Other stroke lengths manufactured after prior technical consultation.

\*\* For cylinders with a single-sided piston rod and aluminium tube (1) Cylinder weight with 0 mm stroke (2) Weight increase for every additional 10 mm stroke.

### TECHNICAL SPECIFICATIONS

<b>Maximum operating pressure:</b>	10 bar	
<b>Medium:</b>	compressed air, filtered, lubricated or non-lubricated	
<b>Construction materials:</b>		
<b>Covers, piston</b>	- aluminium alloy	
<b>Piston rod</b>	- chrome-plated carbon steel, acid-resistant steel	
<b>Tube</b>	- aluminium alloy, chrome-plated carbon steel, carbon steel	
<b>Sealing</b>	- polyurethane (working temperature from -20 to +80°C)	
<b>Diameters:</b>	D32-D200	
<b>Standard stroke range:</b>	5-500 mm*	

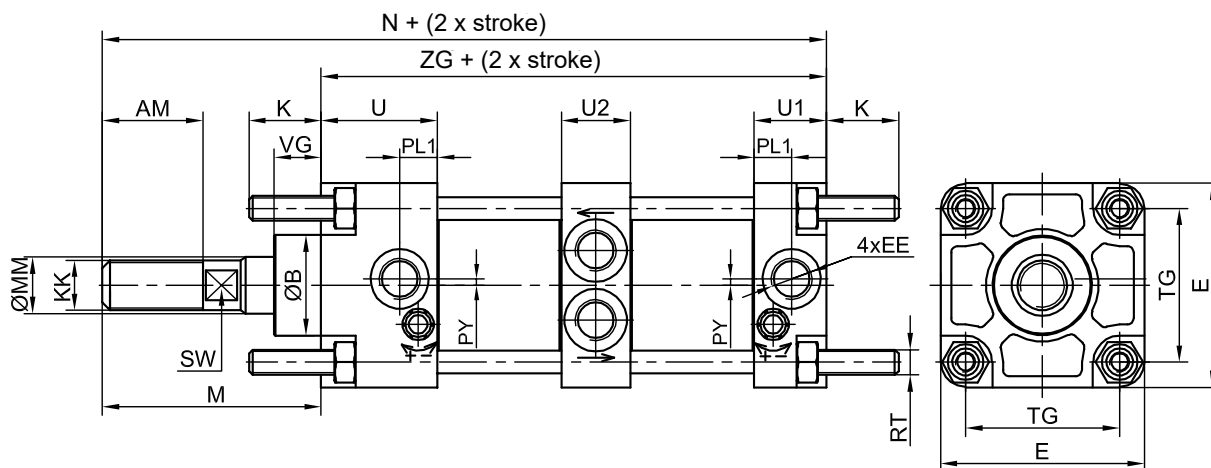

Cylinder diameter [mm]	Dimension [mm]																		
	AM	ØB e9	E	EE	K	KK	M	ØMM f8	N	PL1	PY	RT	SW	TG	U	U1	U2	VG	ZG
32	20	25	45	G1/8	17	M10	45	12	184	9	-	M6	8	33	22	17	18	15	139
40	32	32	52	G1/4	17	M16x1.5	70	18	249	12	4	M6	13	40	40	23	22	15	179
50	32	32	65	G1/4	23	M16x1.5	70	18	252	12	2	M8	13	49	37	23	22	15	182
63	40	45	75	G3/8	23	M20x1.5	85	22	289	13	6	M8	17	59	43	27	24.6	20	204
80	40	45	95	G3/8	28	M20x1.5	85	22	296	13	6	M10	17	75	37	27	25	20	211
100	54	55	115	G1/2	28	M27x2	110	32	349	16	6	M10	22	90	51	32	32	20	239
125	54	55	140	G1/2	34	M27x2	110	32	349	16	6	M12	22	110	51	32	32	20	239
160	72	65	180	G3/4	42	M36x2	135	40	431	20	10	M16	32	140	57	43	36	25	296
200	72	65	220	G3/4	42	M36x2	135	40	431	20	10	M16	32	175	57	43	36	25	296

**Note:**The calculation of the operating force of a TANDEM cylinder can be found on page: no. 3  
\*Other stroke lengths manufactured after prior technical consultation.

## ORDER NUMBER CONSTRUCTION

**11 . 001 H . 0250 A \_**

**Type**  
**10** - standard cylinder  
**11** - cylinder with magnet (BSPT)

**Cylinder variety code**  
**001** - with single-sided piston rod  
**002** - with double-sided piston rod  
**003** - TANDEM

**Diameter code**  
**E** - 32 mm  
**F** - 40 mm  
**G** - 50 mm  
**H** - 63 mm  
**J** - 80 mm  
**K** - 100 mm  
**L** - 125 mm  
**M** - 160 mm  
**N** - 200 mm

**Stroke [mm]**  
 stroke e.g. 0250 = 250 mm

**Tube type\***  
**Without designation** - steel  
**A** - aluminium alloy  
**C** - chrome-plated steel

**Additional designations\***  
**Without designation** - standard cylinder  
**K** - piston rod, stud bolts and nuts made of acid-resistant steel  
**T** - high-temperature version VITON  
**J** - version with attached Central Trunnion

**Example cylinder designation: 11.001K.0200AKT**  
 Version: cylinder according to CNOMO standard D100x200 with magnet (BPST), with aluminium tube, piston rod, stud bolts and nuts made of acid-resistant steel, high temperature version VITON

## ORDERING PROCEDURE

The order should include: name, nominal diameter, cylinder stroke, order number and the number of pieces, e.g.:  
**Cylinder SCN D63 x 250 no. 11.001H.0250A 1 pc.**

## ADDITIONAL ELEMENTS

Mounting elements for SCN series cylinders	page 1.17.01.02-03
Repair kits for SCN series cylinders	page 1.18.11

**Note:** we manufacture multi-chamber cylinders.  
 \* Other versions after technical consultation





### TECHNICAL SPECIFICATIONS

<b>Maximum operating pressure:</b>	10 bar	
<b>Medium:</b>	compressed air, filtered, lubricated or non-lubricated	
<b>Construction materials:</b>		
<b>Covers, piston</b>	- aluminium alloy	
<b>Body</b>	- aluminium alloy	
<b>Piston rod, guides</b>	- chrome-plated carbon steel, acid-resistant steel	
<b>Sealing</b>	- polyurethane (working temperature from -20 to +80°C)	
<b>Diameters:</b>	D16–D100	
<b>Standard stroke range:</b>	5–100 mm* (for versions 030, 032, 130, 132) 5–50 mm* (for versions 031, 131)	



### CYLINDER WITH SINGLE-SIDED PISTON ROD

### CYLINDER WITH DOUBLE-SIDED PISTON ROD

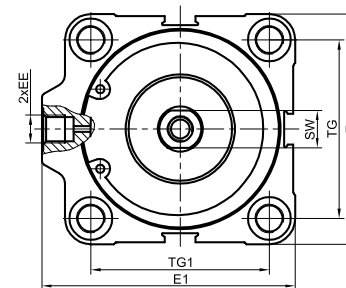
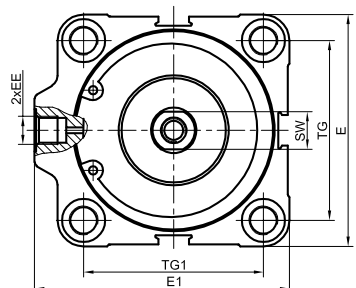
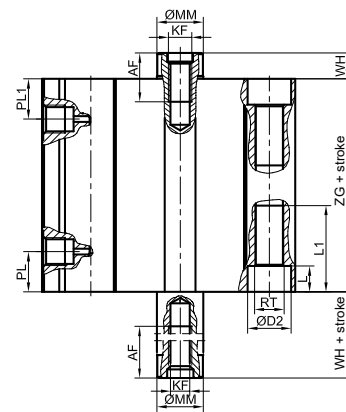
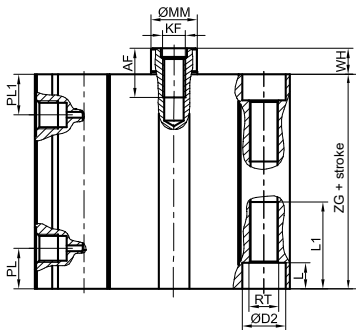

Cylinder diameter [mm]	Dimension [mm]																
	AF	ØD2	E	E1	EE	KF	L	L1	ØMM	PL	PL1	RT	SW	TG	TG1	WH	ZG
16	8	6	28	31	M5	M4	4	13	8	6	12	M4	6	20	20	4.5	
20	12	7.5	32	35	M5	M5	4.5	16	10	6	15	M5	8	22	22	6	
25	12	7.5	38	44.5	M5	M5	4.5	16	10	9.5	9.5	M5	8	26	28	6	
32	14	10.4	45	54	G1/8	M6	6	22	12	11.5	11.5	M6	10	32	36	6.5	
40	14	10.4	54.5	60	G1/8	M6	6	22	12	12	12	M6	10	40	40	6.5	
50	14	11	65	72.5	G1/8	M8	9	30	16	13	13	M8	13	50	50	8	
63	17	13.5	80	88	G1/8	M8	9	30	16	14	14	M10	13	62	62	9	
80	17	13.5	100	110	G1/4	M10	9	30	20	16	16	M10	17	82	82	9	
100	20	16.5	124	134	G1/4	M12	10.5	35.5	25	18	18	M12	22	103	103	10	

\*\*dimensions in the table on page: 1.08.02

\* Other stroke lengths manufactured after prior technical consultation.

### PRESSURE CYLINDER WITH ANTI-ROTATION PISTON ROD PROTECTION

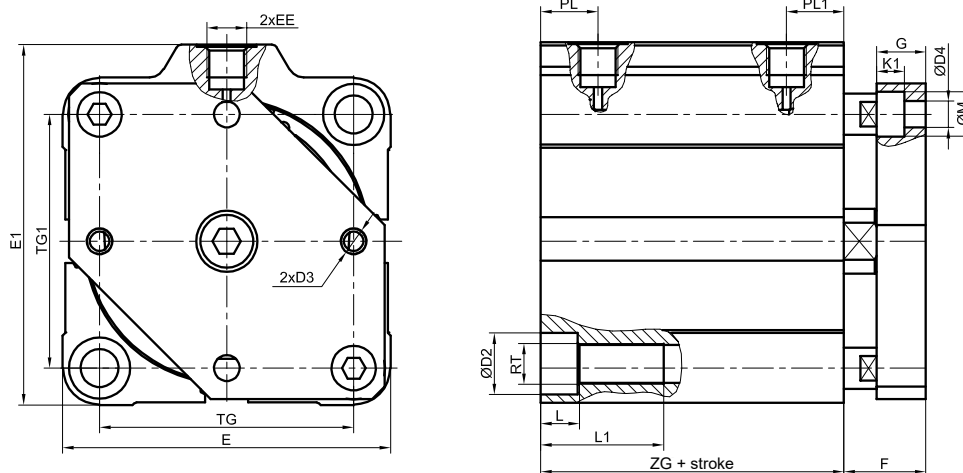

Cylinder diameter [mm]	Dimension [mm]																
	RT	ØD2	ØD3	ØD4	E	E1	EE	F	G	L	L1	PL	PL1	TG	TG1	K1	ZG
16	M4	6	M3	M3	28	31	M5	10.5	6	4	13	6	12	20	20	-	**dimensions in the table below
20	M5	7.5	M4	M4	32	35	M5	10	8	4.5	16	6	15	22	22	-	
25	M5	7.5	M4	M4	38	44.5	M5	10	8	4.5	16	9.5	9.5	26	28	-	
32	M6	10.4	M5	5.5	45	54	G1/8	16.5	10	6	22	11	11	32	36	6	
40	M6	10.4	M5	5.5	54.5	60	G1/8	16.5	10	6	22	11	11	40	40	6	
50	M8	11	M5	6	65	72.5	G1/8	20	12	9	30	11.5	11.5	50	50	6	
63	M10	13.5	M6	6.4	80	88	G1/8	21	12	9	30	13	13	62	62	6.8	
80	M10	13.5	M6	6.4	100	110	G1/4	24	15	9	30	15	15	82	82	6.8	
100	M12	16.5	M8	9	124	134	G1/4	25	15	10.5	35.5	17	17	103	103	9	

Diameter D of the cylinder	Series	Stroke	ZG**
16	030	0-100	29
	031	0-25	34
	032	0-100	39
20	030	0-100	32
	031	0-25	37
	032	0-100	42
25	030	0-100	40
	031	0-25	45
	032	0-100	45
32	130	0-100	40
	131	0-25	40
		26-50	54
40	132	0-100	40
	130	0-100	45
		0-25	45
50	131	26-50	63
		0-100	45
	132	0-100	45
63	130	0-100	50
		0-25	50
	26-50	70	
80	132	0-100	50
		0-100	54
	130	0-100	54
100	131	0-25	54
		26-50	74
	132	0-100	54
100	130	0-100	59
		0-25	59
	26-50	85	
100	131	0-100	59
		0-25	66
	26-50	66	
100	132	0-100	92
		0-100	66

## PRESSURE CYLINDER WITH MALE THREAD

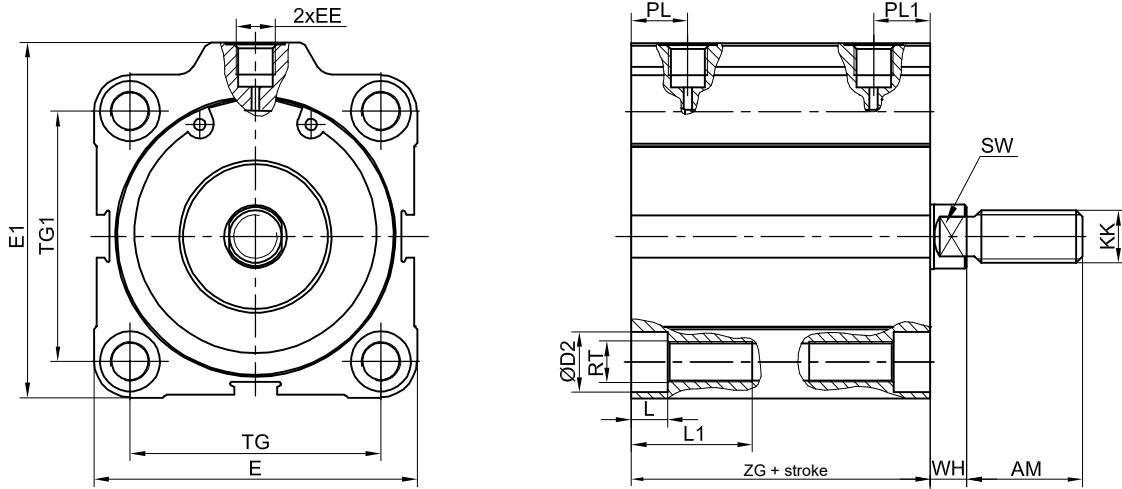

Cylinder diameter [mm]	Dimension [mm]			
	AM	KK	SW	WH
16	20	M8	6	4.5
20	22	M10x1.25	8	4.5
25	22	M10x1.25	8	5.5
32	19	M10x1.25	10	7
40	19	M10x1.25	10	7
50	22	M12x1.25	13	8
63	22	M12x1.25	13	8
80	28	M16x1.5	16	10
100	32	M16x1.5	21	10

## ORDER NUMBER CONSTRUCTION

### FOR CYLINDERS D16 – D25

**11 . 030 B . 0025**

#### Type

10 - standard cylinder  
11 - cylinder with magnet (BSPT)

#### Cylinder variety code

030 - with single-sided double-acting piston rod  
031 - with single-sided single-acting pushing piston rod  
032 - with double-sided double-acting piston rod

#### Diameter code

B - 16 mm  
C - 20 mm  
D - 25 mm

#### Stroke [mm]

stroke e.g. 0025 = 25 mm

#### Additional designation

Without designation - standard cylinder  
GZ - piston rod with male thread  
K - acid-resistant steel piston rod  
ZT - with anti-rotation protection (for variety 030)

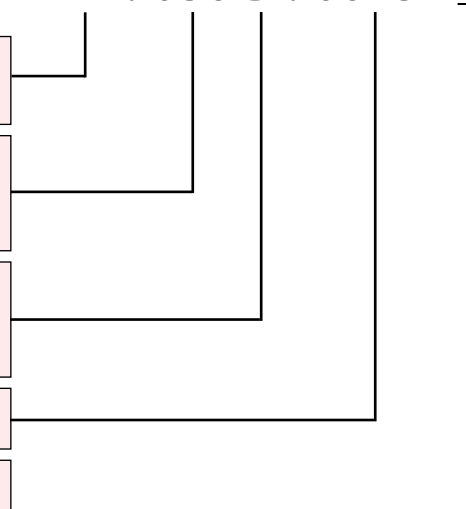

### ORDER NUMBER CONSTRUCTION

#### FOR CYLINDERS D32 – D100

**11 . 130 G . 0025**

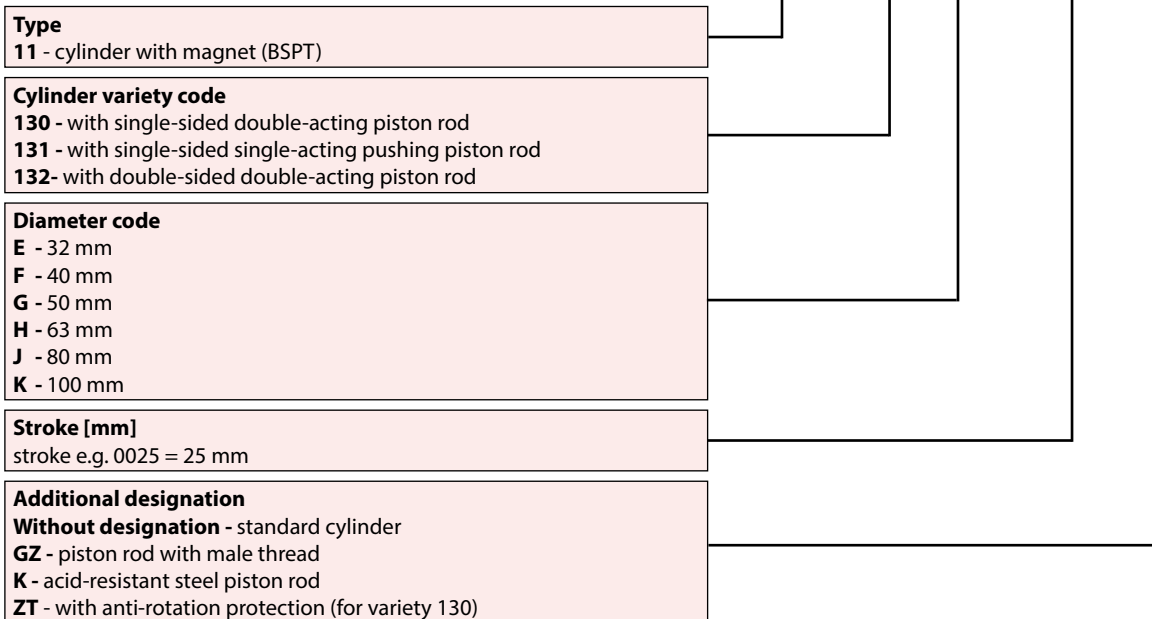

### ORDERING PROCEDURE

The order should include: name, nominal diameter, cylinder stroke, order number and the number of pieces, e.g.:

**Cylinder SDK D50 x 25 no. 11.130G.0025 1 pc.**

### ADDITIONAL ELEMENTS

Repair kits for SDK series cylinders

page 1.18.12-13

### TECHNICAL SPECIFICATIONS

<b>Maximum operating pressure:</b>	10 bar	
<b>Medium:</b>	compressed air, filtered, lubricated or non-lubricated	
<b>Construction materials:</b>		
<b>Covers, piston</b> - aluminium alloy <b>Body</b> - aluminium alloy <b>Piston rod, guides</b> - chrome-plated carbon steel, acid-resistant steel <b>Sealing</b> - polyurethane (working temperature from -20 to +80°C)		
<b>Diameters:</b>	D16-D100	
<b>Standard stroke range:</b>	5-200 mm* (for varieties 040, 041, 050, 051) 5-50 mm* (for varieties 042, 052) 5-25 mm* (for varieties 043, 053)	



**COMPACT CYLINDER D16-D25**  
**DOUBLE-ACTING**  
**WITH SINGLE-SIDED PISTON ROD**

**COMPACT CYLINDER D32 - D100**  
**DOUBLE-ACTING**  
**WITH SINGLE-SIDED PISTON ROD**

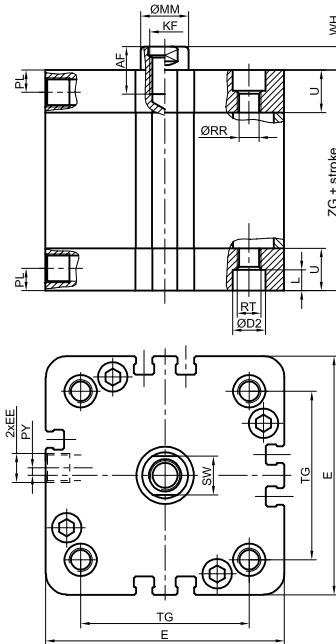
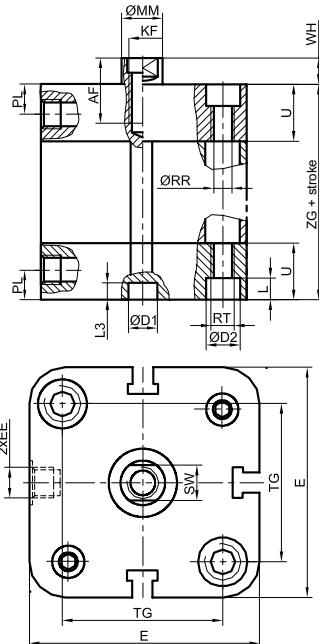

Cylinder diameter [mm]	Dimension [mm]																	
	AF	ØD1	ØD2	E	EE	KF	L	L3	ØMM	PL	PY	ØRR	RT	SW	TG	U	WH	ZG
16	8	6	6	29	M5	M4	3.5	4	8	8	-	3.3	M4	6	18	12.25	4.5	38
20	10	6	7.5	36	M5	M5	4.5	4	10	8	-	4.2	M5	8	22	12.25	4.5	38
25	10	6	7.5	40	M5	M5	4.5	4	10	8	-	4.2	M5	8	26	12.75	5.5	39.5
32	12	-	9.2	50	G1/8	M8	6	-	12	8	4	5.2	M6	10	32.5	14.5	7	44
40	12	-	9.2	58	G1/8	M8	6	-	12	8	3	5.2	M6	10	38	14.5	7	45
50	16	-	11	67	G1/8	M10	7	-	16	7.5	-	6.8	M8	13	46.5	14.25	8	45
63	16	-	11	80	G1/8	M10	7	-	16	7.5	-	6.8	M8	13	56.5	14.25	8	49
80	20	-	14.5	100	G1/8	M12	9	-	20	8	-	8.5	M10	16	72	15.5	10	54
100	24	-	14.5	124	G1/8	M12	9	-	25	10	-	8.5	M10	21	89	20	10	67

**Note:** cylinders with diameters D32 and D40 have 3 channels for mounting magnetic field sensors.  
The D50, D63, D80 and D100 diameter cylinders have 7 channels for mounting magnetic field sensors.  
\*Other stroke lengths manufactured after prior technical consultation.

# SKP SERIES

## Compact cylinders

according to ISO 21287



### COMPACT CYLINDER D16 – D25 DOUBLE-ACTING WITH ANTI-ROTATION PROTECTION

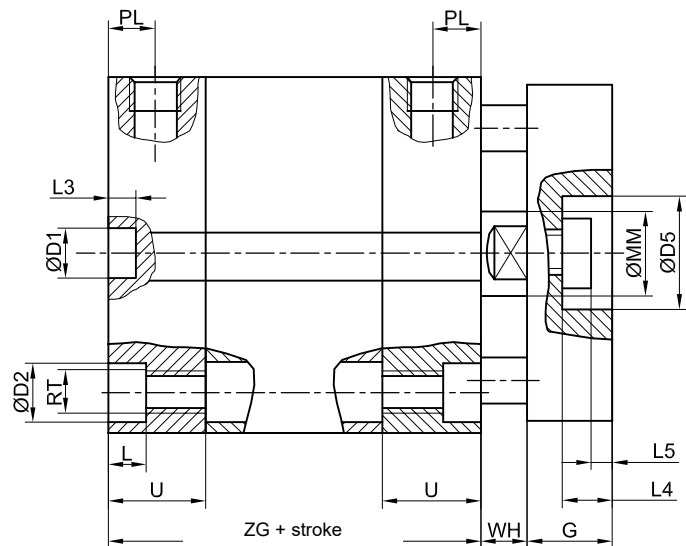
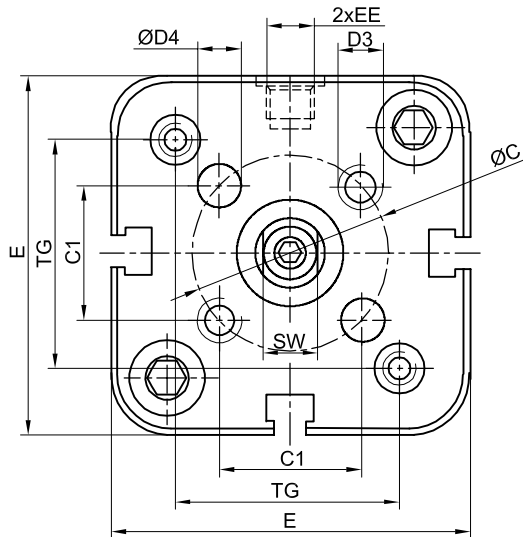

### COMPACT CYLINDER D32 – D100 DOUBLE-ACTING WITH ANTI-ROTATION PROTECTION

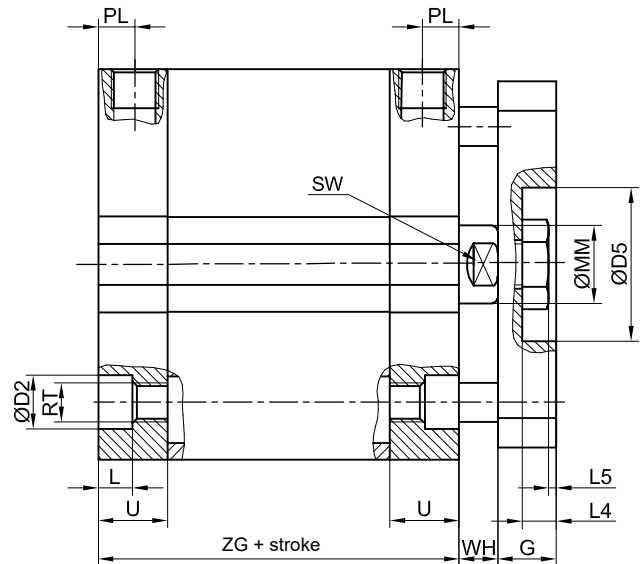
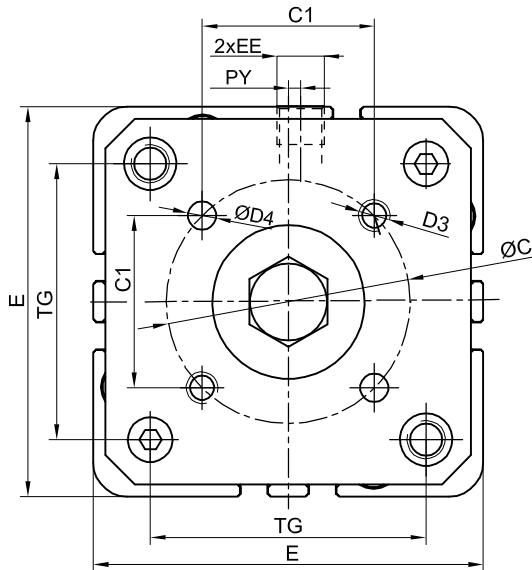

Cylinder diameter [mm]	Dimension [mm]																							
	ØC	C1	ØD1	ØD2	D3	ØD4	ØD5	E	EE	G	L	L3	L4	L5	ØMM	PL	PY	ØRR	RT	SW	TG	U	WH	ZG
16	14	9.9	6	6	M3	3	9	29	M5	6	3.5	4	3.8	1	8	8	-	3.3	M4	6	18	12.25	4.5	38
20	17	12	6	7.5	M4	4	11	36	M5	8	4.5	4	5	1.5	10	8	-	4.2	M5	8	22	12.25	4.5	38
25	22	15.5	6	7.5	M5	5	14	40	M5	8	4.5	4	5	1.5	10	8	-	4.2	M5	8	26	12.75	5.5	39.5
32	28	19.8	6	9.2	M5	5	17	50	G1/8	10	6	-	6.5	2.5	12	8	4	5.2	M6	10	32.5	14.5	7	44
40	33	23.3	-	9.2	M5	5	17	58	G1/8	10	6	-	6.5	2.5	12	8	3	5.2	M6	10	38	14.5	7	45
50	42	29.7	-	11	M6	6	22	67	G1/8	12	7	-	7.5	2.5	16	7.5	-	6.8	M8	13	46.5	14.25	8	45
63	50	35.4	-	11	M6	6	22	80	G1/8	12	7	-	7.5	2.5	16	7.5	-	6.8	M8	13	56.5	14.25	8	49
80	65	46	-	14.5	M8	8	28	100	G1/8	14	9	-	9	3	20	8	-	8.5	M10	17	72	15.5	10	54
100	80	56.6	-	14.5	M10	10	30	124	G1/8	14	9	-	10	3	25	10	-	8.5	M10	22	89	20	10	67

**Note:** cylinders with diameters D32 and D40 have 3 channels for mounting magnetic field sensors.  
The D50, D63, D80 and D100 diameter cylinders have 7 channels for mounting magnetic field sensors.

### COMPACT CYLINDER D16 – D25 SINGLE-ACTING PUSHING

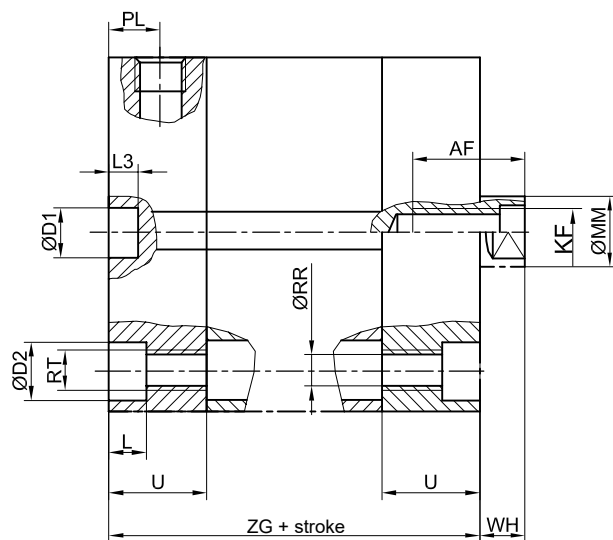
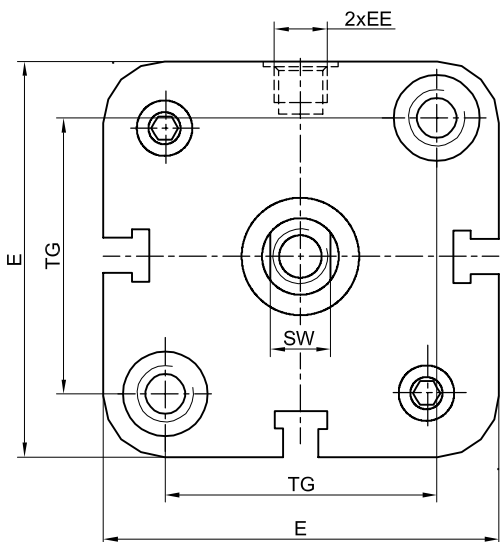

### COMPACT CYLINDER D32 – D100 SINGLE-ACTING PUSHING

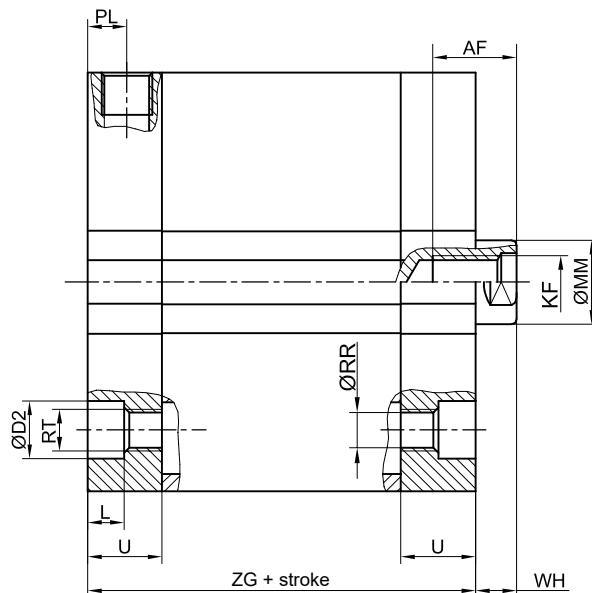
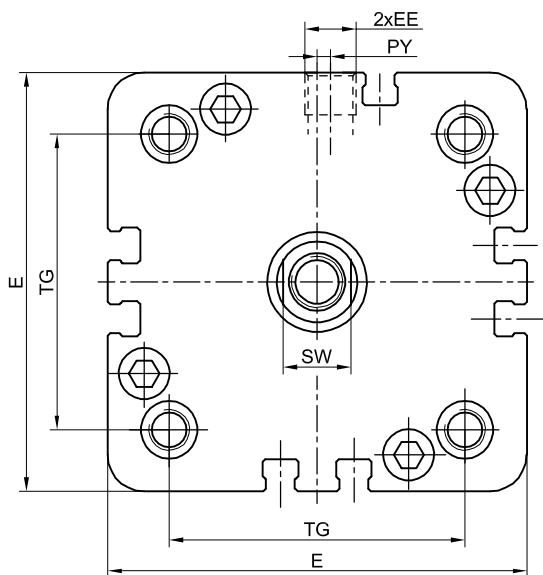

Cylinder diameter [mm]	Dimension [mm]																ZG dimensions [mm]		
	AF	ØD1	ØD2	E	EE	KF	L	L3	ØMM	PL	PY	ØRR	RT	SW	TG	U	WH	for 0-25 mm stroke	for 26-50 mm stroke
16	8	6	6	29	M5	M4	3.5	4	8	8	-	3.3	M4	6	18	12.25	4.5	38	48
20	10	6	7.5	36	M5	M5	4.5	4	10	8	-	4.2	M5	8	22	12.25	4.5	38	48
25	10	6	7.5	40	M5	M5	4.5	4	10	8	-	4.2	M5	8	26	12.75	5.5	39.5	59.5
32	12	-	9.2	50	G1/8	M8	6	-	12	8	4	5.2	M6	10	32.5	14.5	7	44	57.5
40	12	-	9.2	58	G1/8	M8	6	-	12	8	3	5.2	M6	10	38	14.5	7	45	62.5
50	16	-	11	67	G1/8	M10	7	-	16	7.5	-	6.8	M8	13	46.5	14.25	8	45	65
63	16	-	11	80	G1/8	M10	7	-	16	7.5	-	6.8	M8	13	56.5	14.25	8	49	69
80	20	-	14.5	100	G1/8	M12	9	-	20	8	-	8.5	M10	16	72	15.5	10	54	80
100	24	-	14.5	124	G1/8	M12	9	-	25	10	-	8.5	M10	21	89	20	10	67	92.5

**Note:** cylinders with diameters D32 and D40 have 3 channels for mounting magnetic field sensors. The D50, D63, D80 and D100 diameter cylinders have 7 channels for mounting magnetic field sensors.



# SKP SERIES

## Compact cylinders

according to ISO 21287



### COMPACT CYLINDER D16 – D25 DOUBLE-ACTING WITH DOUBLE-SIDED PISTON ROD

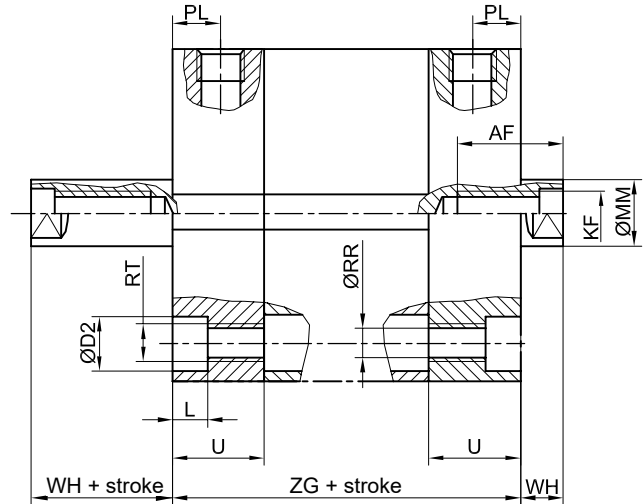
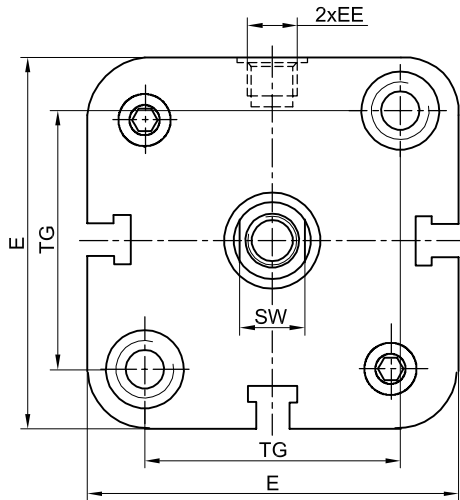

### COMPACT CYLINDER D32 – D100 DOUBLE-ACTING WITH DOUBLE-SIDED PISTON ROD

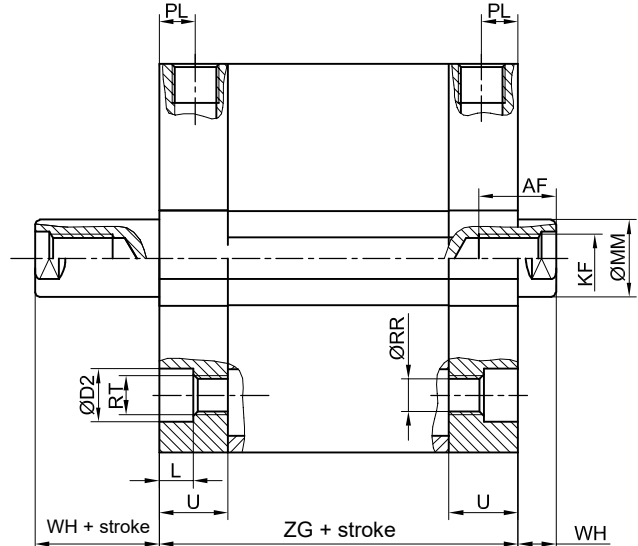
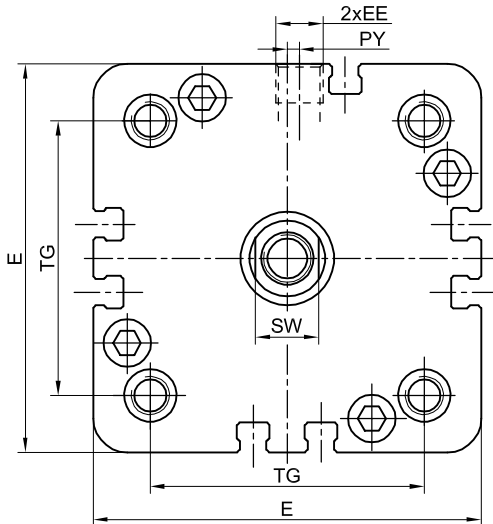

Cylinder diameter [mm]	Dimension [mm]															
	AF	ØD2	E	EE	KF	L	ØMM	PL	PY	ØRR	RT	SW	TG	U	WH	ZG
16	8	6	29	M5	M4	3,5	8	8	-	3,3	M4	6	18	12,25	4,5	38
20	10	7,5	36	M5	M5	4,5	10	8	-	4,2	M5	8	22	12,25	4,5	38
25	10	7,5	40	M5	M5	4,5	10	8	-	4,2	M5	8	26	12,75	5,5	39,5
32	12	9,2	50	G1/8	M8	6	12	8	4	5,2	M6	10	32,5	14,5	7	44
40	12	9,2	58	G1/8	M8	6	12	8	3	5,2	M6	10	38	14,5	7	45
50	16	11	67	G1/8	M10	7	16	7,5	-	6,8	M8	13	46,5	14,25	8	45
63	16	11	80	G1/8	M10	7	16	7,5	-	6,8	M8	13	56,5	14,25	8	49
80	20	14,5	100	G1/8	M12	9	20	8	-	8,5	M10	16	72	15,5	10	54
100	24	14,5	124	G1/8	M12	9	25	10	-	8,5	M10	21	89	20	10	67

**Note:** cylinders with diameters D32 and D40 have 3 channels for mounting magnetic field sensors. The D50, D63, D80 and D100 diameter cylinders have 7 channels for mounting magnetic field sensors.

## COMPACT CYLINDER D16 – D25 SINGLE-ACTING PULLING

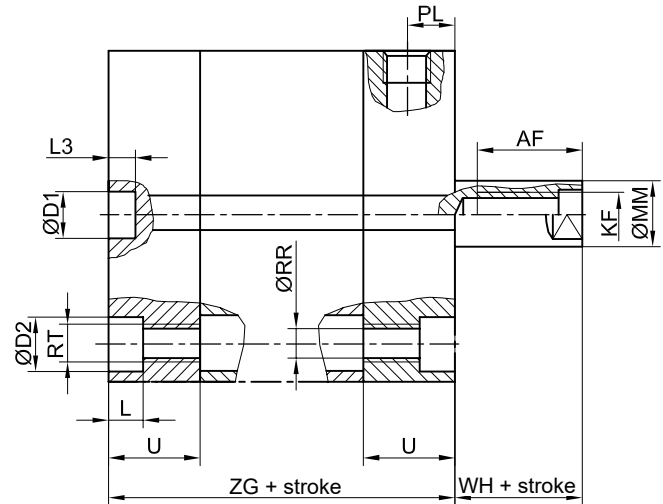
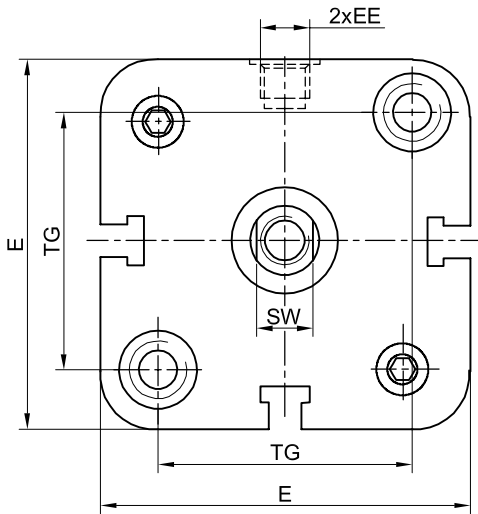

## COMPACT CYLINDER D32 – D100 SINGLE-ACTING PULLING

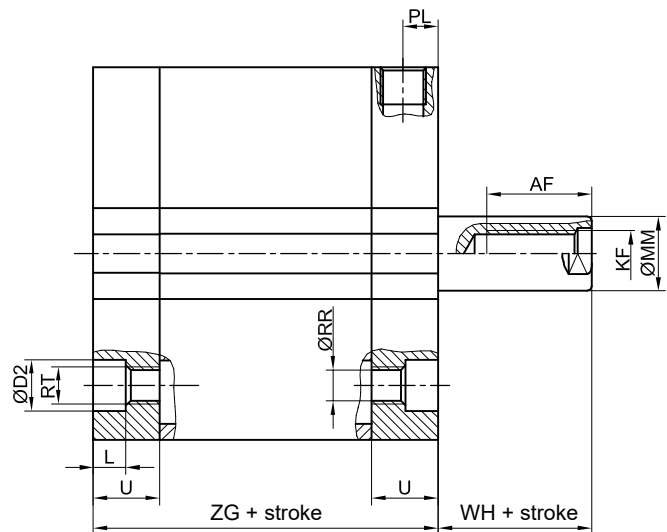
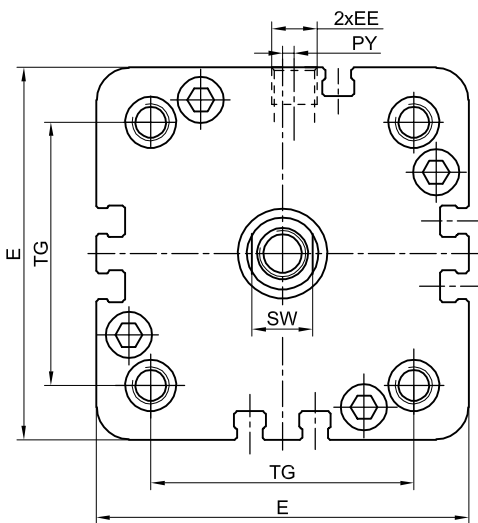

Cylinder diameter [mm]	Dimension [mm]																		
	AF	ØD1	ØD2	E	EE	KF	L	L3	ØMM	PL	PY	ØRR	RT	SW	TG	U	WH	ZG	
16	8	6	6	29	M5	M4	3.5	4	8	8	-	3.3	M4	6	18	12.25	4.5	38	
20	10	6	7.5	36	M5	M5	4.5	4	10	8	-	4.2	M5	8	22	12.25	4.5	38	
25	10	6	7.5	40	M5	M5	4.5	4	10	8	-	4.2	M5	8	26	12.75	5.5	39.5	
32	12	-	9.2	50	G1/8	M8	6	-	12	8	4	5.2	M6	10	32.5	14.5	7	44	
40	12	-	9.2	58	G1/8	M8	6	-	12	8	3	5.2	M6	10	38	14.5	7	45	
50	16	-	11	67	G1/8	M10	7	-	16	7.5	-	6.8	M8	13	46.5	14.25	8	45	
63	16	-	11	80	G1/8	M10	7	-	16	7.5	-	6.8	M8	13	56.5	14.25	8	49	
80	20	-	14.5	100	G1/8	M12	9	-	20	8	-	8.5	M10	16	72	15.5	10	54	
100	24	-	14.5	124	G1/8	M12	9	-	25	10	-	8.5	M10	21	89	20	10	67	

**Note:** cylinders with diameters D32 and D40 have 3 channels for mounting magnetic field sensors.  
The D50, D63, D80 and D100 diameter cylinders have 7 channels for mounting magnetic field sensors.

### VALUES OF THE ACTUATING FORCES OF COMPACT CYLINDERS

Diameter of the cylinder [mm]	Double-acting cylinders with single-sided piston rod		Double-acting cylinders with double-sided piston rod		Single-acting cylinders pulling		Single-acting cylinders pushing	
	Pushing force at 6 bar supply [N]	Pulling force at 6 bar supply [N]	Pushing force at 6 bar supply [N]	Pulling force at 6 bar supply [N]	Pushing force at 6 bar supply [N]	Spring pulling force [N]	Pulling force at 6 bar supply [N]	Spring pushing force [N]
16	121	91	91	91	110	6	81	6
20	188	142	142	142	174	7	128	7
25	295	248	248	248	270	12	224	12
32	482	415	415	415	450	16	384	16
40	754	687	687	687	708	23	642	23
50	1178	1058	1058	1058	1120	30	1002	30
63	1869	1750	1750	1750	1800	35	1682	35
80	3014	2829	2829	2829	2900	60	2715	60
100	4710	4420	4420	4420	4520	100	4231	100

### VERSION WITH MALE THREAD ON THE PISTON ROD

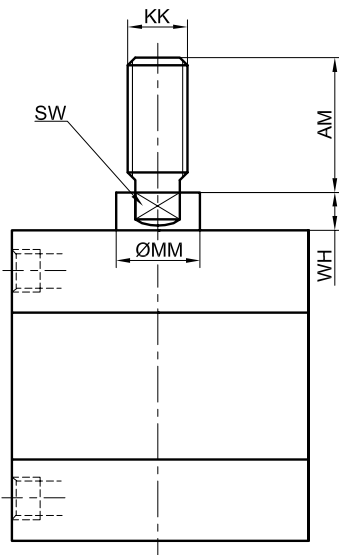

Diameter of the cylinder [mm]	Dimension [mm]				
	AM	KK	ØMM f8	SW	WH
16	20	M8	8	6	4.5
20	22	M10×1.25	10	8	4.5
25	22	M10×1.25	10	8	5.5
32	19	M10×1.25	12	10	7
40	19	M10×1.25	12	10	7
50	22	M12×1.25	16	13	8
63	22	M12×1.25	16	13	8
80	28	M16×1.5	20	16	10
100	32	M16×1.5	25	21	10

### ADDITIONAL ELEMENTS

Mounting elements for SKP series cylinders	page 1.17.01.10
Repair kits for SKP series cylinders	page 1.18.14

## ORDER NUMBER CONSTRUCTION

### FOR CYLINDERS WITH DIAMETER D16 –D25

**11 . 040 B . 0100 ZT**

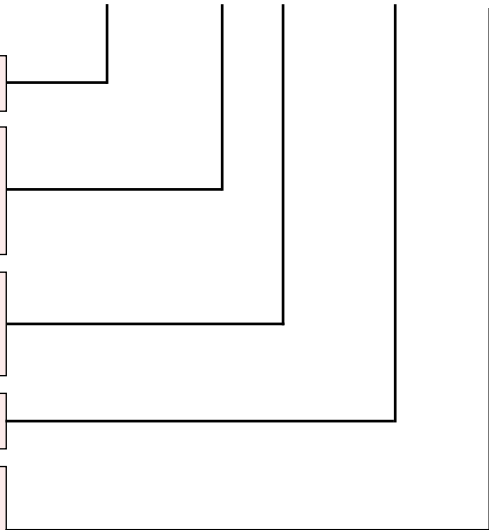
<b>Type</b> 11 - cylinder with magnet (BSPT)	
<b>Cylinder variety code</b> 040 - with single-sided double-acting piston rod 041 - with double-sided double-acting piston rod 042 - with single-sided single-acting pushing piston rod 043 - with single-sided single-acting pulling piston rod	
<b>Diameter code</b> B - 16 mm C - 20 mm D - 25 mm	
<b>Stroke [mm]</b> stroke e.g. 0100 = 100mm	
<b>Version</b> Without designation - standard cylinder K - acid-resistant steel piston rod ZT - with anti-rotation protection GZ - with male thread on the piston rod	

### FOR CYLINDERS WITH DIAMETER D32 –D100

**11 . 050 G . 0100 ZT**

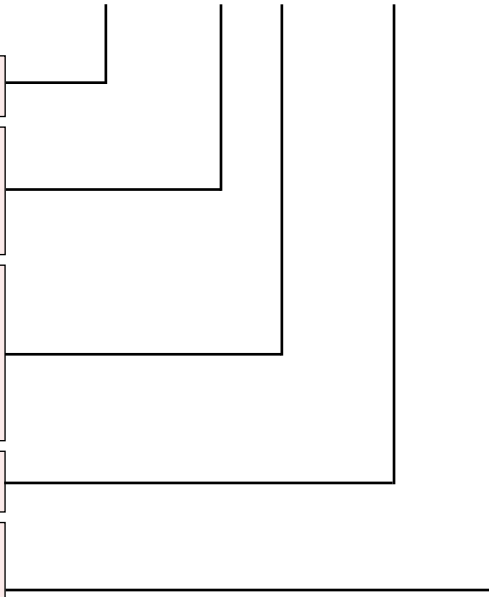
<b>Type</b> 11 - cylinder with magnet (BSPT)	
<b>Cylinder variety code</b> 050 - with single-sided double-acting piston rod 051 - with double-sided double-acting piston rod 052 - with single-sided single-acting pushing piston rod 053 - with single-sided single-acting pulling piston rod	
<b>Diameter code</b> E - 32 mm F - 40 mm G - 50 mm H - 63 mm J - 80 mm* K - 100 mm	
<b>Stroke [mm]</b> stroke e.g. 0100 = 100mm	
<b>Version</b> Without designation - standard cylinder K - acid-resistant steel piston rod ZT - with anti-rotation protection GZ - with male thread on the piston rod	

## ORDERING PROCEDURE

The order should include: name, nominal diameter, cylinder stroke, order number and the number of pieces, e.g.:

**Compact cylinder D50 x 100 no. 11.050G.0100 1 pc.**

\*Body dimensions not in accordance with ISO 21287



### TECHNICAL SPECIFICATIONS

<b>Maximum operating pressure:</b>	10 bar	
<b>Medium:</b>	compressed air, filtered, lubricated or non-lubricated	
<b>Construction materials:</b>		
<b>Covers, piston</b>	- aluminium alloy	
<b>Piston rod</b>	- chrome-plated carbon steel	
<b>Tube</b>	- aluminium alloy	
<b>Sealing</b>	- polyurethane (working temperature from - 20 to + 80°C)	
<b>Diameter:</b>	D25 and D32	
<b>Standard stroke range:</b>	5-100 mm*	



### CYLINDER D25

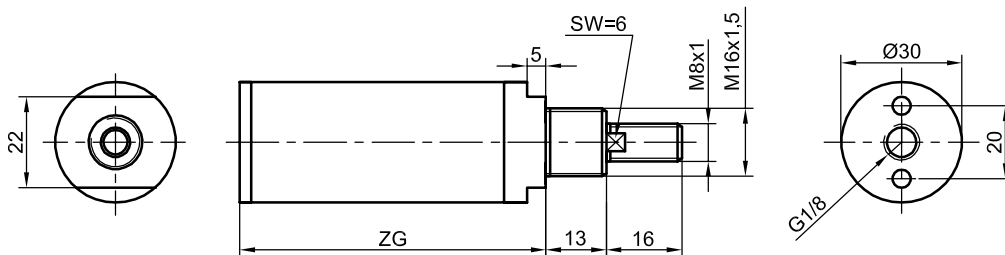

### CYLINDER D32

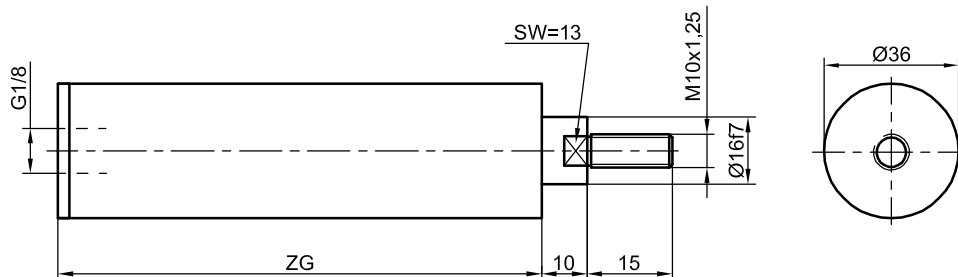

Cylinder diameter [mm]	Dimension [mm]	
	Cylinder stroke	ZG
25	25	77
	32	83.5
32	50	124.5
	80	166

\*Other stroke lengths manufactured after prior technical consultation.

## ORDER NUMBER CONSTRUCTION

**18 . 0382 . 0080**

**Diameter code**  
**18.0382** - 25 mm  
**18.0383** - 32 mm

**Stroke [mm]**  
stroke e.g. 0080= 80 mm

## ORDERING PROCEDURE

The order should include: name, nominal diameter, cylinder stroke, order number and the number of pieces, e.g.:  
**Mini cylinder SCP D32 x 80 no. 18.0383.0080 1 pc.**

## ADDITIONAL ELEMENTS

Repair kits for SCP series cylinders

page 1.18.15

### TECHNICAL SPECIFICATIONS

<b>Maximum operating pressure:</b>	10 bar	
<b>Medium:</b>	compressed air, filtered, lubricated or non-lubricated	
<b>Construction materials:</b>		
<b>Covers, piston</b>	- aluminium alloy	
<b>Piston rod</b>	- chrome-plated carbon steel, acid-resistant steel	
<b>Tube</b>	- aluminium alloy	
<b>Sealing</b>	- polyurethane (working temperature from -20 to +80°C)	
<b>Diameters:</b>	D32–D100	
<b>Standard stroke range:</b>	5–500 mm*	



### DOUBLE ROD CYLINDER WITH SINGLE-SIDED PISTON ROD D32 – D100

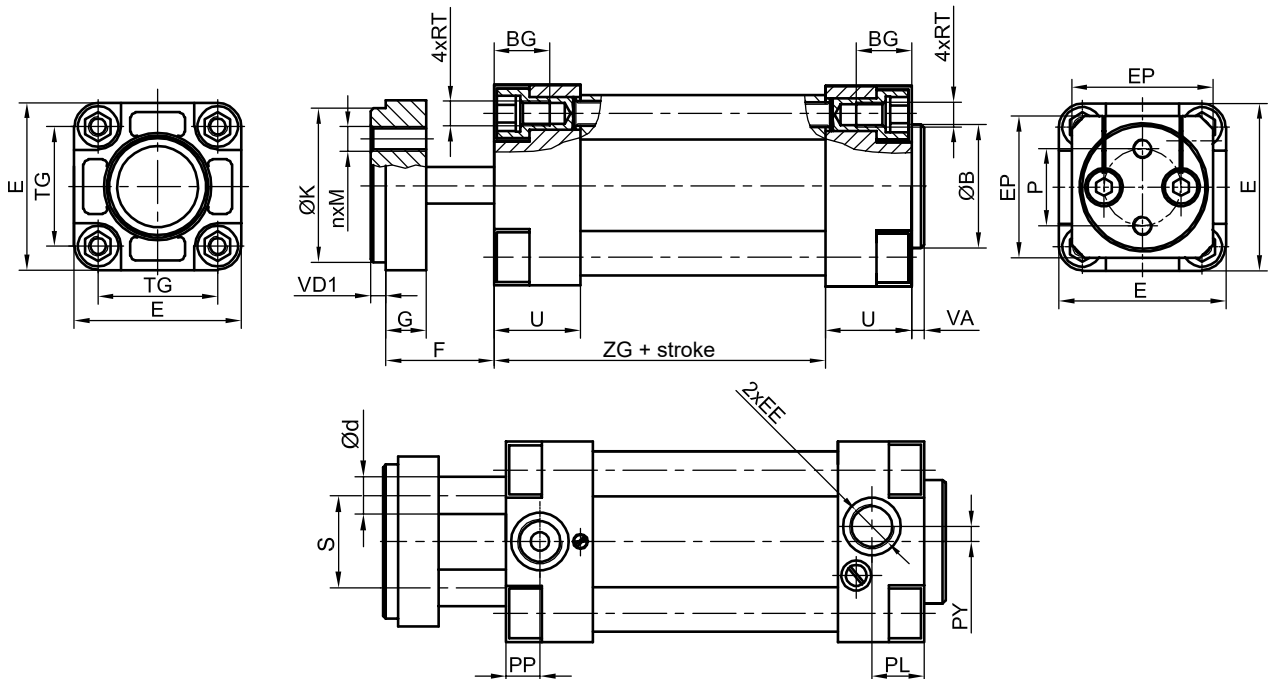

Cylinder diameter [mm]	Dimension [mm]																					
	ØB d11	BG	Ød f8	E	EE	EP	F	G	ØK h9	M	n	P	PP	PL	PY	RT	S	TG	U	VA	VD1	ZG
32	30	15.5	8	46.5	G1/8	45	26	11	32	M6	2	19	11	17	5	M6	19	32.5	26.5	4	4	94
40	35	17.5	10	52	G1/4	45	26	11	40	M6	2	22	12	17	5	M6	22	38	29	4	4	105
50	40	18	12	65	G1/4	55	35	13	50	M8	2	30	11	17	5	M8	30	46.5	28	4	5	106
63	45	20	16	75	G3/8	70	40	17	63	M10	4	38	13	20	6	M8	38	56.5	33	4	5	121
80	45	20.5	20	95	G3/8	90	45	20	80	M12	4	50	13.5	20	6	M10	50	72	33.5	4	5	128
100	55	22.5	20	113	G1/2	110	45	20	100	M12	4	70	16	20	6	M10	70	89	38	4	5	138

\*Other stroke lengths manufactured after prior technical consultation.



### DOUBLE ROD CYLINDER WITH SINGLE PASSING PISTON ROD D32 –D100

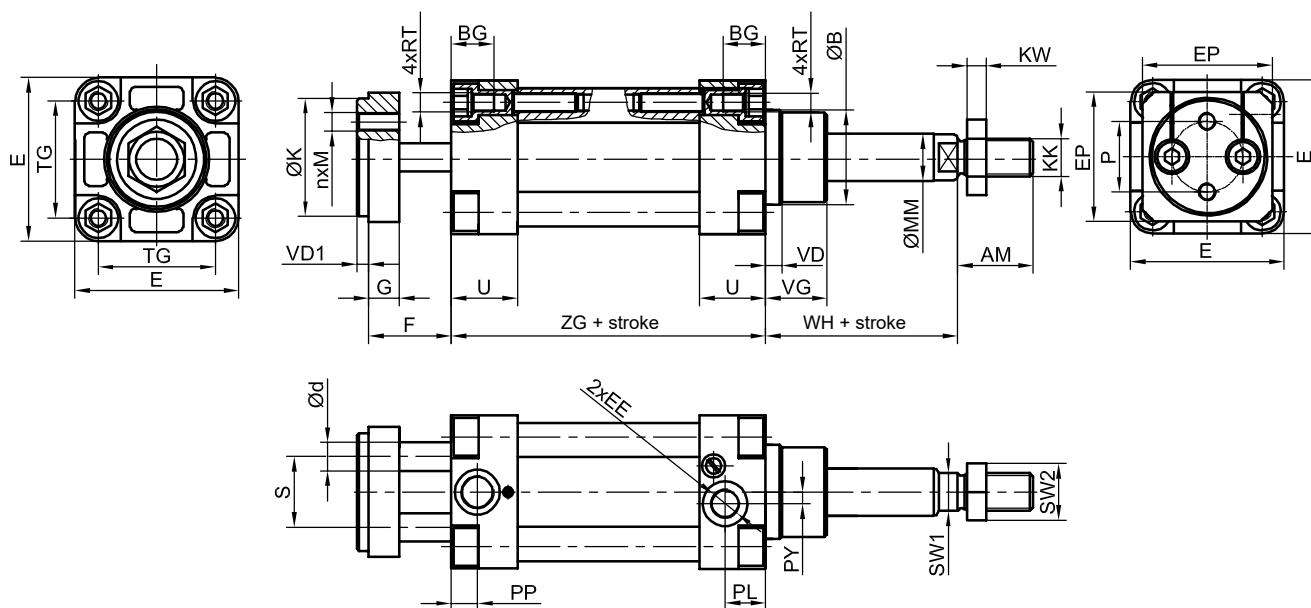

Cylinder diameter [mm]	Dimension [mm]															
	AM	ØB d11	BG	E	EE	KK	KW	ØMM f8	PP	PL	PY	RT	SW1	SW2	TG	U
32	22	30	15.5	46.5	G1/8	M10x1.25	5	12	11	17	5	M6	10	16	32.5	26.5
40	24	35	17.5	52	G1/4	M12x1.25	6	16	12	17	5	M6	13	18	38	29
50	32	40	18	65	G1/4	M16x1.5	8	20	11	17	5	M8	16	24	46.5	28
63	32	45	20	75	G3/8	M16x1.5	8	20	13	20	6	M8	16	24	56.5	33
80	40	45	20.5	95	G3/8	M20x1.5	10	25	13.5	20	6	M10	21	25	72	33.5
100	40	55	22.5	113	G1/2	M20x1.5	10	25	16	20	6	M10	21	30	89	38

Cylinder diameter [mm]	Dimension [mm]														
	Ød f8	EP	F	G	ØK h9	M	n	P	S	VD	VD1	VG	WH	ZG	
32	8	45	26	11	32	M6	2	19	19	6	4	18	26	±1.4	94
40	10	45	26	11	40	M6	2	22	22	6	4	22	30	±1.4	105
50	12	55	35	13	50	M8	2	30	30	6	5	26	37	±1.4	106
63	16	70	40	17	63	M10	4	38	38	6	5	26	37	±1.8	121
80	20	90	45	20	80	M12	4	50	50	6	5	32	46	±1.8	128
100	20	110	45	20	100	M12	4	70	70	6	5	36	51	±1.8	138

### DOUBLE ROD CYLINDER WITH DOUBLE PASSING PISTON ROD D32 –D100

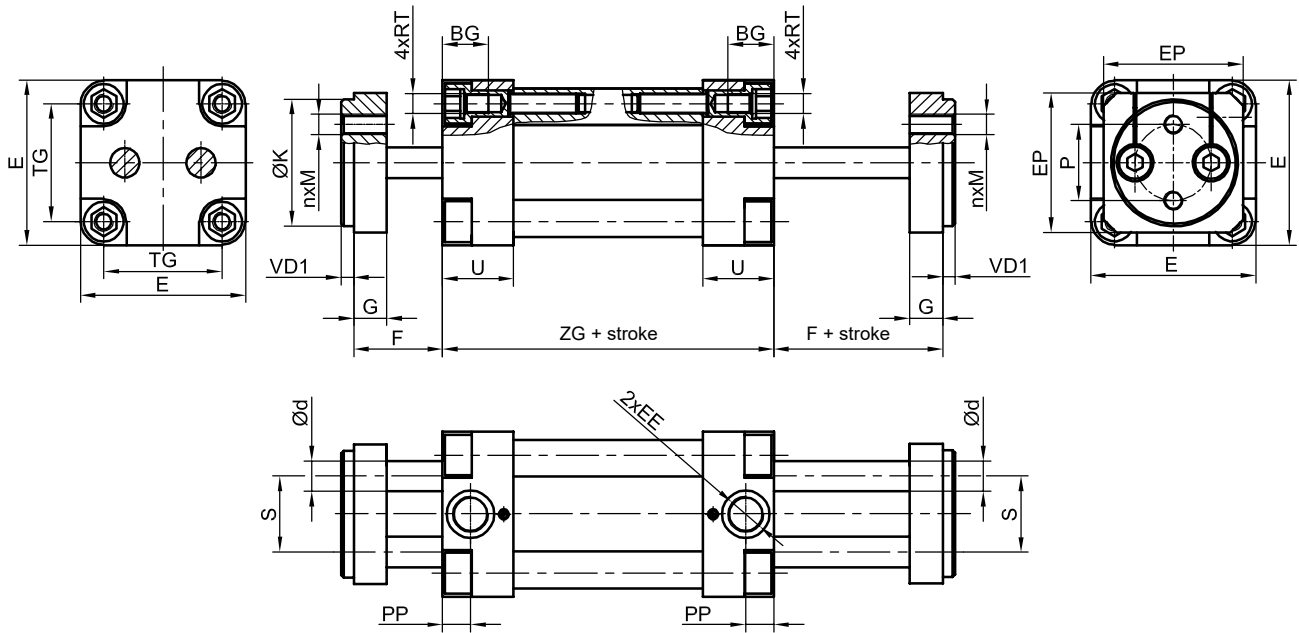

Cylinder diameter [mm]	Dimension [mm]																	
	BG	Ød f8	E	EE	EP	F	G	ØK h9	M	n	P	PP	RT	S	TG	U	VD1	ZG
32	15.5	8	46.5	G1/8	45	26	11	32	M6	2	19	11	M6	19	32.5	26.5	4	102
40	17.5	10	52	G1/4	45	26	11	40	M6	2	22	12	M6	22	38	29	4	115
50	18	12	65	G1/4	55	35	13	50	M8	2	30	11	M8	30	46.5	28	5	118
63	20	16	75	G3/8	70	40	17	63	M10	4	38	13	M8	38	56.5	33	5	131
80	20.5	20	95	G3/8	90	45	20	80	M12	4	50	13.5	M10	50	72	33.5	5	140
100	22.5	20	113	G1/2	110	45	20	100	M12	4	70	16	M10	70	89	38	5	150

### ORDER NUMBER CONSTRUCTION

**11 . 081 H . 0200 P**

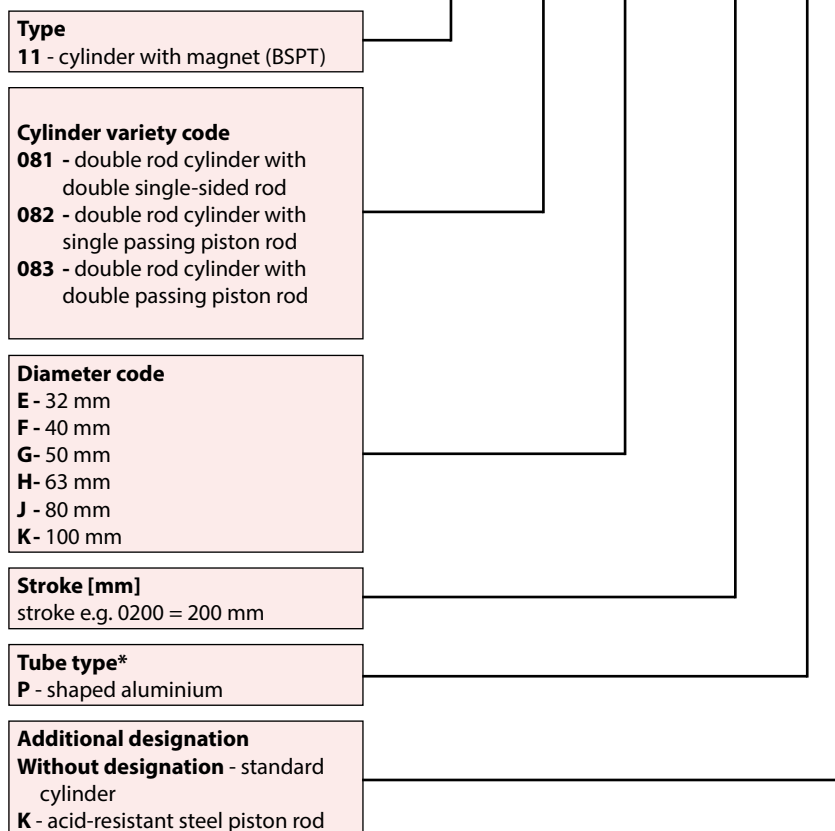

### ORDERING PROCEDURE

The order should include: name, nominal diameter, cylinder stroke, order number and the number of pieces, e.g.:  
**Cylinder SPT D50 x 200 no. 11.083G.0200P 1 pc.**

### ADDITIONAL ELEMENTS

Mounting elements for SPT series cylinders	page 1.17.01.06-07
Repair kits for SPT series cylinders	page 1.18.16

### TECHNICAL SPECIFICATIONS

<b>Maximum operating pressure:</b>	10 bar	
<b>Medium:</b>	compressed air, filtered, lubricated or non-lubricated	
<b>Construction materials:</b>		
<b>Covers, piston, tubes, body</b>	- aluminium alloy	
<b>Toothed gear</b>	- alloy steel	
<b>Sealing</b>	- polyurethane (working temperature from -20 to +80°C)	
<b>Diameters:</b>	D32-D125	
<b>Rotation angle range:</b>	0-360°	



#### Variety with rotation angle adjustment

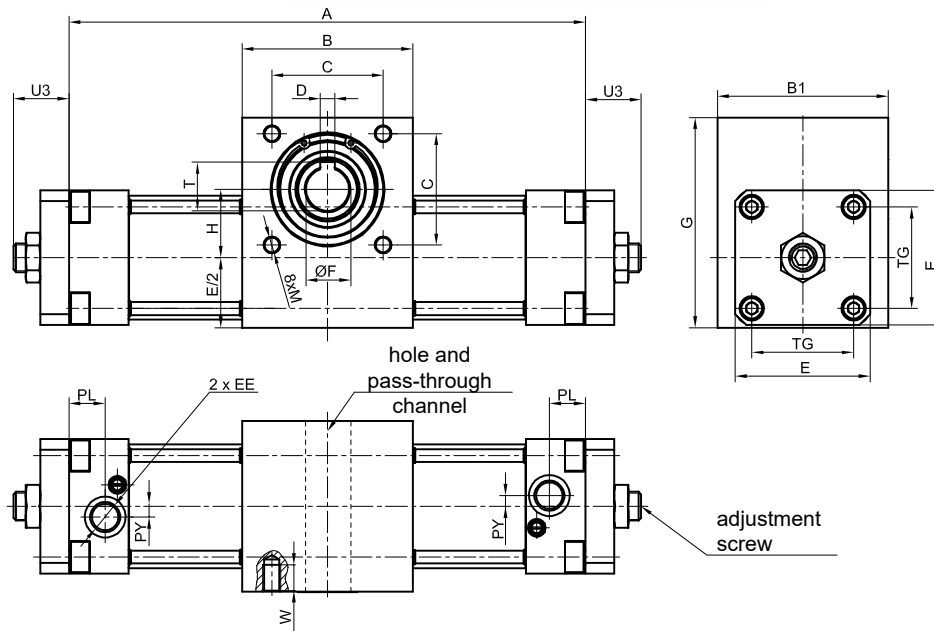

#### Variety without rotation angle adjustment

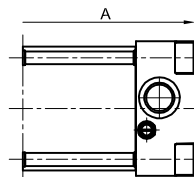

Cylinder diameter [mm]	Dimension [mm]																Dimension A [mm]			
	B	B1	C	DH7	E	EE	ØF H7	G	H	M	PL	PY	T	TG	U3 <sub>max</sub>	W	90°	180°	270°	360°
32	50	55	35	4	46.5	G1/8	10	71	23	M6	17	5	13.5	32.5	25	10	217	263	311	357
40	65	65	47	5	52	G1/4	15	87	28.5	M8	17	5	17.2	38	25	12	261	323	387	449
50	65	65	47	5	65	G1/4	15	94	28.5	M8	17	5	17.2	46.5	25	12	261	323	387	449
63	95	95	62	8	75	G3/8	24	117	38	M10	20	6	27.2	56.5	29	15	336	421	506	591
80	95	95	62	8	95	G3/8	24	126	38	M10	20	6	27.2	72	29	15	340	425	510	595
100	128	142	90	10	113	G1/2	35	175	54	M12	20	6	38.7	89	36	18	434	556	674	794
125	128	142	90	10	140	G/12	35	188	54	M12	33	6	38.7	110	36	18	454	576	694	814

# SWH SERIES

## Rotary cylinders



1

Cylinder diameter [mm]	Theoretical torque M [Nm] at supply pressure [bar]				
	2.0 bar	4.0 bar	6.0 bar	8.0 bar	10 bar
32	2.4	4.8	7.2	9.6	12
40	5	10	15	26	25
50	8	16	24	32	40
63	17	34	51	68	85
80	27	54	81	108	135
100	58	116	174	232	290
125	92	184	276	368	460

### ORDER NUMBER CONSTRUCTION

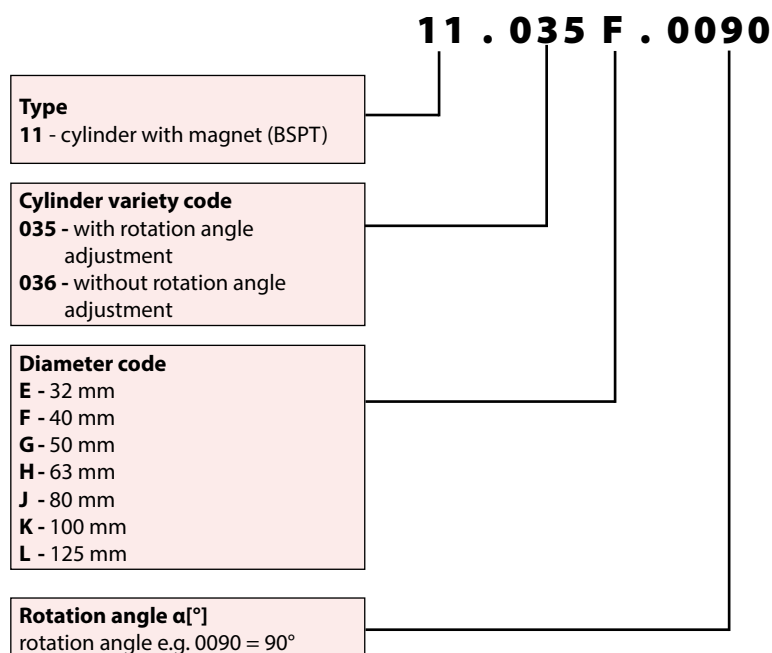

### ORDERING PROCEDURE

The order should include: name, nominal diameter, rotation angle, order number and the number of pieces, e.g.:  
**Cylinder SWH D63  $\alpha=90^\circ$  no. 11.035H.0090 1 pc.**

### ADDITIONAL ELEMENTS

Repair kits for SWH series cylinders	page 1.18.17
--------------------------------------	--------------

### TECHNICAL SPECIFICATIONS

<b>Maximum operating pressure:</b>	10 bar	
<b>Medium:</b>	compressed air, filtered, non-lubricated	
<b>Construction materials:</b>		
<b>Covers, piston</b>	- aluminium alloy	
<b>Piston rod</b>	- acid-resistant steel	
<b>Tube</b>	- aluminium alloy	
<b>Sealing</b>	- polyurethane (working temperature from -20 to +80°C)	
<b>Diameters:</b>	D63–D100	
<b>Standard stroke range:</b>	5–500 mm*	

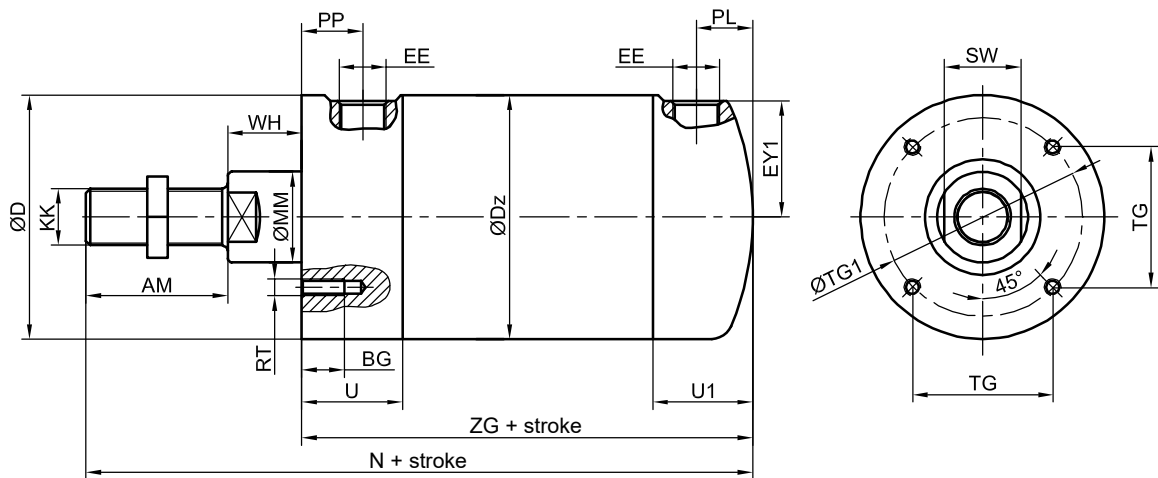

Cylinder diameter [mm]	Dimension [mm]																		
	AM	BG	ØD	ØDz	EE	EY1	KK	ØMM	N	PL	PP	RT	SW	TG	ØTG1	U	U1	WH	ZG
63	40	15	68	68	G3/8	32	M16x1.5	20	183	20	21	M8	16	42.4	60	40	40	19	124
80	50	15	86	86	G3/8	41.5	M20x1.5	32	215	20	21	M6	27	49.5	70	35.5	35	26	139
100	40	25	104	104	G1/2	52	M20x1.5	25	306.5	28.5	33	M10	21	50	70.7	52	47.5	113	153.5

\*Other stroke lengths manufactured after prior technical consultation.

### ORDER NUMBER CONSTRUCTION

1

**10 . P02 H . 0100**

**Type**  
**10** - standard cylinder  
**11** - cylinder with magnet (BPST)  
 (only available in variety P02)

**Variety code**  
**P01** - cylinder with straight cover  
 (only for standard version,  
 diameter 63 mm)  
**P02** - with rounded cover

**Diameter code**  
**H** - 63 mm  
**J** - 80 mm  
**K** - 100 mm

**Stroke [mm]**  
 stroke e.g. 0100 = 100 mm

### ORDERING PROCEDURE

The order should include: name, nominal diameter, cylinder stroke, order number and the number of pieces, e.g.:

**Cylinder SPS D63 x 100 no. 10.P02H.0100 1 pc.**

	<b>ZS ZSS</b>	Rodless cylinders standard	page 1.14.03 1.14.05 1.14.09
	<b>ZK ZKS</b>	Rodless cylinders short	page 1.14.03 1.14.07 1.14.09
	<b>ZF ZFF ZFK ZFU ZFB</b>	Rodless cylinders with guides	page 1.14.03 1.14.15
	<b>ZP</b>	Rodless parallel cylinders	page 1.14.25
	<b>ZGS ZGK ZGF</b>	Rodless gripping cylinders	page 1.14.29
	<b>ZTS ZTK ZTF</b>	Rodless tandem cylinders	page 1.14.37
	<b>ZDS ZDK ZDF ZFK</b>	Rodless double-acting cylinders	page 1.14.41
	<b>ACCESSORIES</b>	Accessories for mounting multi-axis feed units, cross couplings, perpendicular couplings	page 1.14.49



# RODLESS CYLINDERS

## General information



### TECHNICAL SPECIFICATIONS

<b>Design:</b>	Rodless cylinders with a direct connection of the piston rod assembly and slide valve via tube channel. The cylinders can be equipped with external guides to increase their capacity of transferring large forces and torques. The cylinders are equipped with a magnet (BSPT) to work with piston position sensors.
<b>Standard stroke range:</b>	0–6000 mm*
<b>Operating position:</b>	Any
<b>Cylinder type:</b>	Double-acting cylinders with pneumatic cushioning in extreme positions
<b>Operating pressure:</b>	2–8 bar
<b>Operating temperature:</b>	from - 20°C to +80°C
<b>Operating medium:</b>	Compressed air filtered to 40 µm with oil or dry air, oil-free filtered to 10 µm
<b>Construction materials:</b>	
<b>Extruded profile:</b>	- aluminium
<b>Gaskets:</b>	- oil-resistant elastomers; plastics
<b>Pneumatic cushioning:</b>	Pneumatic cushioning in end positions adjustable from 0 to 100% by turning the adjustment screw by 90°

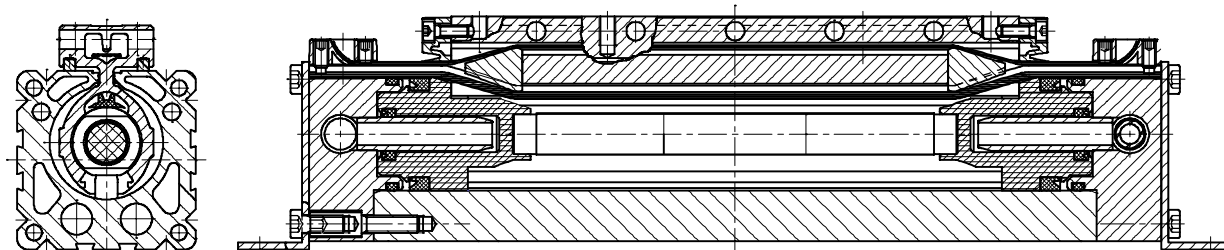

### DESIGN FEATURES

- The cylinders have a shaped tube made as an extruded aluminium profile with high rigidity
- The slide valve is equipped with external and front scrapers to prevent the ingress of contaminants
- Channels in the profile allow different types of accessories and position sensors to be fitted
- Mounting elements can be rotated by 90°
- Modern solution with cushioning needle
- Large surface area for mounting on the slide valve
- For long working stroke lengths, external slide valve guidance is possible
- Resistance to vibration
- Connections can be made from one side of the cylinder
- Possibility of transferring high forces and torques
- Guide mounting possible even after installation of the cylinder

Diameter D of the cylinder	Force / 6 bar	Pneumatic cushioning	Weight of cylinder in relation to stroke 0 mm					Weight increase / stroke
			ZS	ZK	ZF	ZFF	ZFK	
18	140 N	15 mm	0.3 kg	0.2 kg	0.4 kg	0.6 kg	0.3 kg	1.5 kg / 1000 mm
25	270 N	18 mm	0.6 kg	0.4 kg	0.9 kg	1.1 kg	0.6 kg	2.6 kg / 1000 mm
32	440 N	24 mm	1.1 kg	0.7 kg	1.5 kg	2.2 kg	1.2 kg	3.6 kg / 1000 mm
40	680 N	34 mm	1.8 kg	1.2 kg	2.8 kg	3.8 kg	2.0 kg	4.8 kg / 1000 mm
50	1060 N	40 mm	3.2 kg	2.0 kg	4.9 kg	6.4 kg	3.2 kg	7.4 kg / 1000 mm
63	1680 N	49 mm	5.6 kg	3.2 kg	8.0 kg	10.4 kg	6.4 kg	10.0 kg / 1000 mm

\*Other stroke lengths manufactured after prior technical consultation.

### ADDITIONAL INFORMATION FOR ZK TYPE SHORT CYLINDERS

- Base dimension (for 0 mm stroke) 42% shorter
- Reduced installation space compared to a standard piston rod cylinder
- Shorter installation dimensions
- Reduced costs due to compact design

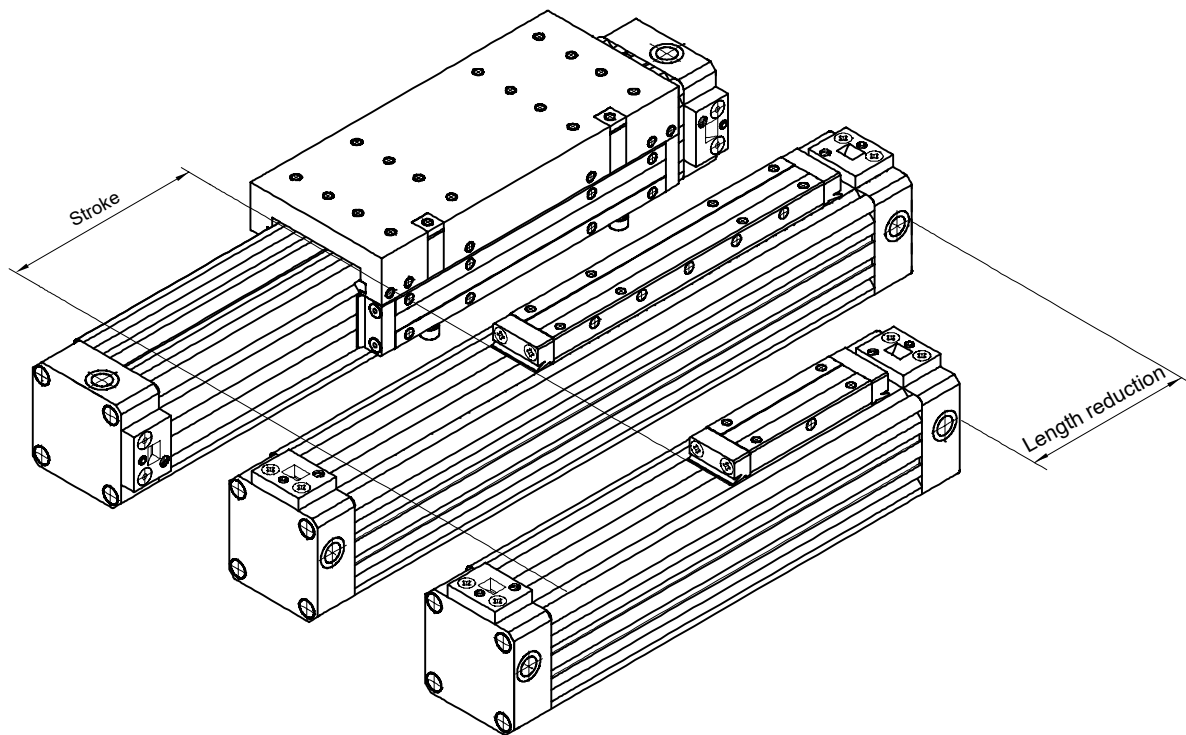

# RODLESS CYLINDERS

ZS, ZK, ZF type



## LOAD

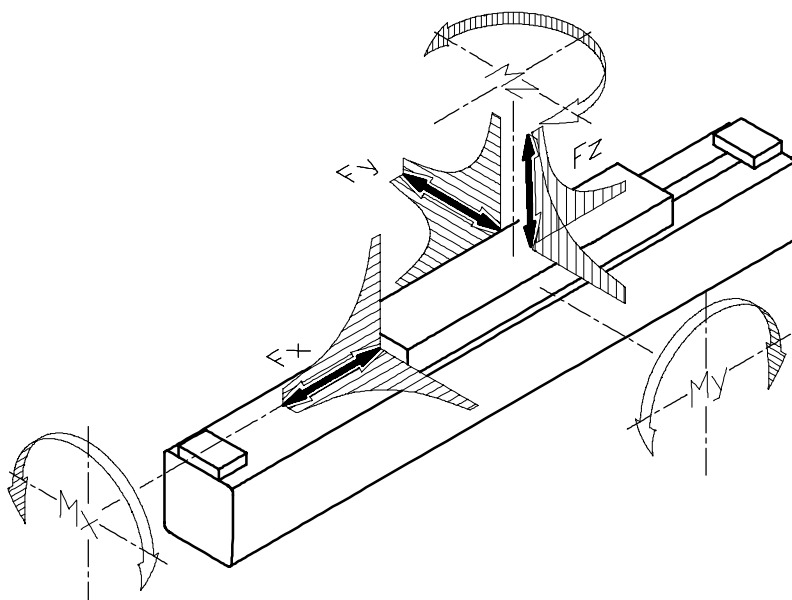

$$\sum F = F_{zul} = \sqrt{F_x^2 + F_y^2 + F_z^2}$$

### ZS type standard

Piston ∅	Vmax ≤ 0.35 m/s			Fzul. At speed v			Torques		
	Fx (N) Supply pressure 6 bar	Fy (N)	Fz (N)	Fzul. at 0.75 m/s	Fzul. at 1 m/s	Fzul. at 1.5 m/s	Mx (Nm) Fy/Fz	My (Nm) Fx/Fz	Mz (Nm) Fx/Fy
18	140	80	300	80	40	20	1	3	3
25	270	110	480	155	90	40	2	13	13
32	440	165	650	280	155	70	3.5	25	25
40	680	225	800	500	290	125	5.5	40	40
50	1060	325	1060	790	420	195	10	65	65
63	1680	435	1680	1500	850	370	16	100	100

### ZK type short version

Piston ∅	Vmax ≤ 0.35 m/s			Fzul. At speed v			Torques		
	Fx (N) Supply pressure 6 bar	Fy (N)	Fz (N)	Fzul. at 0.75 m/s	Fzul. at 1 m/s	Fzul. at 1.5 m/s	Mx (Nm) Fy/Fz	My (Nm) Fx/Fz	Mz (Nm) Fx/Fy
18	140	40	140	40	25	10	0.4	1.7	1.7
25	270	55	230	90	50	25	0.7	2.7	2.7
32	440	70	320	200	110	45	1	5	5
40	680	100	400	420	240	110	2	8.5	8.5
50	1060	140	480	750	440	190	3.5	13	13
63	1680	180	590	1500	850	380	5	18	8

### ZF type with guide

Piston ∅	Vmax ≤ 0.35 m/s			Fzul. At speed v			Torques		
	Fx (N) Supply pressure 6 bar	Fy (N)	Fz (N)	Fzul. at 0.75 m/s	Fzul. at 1 m/s	Fzul. at 1.5 m/s	Mx (Nm) Fy/Fz	My (Nm) Fx/Fz	Mz (Nm) Fx/Fy
18	140	370	370	100	58	26	3.5	6	6
25	270	800	800	280	160	65	10	20	20
32	440	1200	1200	510	300	140	25	45	45
40	680	1600	1600	1000	550	250	40	75	75
50	1060	2100	2100	1500	850	380	80	150	150
63	1680	2800	2800	2500	1400	610	110	250	250

NOTE: All force and torque values refer to V < 0.35 m/s. The use of higher speeds is limited by the given force values.

### LOAD

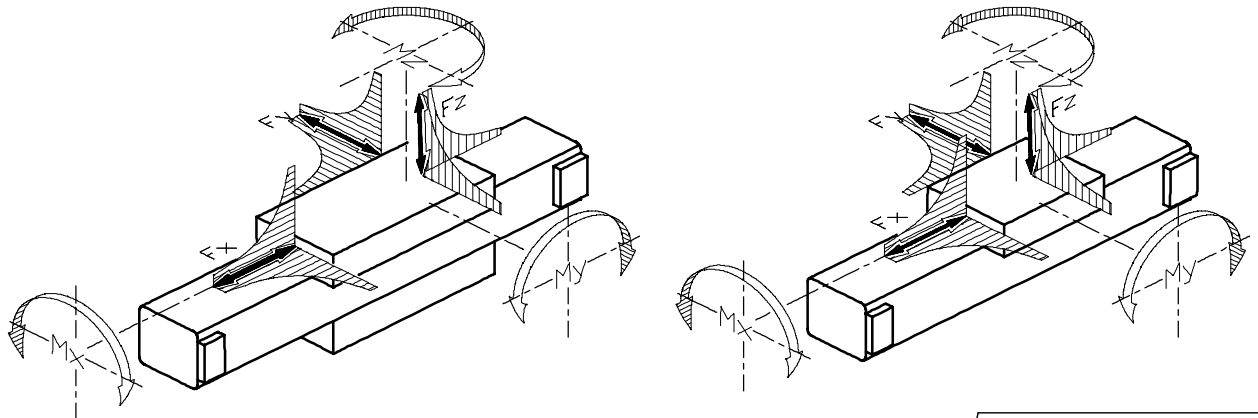

$$\sum F = F_{zul} = \sqrt{F_x^2 + F_y^2 + F_z^2}$$

### ZFF type with double guide

Piston	Vmax ≤ 0.35m/s			Fzul. At speed v			Torques		
	Fx (N) Supply pressure 6 bar	Fy (N)	Fz (N)	Fzul. at 0.75 m/s	Fzul. at 1 m/s	Fzul. at 1.5 m/s	Mx (Nm) Fy/Fz	My (Nm) Fx/Fz	Mz (Nm) Fx/Fy
18	140	550	550	150	80	31	5.2	9	9
25	270	1200	1200	420	210	80	15	30	30
32	440	1800	1800	750	400	170	37	67	67
40	680	2400	2400	1500	750	300	60	110	110
50	1060	3200	3200	2200	1150	460	120	220	220
63	1680	4200	4200	3700	1900	740	170	370	370

### ZFK type with short guide

Piston	Vmax ≤ 0.35m/s			Fzul. At speed v			Torques		
	Fx (N) Supply pressure 6 bar	Fy (N)	Fz (N)	Fzul. at 0.75 m/s	Fzul. at 1 m/s	Fzul. at 1.5 m/s	Mx (Nm) Fy/Fz	My (Nm) Fx/Fz	Mz (Nm) Fx/Fy
18	140	150	150	500	30	12	1.8	1.8	1.8
25	270	250	250	100	60	30	4	4	4
32	440	450	450	250	135	65	10	10	10
40	680	600	600	480	280	140	16	16	16
50	1060	900	900	800	480	220	30	30	30
63	1680	1100	1100	1500	950	400	45	45	45

NOTE: All force and torque values refer to V < 0.35 m/s. The use of higher speeds is limited by the given force values.

# RODLESS CYLINDERS

ZS type standard



## DIMENSIONS

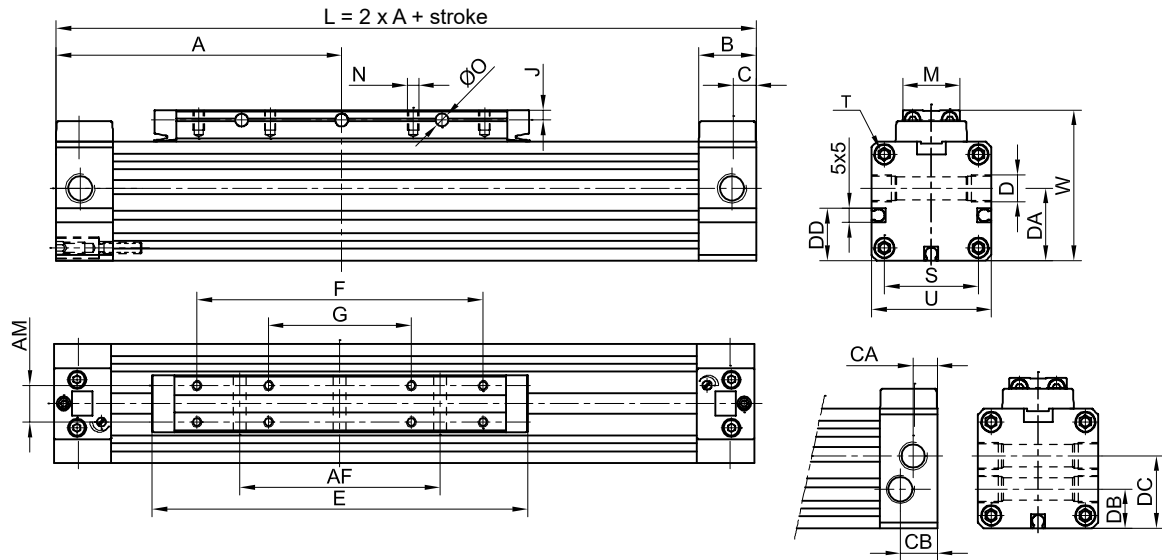

	Ø 18	Ø 25	Ø 32	Ø 40	Ø 50	Ø 63
<b>A</b>	80	100	120	150	180	215
<b>AF</b>	50	70	100	140	180	230
<b>AM</b>	10	13	16	22	29	40
<b>B</b>	16.5	20	20	23	23	29
<b>C</b>	6.5	8.5	8.5	13	13	13
<b>CA</b>	---	7	7	11	12	12.5
<b>CB</b>	---	13	13	14.5	14	15.5
<b>D</b>	M7x1 - 6	G1/8 - 8	G1/8 - 8	G1/4 - 12	G1/4 - 12	G3/8 - 12
<b>DA</b>	15.5	25.5	32	37.5	47.5	59.5
<b>DB</b>	---	14	16	18.5	22.5	24.5
<b>DC</b>	---	28	34.5	41	47.5	59.5
<b>DD</b>	---	18.5	21	29.5	37	44.5
<b>E</b>	103	131	171	220	280	333
<b>F</b>	75	100	140	180	220	280
<b>G</b>	---	50	70	90	110	140
<b>J</b>	3	3.5	4.5	5	6.5	8
<b>M</b>	15.5	20	25	33	42	54
<b>N</b>	M3 - 6	M4 - 7	M5 - 9	M6 - 10	M8 - 12.5	M8 - 15
<b>Ø O</b>	Ø 3.5	Ø 4.5	Ø 5.5	Ø 7	Ø 7	Ø 9
<b>□ S</b>	□ 23.5	□ 33	□ 41	□ 51	□ 63	□ 78
<b>T</b>	M3 - 7	M4 - 9	M5 - 10	M6 - 12	M8 - 12	M8 - 12
<b>□ U</b>	□ 30	□ 42	□ 52	□ 63	□ 78	□ 93
<b>W</b>	39	53	65	79	96	113.5

### ORDER NUMBER CONSTRUCTION

**11 . 500 D . 0100 ZS**

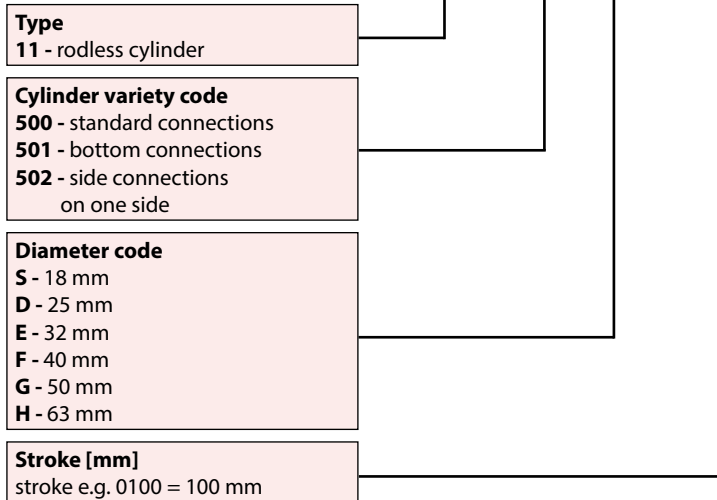

### ORDERING PROCEDURE

The order should include: name, nominal diameter, cylinder stroke, order number, connection type and the number of pieces, e.g.:

**Standard cylinder type ZS Ø25 stroke 100 mm no. 11.500D.0100ZS standard connection 1 pc.**

# RODLESS CYLINDERS

## ZK type short version



### DIMENSIONS

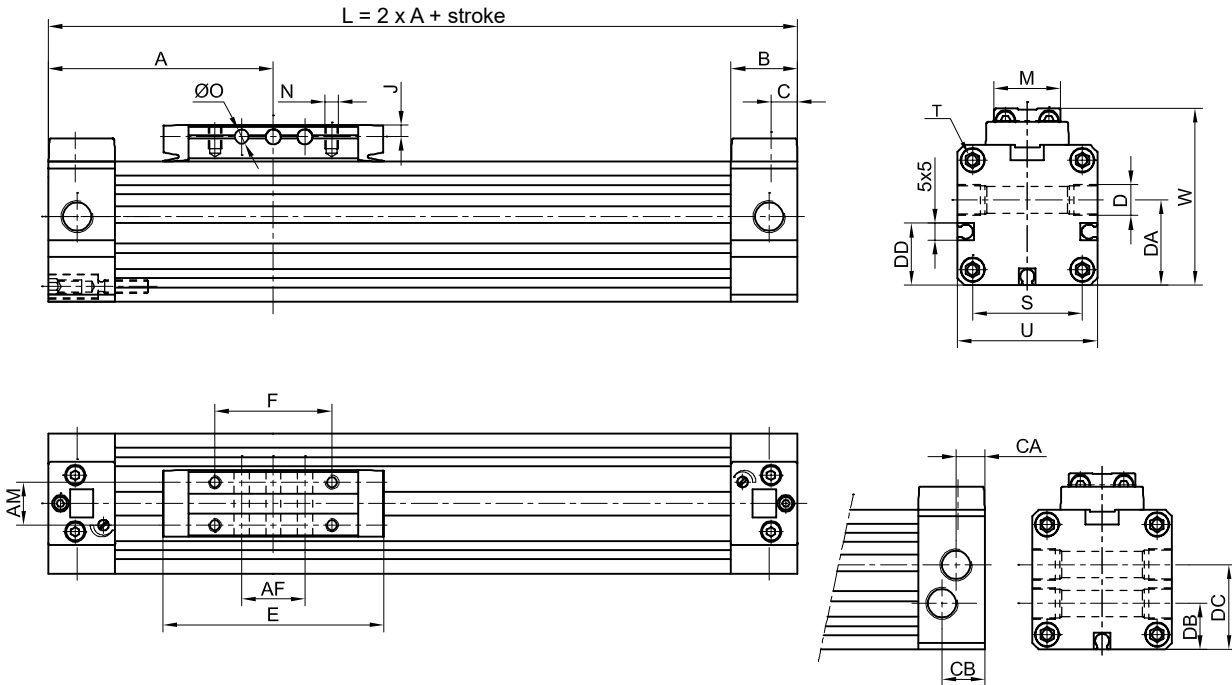

	Ø 18	Ø 25	Ø 32	Ø 40	Ø 50	Ø 63
<b>A</b>	57.5	67.5	77.5	95	105	125
<b>AF</b>	15	19	35	50	46	70
<b>AM</b>	10	13	16	22	29	40
<b>B</b>	16.5	20	20	24	24	30
<b>C</b>	6.5	8.5	8.5	13	13	13
<b>CA</b>	---	7	7	9.5	9.5	11
<b>CB</b>	---	13	13	14.5	14.5	18.5
<b>D</b>	M5x1 - 6	G1/8 - 8	G1/8 - 8	G1/4 - 12	G1/4 - 12	G3/8 - 12
<b>DA</b>	17.5	25.5	32	37.5	47.5	59.5
<b>DB</b>	---	14	17.5	20	26	30
<b>DC</b>	---	28	34.5	42	52	62
<b>DD</b>	---	18.5	21	29.5	37	44.5
<b>E</b>	58	66	86	110	130	153
<b>F</b>	30	35	55	70	70	100
<b>J</b>	3	3.5	4.5	5	6.5	8
<b>M</b>	15.5	20	25	33	42	54
<b>N</b>	M3 - 6	M4 - 7	M5 - 9	M6 - 10	M8 - 12.5	M8 - 15
<b>Ø O</b>	Ø 3.5	Ø 4.5	Ø 5.5	Ø 7	Ø 7	Ø 9
<b>□ S</b>	□ 23.5	□ 33	□ 41	□ 51	□ 63	□ 78
<b>T</b>	M3 - 7	M4 - 9	M5 - 10	M6 - 12	M8 - 12	M8 - 12
<b>□ U</b>	□ 30	□ 42	□ 52	□ 63	□ 78	□ 93
<b>W</b>	39	53	65	79	96	113.5

### ORDER NUMBER CONSTRUCTION

**11 . 500 D . 0100 ZK**

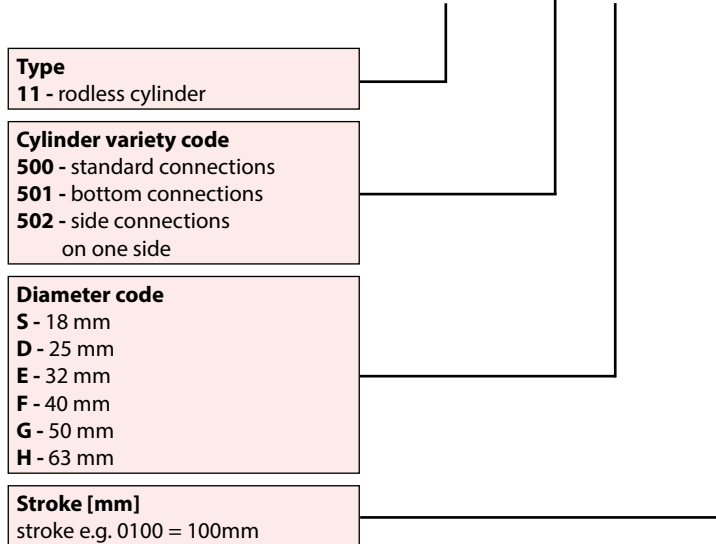

### ORDERING PROCEDURE

The order should include: name, nominal diameter, cylinder stroke, order number, connection type and the number of pieces, e.g.:

**Standard cylinder type ZK Ø25 short version with 100 mm stroke No. 11.500D.0100ZK  
Standard connections 1 pc.**



# RODLESS CYLINDERS

## ZSS / ZKS type with guides



### DESIGN FEATURES

- Cylinders ZSS and ZKS type are used to carry heavy working loads
- The guide unit, mounted outside the cylinder, allows for the transfer of large torques and loads
- Max. working strokes - 1500 mm, other stroke lengths can be manufactured on request
- Cylinders ZSS type with two guides have the same overall length as standard cylinders type ZS
- ZKS type cylinders are equipped with a guide trolley

Diameter D of the cylinder	Force / 6 bar	Weight of cylinder in relation to stroke 0 mm		Weight increase / stroke
		ZSS	ZKS	
18	140 N	1 kg	0.8 kg	2.5 kg / 1000 mm
25	270 N	1.6 kg	1.4 kg	4 kg / 1000 mm
32	440 N	2.5 kg	2.2 kg	5.8 kg / 1000 mm
40	680 N	3.8 kg	3.2 kg	8.3 kg / 1000 mm
50	1060 N	5.9 kg	5.6 kg	12.1 kg / 1000 mm
63	1680 N	9 kg	8.5 kg	15.5 kg / 1000 mm

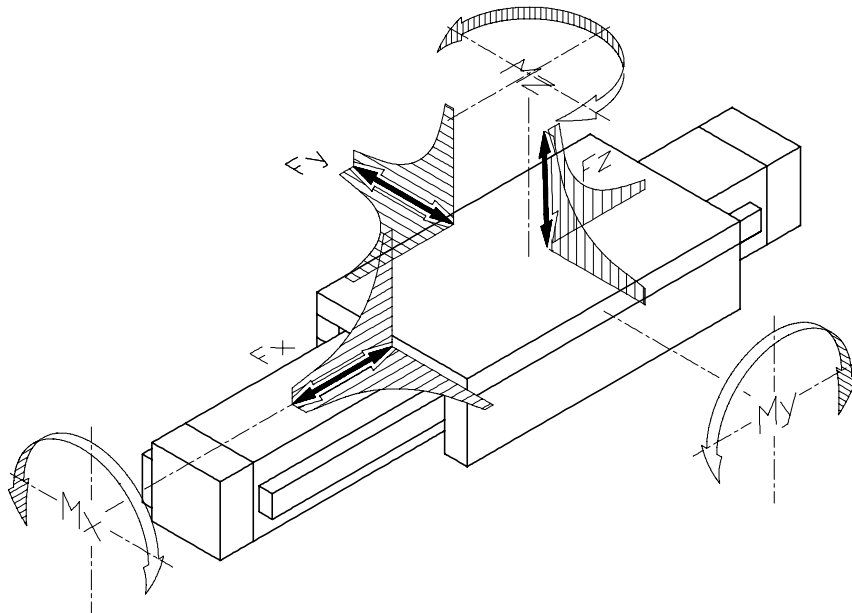

### ZSS type standard

Piston Ø	Carriage Type	C <sub>dyn</sub> (N)	C <sub>0</sub> (N)	Rail type	Torques		
					Mx (Nm)	My (Nm)	Mz (Nm)
18	MR15MN	3810	5590	MR15M	87	22	22
25	LAS15ALZ	8350	16300	L1S15	170	154	130
32	LAS20ALZ	11700	23500	L1S20	320	266	222
40	LAS25ALZ	18800	36500	L1S25	572	516	434
50	LAS30ALZ	28800	55000	L1S30	1040	870	730
63							

### ZKS type short version

Piston Ø	Carriage Type	C <sub>dyn</sub> (N)	C <sub>0</sub> (N)	Rail type	Torques		
					Mx (Nm)	My (Nm)	Mz (Nm)
18	MR15MN	3810	5590	MR15M	43	11	11
25	LAS15ALZ	8350	16300	L1S15	85	77	65
32	LAS20ALZ	11700	23500	L1S20	160	133	111
40	LAS25ALZ	18800	36500	L1S25	286	258	217
50	LAS30ALZ	28800	55000	L1S30	520	435	365
63							

### DIMENSIONS

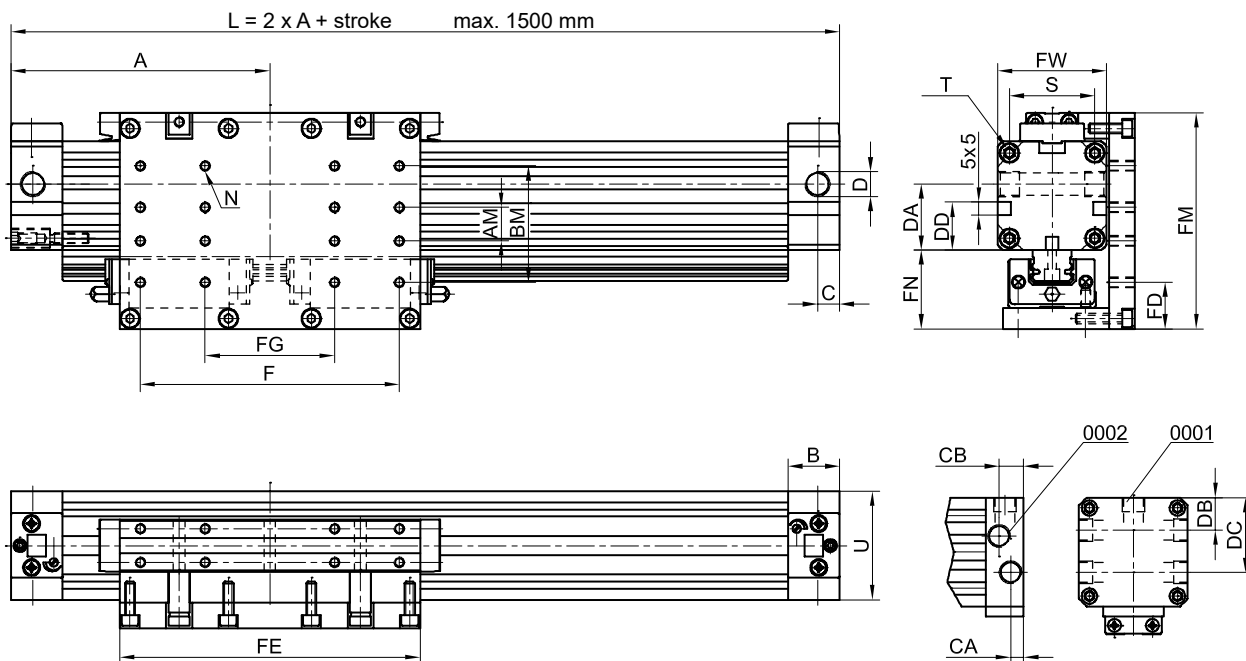

	Ø 18	Ø 25	Ø 32	Ø 40	Ø 50	Ø 63
<b>A</b>	80	100	120	150	180	215
<b>AM</b>	10	13	16	22	29	40
<b>B</b>	16.5	20	20	24	24	30
<b>BM</b>	35	45	55	70	85	105
<b>C</b>	6.5	8.5	8.5	13	13	13
<b>CA</b>	---	7	7	9.5	9.5	11
<b>CB</b>	---	13	13	14.5	14.5	18.5
<b>D</b>	M7x1 - 6	G1/8 - 8	G1/8 - 8	G1/4 - 12	G1/4 - 12	G3/8 - 12
<b>DA</b>	15.5	25.5	32	37.5	47.5	59.5
<b>DB</b>	---	14	17.5	20	26	30
<b>DC</b>	---	28	34.5	42	52	62
<b>DD</b>	---	18.5	21	29.5	37	44.5
<b>F</b>	75	100	140	180	200	280
<b>FE</b>	90	116	156	220	260	313
<b>FG</b>	---	50	70	90	110	140
<b>FM</b>	60.5	83.5	101	120	151	168.5
<b>FN</b>	20.5	30.5	36	41	55	55
<b>FO</b>	13	18	22	25	33	32
<b>FW</b>	39	53	65	79	96	113.5
<b>N</b>	M4 - 8	M4 - 8	M5 - 10	M6 - 12	M8 - 16	M8 - 16
<b>□ S</b>	□ 23.5	□ 33	□ 41	□ 51	□ 63	□ 78
<b>T</b>	M3 - 7	M4 - 9	M5 - 10	M6 - 12	M8 - 12	M8 - 12
<b>□ U</b>	□ 30	□ 42	□ 52	□ 63	□ 78	□ 93

# RODLESS CYLINDERS

## ZSS type with guides standard version



### ORDER NUMBER CONSTRUCTION

1

**11 . 510 D . 0100 ZSS**

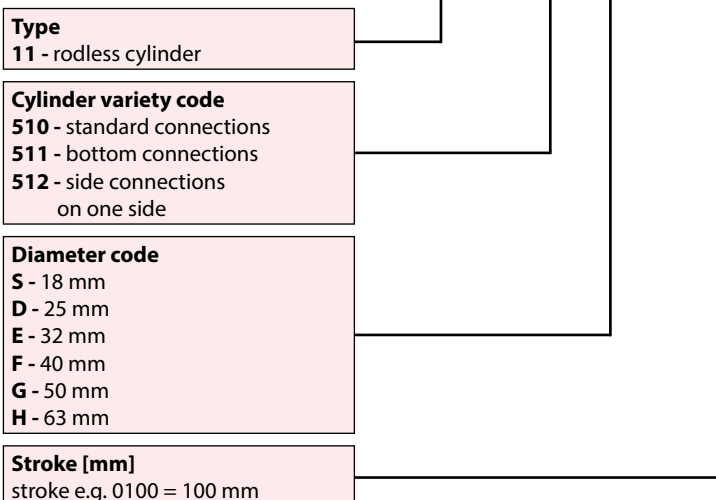

### ORDERING PROCEDURE

The order should include: name, nominal diameter, cylinder stroke, order number, connection type and the number of pieces, e.g.:

**Cylinder with standard guides, ZSS type Ø25 stroke 100 mm no. 11.510D.0100ZSS  
Standard connections 1 pc.**

### DIMENSIONS

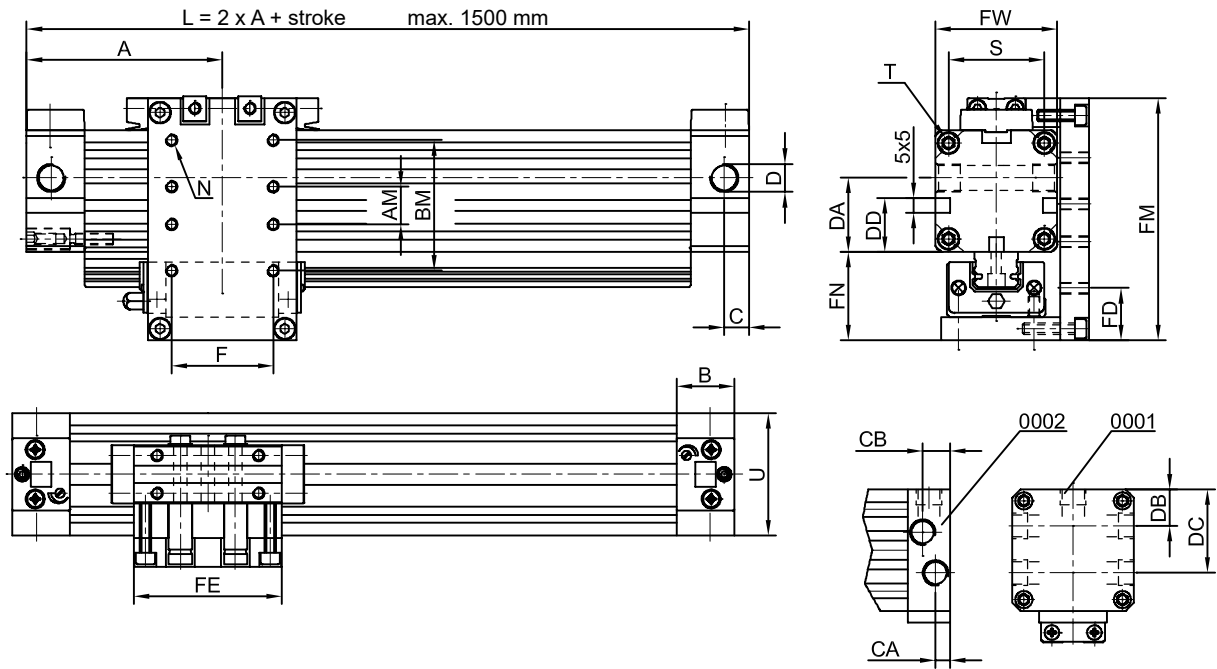

	Ø 18	Ø 25	Ø 32	Ø 40	Ø 50	Ø 63
<b>A</b>	80	100	120	150	180	215
<b>AM</b>	10	13	16	22	29	40
<b>B</b>	16.5	20	20	23	23	29
<b>BM</b>	35	45	55	70	85	105
<b>C</b>	6.5	8.5	8.5	13	13	13
<b>CA</b>	---	7	7	9.5	9.5	11
<b>CB</b>	---	13	13	14.5	14.5	18.5
<b>D</b>	M7x1 1/6	G1/8 - 8	G1/8 - 8	G1/4 - 12	G1/4 - 12	G3/8 - 12
<b>DA</b>	15.5	25.5	32	37.5	47.5	59.5
<b>DB</b>	---	14	17.5	20	26	30
<b>DC</b>	---	28	34.5	42	52	62
<b>DD</b>	---	18.5	21	29.5	37	44.5
<b>FE</b>	45	51	71	90	110	133
<b>F</b>	30	35	55	70	70	100
<b>FM</b>	60.5	83.5	101	120	151	168.5
<b>FN</b>	20.5	30.5	36	41	55	55
<b>FO</b>	13	18	22	25	33	32
<b>FW</b>	39	53	65	79	96	113.5
<b>N</b>	M4 - 8	M4 - 8	M5 - 10	M6 - 12	M8 - 16	M8 - 16
<input type="checkbox"/> <b>S</b>	<input type="checkbox"/> 23.5	<input type="checkbox"/> 33	<input type="checkbox"/> 41	<input type="checkbox"/> 51	<input type="checkbox"/> 63	<input type="checkbox"/> 78
<b>T</b>	M3 - 7	M4 - 9	M5 - 10	M6 - 12	M8 - 12	M8 - 12
<input type="checkbox"/> <b>U</b>	<input type="checkbox"/> 30	<input type="checkbox"/> 42	<input type="checkbox"/> 52	<input type="checkbox"/> 63	<input type="checkbox"/> 78	<input type="checkbox"/> 93

# RODLESS CYLINDERS

## ZKS type with guide short version



### ORDER NUMBER CONSTRUCTION

1

**11 . 510 D . 0100 ZKS**

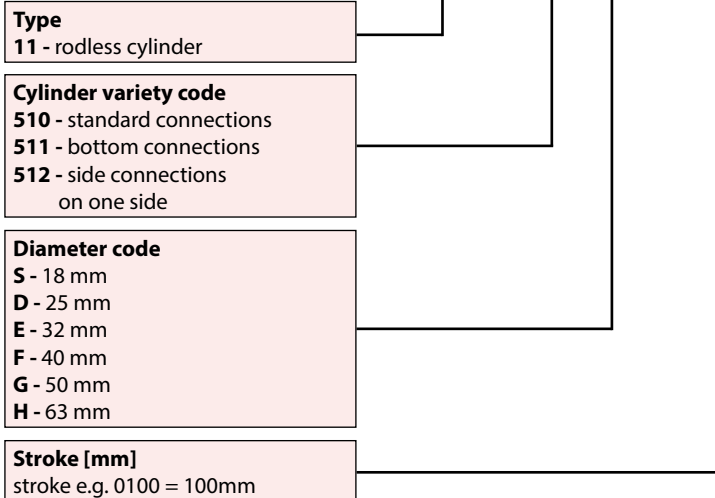

### ORDERING PROCEDURE

The order should include: name, nominal diameter, cylinder stroke, order number, connection type and the number of pieces, e.g.:

**Cylinder with guide ZKS type  $\varnothing$ 25 stroke 100 mm no. 11.510D.0100ZKS  
Standard connections 1 pc.**

### DIMENSIONS

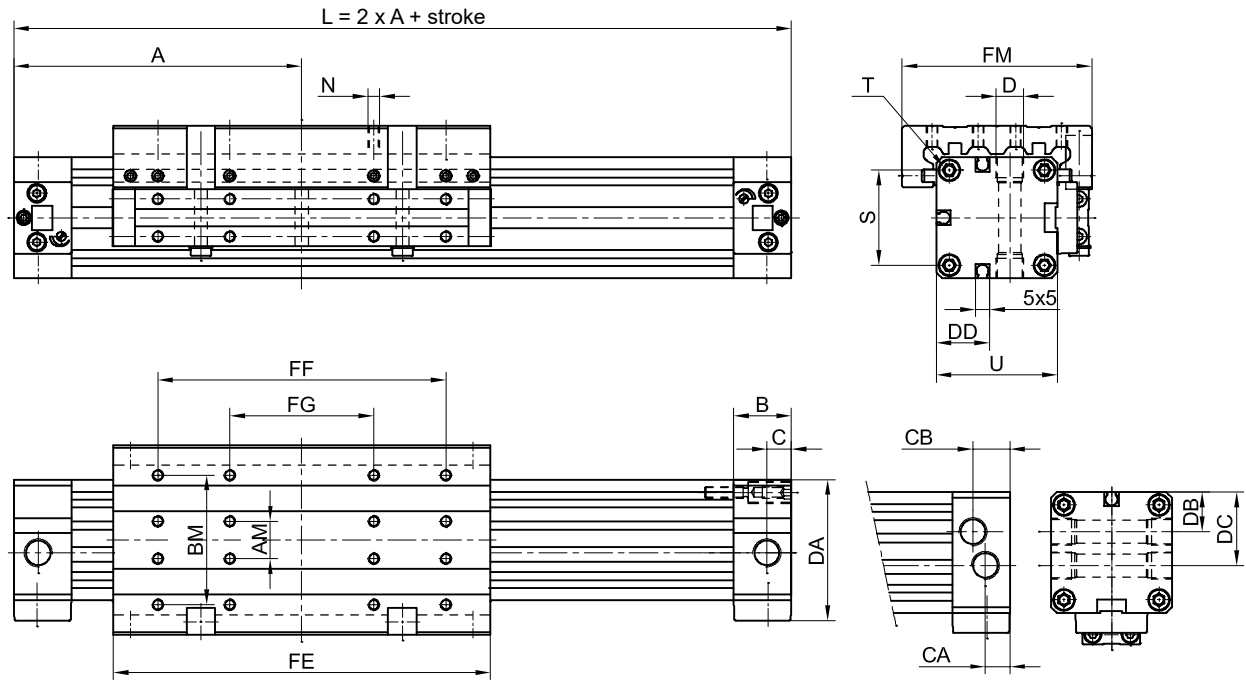

	Ø 18	Ø 25	Ø 32	Ø 40	Ø 50	Ø 63
<b>A</b>	80	100	120	150	180	215
<b>AM</b>	10	13	16	22	29	40
<b>B</b>	16.5	20	20	24	23	30
<b>BM</b>	35	45	55	70	85	105
<b>C</b>	6.5	8.5	8.5	13	13	13
<b>CA</b>	---	7	7	9.5	9.5	11
<b>CB</b>	---	13	13	14.5	14.5	18.5
<b>D</b>	M7x1 - 6	G1/8 - 8	G1/8 - 8	G1/4 - 12	G1/4 - 12	G3/8 - 12
<b>DA</b>	17.5	25.5	32	37.5	47.5	59.5
<b>DB</b>	---	14	17.5	20	26	30
<b>DC</b>	---	28	34.5	42	52	62
<b>DD</b>	---	18.5	21	29.5	37	44.5
<b>FE</b>	103	131	171	220	280	333
<b>FF</b>	75	100	140	180	220	280
<b>FG</b>	---	50	70	90	110	140
<b>FM</b>	50	66	80	97	116	136
<b>FW</b>	39	53	65	79	96	113.5
<b>N</b>	M4 - 8	M4 - 8	M5 - 10	M6 - 12	M8 - 16	M8 - 16
<b>□ S</b>	□ 23.5	□ 33	□ 41	□ 51	□ 63	□ 78
<b>T</b>	M3 - 7	M4 - 9	M5 - 10	M6 - 12	M8 - 12	M8 - 12
<b>□ U</b>	□ 30	□ 42	□ 52	□ 63	□ 78	□ 93

# RODLESS CYLINDERS

ZF type with guide



## ORDER NUMBER CONSTRUCTION

1

**11 . 510 D . 0100 ZF**

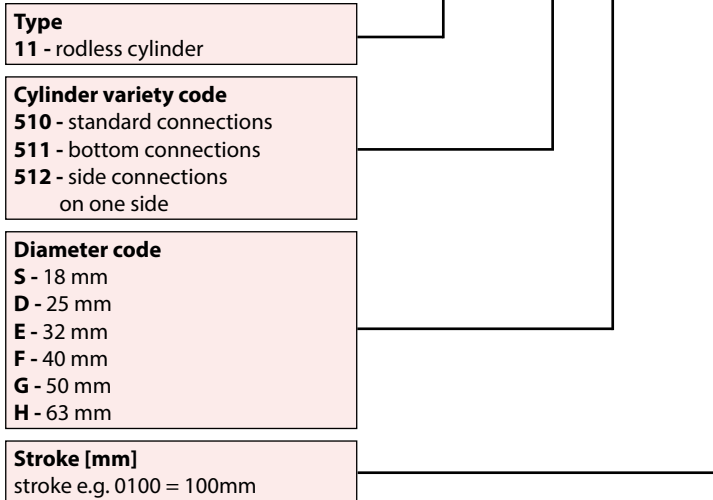

## ORDERING PROCEDURE

The order should include: name, nominal diameter, cylinder stroke, order number, connection type and the number of pieces, e.g.:

**Cylinder with guide ZF type Ø25 stroke 100 mm no. 11.510D.0100ZF  
Standard connections 1 pc.**

### DIMENSIONS

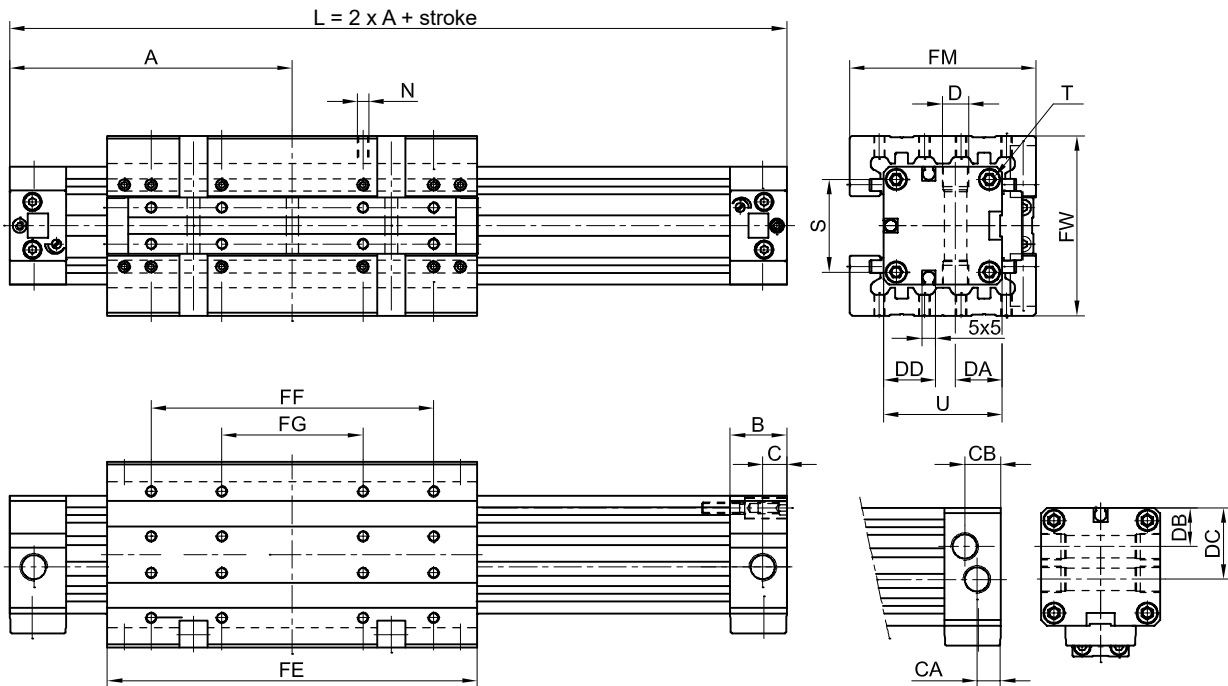

	Ø 18	Ø 25	Ø 32	Ø 40	Ø 50	Ø 63
<b>A</b>	80	100	120	150	180	215
<b>AM</b>	10	13	16	22	29	40
<b>B</b>	16.5	20	20	24	23	30
<b>BM</b>	35	45	55	70	85	105
<b>C</b>	6.5	8.5	8.5	13	13	13
<b>CA</b>	---	7	7	9.5	9.5	11
<b>CB</b>	---	13	13	14.5	14.5	18.5
<b>D</b>	M7x1 - 6	G1/8 - 8	G1/8 - 8	G1/4 - 12	G1/4 - 12	G3/8 - 12
<b>DA</b>	17.5	25.5	32	37.5	47.5	59.5
<b>DB</b>	---	14	17.5	20	26	30
<b>DC</b>	---	28	34.5	42	52	62
<b>DD</b>	---	18.5	21	29.5	37	44.5
<b>FE</b>	103	131	171	220	280	333
<b>FF</b>	75	100	140	180	220	280
<b>FG</b>	---	50	70	90	110	140
<b>FM</b>	50	66	80	97	116	136
<b>FW</b>	48	64	78	95	114	134
<b>N</b>	M4 - 8	M4 - 8	M5 - 10	M6 - 12	M8 - 16	M8 - 16
<input type="checkbox"/> <b>S</b>	<input type="checkbox"/> 23.5	<input type="checkbox"/> 33	<input type="checkbox"/> 41	<input type="checkbox"/> 51	<input type="checkbox"/> 63	<input type="checkbox"/> 78
<b>T</b>	M3 - 7	M4 - 9	M5 - 10	M6 - 12	M8 - 12	M8 - 12
<input type="checkbox"/> <b>U</b>	<input type="checkbox"/> 30	<input type="checkbox"/> 42	<input type="checkbox"/> 52	<input type="checkbox"/> 63	<input type="checkbox"/> 78	<input type="checkbox"/> 93



# RODLESS CYLINDERS

## ZFF type with guide



### ORDER NUMBER CONSTRUCTION

**11 . 510 D . 0100 ZFF**

**Type**  
11 - rodless cylinder

**Cylinder variety code**  
510 - standard connections  
511 - bottom connections  
512 - side connections  
on one side

**Diameter code**  
S - 18 mm  
D - 25 mm  
E - 32 mm  
F - 40 mm  
G - 50 mm  
H - 63 mm

**Stroke [mm]**  
stroke e.g. 0100 = 100mm

### ORDERING PROCEDURE

The order should include: name, nominal diameter, cylinder stroke, order number, connection type and the number of pieces, e.g.:

**Cylinder with guide type ZFF Ø25 stroke 100 mm no. 11.510D.0100ZFF  
Standard connections 1 pc.**

### DIMENSIONS

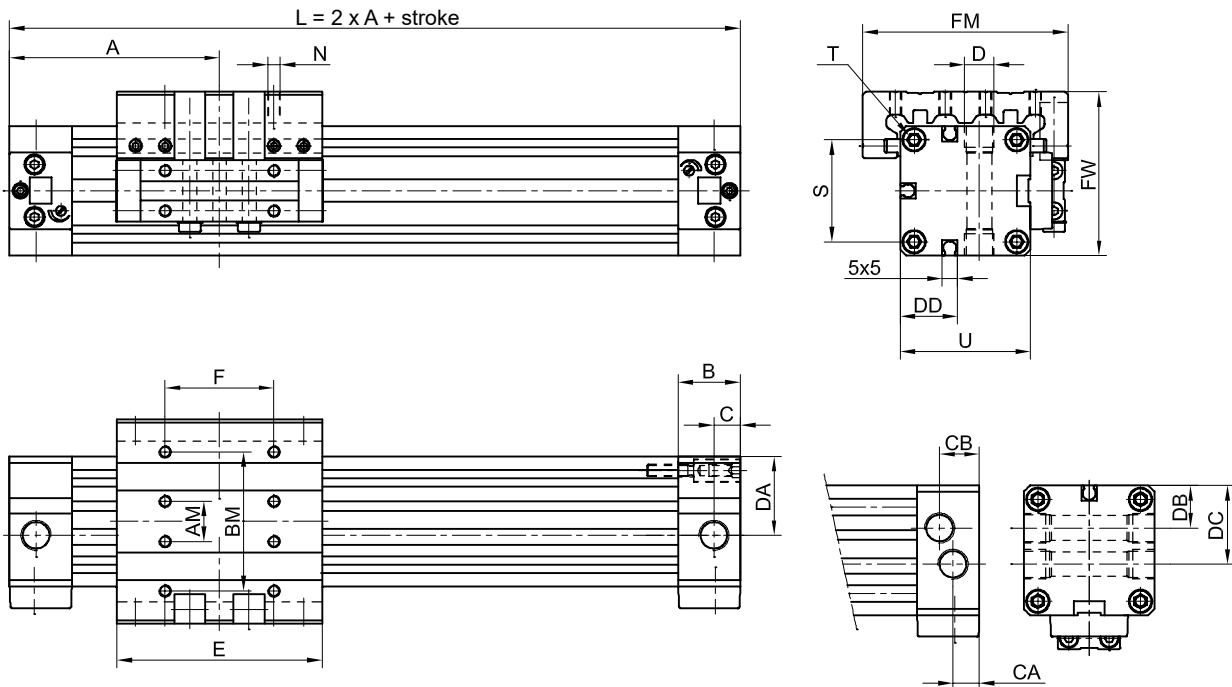

	Ø 18	Ø 25	Ø 32	Ø 40	Ø 50	Ø 63
<b>A</b>	57.5	67.5	77.5	95	105	125
<b>AM</b>	10	13	16	22	29	40
<b>B</b>	16.5	20	20	24	24	30
<b>BM</b>	35	45	55	70	85	105
<b>C</b>	6.5	8.5	8.5	13	13	13
<b>CA</b>	---	7	7	9.5	9.5	11
<b>CB</b>	---	13	13	14.5	14.5	18.5
<b>D</b>	M7x1 - 6	G1/8 - 8	G1/8 - 8	G1/4 - 12	G1/4 - 12	G3/8 - 12.5
<b>DA</b>	17.5	25.5	32	37.5	47.5	59.5
<b>DB</b>	---	14	17.5	20	26	30
<b>DC</b>	---	28	34.5	42	52	62
<b>DD</b>	15	21	26	31.5	39	46.5
<b>E</b>	58	66	86	110	130	153
<b>F</b>	30	35	55	70	70	100
<b>FM</b>	50	66	80	97	116	136
<b>FW</b>	39	53	65	79	96	113.5
<b>N</b>	M4 - 7.5	M4 - 8	M5 - 10	M6 - 12	M8 - 16	M8 - 16
<b>S</b>	□ 23.5	□ 33	□ 41	□ 51	□ 63	□ 78
<b>T</b>	M3 - 7	M4 - 9	M5 - 10	M6 - 12	M8 - 12	M8 - 12
<b>U</b>	□ 30	□ 42	□ 52	□ 63	□ 78	□ 93

# RODLESS CYLINDERS

ZFK type with guide



## ORDER NUMBER CONSTRUCTION

1

**11 . 510 D . 0100 ZFK**

**Type**  
11 - rodless cylinder

**Cylinder variety code**  
510 - standard connections  
511 - bottom connections  
512 - side connections  
on one side

**Diameter code**  
S - 18 mm  
D - 25 mm  
E - 32 mm  
F - 40 mm  
G - 50 mm  
H - 63 mm

**Stroke [mm]**  
stroke e.g. 0100 = 100mm

## ORDERING PROCEDURE

The order should include: name, nominal diameter, cylinder stroke, order number, connection type and the number of pieces, e.g.:

**Cylinder with guide ZFK type Ø25 stroke 100 mm no. 11.510D.0100ZFK  
Standard connections 1 pc.**

### DIMENSIONS

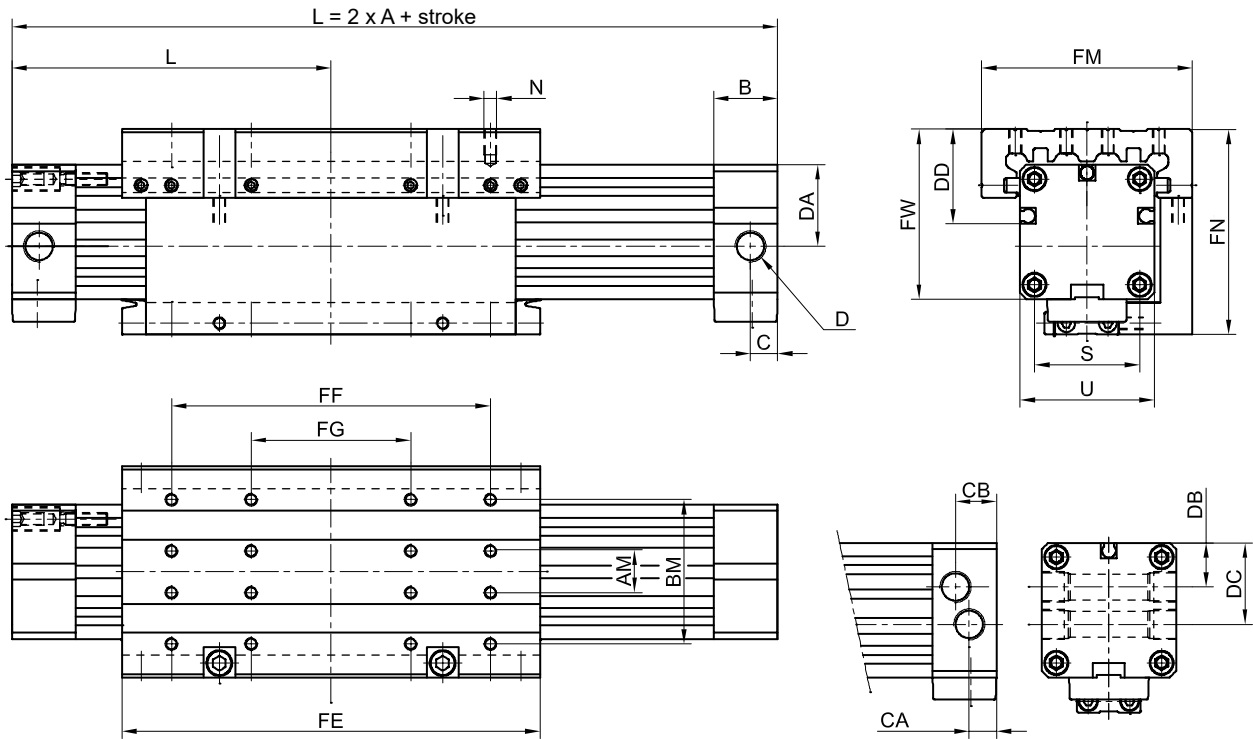

	Ø 18	Ø 25	Ø 32	Ø 40	Ø 50	Ø 63
<b>A</b>	80	100	120	150	180	215
<b>AM</b>	10	13	16	22	29	40
<b>B</b>	16.5	20	20	24	24	30
<b>BM</b>	35	45	55	70	85	105
<b>C</b>	6.5	8.5	8.5	13	13	13
<b>CA</b>	---	7	7	9.5	9.5	11
<b>CB</b>	---	13	13	14.5	14.5	18.5
<b>D</b>	M7x1 - 6	G1/8 - 8	G1/8 - 8	G1/4 - 12	G1/4 - 12	G3/8 - 12
<b>DA</b>	17.5	25.5	32	37.5	47.5	59.5
<b>DB</b>	---	14	17.5	20	26	30
<b>DC</b>	---	28	34.5	42	52	62
<b>DD</b>	---	18.5	21	29.5	37	44.5
<b>FE</b>	103	131	171	220	280	333
<b>FF</b>	75	100	140	180	220	280
<b>FG</b>	---	50	70	90	110	140
<b>FN</b>	48	64	78	95	114	134
<b>FM</b>	50	66	80	97	116	136
<b>FW</b>	39	53	65	79	96	113.5
<b>N</b>	M4 - 7.5	M4 - 8	M5 - 10	M6 - 12	M8 - 16	M8 - 16
<input type="checkbox"/> <b>S</b>	<input type="checkbox"/> 23.5	<input type="checkbox"/> 33	<input type="checkbox"/> 41	<input type="checkbox"/> 51	<input type="checkbox"/> 63	<input type="checkbox"/> 78
<b>T</b>	M3 - 7	M4 - 9	M5 - 10	M6 - 12	M8 - 12	M8 - 12
<input type="checkbox"/> <b>U</b>	<input type="checkbox"/> 30	<input type="checkbox"/> 42	<input type="checkbox"/> 52	<input type="checkbox"/> 63	<input type="checkbox"/> 78	<input type="checkbox"/> 93

# RODLESS CYLINDERS

ZFU type with guide



## ORDER NUMBER CONSTRUCTION

1

**11 . 510 D . 0100 ZFU**

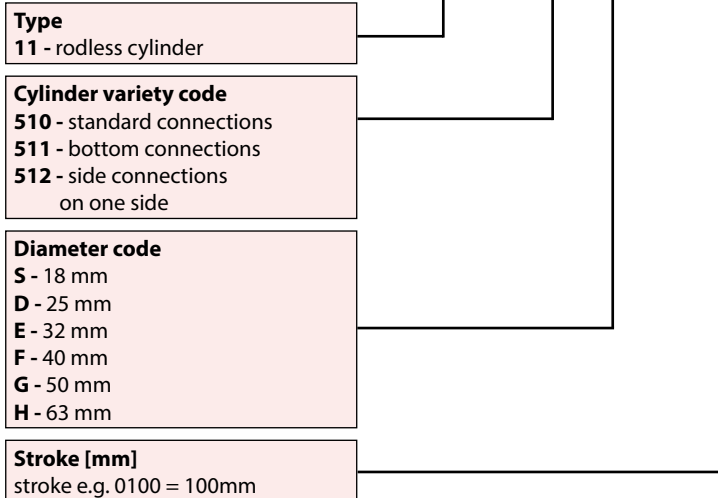

## ORDERING PROCEDURE

The order should include: name, nominal diameter, cylinder stroke, order number, connection type and the number of pieces, e.g.:

**Cylinder with guide type ZFU Ø25 stroke 100 mm no. 11.510D.0100ZFU  
Standard connections 1 pc.**

### DESIGN FEATURES

- The cylinders use proven technical solutions
- The stopping force of the slide valve is greater than the force of the cylinder
- The cylinders have an external slide valve guide
- The unit can be mounted on a standard cylinder after purchase and installation
- Easy to assemble and install
- Small overall dimensions
- Max. working strokes: 2500 mm
- An additional distribution valve is required to control the lock (as shown in the diagram)

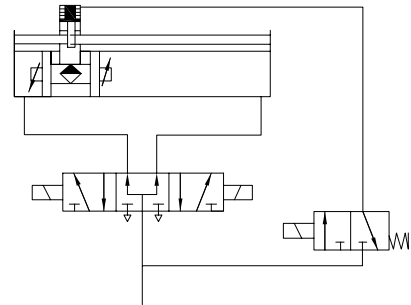

### DIMENSIONS

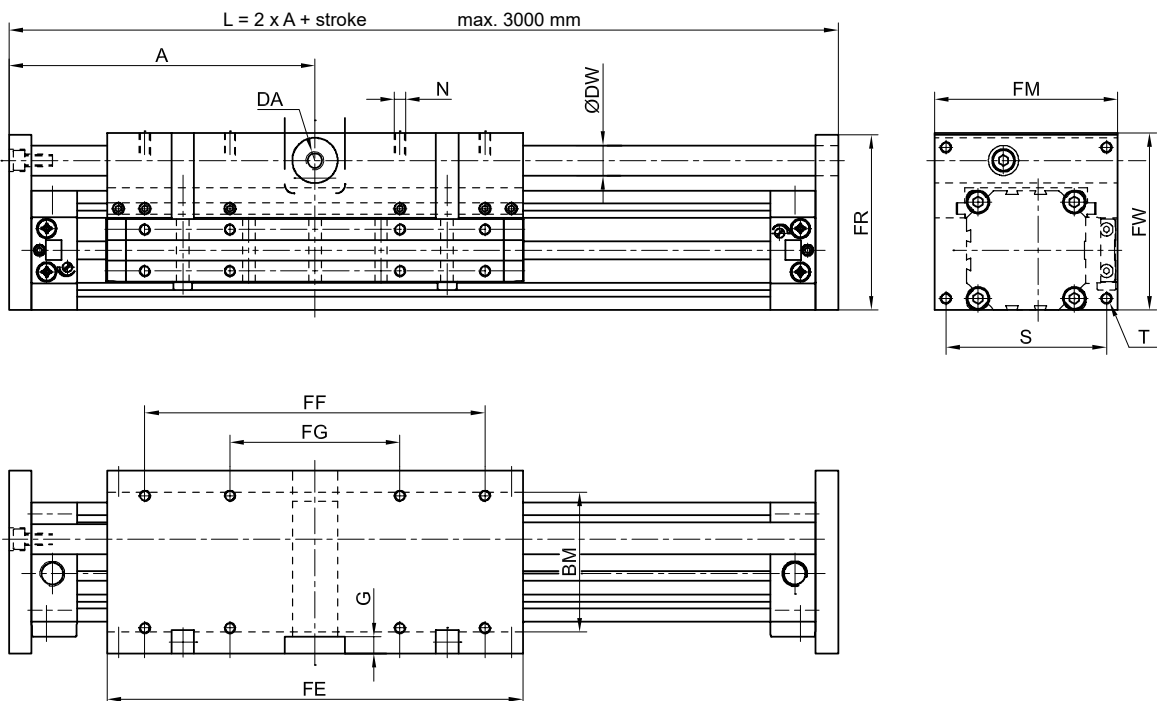

	Ø 18	Ø 25	Ø 32	Ø 40	Ø 50	Ø 63
<b>A</b>	86	100	130	162	195	230
<b>BM</b>	35	45	55	70	85	105
<b>D</b>	M5 - 5.5	G1/8 - 7.7	G1/8 - 7.7	G1/4 - 11.7	G1/4 - 11.7	G3/8 - 11.7
<b>DA</b>	M5	M5	M5	G1/8	G1/8	G1/8
<b>DW</b>	Ø 6	Ø 12	Ø 12	Ø 16	Ø 20	Ø 20
<b>FE</b>	103	131	171	220	280	333
<b>FF</b>	75	100	140	180	220	280
<b>FG</b>	---	50	70	90	110	140
<b>FM</b>	50	66	80	97	116	136
<b>FW</b>	48	67	79	93.5	115	139
<b>FR</b>	47	66	78	92.5	115	138
<b>G</b>	6	---	5	---	---	---
<b>N</b>	M4 - 7.5	M4 - 8	M5 - 10	M6 - 12	M8 - 16	M8 - 16
<b>□ S</b>	□ 42	□ 54	□ 68	□ 80	□ 100	□ 120
<b>T</b>	M3	M4	M5	M6	M8	M8
<b>□ U</b>	□ 6	□ 10	□ 10	□ 12	□ 15	□ 15
<b>Force FB</b>	180N	600N	600N	1000N	1400N	2200N

# RODLESS CYLINDERS

ZFB type with safety lock



## ORDER NUMBER CONSTRUCTION

1

**11 . 530 D . 0100 ZFB**

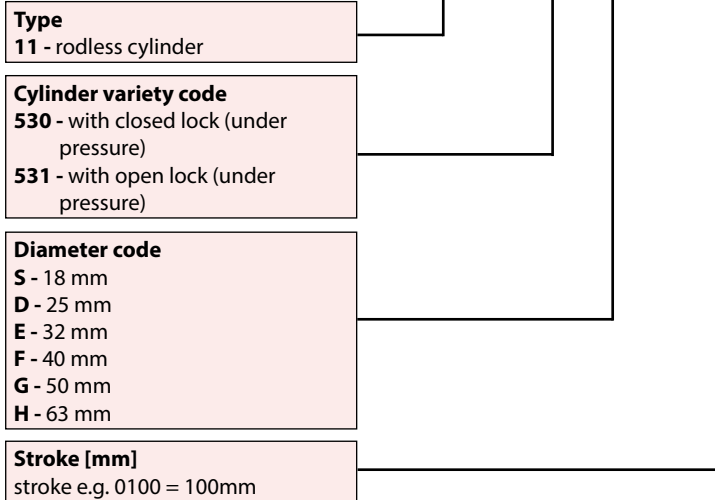

## ORDERING PROCEDURE

The order should include: name, nominal diameter, cylinder stroke, order number and the number of pieces, e.g.:

**Rodless cylinder type ZFB Ø25 stroke 100 mm, lock closed (under pressure)  
no. 11.530D.0100ZFB 1 pc**

### DESIGN FEATURES

- Parallel cylinder with centrally located air connection is designed to handle heavy working loads
- Cylinder load can be multiplied
- Working force is doubled
- Parallel cylinders are used to move large elements, e.g. in the following applications:
  - drives in assembly systems and machines
  - drives in transport systems
  - different working strokes are available
- Handling of workpieces to be processed in machining centres
- The supply connections can be located in different positions
- The cylinders are equipped with pneumatic cushioning at the end of the stroke.

Diameter D of the cylinder	Force / 6 bar	Pneumatic cushioning	Weight of cylinder in relation to stroke 0 mm	Weight increase / stroke
25	540 N	18 mm	1.2 kg	5.2 kg / 1000 mm
32	880 N	24 mm	2.6 kg	7.2 kg / 1000 mm
40	1360 N	34 mm	4.6 kg	9.8 kg / 1000 mm
50	2120 N	40 mm	8.2 kg	15 kg / 1000 mm
63	3360 N	49 mm	13.6 kg	20 kg / 1000 mm

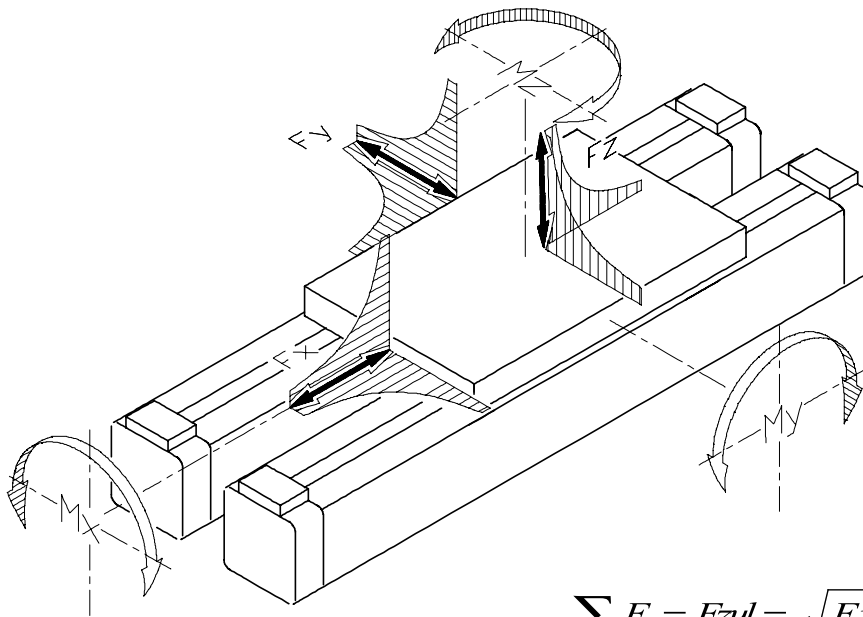

$$\sum F = F_{zul} = \sqrt{F_x^2 + F_y^2 + F_z^2}$$

### LOADS

Piston	Vmax ≤ 0.35m/s			Fzul. At speed v			Torques		
	Fx (N)	Fy (N)	Fz (N)	Fzul.	Fzul.	Fzul.	Mx (N)	My (N)	Mz (N)
∅	Supply pressure 6 bar			at 0.75 m/s	at 1 m/s	at 1.5 m/s	Fy/Fz	Fx/Fz	Fx/Fy
25	540	240	900	300	175	75	16	27	27
32	580	360	1220	540	300	130	29	52	52
40	1360	540	1750	1090	620	280	55	88	88
50	2120	750	2500	1760	1000	450	90	155	155
63	3360	1000	3300	2900	1660	720	148	260	260

NOTE: All force and torque values refer to  $v < 0.35$  m/s. Compliance with the following parameters guarantees a longer service life, minimum noise level and optimal working parameters. Higher speeds limit the given force values.



# RODLESS CYLINDERS

## ZP type parallel



### DIMENSIONS

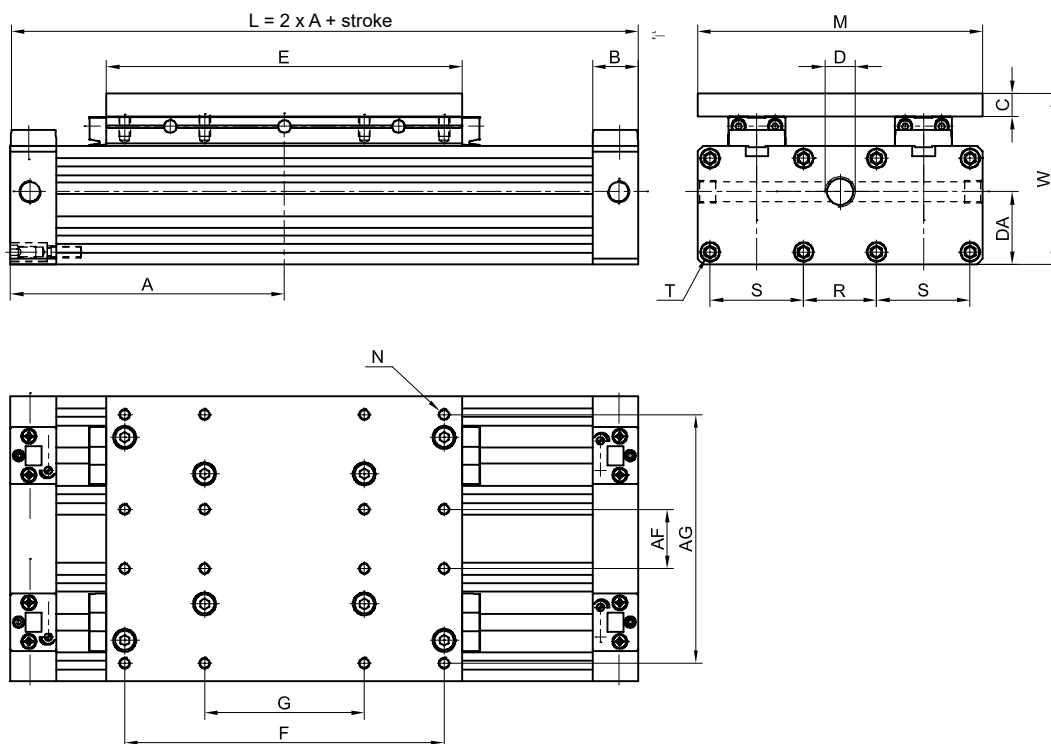

	Ø 25	Ø 32	Ø 40	Ø 50	Ø 63
<b>A</b>	100	120	150	180	215
<b>AF</b>	21	26	35	44	55
<b>AG</b>	79	109	133	164	195
<b>B</b>	20	20	24	24	30
<b>C</b>	8	10	12	15	15
<b>D</b>	G1/4 - 11.7	G1/4 - 11.7	G3/8 - 11.7	G3/8 - 11.7	G1/2 - 13
<b>DA</b>	25.5	40	47	59	71
<b>E</b>	116	156	200	260	313
<b>F</b>	100	140	180	220	280
<b>G</b>	50	70	90	110	140
<b>M</b>	92	125	153	184	218
<b>N</b>	M4	M5	M6	M8	M8
<b>R</b>	17	32	45	43	47
<b>□ S</b>	□ 33 x 33	□ 41 x 41	□ 51 x 51	□ 63 x 63	□ 78 x 78
<b>T</b>	M4 - 9	M5 - 10	M6 - 12	M8 - 12	M8 - 12
<b>W</b>	61	75	91	111	128.5

### ORDER NUMBER CONSTRUCTION

**11 . 520 D . 0100 ZP**

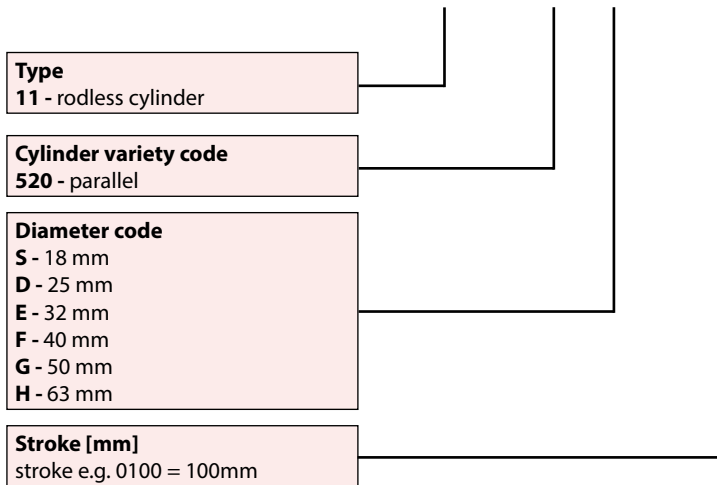

### ORDERING PROCEDURE

The order should include: name, nominal diameter, cylinder stroke, order number and the number of pieces, e.g.:

**Rodless cylinder ZP type parallel Ø25 stroke 100 mm no. 11.520D.0100ZP 1 pc.**

### DESIGN FEATURES

Gripping cylinders have different functions in the drive systems. The most common applications:

- Gripping of parts and objects from the outside
- Gripping parts and objects from the inside
- Clasping larger objects
- Opening and closing

The cylinders can be controlled individually or jointly.

The cylinders are equipped with pneumatic cushioning in the end positions in the ZGS version.

Standard mounting plates adapted to different grippers.

ZGF type - has additional stroke length adjustment for precise regulation in the range of +/- 0.1 mm and stroke length limitation.

### EXMAPLE GRIPPING METHODS

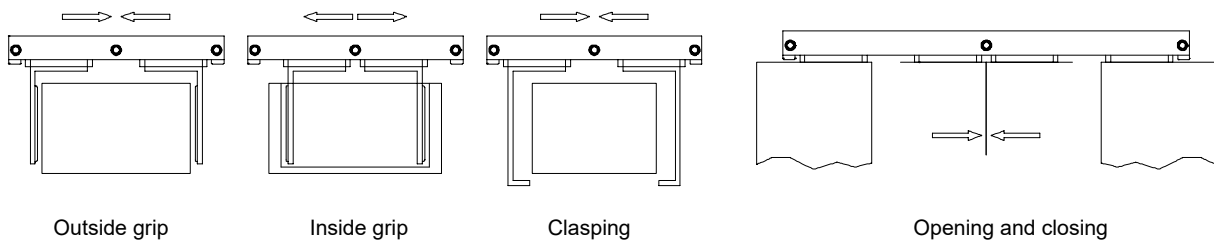

### DIMENSIONS

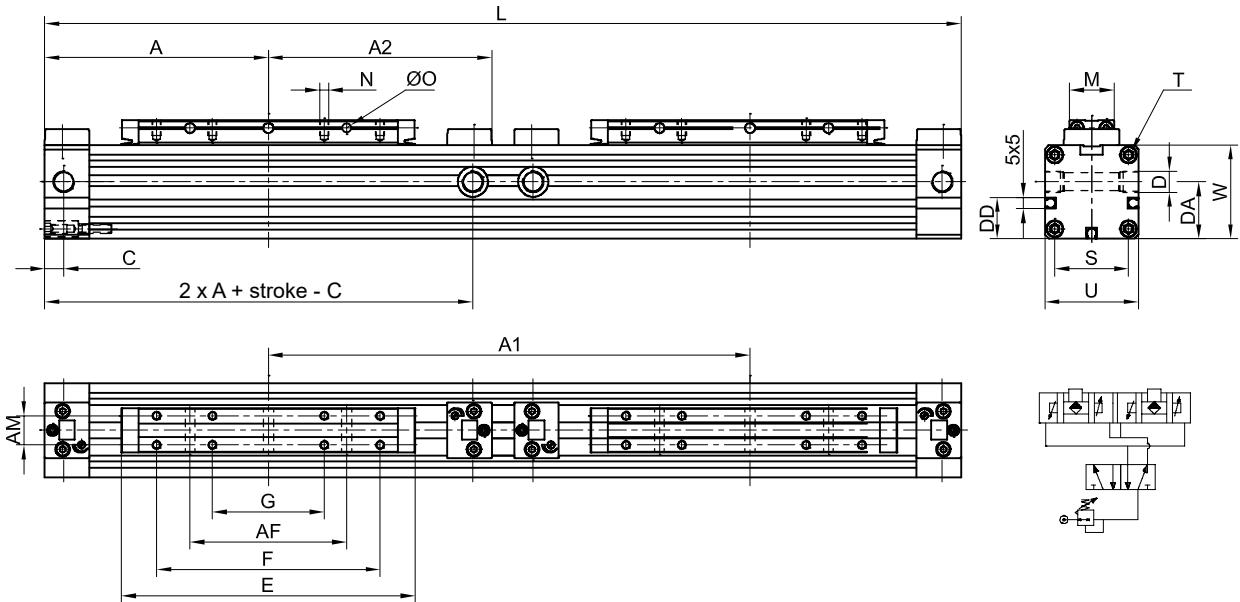

	Ø 18	Ø 25	Ø 32	Ø 40	Ø 50	Ø 63
<b>A</b>	80	100	120	150	180	215
<b>A1min.</b>	160	200	240	300	360	430
<b>A2</b>	A + stroke					
<b>AF</b>	50	70	100	140	180	230
<b>AM</b>	10	13	16	22	29	40
<b>C</b>	6.5	8.5	8.5	13	13	13
<b>D</b>	M7x1 - 6	G1/8 - 7.7	G1/8 - 7.7	G1/4 - 11.7	G1/4 - 7.7	G3/8 - 11.7
<b>DA</b>	17.6	25.5	31.9	37.7	47.6	56
<b>DD</b>	---	18.5	21	29.5	37	44.5
<b>E</b>	103	131	171	220	280	333
<b>F</b>	75	100	140	180	220	280
<b>G</b>	---	50	70	90	110	140
<b>J</b>	3	3.5	4.5	5	6.5	8
<b>L</b>	2 x A + A1					
<b>M</b>	15.5	20	25	33	42	54
<b>N</b>	M3 - 6	M4 - 7	M5 - 9	M6 - 10	M8 - 12.5	M8 - 15
<b>ØO</b>	Ø 3.5	Ø 4.5	Ø 5.5	Ø 7	Ø 7	Ø 9
<b>□S</b>	□ 23.5	□ 33	□ 41	□ 51	□ 63	□ 78
<b>T</b>	M3 - 7	M4 - 9	M5 - 10	M6 - 12	M8 - 12	M8 - 12
<b>□U</b>	□ 30	□ 42	□ 52	□ 63	□ 78	□ 93
<b>W</b>	39	53	65	79	96	113.5

NOTE: Please specify A1 size in your order

### ORDER NUMBER

**Note:** The cylinders are made to order and have individual order numbers

### ORDERING PROCEDURE

In your order, please specify: name, nominal diameter, cylinder stroke, dimension A1 and the number of pieces, e.g.  
**Rodless cylinder ZGS typegripping Ø25 stroke 100 mm, dimension A1 = 400 mm 1 pc.**

# RODLESS CYLINDERS

## ZGK type gripping short version



### DIMENSIONS

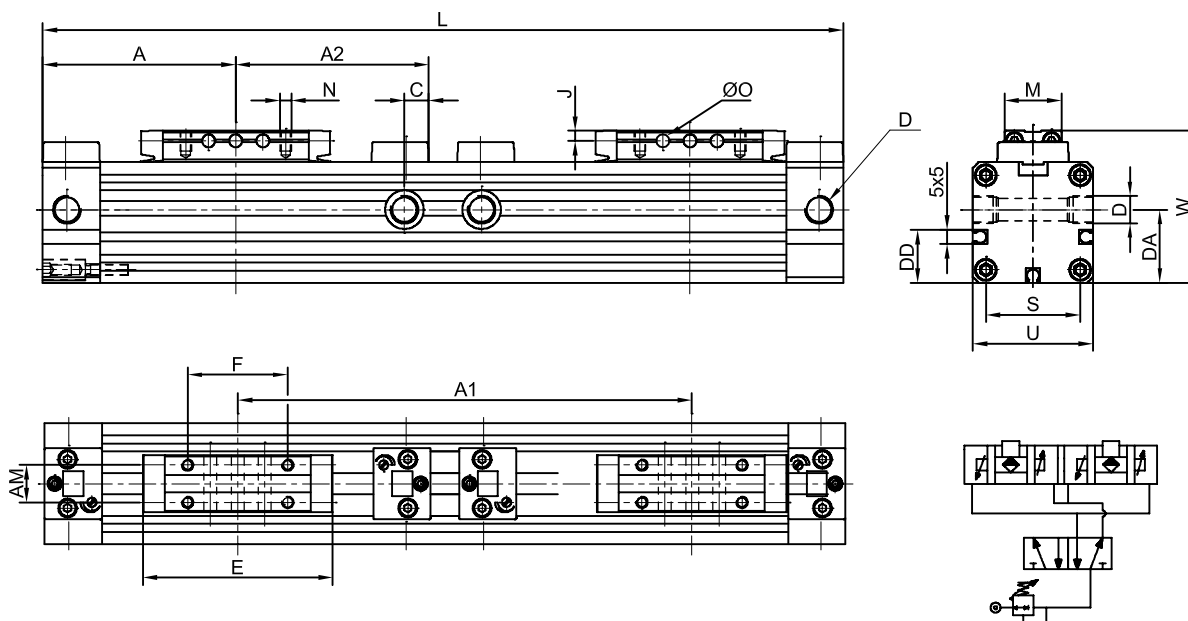

	Ø 18	Ø 25	Ø 32	Ø 40	Ø 50	Ø 63
<b>A</b>	57.5	67.5	77.5	95	105	125
<b>A1min.</b>	115	135	155	190	210	250
<b>A2</b>	A + stroke					
<b>AM</b>	10	13	16	22	29	40
<b>C</b>	6.5	8.5	8.5	13	13	13
<b>D</b>	M7x1 - 6	G1/8 - 7.7	G1/8 - 7.7	G1/4 - 11.7	G1/4 - 7.7	G3/8 - 11.7
<b>DA</b>	17.6	25.5	31.9	37.7	47.6	56
<b>E</b>	58	66	86	110	130	153
<b>F</b>	30	35	55	70	70	100
<b>G</b>	---	50	70	90	110	140
<b>J</b>	3	3.5	4.5	5	6.5	8
<b>L</b>	2 x A + A1					
<b>M</b>	15.5	20	25	33	42	54
<b>N</b>	M3 - 6	M4 - 7	M5 - 9	M6 - 10	M8 - 12.5	M8 - 15
<b>Ø O</b>	Ø 3.5	Ø 4.5	Ø 5.5	Ø 7	Ø 7	Ø 9
<b>□ S</b>	□ 23.5	□ 33	□ 41	□ 51	□ 63	□ 78
<b>T</b>	M3 - 7	M4 - 9	M5 - 10	M6 - 12	M8 - 12	M8 - 12
<b>□ U</b>	□ 30	□ 42	□ 52	□ 63	□ 78	□ 93
<b>W</b>	39	53	65	79	96	113.5

NOTE: Please specify A1 size in your order

### ORDER NUMBER

**Note:** The cylinders are made to order and have individual order numbers

### ORDERING PROCEDURE

In your order, please specify: name, nominal diameter, cylinder stroke, dimension A1 and the number of pieces, e.g.  
**Rodless cylinder type ZGK gripping Ø25 stroke 100 mm, dimension A1 = 400 mm 1 pc.**

### DIMENSIONS

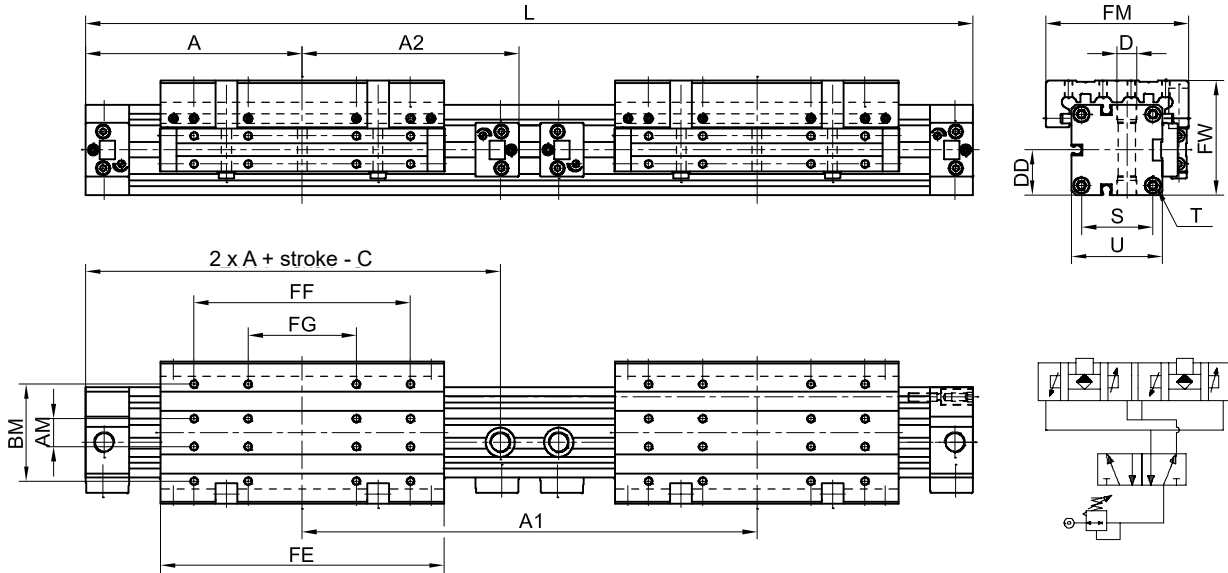

	Ø 18	Ø 25	Ø 32	Ø 40	Ø 50	Ø 63
<b>A</b>	80	100	120	150	180	215
<b>A1min.</b>	160	200	240	300	360	430
<b>A2</b>	A + stroke					
<b>AM</b>	10	13	16	22	29	40
<b>BM</b>	35	45	55	70	85	105
<b>C</b>	6.5	8.5	8.5	13	13	13
<b>D</b>	M7x1 - 6	G1/8 - 7.7	G1/8 - 7.7	G1/4 - 11.7	G1/4 - 7.7	G3/8 - 11.7
<b>DD</b>	15	21	26	31.5	39	46.5
<b>FE</b>	103	131	171	220	280	333
<b>FF</b>	75	100	140	180	220	280
<b>FG</b>	---	50	70	90	110	140
<b>FM</b>	50	66	80	97	116	136
<b>FR</b>	23.2	31.5	39	48.5	60.5	74
<b>FW</b>	39	53	65	79	96	113.5
<b>L</b>	2 x A + A1					
<b>N</b>	M4 - 7.5	M4 - 7	M5 - 9	M6 - 10	M8 - 12.5	M8 - 15
<b>Ø O</b>	Ø 3.5	Ø 4.5	Ø 5.5	Ø 7	Ø 7	Ø 9
<b>□ S</b>	□ 23.5	□ 33	□ 41	□ 51	□ 63	□ 78
<b>T</b>	M3 - 7	M4 - 9	M5 - 10	M6 - 12	M8 - 12	M8 - 12
<b>□ U</b>	□ 30	□ 42	□ 52	□ 63	□ 78	□ 93

NOTE: Please specify A1 size in your order

### ORDER NUMBER

**Note:** The cylinders are made to order and have individual order numbers

### ORDERING PROCEDURE

In your order, please specify: name, nominal diameter, cylinder stroke, dimension A1 and the number of pieces, e.g.  
**Rodless cylinder type ZGF gripping Ø25 stroke 100 mm, dimension A1 = 400 mm 1 pc.**

# RODLESS CYLINDERS

ZGS3 type gripping with 3 supply ports



## DIMENSIONS

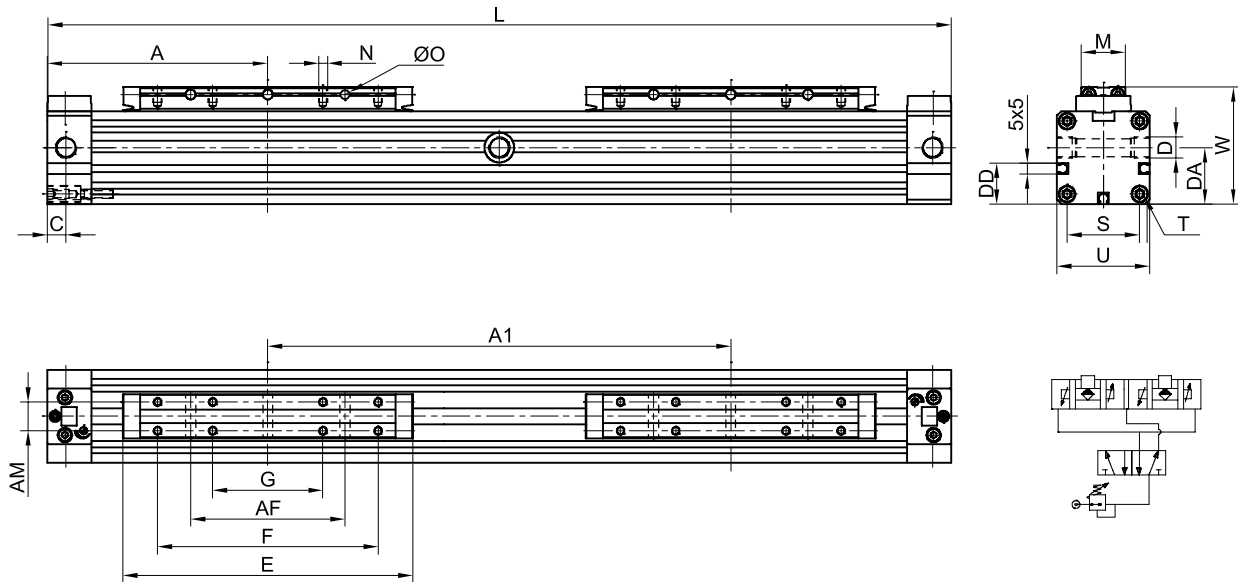

	Ø 18	Ø 25	Ø 32	Ø 40	Ø 50	Ø 63
<b>A</b>	80	100	120	150	180	215
<b>A1min.</b>	160	200	240	300	360	430
<b>AF</b>	50	70	100	140	180	230
<b>AM</b>	10	13	16	22	29	40
<b>C</b>	6.5	8.5	8.5	13	13	13
<b>D</b>	M7x1 - 6	G1/8 - 7.7	G1/8 - 7.7	G1/4 - 11.7	G1/4 - 7.7	G3/8 - 11.7
<b>DA</b>	17.6	25.5	31.9	37.7	47.6	56
<b>E</b>	103	131	171	220	280	333
<b>F</b>	75	100	140	180	220	280
<b>G</b>	---	50	70	90	110	140
<b>J</b>	3	3.5	4.5	5	6.5	8
<b>L</b>	$2 \times A + A1$					
<b>M</b>	15.5	20	25	33	42	54
<b>N</b>	M3 - 6	M4 - 7	M5 - 9	M6 - 10	M8 - 12.5	M8 - 15
<b>Ø O</b>	Ø 3.5	Ø 4.5	Ø 5.5	Ø 7	Ø 7	Ø 9
<b>□ S</b>	□ 23.5	□ 33	□ 41	□ 51	□ 63	□ 78
<b>T</b>	M3 - 7	M4 - 9	M5 - 10	M6 - 12	M8 - 12	M8 - 12
<b>□ U</b>	□ 30	□ 42	□ 52	□ 63	□ 78	□ 93
<b>W</b>	39	53	65	79	96	113.5

NOTE: Please specify A1 size in your order

## ORDER NUMBER

**Note:** The cylinders are made to order and have individual order numbers

## ORDERING PROCEDURE

In your order, please specify: name, nominal diameter, cylinder stroke, dimension A1 and the number of pieces, e.g.  
**Rodless cylinder ZGS3 type gripping Ø25 stroke 100 mm, dimension A1 = 400 mm 1 pc.**

### DIMENSIONS

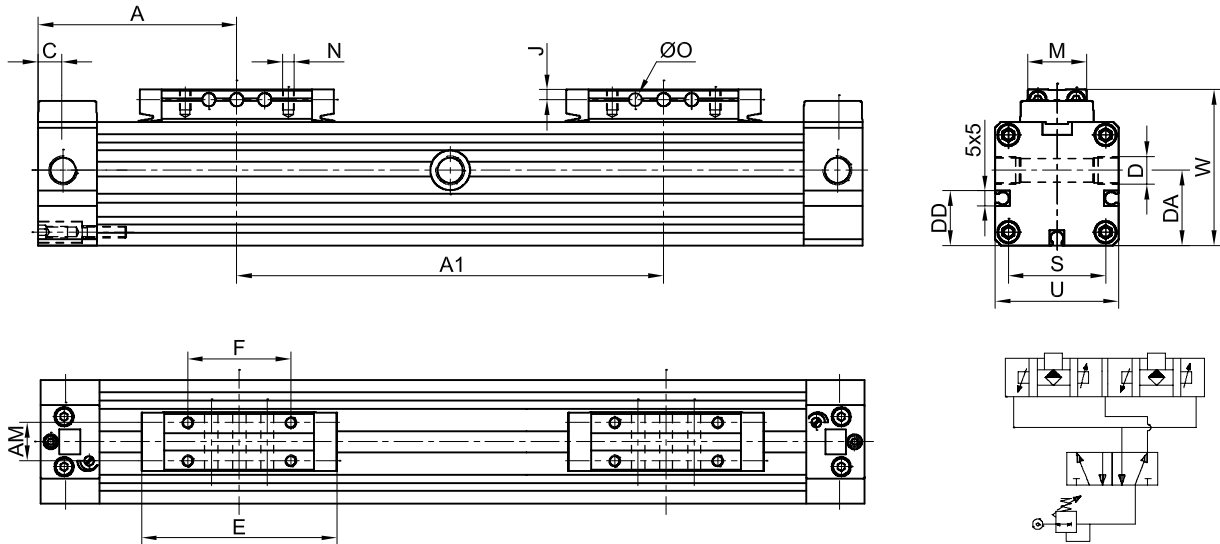

	Ø 18	Ø 25	Ø 32	Ø 40	Ø 50	Ø 63
<b>A</b>	57.5	67.5	77.5	95	105	125
<b>A1min.</b>	115	135	155	190	210	250
<b>AM</b>	10	13	16	22	29	40
<b>C</b>	6.5	8.5	8.5	13	13	13
<b>D</b>	M7x1 - 6	G1/8 - 8	G1/8 - 8	G1/4 - 11.7	G1/4 - 7.7	G3/8 - 11.7
<b>DA</b>	17.6	25.5	31.9	37.7	47.6	56
<b>E</b>	58	66	86	110	130	153
<b>F</b>	30	35	55	70	70	100
<b>G</b>	---	50	70	90	110	140
<b>J</b>	3	3.5	4.5	5	6.5	8
<b>L</b>	2 x A + A1					
<b>M</b>	15.5	20	25	33	42	54
<b>N</b>	M3 - 6	M4 - 7	M5 - 9	M6 - 10	M8 - 12.5	M8 - 15
<b>Ø O</b>	Ø 3.5	Ø 4.5	Ø 5.5	Ø 7	Ø 7	Ø 9
<b>□ S</b>	□ 23.5	□ 33	□ 41	□ 51	□ 63	□ 78
<b>T</b>	M3 - 7	M4 - 9	M5 - 10	M6 - 12	M8 - 12	M8 - 12
<b>□ U</b>	□ 30	□ 42	□ 52	□ 63	□ 78	□ 93
<b>W</b>	39	53	65	79	96	113.5

NOTE: Please specify A1 size in your order

### ORDER NUMBER

**Note:** The cylinders are made to order and have individual order numbers

### ORDERING PROCEDURE

In your order, please specify: name, nominal diameter, cylinder stroke, dimension A1 and the number of pieces, e.g.  
**Rodless cylinder type ZGK3 gripping Ø25 stroke 100 mm, dimension A1 = 400 mm 1 pc.**



# RODLESS CYLINDERS

## ZGF3 type gripping with 3 supply ports



### DIMENSIONS

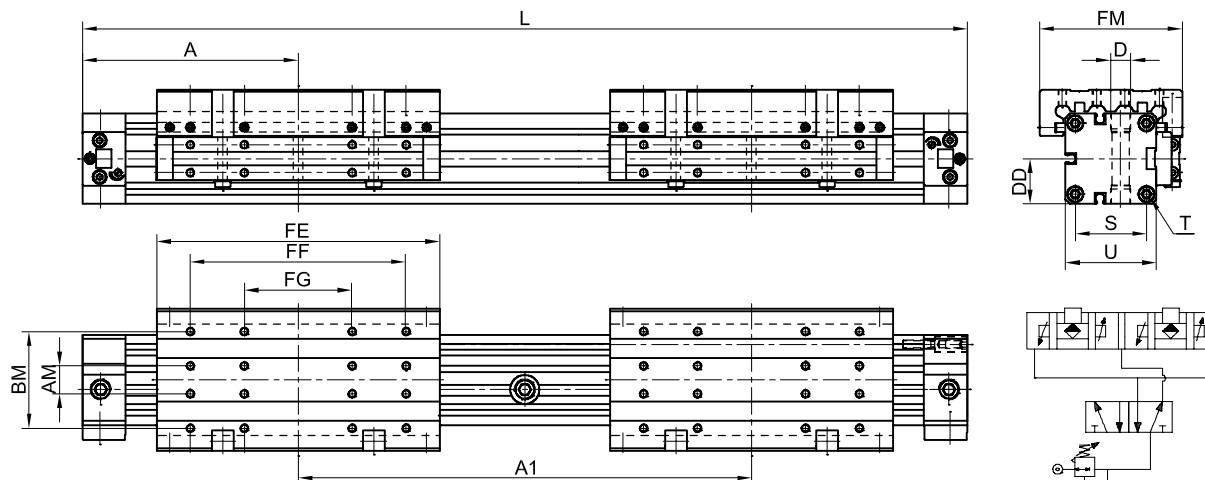

	Ø 18	Ø 25	Ø 32	Ø 40	Ø 50	Ø 63
<b>A</b>	80	100	120	150	180	215
<b>A1min.</b>	160	200	240	300	360	430
<b>AM</b>	10	13	16	22	29	40
<b>BM</b>	35	45	55	70	85	105
<b>C</b>	6.5	8.5	8.5	13	13	13
<b>D</b>	M7x1 - 6	G1/8 - 7.7	G1/8 - 7.7	G1/4 - 11.7	G1/4 - 7.7	G3/8 - 11.7
<b>DD</b>	15	21	26	31.5	39	46.5
<b>FE</b>	103	131	171	220	280	333
<b>FF</b>	75	100	140	180	220	280
<b>FG</b>	---	50	70	90	110	140
<b>FM</b>	50	66	80	97	116	136
<b>FR</b>	23.2	31.5	39	48.5	60.5	74
<b>FW</b>	39	53	65	79	96	113.5
<b>L</b>	$2 \times A + A1$					
<b>N</b>	M4 - 7.5	M4 - 7	M5 - 9	M6 - 10	M8 - 12.5	M8 - 15
<b>Ø O</b>	Ø 3.5	Ø 4.5	Ø 5.5	Ø 7	Ø 7	Ø 9
<b>□ S</b>	□ 23.5	□ 33	□ 41	□ 51	□ 63	□ 78
<b>T</b>	M3 - 7.5	M4 - 10	M5 - 12	M6 - 15	M8 - 20	M8 - 20
<b>□ U</b>	□ 30	□ 42	□ 52	□ 63	□ 78	□ 93

NOTE: Please specify A1 size in your order

### ORDER NUMBER

**Note:** The cylinders are made to order and have individual order numbers

### ORDERING PROCEDURE

In your order, please specify: name, nominal diameter, cylinder stroke, dimension A1 and the number of pieces, e.g.  
**Rodless cylinder ZGF3 type gripping Ø25 stroke 100 mm, dimension A1 = 400 mm 1 pc.**

### DESIGN FEATURES

- The cylinders designed for higher operating torques over large lengths
  - By mounting double piston rods and double guides, larger torques can be transmitted
  - Tandem type cylinders are used where higher weights are to be lifted
- Application examples:
- lifting gear booms
  - lifting gear
  - movement of paint spray guns or lances
- The cylinders can be manufactured with any working stroke
  - The cylinders are equipped with pneumatic cushioning in end positions

Diameter D of the cylinder	Force / 6 bar	Pneumatic cushioning	Weight of cylinder in relation to stroke 0 mm	Weight increase / stroke
18	140 N	15 mm	0.6 kg	1.5 kg / 1000 mm
25	270 N	18 mm	1.3 kg	2.6 kg / 1000 mm
32	440 N	24 mm	3.6 kg	3.6 kg / 1000 mm
40	680 N	34 mm	6.2 kg	4.9 kg / 1000 mm
50	1060 N	40 mm	11.1 kg	7.5 kg / 1000 mm
63	1680 N	49 mm	18.6 kg	10 kg / 1000 mm

# RODLESS CYLINDERS

## ZTS Tandem type



### DIMENSIONS

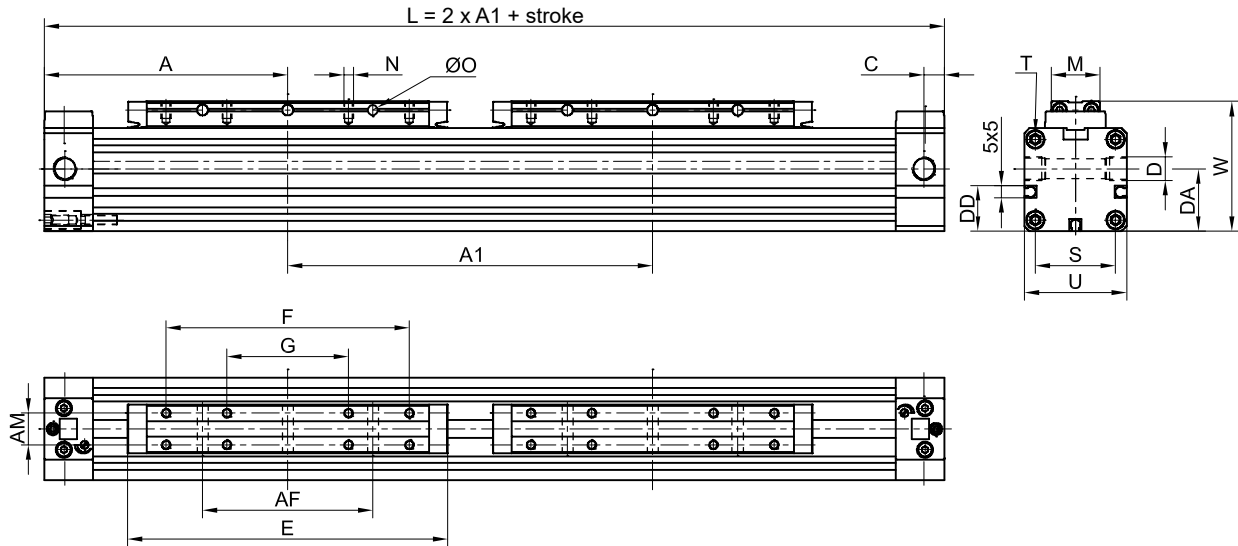

	Ø 18	Ø 25	Ø 32	Ø 40	Ø 50	Ø 63
<b>A</b>	80	100	120	150	180	215
<b>A1min.</b>	127	160	200	252	312	370
<b>AF</b>	50	70	100	140	180	230
<b>AM</b>	10	13	16	22	29	40
<b>C</b>	6.5	8.5	8.5	13	13	13
<b>D</b>	M7x1 - 6	G1/8 - 7.7	G1/8 - 7.7	G1/4 - 11.7	G1/4 - 11.7	G3/8 - 11.7
<b>DA</b>	17.6	25.5	31.9	37.7	47.6	56
<b>E</b>	103	131	171	220	280	333
<b>F</b>	75	100	140	180	220	280
<b>G</b>	---	50	70	90	110	140
<b>J</b>	3	3.5	4.5	5	6.5	8
<b>M</b>	15.5	20	25	33	42	54
<b>N</b>	M3 - 6	M4 - 7	M5 - 9	M6 - 10	M8 - 12.5	M8 - 15
<b>Ø O</b>	Ø 3.5	Ø 4.5	Ø 5.5	Ø 7	Ø 7	Ø 9
<b>□ S</b>	□ 23.5	□ 33	□ 41	□ 51	□ 63	□ 78
<b>T</b>	M3 - 7	M4 - 9	M5 - 10	M6 - 12	M8 - 12	M8 - 12
<b>□ U</b>	□ 30	□ 42	□ 52	□ 63	□ 78	□ 93
<b>W</b>	39	53	65	79	96	113.5

NOTE: Please specify A1 size in your order

### ORDER NUMBER

**Note:** The cylinders are made to order and have individual order numbers

### ORDERING PROCEDURE

In your order, please specify: name, nominal diameter, cylinder stroke, dimension A1 and the number of pieces, e.g.  
**ZTS Tandem type rodless cylinder Ø25 stroke 100 mm, dimension A1 = 400 mm 1 pc.**

### DIMENSIONS

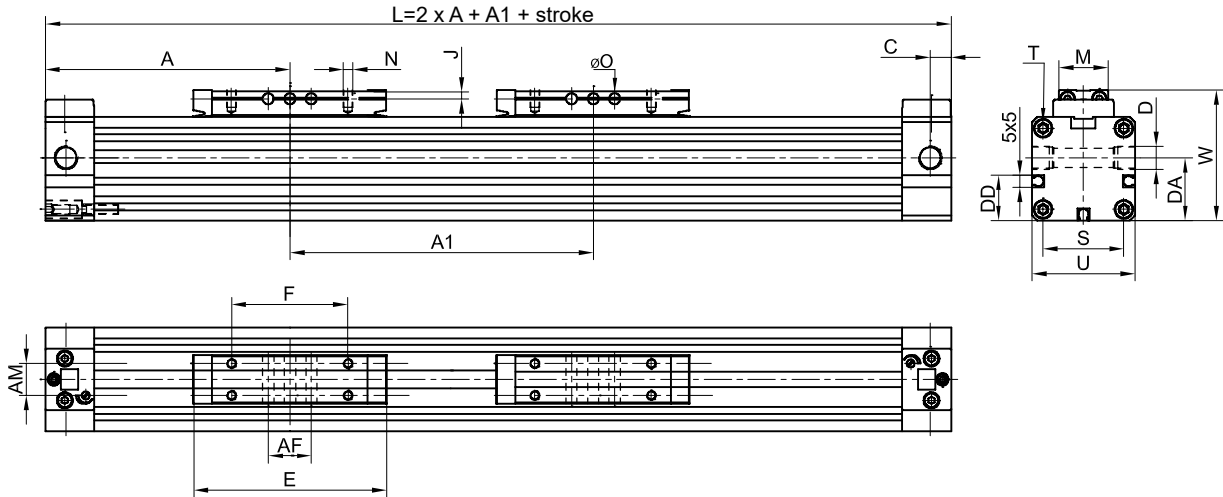

	Ø 18	Ø 25	Ø 32	Ø 40	Ø 50	Ø 63
<b>A</b>	57.5	67.5	77.5	95	105	125
<b>A1min.</b>	82	95	115	142	162	190
<b>AM</b>	10	13	16	22	29	40
<b>C</b>	6.5	8.5	8.5	13	13	13
<b>D</b>	M7x1 - 6	G1/8 - 7.7	G1/8 - 7.7	G1/4 - 11.7	G1/4 - 11.7	G3/8 - 11.7
<b>DA</b>	17.6	25.5	31.9	37.7	47.6	56
<b>E</b>	58	66	86	110	130	153
<b>F</b>	30	35	55	70	70	100
<b>J</b>	3	3.5	4.5	5	6.5	8
<b>M</b>	15.5	20	25	33	42	54
<b>N</b>	M3 - 6	M4 - 7	M5 - 9	M6 - 10	M8 - 12.5	M8 - 15
<b>Ø O</b>	Ø 3.5	Ø 4.5	Ø 5.5	Ø 7	Ø 7	Ø 9
<b>□ S</b>	□ 23.5	□ 33	□ 41	□ 51	□ 63	□ 78
<b>T</b>	M3 - 7	M4 - 9	M5 - 10	M6 - 12	M8 - 12	M8 - 12
<b>□ U</b>	□ 30	□ 42	□ 52	□ 63	□ 78	□ 93
<b>W</b>	39	53	65	79	96	113.5

NOTE: Please specify A1 size in your order

### ORDER NUMBER

**Note:** The cylinders are made to order and have individual order numbers

### ORDERING PROCEDURE

In your order, please specify: name, nominal diameter, cylinder stroke, dimension A1 and the number of pieces, e.g.  
**ZTK Tandem type rodless cylinder Ø25 stroke 100 mm, dimension A1 = 400 mm 1 pc.**

# RODLESS CYLINDERS

ZTF Tandem type with guide



## DIMENSIONS

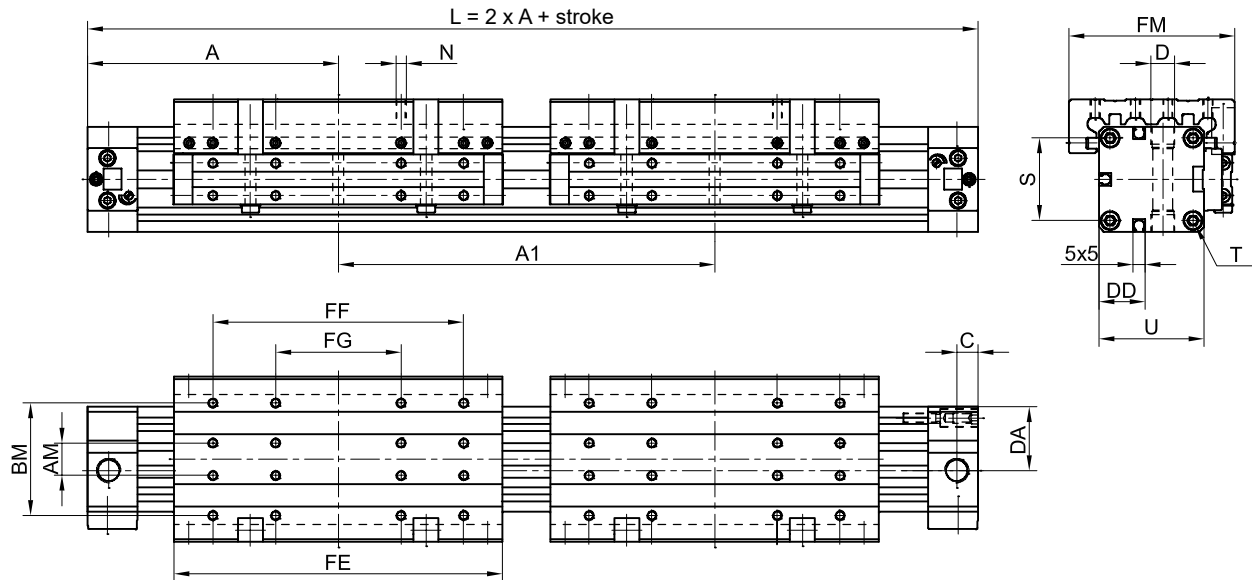

	Ø 18	Ø 25	Ø 32	Ø 40	Ø 50	Ø 63
<b>A</b>	80	100	120	150	180	215
<b>A1min.</b>	127	160	200	252	312	370
<b>AM</b>	10	13	16	22	29	40
<b>BM</b>	35	45	55	70	85	105
<b>C</b>	6.5	8.5	8.5	13	13	13
<b>D</b>	M7x1 - 6	G1/8 - 7.7	G1/8 - 7.7	G1/4 - 11.7	G1/4 - 11.7	G3/8 - 11.7
<b>FE</b>	103	131	171	220	280	333
<b>FF</b>	75	100	140	180	220	280
<b>FG</b>	---	50	70	90	110	140
<b>FM</b>	50	66	80	97	116	136
<b>FW</b>	39	53	65	79	96	113.5
<b>N</b>	M4 - 7	M4 - 9	M5 - 10	M6 - 15	M8 - 12	M8 - 12
<b>Ø O</b>	Ø 3.5	Ø 4.5	Ø 5.5	Ø 7	Ø 7	Ø 9
<b>□ S</b>	□ 23.5	□ 33	□ 41	□ 51	□ 63	□ 78
<b>T</b>	M3 - 8	M4 - 10	M5 - 12	M6 - 15	M8 - 20	M8 - 20
<b>□ U</b>	□ 30	□ 42	□ 52	□ 63	□ 78	□ 93

NOTE: Please specify A1 size in your order

## ORDER NUMBER

**Note:** The cylinders are made to order and have individual order numbers

## ORDERING PROCEDURE

In your order, please specify: name, nominal diameter, cylinder stroke, dimension A1 and the number of pieces, e.g.  
ZTF Tandem type **rodless cylinder Ø25 stroke 100 mm, dimension A1 = 200 mm 1 pc.**

### DESIGN FEATURES

- Rodless cylinder consisting of two independent pneumatic cylinders with independent supply ports.
- Both piston assemblies are mechanically joined.
- In this case, the acting force of the pneumatic cylinders is increased and the ability to carry higher loads is increased.
- The cylinders are fitted with pneumatic cushioning in the end positions of the slide valve.

Diameter D of the cylinder	Force / 6 bar	Pneumatic cushioning	Weight of cylinder in relation to stroke 0 mm	Weight increase / stroke
18	280 N	15 mm	1.2 kg	3 kg / 1000 mm
25	540 N	18 mm	2.6 kg	5.2 kg / 1000 mm
32	880 N	24 mm	7.2 kg	7.2 kg / 1000 mm
40	1360 N	34 mm	12.4 kg	9.8 kg / 1000 mm
50	2120 N	40 mm	22.2 kg	15 kg / 1000 mm
63	3360 N	49 mm	37.2 kg	20.4 kg / 1000 mm

# RODLESS CYLINDERS

## ZDS type double-acting with block



### DIMENSIONS

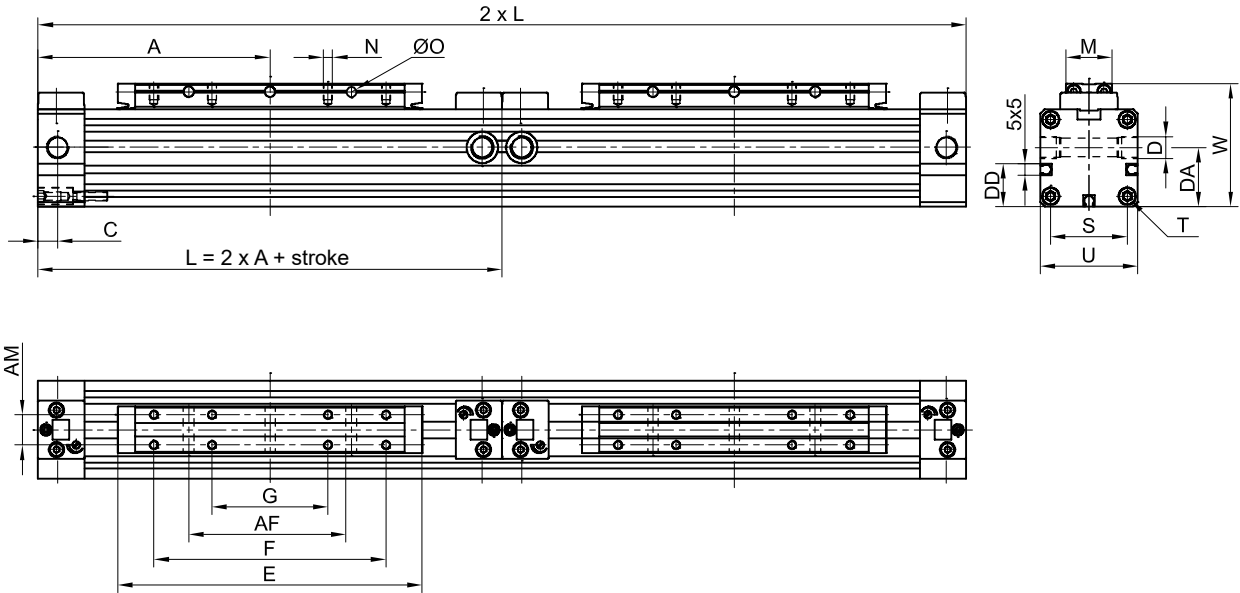

	Ø 18	Ø 25	Ø 32	Ø 40	Ø 50	Ø 63
<b>A</b>	80	100	120	150	180	215
<b>AF</b>	50	70	100	140	180	230
<b>AG</b>	---	35	50	70	90	115
<b>AM</b>	10	13	16	22	29	40
<b>C</b>	6.5	8.5	8.5	13	13	13
<b>D</b>	M7x1 - 6	G1/8 - 7.7	G1/8 - 7.7	G1/4 - 11.7	G1/4 - 11.7	G3/8 - 11.7
<b>DA</b>	17.6	25.5	31.9	37.7	47.6	56
<b>E</b>	103	131	171	220	280	333
<b>F</b>	75	100	140	180	220	280
<b>G</b>	---	50	70	90	110	140
<b>J</b>	3	3.5	4.5	5	6.5	8
<b>M</b>	15.5	20	25	33	42	54
<b>N</b>	M3 - 6	M4 - 7	M5 - 9	M6 - 10	M8 - 12.5	M8 - 15
<b>Ø O</b>	Ø 3.5	Ø 4.5	Ø 5.5	Ø 7	Ø 7	Ø 9
<b>□ S</b>	□ 23.5	□ 33	□ 41	□ 51	□ 63	□ 78
<b>T</b>	M3 - 7	M4 - 9	M5 - 10	M6 - 12	M8 - 12	M8 - 12
<b>□ U</b>	□ 30	□ 42	□ 52	□ 63	□ 78	□ 93
<b>W</b>	39	53	65	79	96	113.5

### ORDER NUMBER CONSTRUCTION

**11 . 540 D . 0100 ZDS**

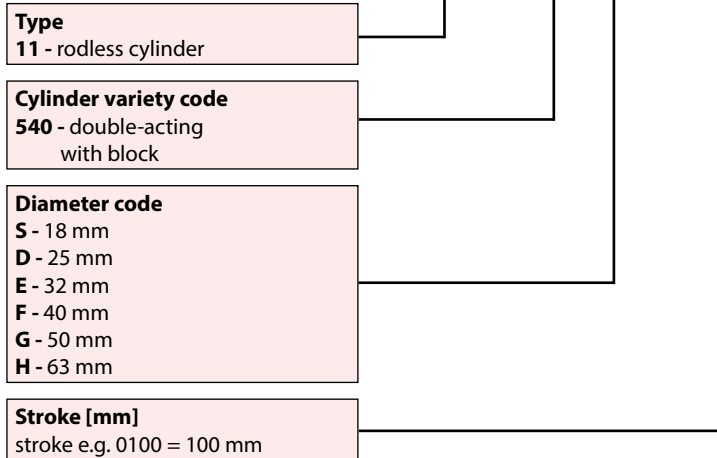

### ORDERING PROCEDURE

The order should include: name, nominal diameter, cylinder stroke, order number and the number of pieces, e.g.:

**Rodless cylinder ZDS type double-acting with block Ø25 stroke 100 mm no. 11.540D.0100ZDS 1 pc.**



# RODLESS CYLINDERS

ZDK type double-acting with block,  
short version



## DIMENSIONS

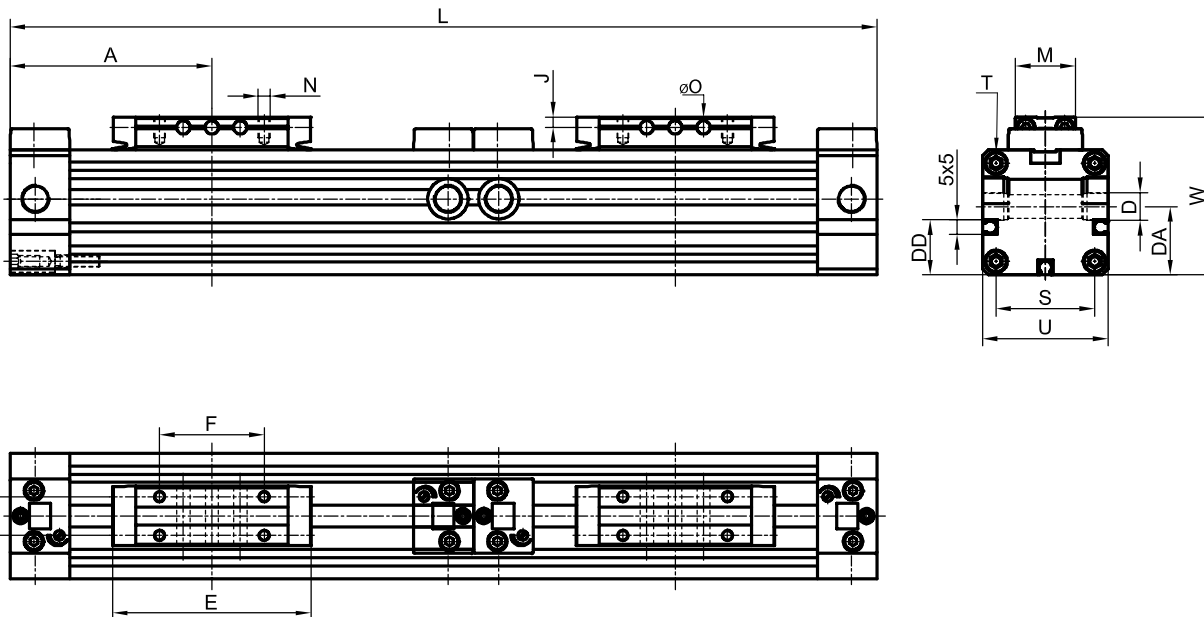

	Ø 18	Ø 25	Ø 32	Ø 40	Ø 50	Ø 63
<b>A</b>	57.5	67.5	77.5	95	105	125
<b>AM</b>	10	13	16	22	29	40
<b>C</b>	6.5	8.5	8.5	13	13	13
<b>D</b>	M7x1 - 6	G1/8 - 7.7	G1/8 - 7.7	G1/4 - 11.7	G1/4 - 11.7	G3/8 - 11.7
<b>DA</b>	17.6	25.5	31.9	37.7	47.6	56
<b>E</b>	58	66	86	110	130	153
<b>F</b>	30	35	55	70	70	100
<b>J</b>	3	3.5	4.5	5	6.5	8
<b>M</b>	15.5	20	25	33	42	54
<b>N</b>	M3 - 6	M4 - 7	M5 - 9	M6 - 10	M8 - 12.5	M8 - 15
<b>Ø O</b>	Ø 3.5	Ø 4.5	Ø 5.5	Ø 7	Ø 7	Ø 9
<b>□ S</b>	□ 23.5	□ 33	□ 41	□ 51	□ 63	□ 78
<b>T</b>	M3 - 7.5	M4 - 10	M5 - 12	M6 - 15	M8 - 20	M8 - 20
<b>□ U</b>	□ 30	□ 42	□ 52	□ 63	□ 78	□ 93
<b>W</b>	39	53	65	79	96	113.5

## ORDER NUMBER CONSTRUCTION

**11 . 540 D . 0100 ZDK**

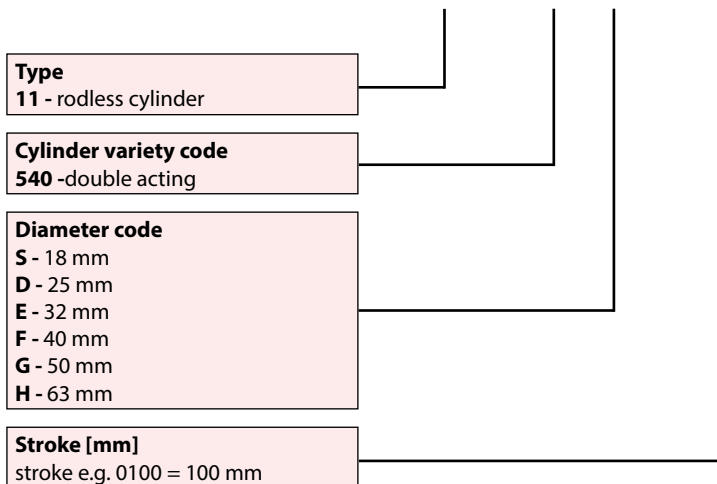

## ORDERING PROCEDURE

The order should include: name, nominal diameter, cylinder stroke, order number and the number of pieces, e.g.:

**Rodless cylinder ZDK type double-acting with block Ø25 stroke 100 mm no. 11.540D.0100ZDK 1 pc.**

# RODLESS CYLINDERS

ZDF type double-acting with block,  
short version



## DIMENSIONS

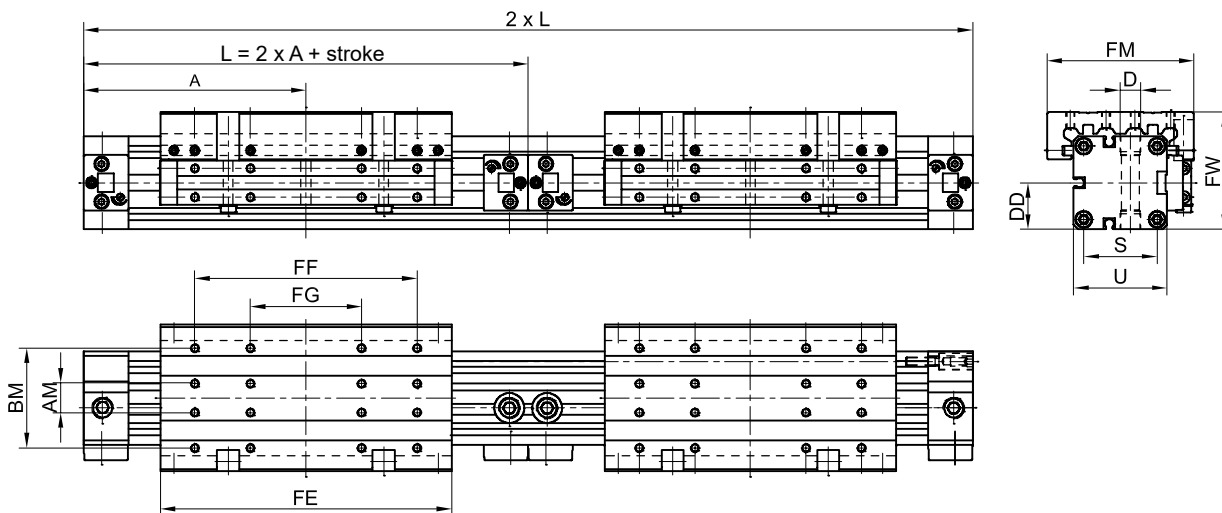

	Ø 18	Ø 25	Ø 32	Ø 40	Ø 50	Ø 63
<b>A</b>	80	100	120	150	180	215
<b>AM</b>	10	13	16	22	29	40
<b>BM</b>	35	45	55	70	85	105
<b>C</b>	6.5	8.5	8.5	13	13	13
<b>D</b>	M7x1 - 6	G1/8 - 7.7	G1/8 - 7.7	G1/4 - 11.7	G1/4 - 11.7	G3/8 - 11.7
<b>FE</b>	103	131	171	220	280	333
<b>FF</b>	75	100	140	180	220	280
<b>FG</b>	---	50	70	90	110	140
<b>FM</b>	50	66	80	97	116	136
<b>FW</b>	39	53	65	79	96	113.5
<b>N</b>	M4 - 7.5	M4 - 10	M5 - 12	M6 - 15	M8 - 20	M8 - 20
□ <b>S</b>	□ 23.5	□ 33	□ 41	□ 51	□ 63	□ 78
<b>T</b>	M3 - 8	M4 - 10	M5 - 12	M6 - 15	M8 - 20	M8 - 20
□ <b>U</b>	□ 30	□ 42	□ 52	□ 63	□ 78	□ 93

## ORDER NUMBER CONSTRUCTION

**11 . 540 D . 0100 ZDF**

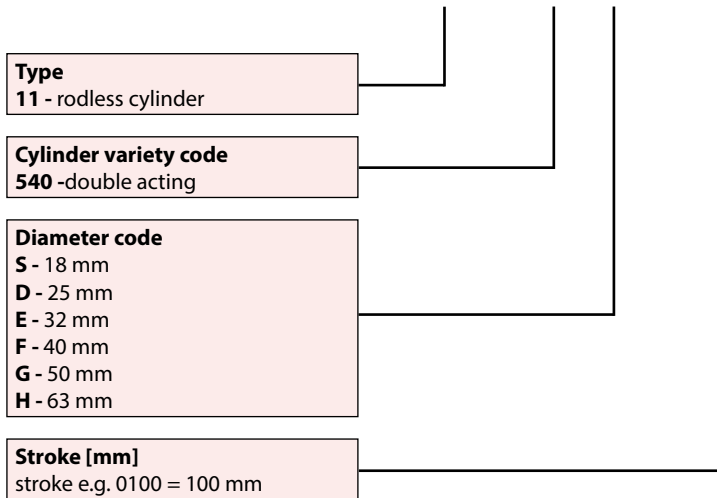

## ORDERING PROCEDURE

The order should include: name, nominal diameter, cylinder stroke, order number and the number of pieces, e.g.:

**Rodless cylinder ZDF type double acting with block and guides Ø25 stroke 100 mm  
no. 11.540D.0100ZDF 1 pc.**



## MOUNTING BRACKET FB TYPE

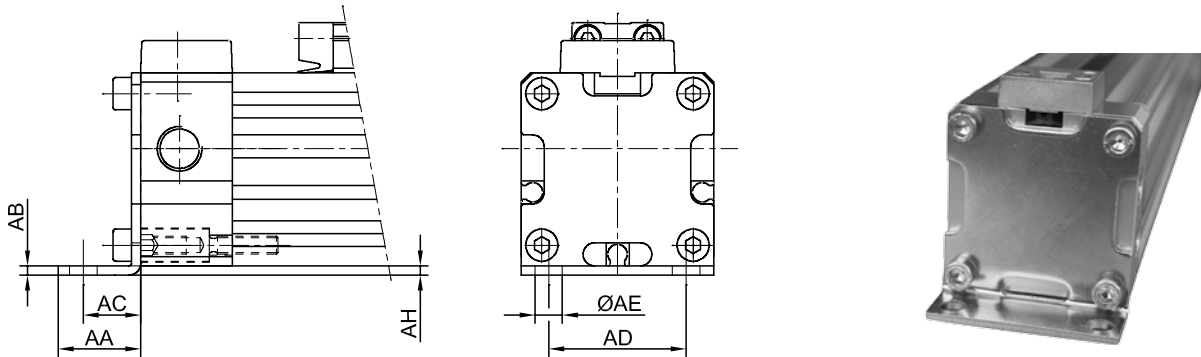

	Ø 18	Ø 25	Ø 32	Ø 40	Ø 50	Ø 63
AA	15	18	20	30	28	30
AB	2	2	2.5	3	3	3
AC	10	12.5	13.5	17.5	20	21
AD	20	30	40	50	60	75
AE	Ø6	Ø6	Ø7	Ø9	Ø9	Ø11
AH	2	2	3	3.5	3	4.5
Order number	10.594S.01	10.594D.01	10.594E.01	10.594F.01	10.594G.01	10.594H.01

The set includes 2 pcs. of the bracket and 8 pcs. of mounting bolts

## INTERMEDIATE MOUNTING ELEMENT MB TYPE

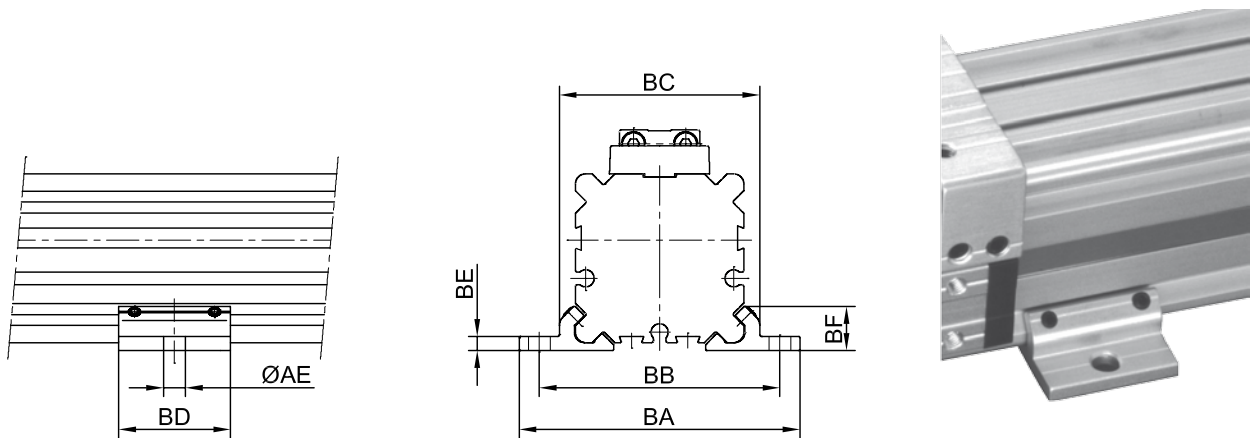

	Ø 18	Ø 25	Ø 32	Ø 40	Ø 50	Ø 63
AE	Ø6	Ø6	Ø7	Ø9	Ø9	Ø11
AH	2	2	3	3	3	4.5
BA	56	70	85	105	122	144
BB	46	60	73	90	106	125
BC	36.5	50	61.5	75	91	107
BD	23	28	33	38	43	48
BE	2.5	3.5	4	4.5	5	6
BF	8.25	11	13.8	16	19	22
Order number	10.594S.02	10.594D.02	10.594E.02	10.594F.02	10.594G.02	10.594H.02

The set includes 2 pcs. of mounting elements

# MOUNTING ELEMENTS

for rodless cylinders



## MOUNTING BLOCK FB TYPE

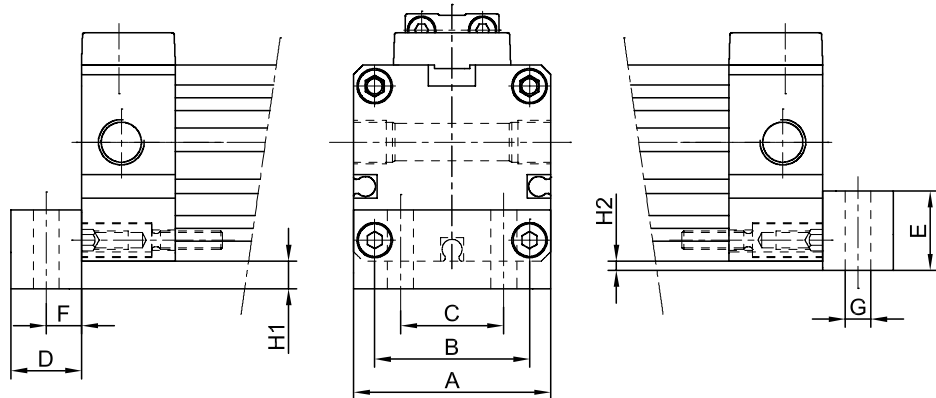
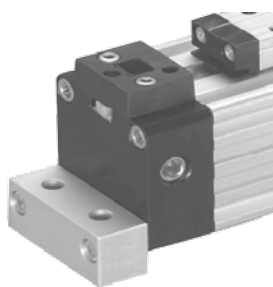

	Ø 18	Ø 25	Ø 32	Ø 40	Ø 50	Ø 63
<b>A</b>	30	42	52	63	78	93
<b>B</b>	23.5	33	41	51	63	73
<b>C</b>	14	22	23.5	30	39	52
<b>D</b>	10	15	15	15	16	20
<b>E</b>	14.5	17	20	23	26	27.5
<b>F</b>	5	7.5	7.5	7.5	8	10
<b>G</b>	Ø4.5	Ø5.5	Ø7	Ø9	Ø9	Ø11
<b>H1</b>	6	6	6	8	8	8
<b>H2</b>	2	2	3	3	3	4.5
	M5 x 14	M4 x 20	M5 x 20	M6 x 20	M8 x 20	M8 x 20
<b>Order number</b>	<b>10.594S.03</b>	<b>10.594D.03</b>	<b>10.594E.03</b>	<b>10.594F.03</b>	<b>10.594G.03</b>	<b>10.594H.03</b>

The set includes 2 pieces of mounting blocks and 4 pieces of mounting bolts

## INTERMEDIATE MOUNTING BRACKET MB TYPE

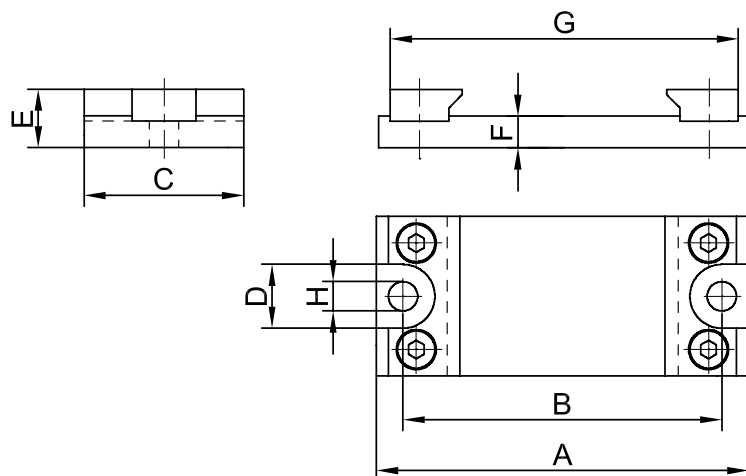

	Ø 18	Ø 25	Ø 32	Ø 40	Ø 50	Ø 63
<b>A</b>	56	70	85	105	122	144
<b>B</b>	45	60	73	90.5	105	125
<b>C</b>	30	30	40	40	40	50
<b>D</b>	12	12	12.5	16	16	19
<b>E</b>	11	13	15	18	20.5	21.5
<b>F</b>	6	6	6	8	8	8
<b>G</b>	50.6	65.5	77.5	90.5	107.5	122.5
<b>H</b>	Ø5.5	Ø5.5	Ø6.6	Ø9	Ø9	Ø11
<b>Order number</b>	<b>10.594S.04</b>	<b>10.594D.04</b>	<b>10.594E.04</b>	<b>10.594F.04</b>	<b>10.594G.04</b>	<b>10.594H.04</b>

## DEFLECTION DIAGRAM FOR SUPPORT MB TYPE

If very long cylinders are used or heavy loads are applied, the tube may become deformed. The use of intermediate supports eliminates this effect.

### With a deflection of 0.5 mm

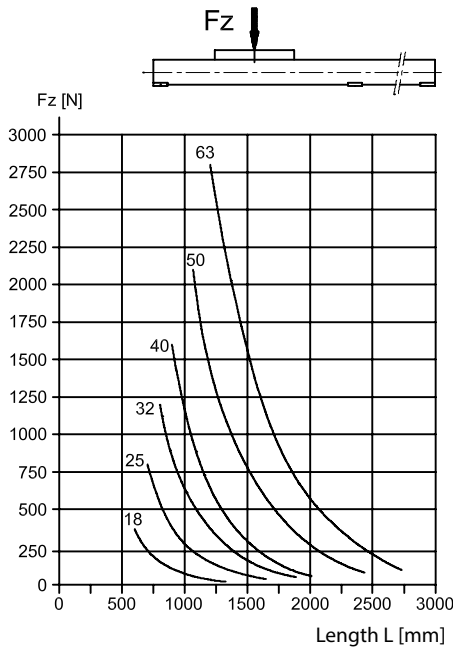

### With a deflection of 1 mm

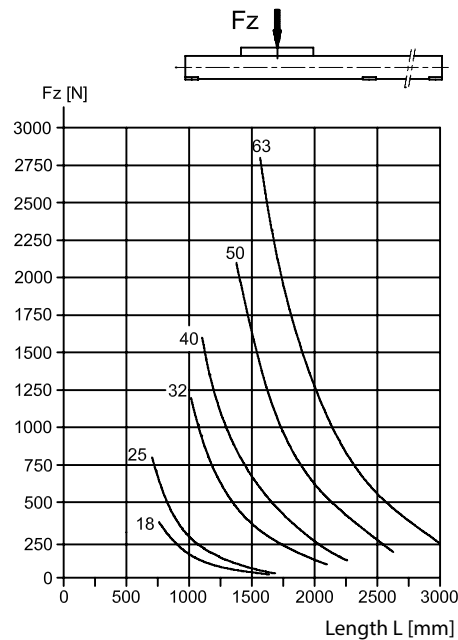

### EXAMPLE:

A cylinder with a diameter of  $\varnothing 25$  should deform by a maximum of 0.5 mm at a load of 500N. According to the drawing, the cylinder should be 750 mm long. A longer cylinder should be additionally supported.

### OTHER CASES:

In the case of very long cylinders installed without additional support, they must be mounted in additional profiles as shown in the figure below.

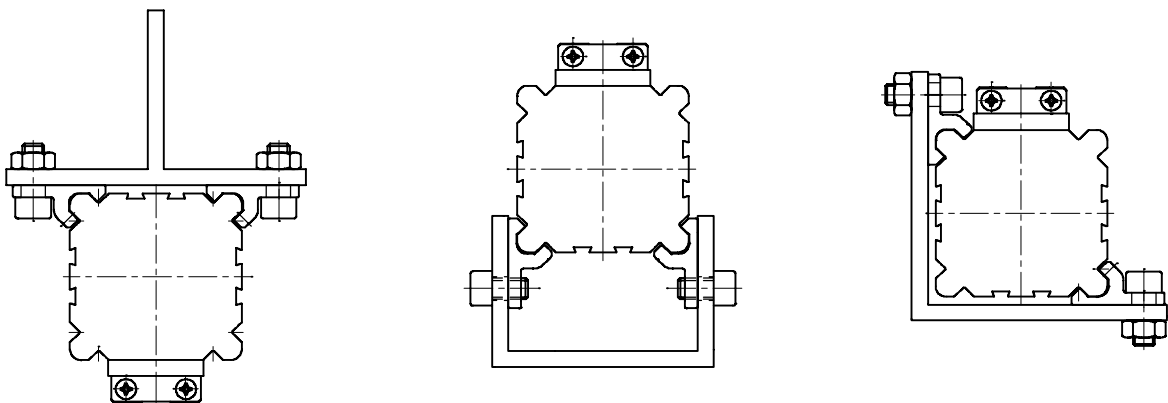



# MOUNTING ELEMENTS

for rodless cylinders



## BRIDGE CONNECTOR PB TYPE

1

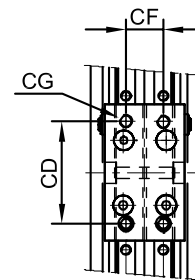
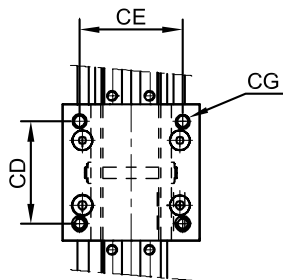
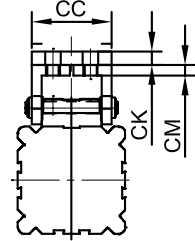
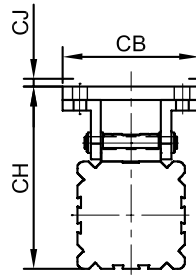
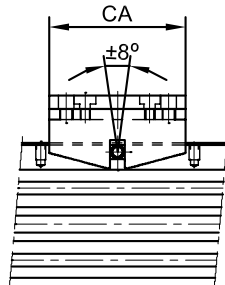

1XX5 - 0000

1XX5 - 0001

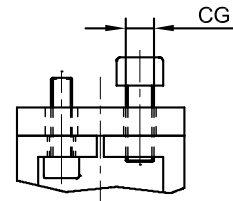
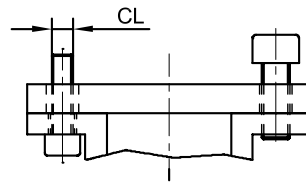

	Ø 18	Ø 25	Ø 32	Ø 40	Ø 50	Ø 63
CA	50	60	70	80	90	100
CB	41.5	50	60	80	95	120
CC	25.5	30	37	47	56	73
CD	30	40	50	60	70	80
CE	34	38	48	60	70	90
CF	9	14	16	22	30	40
CG	M5	M5	M6	M8	M8 x 20	M10
CH	54	70	86	107	123	145.5
CJ	2.5	3	3.5	4.5	4.5	5
CK	4	4	6	8	8	8
CM	4	4	6	8	8	8
CL	M4	M4	M5	M6	M6	M8
Order number for version 0000(large)	10.594S.05	10.594D.05	10.594E.05	10.594F.05	10.594G.05	10.594H.05
Order number for version 0001(small)	10.594S.06	10.594D.06	10.594E.06	10.594F.06	10.594G.06	10.594H.06

The bridge connector is used to connect to another rodless cylinder.  
The mounting connector transfers the power of the action to the guide element without any tension.

## CROSS CONNECTOR KT TYPE

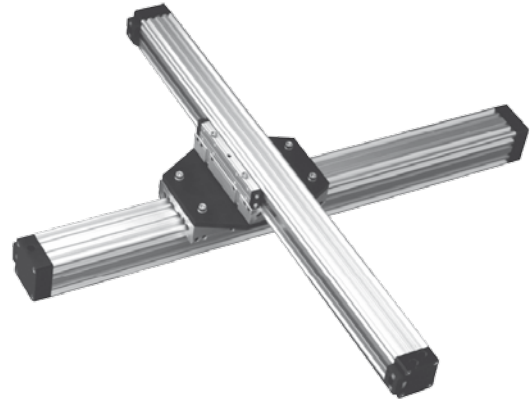
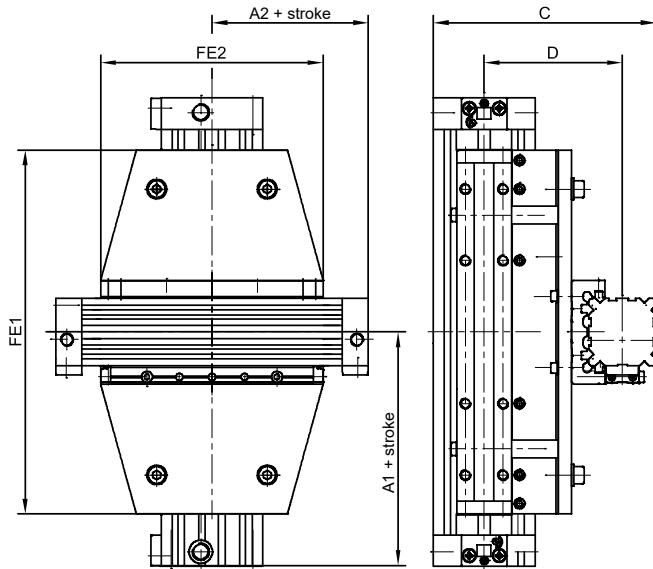

Cylinder connections	Order number	A1	A2	C	D	FE1	FE2	S
18 : 18	10.594X.1818	80	80	84	54	103	103	6
25 : 25	10.594X.2525	100	100	114	72	131	131	8
32 : 32	10.594X.3232	120	120	140	88	171	171	10
40 : 40	10.594X.4040	150	150	168	105	220	220	10
50 : 50	10.594X.5050	180	180	204	126	280	280	12
63 : 63	10.594X.6363	215	215	239	146	333	333	12

Cylinder connections	Order number	A1	A2	C	D	FE1	FE2	S
25 : 18	10.594X.2518	100	80	100	64	131	103	8
32 : 25	10.594X.3225	120	100	128	81	171	131	10
40 : 32	10.594X.4032	150	120	154	96.5	220	171	10
50 : 40	10.594X.5040	180	150	187	116.5	280	220	12
63 : 50	10.594X.6350	215	180	221.5	136	333	280	12

Cylinder connections	Order number	A1	A2	C	D	FE1	FE2	S
32 : 18	10.594X.3218	120	80	112	71	171	103	8
40 : 25	10.594X.4025	150	100	142	89.5	220	131	10
50 : 32	10.594X.5032	180	120	171	106	280	171	10
63 : 40	10.594X.6340	215	150	204.5	126.5	333	220	12

The cross connector is used to connect two rodless cylinders into a two-axis drive unit.  
The cylinders must be ordered separately.

# MOUNTING ELEMENTS

for rodless cylinders



## SIDE SUPPLY CONNECTION WITH FB MOUNTING BRACKET

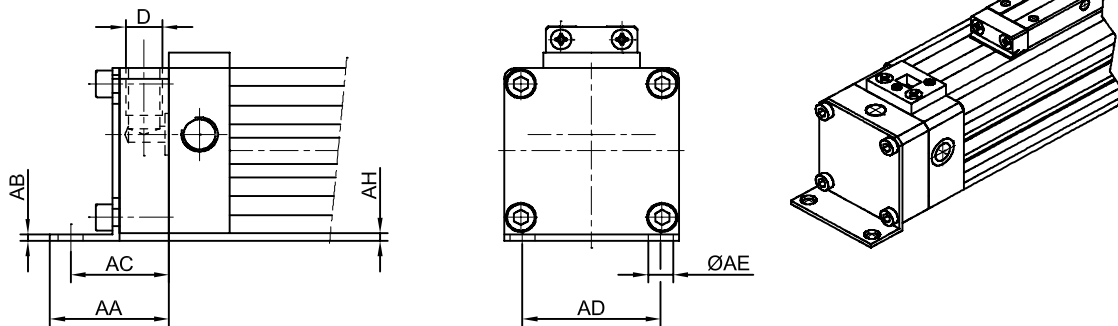

	Ø 18	Ø 25	Ø 32	Ø 40	Ø 50	Ø 63
AA	26	32	34	43	46	54
AB	2	2	2.5	2.5	3	3
AC	21	26.5	27.5	35.5	38	45
AH	2	2	3	3	3	4.5
D	M7x1 - 6	G1/8 - 7.7	G1/8 - 7.7	G1/4 - 11.7	G1/4 - 11.7	G3/8 - 11.7
Order number	On special request					

All cylinder types can be fitted with side connections on the additional front plate. The front plate can be mounted on the cylinder with mounting brackets. The mounting brackets can be mounted in 4 positions in 90° increments.

## ADAPTER AP

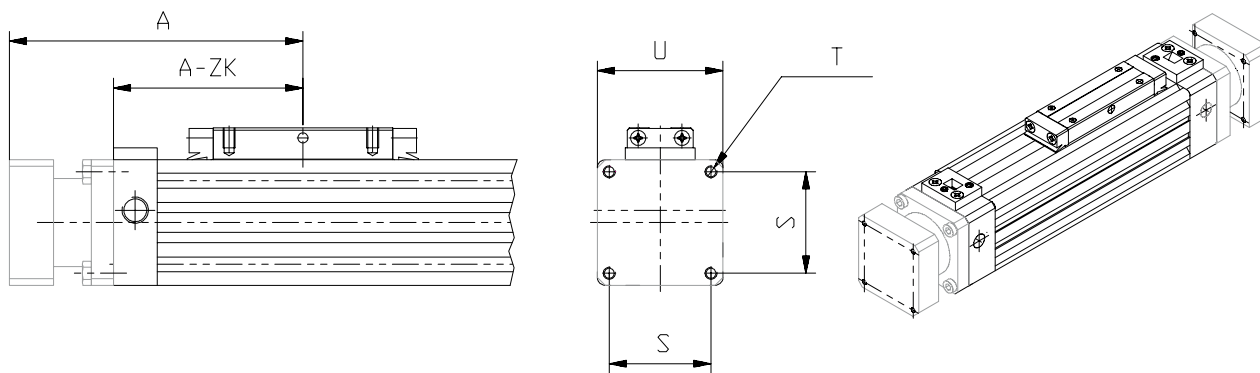

The AP adapter is used for short ZK type cylinders in order to obtain the mounting dimensions of ZS type cylinders.

	Ø 18	Ø 25	Ø 32	Ø 40	Ø 50	Ø 63
A	80	100	120	150	180	215
S						
T						
U						
Order number	Made on special request					

## AS ABSORBER MOUNTS

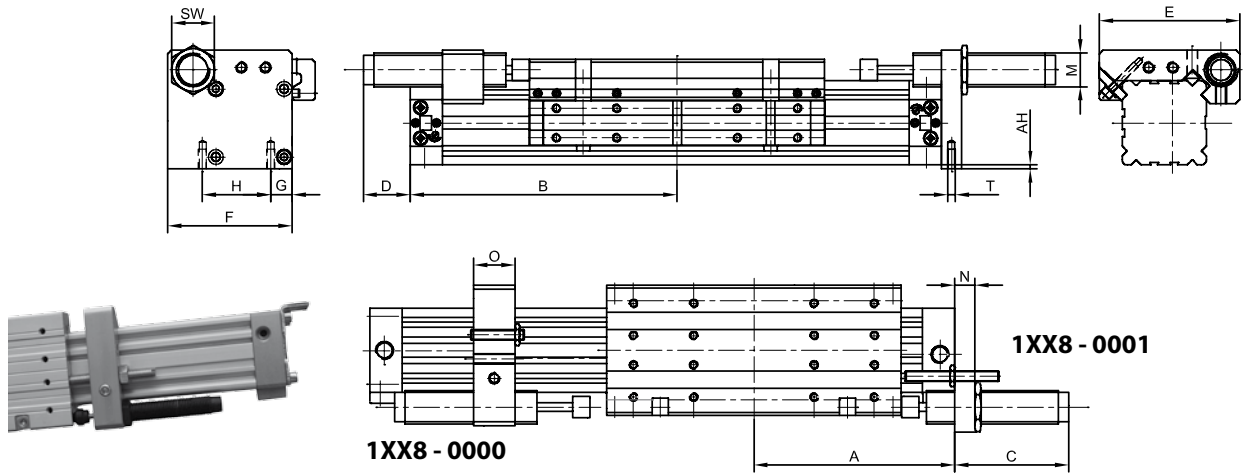

	Ø 18	Ø 25	Ø 32	Ø 40	Ø 50	Ø 63
<b>A ZF/ZFK</b>	80 / 57.5	100 / 67.5	120 / 77.5	150 / 95	180 / 105	215 / 125
<b>AH</b>	2	2	3	3	3	4.5
<b>B ZF/ZFK</b>	113 / 90.5	117.5 / 85	135.5 / 90	165 / 110	195 / 140	250 / 160
<b>C</b>	32	37	55	70	85	105
<b>D</b>	Max. 25	Max. 40	Max. 30	Max. 50	Max. 65	Max. 65
<b>E</b>	57	72	84	105	126	140
<b>F</b>	43.5	57	70	93	102	118.5
<b>G</b>	8	12.5	14.5	16	22.5	20
<b>H</b>	23.5	33	41	51	63	78
<b>M</b>	M10 x 1	M14 x 1.5		M25 x 1.5		
<b>N</b>	8	10	12	15	15	15
<b>O</b>	15	M4 - 9	M5 - 10	M6 - 15	M8 - 12	M8 - 12
<b>SW</b>	13	17		32		
<b>T</b>	M3 - 8	M4 - 10	M5 - 12	M6 - 15	M8 - 20	M8 - 20
<b>Absorber type</b>	<b>ENDINE PMX 10M-1B, 2B, 3B</b>		<b>ENDINE SPM 25 MC-1B, 2B, 3B</b>		<b>ENDINE 100MF-1B, 2B, 3B</b>	

## ORDER NUMBERS

<b>Mounting on the cylinder tube</b>	<b>10.594X.08</b>
<b>External absorber mount</b>	<b>10.594X.09</b>

Insert the cylinder diameter code in the space marked "X": S-18 mm, D-25 mm, E-32 mm, F-40 mm, G-50 mm, H-63 mm

## ORDERING PROCEDURE

In your order, please specify the name, cylinder type, order number and the number of pieces, e.g.:

**AS25 type external absorber mount for ZF25 or ZFK 25 type cylinders (without absorber) no. 10.594D.09 1 pc.**

# MOUNTING ELEMENTS

for rodless cylinders



## SENSOR MOUNTING:

1

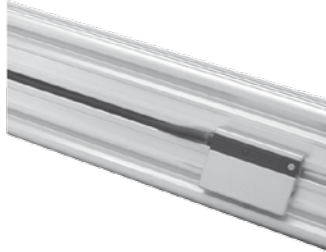

Additional bracket and cable routing for sensor type T

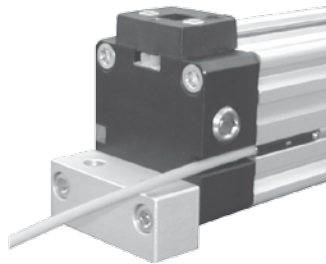

**Note:** When installing C type sensor, an opening must be provided for the cable

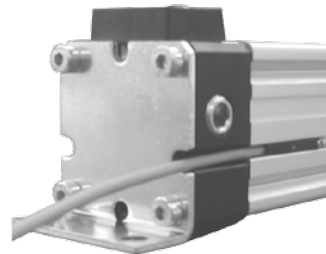

Cable routing by tensioning in FB type bracket

For rodless cylinders, the same magnetic field sensors are used as for piston rod cylinders. More information can be found on page 1.17.06.01 of this catalogue.

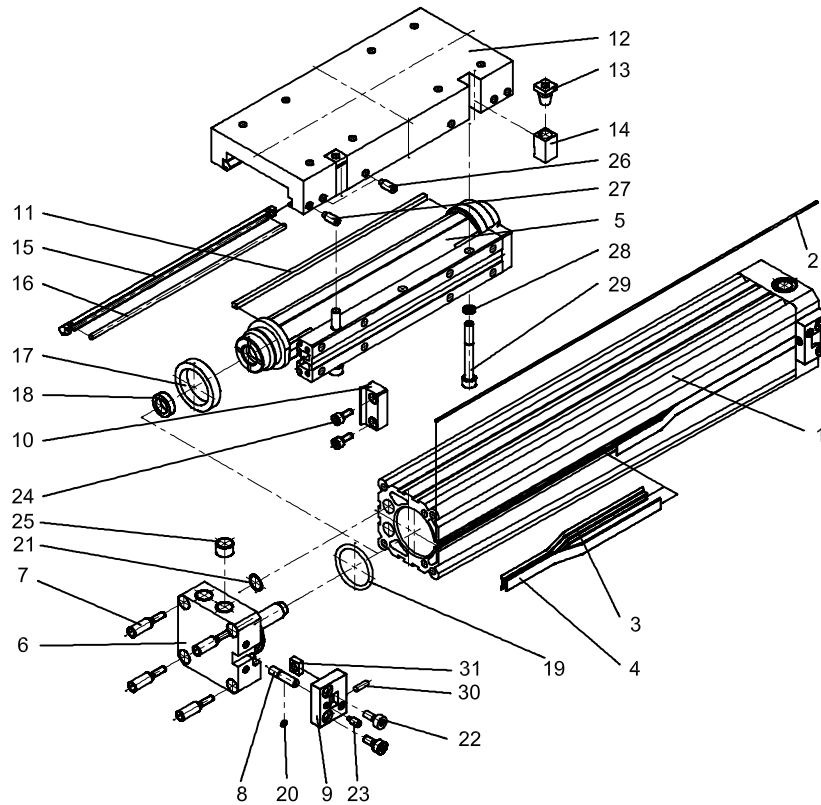

1	Profile tube	Anodised Al
2	Round section	TPU
3	Tape gasket	PA
4	Masking tape	Stainless steel
5	Slider	Anodised Al / plastic
6	Cover	Anodised Al
7	Special bolt	Galvanised steel
8	Cushioning needle	Stainless steel
9	Tape cover	Plastic
10	Front scraper	
11	Scraper	
12	Guide plate	Anodised Al
13	Tapered nut	Galvanised steel
14	Plug	Anodised Al
15	Guide pin	POM
16	Pressure rod	Stainless steel
17	Piston gasket	PU
18	Cushioning ring	NBR rubber
19	O-ring	
20	O-ring	
21	Flat gasket	Galvanised steel
22	Bolt	
23	Mounting bolt	
24	Bolt	
25	Safety bolt	
26	Mounting bolt	Oxidised steel
27	Mounting bolt	
28	Spring washer	Galvanised steel
29	Cylinder screw	
30	Mounting bolt	Oxidised steel
31	Square-head nut	Galvanised steel

# REPAIR KITS

## for rodless cylinders



1

Cylinder type	Ø 18	Ø 25	Ø 32	Ø 40	Ø 50	Ø 63
	Order numbers					
ZS	13.500S.ZS.KN	13.500D.ZS.KN	13.500E.ZS.KN	13.500F.ZS.KN	13.500G.ZS.KN	13.500H.ZS.KN
ZK	13.500S.ZK.KN	13.500D.ZK.KN	13.500E.ZK.KN	13.500F.ZK.KN	13.500G.ZK.KN	13.500H.ZK.KN
ZF	13.510S.ZF.KN	13.510D.ZF.KN	13.510E.ZF.KN	13.510F.ZF.KN	13.510G.ZF.KN	13.510H.ZF.KN
ZFF	13.510S.ZFF.KN	13.510D.ZFF.KN	13.510E.ZFF.KN	13.510F.ZFF.KN	13.510G.ZFF.KN	13.510H.ZFF.KN
ZFK	13.510S.ZFK.KN	13.510D.ZFK.KN	13.510E.ZFK.KN	13.510F.ZFK.KN	13.510G.ZFK.KN	13.510H.ZFK.KN
ZP	13.520S.ZP.KN	13.520D.ZP.KN	13.520E.ZP.KN	13.520F.ZP.KN	13.520G.ZP.KN	13.520H.ZP.KN
ZGS/ZDS	CUSTOM ORDER REPAIR KITS					
ZGK/ZDK						
ZGF/ZDF						
ZTS	CUSTOM ORDER REPAIR KITS					
ZTK						
ZTF						
Slider gasket	13.500.01					
Securing tape	13.500.02					

**Note:** in each case, for a repair kit, please specify the cylinder stroke in order to select the length of the sealing and securing (metal) tape.

### ORDERING PROCEDURE

In your order, please specify the name and diameter of the cylinder, order number and the number of pieces, e.g.:

**Repair kit for ZS rodless cylinder Ø25 no. 13.500D.ZS.KN 1 pc.**

## DESIGN FEATURES

- Rodless cylinder supply on both sides
- The cylinder speed is controlled by means of throttle and check valves
- Cylinder control without flow control causes excessive acceleration. The resulting kinetic energy can damage the cylinder and its equipment.
- For slow movements reduce the airflow rate (to reduce the movement speed to 0.05 m/s)
- Movement speed up to 2 m/s depends on the load of the pneumatic motor.

## CYLINDER CONTROL EXAMPLES:

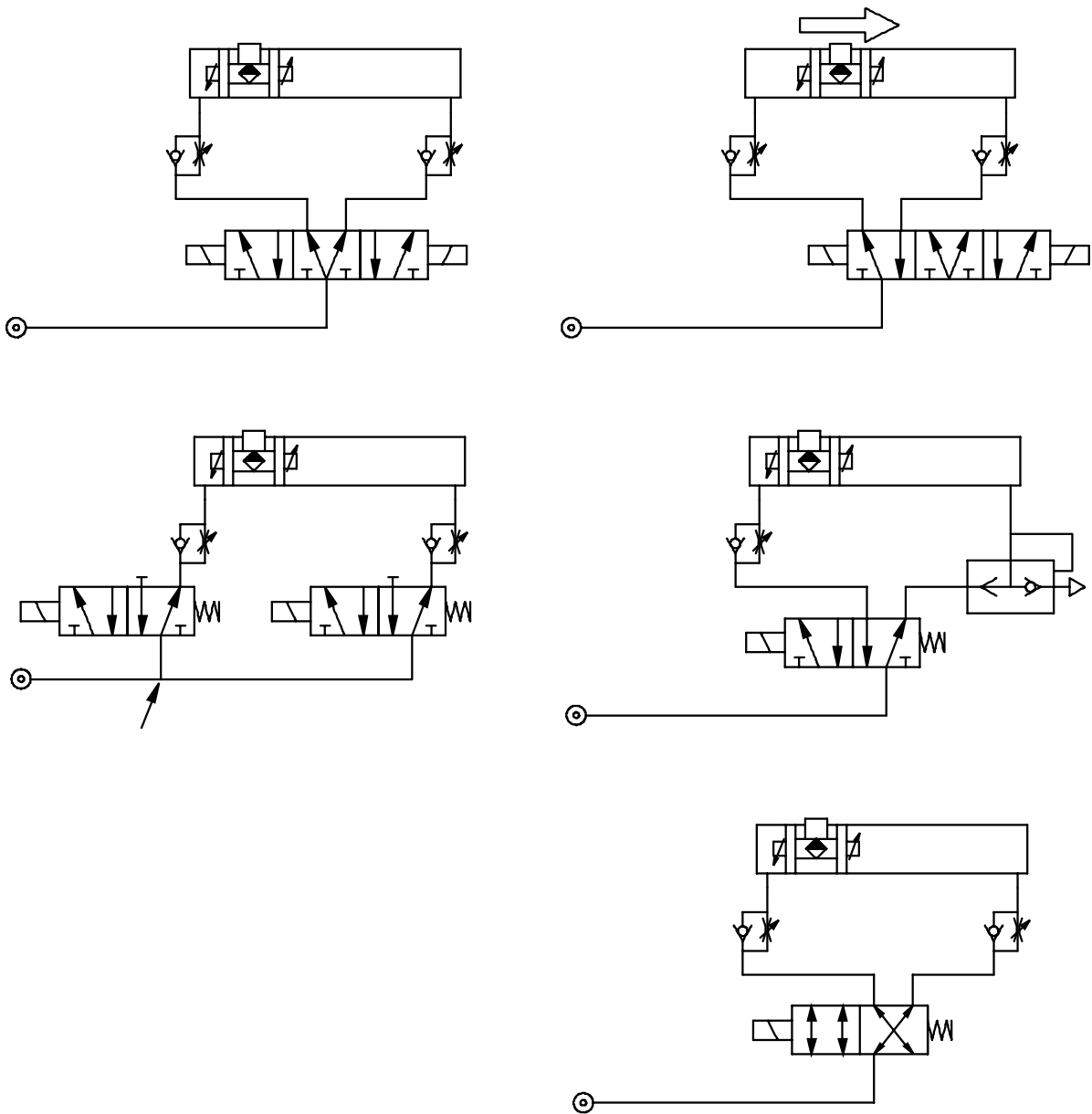



In the "PREMA" pneumatics production plant, we manufacture non-typical cylinders for individual orders. Examples of non-standard products are presented below:

## MULTI-CHAMBER CYLINDERS

The special design allows a several times higher extension force of the piston rod to be achieved. Such cylinders are composed of n-chambers, each of them equipped with a piston, so that the achieved extension force is n times greater compared to a standard cylinder. Upon request, the manufacturing of such cylinders in other combinations, such as cylinders with increased pulling force or increased double-acting force is also possible.

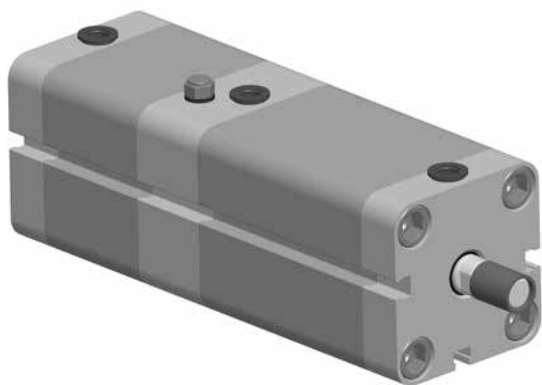
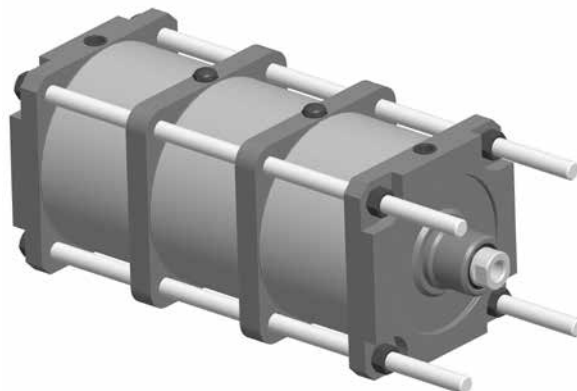

## DOUBLE STROKE CYLINDERS

Cylinders in which obtaining three positions of the piston rod is possible. Thanks to its construction, the piston rod will change the position by the stroke value of the first chamber when one of the chambers receives air supply. If we feed compressed air into the second chamber, the piston rod will complete the full cylinder stroke.

## CYLINDERS WITH A ROTATION LOCK

The main element of the cylinders with a rotation lock is a specially designed piston with a square section piston rod. Such cylinders are used in various systems where the piston rod operation is exposed to non-linear extension trajectory.



## PNEUMATIC CYLINDER with hydraulic adjustment of the piston rod extension/return speed

The principle of operation of this type of cylinders is based on the cooperation of a pneumatic cylinder with a hydraulically powered cylinder. Thus, by adjusting the knobs, we can achieve a different piston rod extension and return speed.

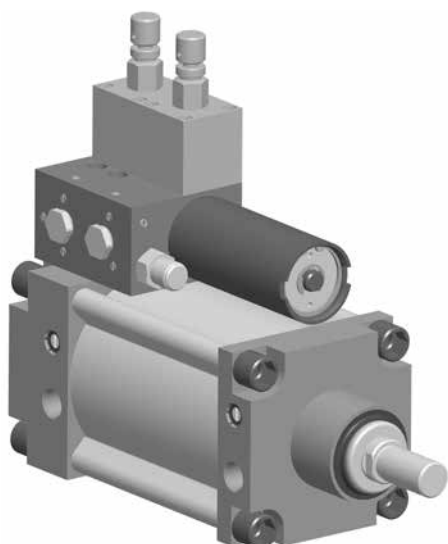

## CYLINDERS WITH STROKE ADJUSTMENT

Cylinders with stroke adjustment allow strokes of different values to be obtained thanks to special design. This is achieved by means of an adjustment screw which, combined with a suitable mechanism, ensures the stroke of the piston rod of the desired value. There are also other ways to make the cylinder, where you can obtain, for example, adjustable stroke of a pulling cylinder.

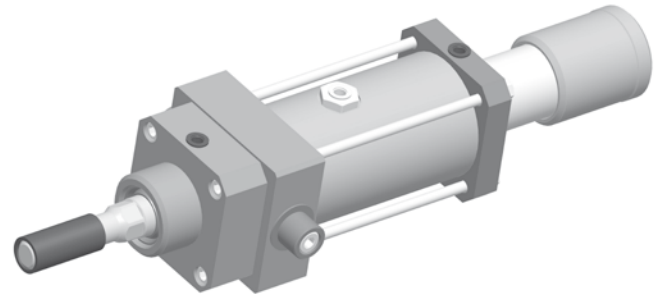

## CYLINDER CONTROLLED BY POSITIONER

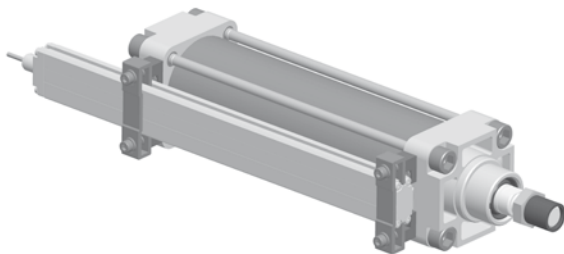

The positioner is a device for controlling linear drives. It is designed to work with single-acting and double-acting pneumatic cylinders. It enables fast and precise control of piston rod movement in the cylinder with an analogue 4-20 mA control signal. Optional communication using the Hart protocol and PROFIBUS - PA.

**All information concerning orders for special versions available  
from the Sales Department at +48 41 361 95 24**



## TECHNICAL SPECIFICATIONS

<b>Maximum operating pressure:</b>	2–8 bar
<b>Operating temperature:</b>	-20 – +80 °C
<b>Max. operating frequency:</b>	60 cycles/min
<b>Service:</b>	two-way operation
<b>Materials:</b>	
<b>Gripper jaw</b>	- stainless steel
<b>Body</b>	- aluminium alloy
<b>Pusher</b>	- chrome-plated carbon steel
<b>Piston</b>	- aluminium alloy
<b>Cover</b>	- aluminium alloy
<b>Sealing</b>	- polyurethane

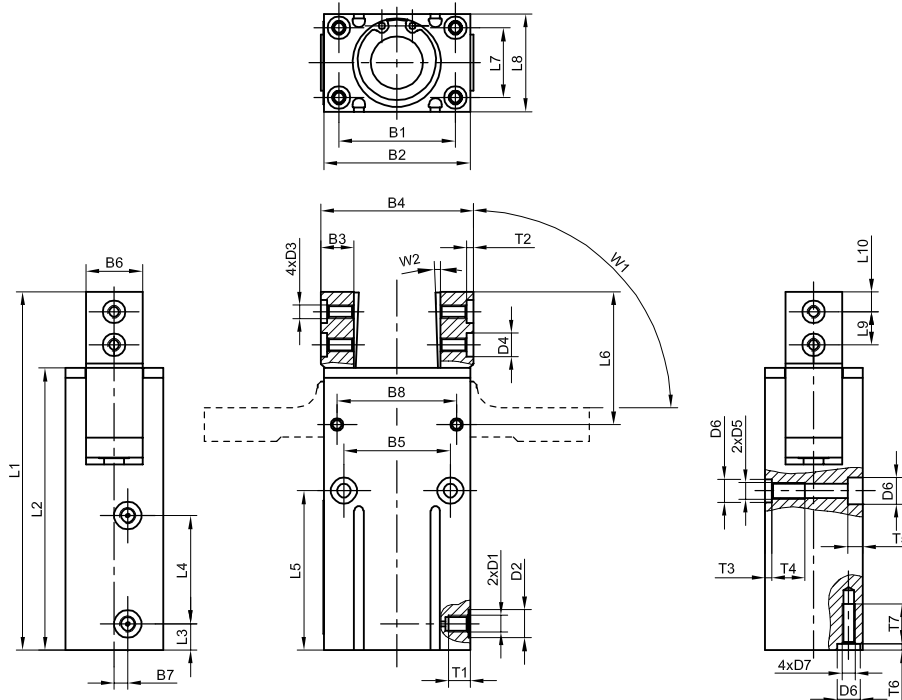
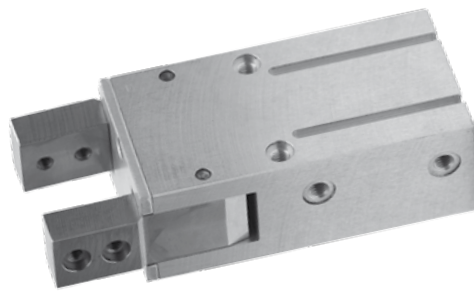
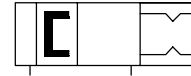

Size [mm]	B1	B2	B3	B4	B5	B6	B7	B8	D1	D2	D3	D4	D5	D6	D7	L1	L2
16	30	38	8	40	28	13	-	32	M5	8.5	M3	6	M4	6	M3	90.5	74
25	35	44	10	46	32	17	4	36	M5	8.5	M4	7	M5	7	M4	108	85
32	45	58	13	60	40	23	4	48	G1/8	15	M5	9	M6	9	M5	134	109
40	52	67	16	69	50	31	5	55	G1/8	15	M6	11	M8	11	M6	155	123

Size [mm]	L3	L4	L5	L6	L7	L8	L9	L10	T1	T2	T3	T4	T5	T6	T7	W1	W2
16	8.5	27.5	42	31	14	23	8	4	6.5	2	3.4	10	2	2	12	90	2
25	8	32	48	40	21	29.5	10	6	6.5	2	2	10	4.6	2	12	90	2
32	11	43.5	64	45	27	38	12	6	6.5	2.5	2.5	12	5.7	2.5	12	90	2
40	13.5	45	70	57	34	48	16	8	6.5	3	3	14	6.8	3	14	90	2

# CPKB SERIES

## Angle grippers



1

Size [mm]	Order number
16	31.002B.00180
25	31.002D.00180
32	31.002E.00180
40	31.002F.00180

### ORDERING PROCEDURE

In your order, please specify: name, order number and the number of pieces, e.g.:

**Angle gripper CPKB 16 mm, no. 31.002B.00180 1 pc.**

### SMI SERIES

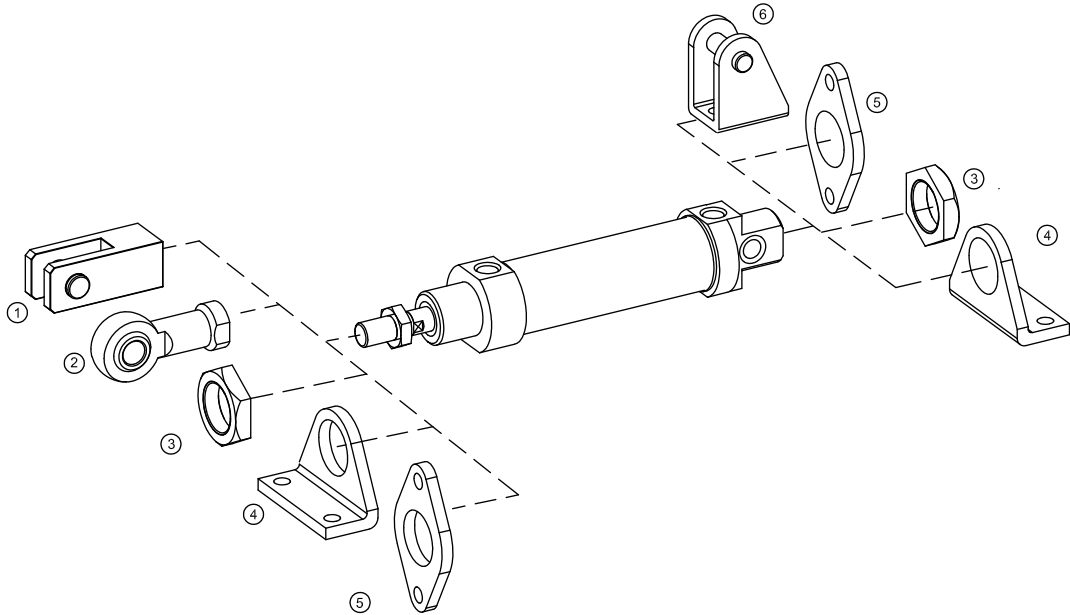

Position		1	2	3	4	5	6
Page no.		1.17.01.12	1.17.01.11	1.17.01.15	1.17.01.13	1.17.01.15	1.17.01.21
Part name		Piston rod clevis	Straight end with ball joint	Nut	Bracket	Flange	Eye with pin
Diameter D of the cylinder	12	10.007A.02.	10.014B.06.	10.007A.05.	10.007A.03.	10.007A.04.	10.007A.01.
	16						10.007A.01.01.
	20	10.007C.02.	10.014C.06.	10.007C.05.	10.007C.03.	10.007C.04.	10.007C.01.
	25	10.007D.02.	10.014E.06.				10.007C.01.01.

### STD SERIES

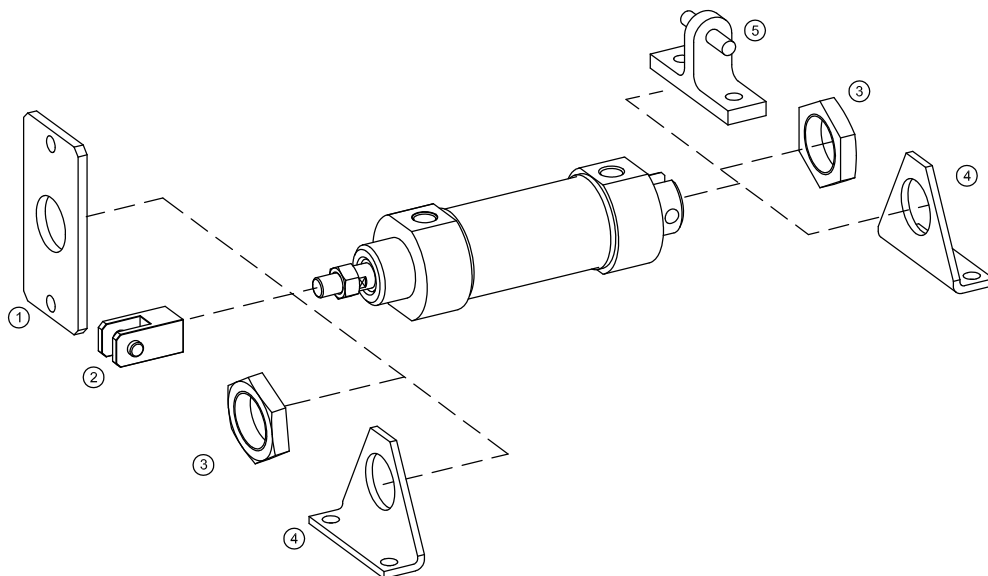

Position		1	2	3	4	5
Page no.		1.17.01.16	1.17.01.12	1.17.01.15	1.17.01.13	1.17.01.21
Part name		Flange	Piston rod clevis	Nut	Bracket	Eye with pin
Diameter D of the cylinder	32	10.011E.04.	10.011E.02.	10.011E.05.	10.011E.03.	10.011E.01.

# ACCESSORIES FOR CYLINDERS

## Mounting elements



### SCN SERIES

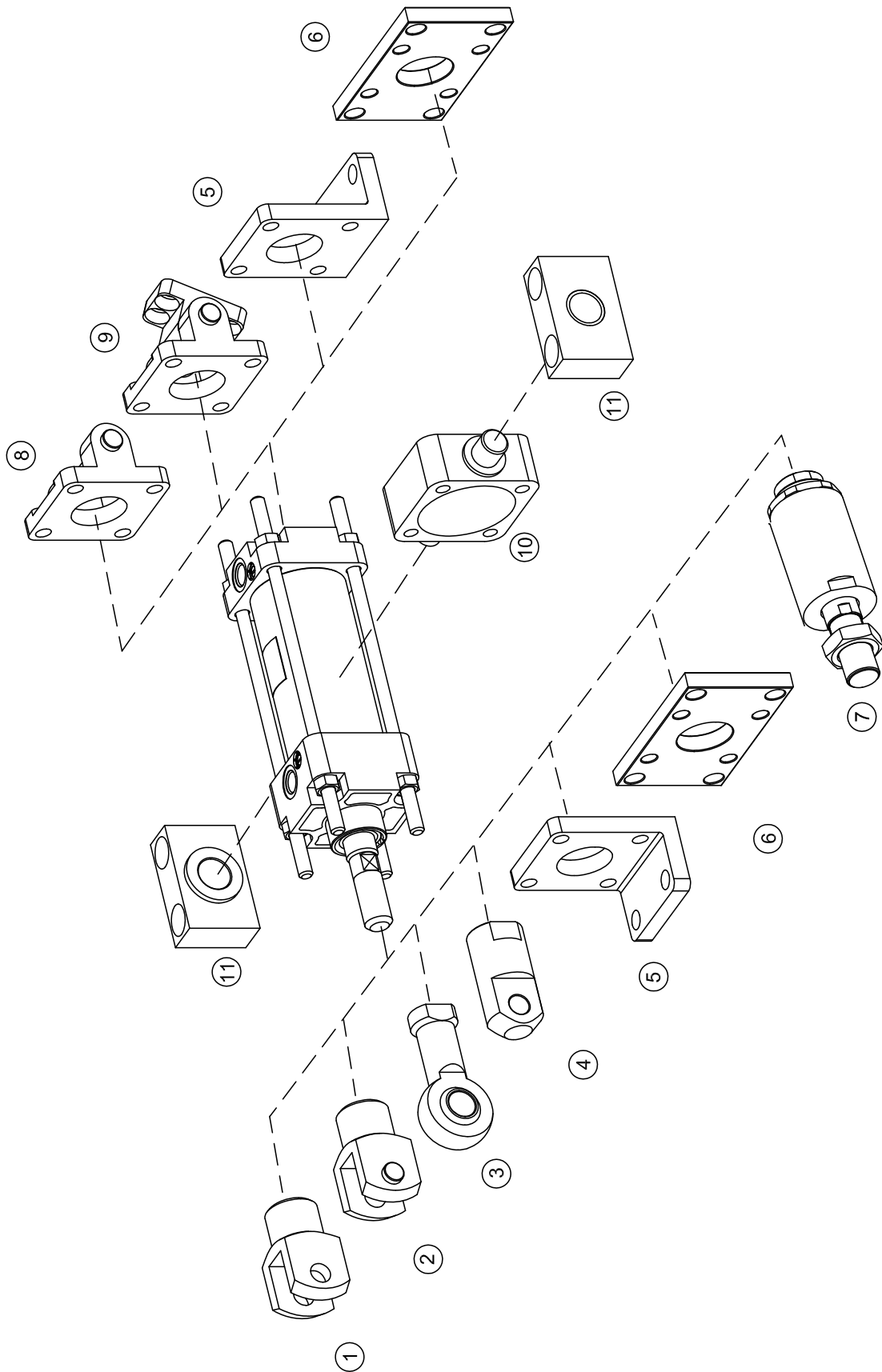

Position	1	2	3	4	5	6	7	8	9	10	11
Page no.	1.17.01.12	1.17.01.12	1.17.01.11	1.17.01.11	1.17.01.14	1.17.01.15	1.17.01.11	1.17.01.19	1.17.01.23	1.17.01.17	1.17.01.19
Part name	Piston rod clevis		Piston rod eye	Straight end	Bracket	Flange	Compensation joint	Fork	Straight eye complete	Central Trunnion	Bearing bracket for Central Trunnion
	without pin	with pin									
<b>32</b>	-	-	-	-	-	-	-	-	-	10.004E.05	10.014E.18
<b>40</b>	10.004G.07	10.004G.08	10.014H.06	10.004G.06.	10.004F.03*	10.004F.04	10.014H.08	10.004F.02*	10.004F.01.*	10.004F.05	10.014G.18
	10.004G.07	10.004G.08	10.014H.06	10.004G.06.	10.004F.03A**	10.004F.04	10.014H.08	10.004F.02.A**	10.004F.01.A**		
<b>50</b>	10.004J.07	10.004J.08	10.014K.06.	10.004J.06.	10.004G.03*	10.004G.04	10.014K.08	10.004G.02.*	10.004G.01.*	10.004H.05	10.014J.18
	10.004J.07	10.004J.08	10.014K.06.	10.004J.06.	10.004G.03A**	10.004H.04	10.014K.08	10.004H.02.*	10.004H.01.*		
<b>63</b>	10.004L.07	10.004L.08	10.014N.06.	10.004L.06.	10.004H.03*	10.004H.04	10.014L.08	10.004H.02.A**	10.004H.01.A**	10.004K.05	10.014L.18
	10.004L.07	10.004L.08	10.014N.06.	10.004L.06.	10.004H.03A**	10.004J.04.	10.014L.08	10.004J.02.*	10.004J.01.*		
<b>80</b>	10.004L.07	10.004L.08	10.014N.06.	10.004L.06.	10.004K.03*	10.004K.04.	10.014L.08	10.004K.02.*	10.004K.01.*	10.004M.05	10.014N.18
	10.004L.07	10.004L.08	10.014N.06.	10.004L.06.	10.004K.03A**	10.004L.04.	10.014L.08	10.004K.02.A**	10.004K.01.A**		
<b>100</b>	10.004L.07	10.004L.08	10.014N.06.	10.004L.06.	10.004L.03.*	10.004L.04.	10.014M.08	10.004L.02.*	10.004L.01.*	10.004N.05	10.014N.18
	10.004L.07	10.004L.08	10.014N.06.	10.004L.06.	10.004L.03.*	10.004M.04.	10.014M.08	10.004L.02.A**	10.004L.01.A**		
<b>125</b>	10.004N.07.	10.004N.08.	10.014N.06.	10.014N.06.	10.004M.03.*	10.004M.04.	10.014M.08	10.004M.02.*	10.004M.01.*	10.004N.05	10.014N.18
	10.004N.07.	10.004N.08.	10.014N.06.	10.014N.06.	10.004M.03.*	10.004M.04.	10.014M.08	10.004M.02.A**	10.004M.01.A**		
<b>160</b>	10.004N.07.	10.004N.08.	10.014N.06.	10.014N.06.	10.004N.03.*	10.004N.04.	10.014M.08	10.004N.02.*	10.004N.01.*	10.004N.05	10.014N.18
	10.004N.07.	10.004N.08.	10.014N.06.	10.014N.06.	10.004N.03.*	10.004N.04.	10.014M.08	10.004N.02.A**	10.004N.01.A**		
<b>200</b>	10.004N.07.	10.004N.08.	10.014N.06.	10.014N.06.	10.004N.03.*	10.004N.04.	10.014M.08	10.004N.02.*	10.004N.01.*	10.004N.05	10.014N.18
	10.004N.07.	10.004N.08.	10.014N.06.	10.014N.06.	10.004N.03.*	10.004N.04.	10.014M.08	10.004N.02.A**	10.004N.01.A**		

\* made of cast iron  
\*\* made of aluminium alloy



# ACCESSORIES FOR CYLINDERS

## Mounting elements



### STK SERIES

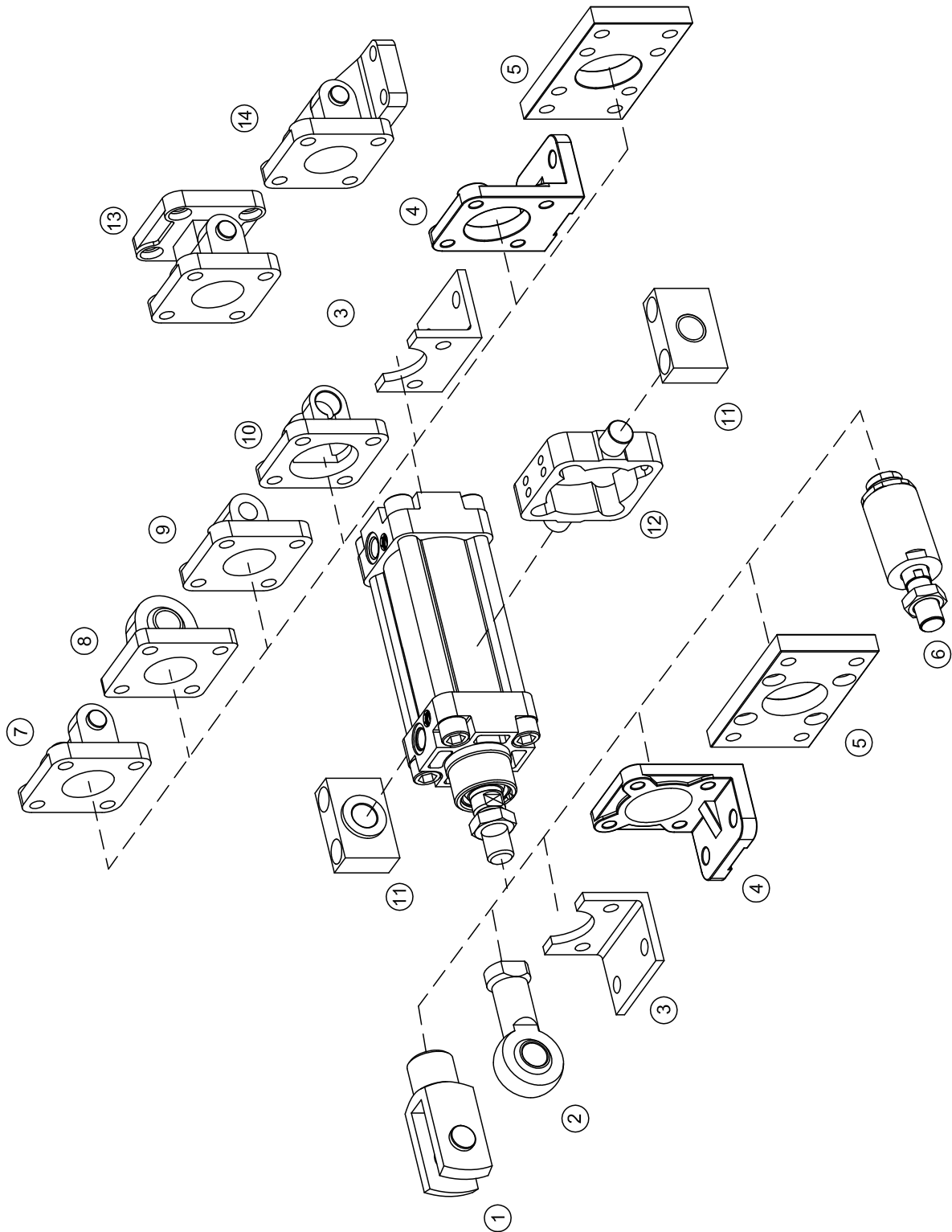

Position	1	2	3	4	5	6	7	8	9	10	11	12	13	14	
Page no.	1.17.01.12	1.17.01.11	1.17.01.13	1.17.01.14	1.17.01.15	1.17.01.11	1.17.01.20	1.17.01.23	1.17.01.22	1.17.01.20	1.17.01.19	1.17.01.18	1.17.01.22	1.17.01.23	
Part name	Piston rod clevis	Straight end with ball joint	Bracket	High bracket	Flange	Compensation joint	Fork	Straight eye with ball joint	Straight eye	Fork for pin with safety	Bearing bracket for Central Trunnion	Central Trunnion	Straight eye complete	Angle eye complete	
Diameter D of the cylinder	32	10.014E.07. 10.014E.06.	10.014E.03. 10.014E.04.	10.014E.13.A 10.014E.04.	10.014E.04. 10.014F.04.	10.014E.08 10.014F.08	10.014E.02.* 10.014E.02.A**	10.014E.16. 10.014F.16.	10.014E.01.1.* 10.014E.01.1.A**	10.014E.23. 10.014F.23.	10.014E.18. 10.014G.18.	10.014E.19. 10.014F.19.	10.014E.01.* 10.014E.01.A**	10.014E.15.* 10.014E.15.A**	
	40	10.014F.07. 10.014F.06.	10.014F.03. 10.014F.04.	10.014F.13.A 10.014F.04.	10.014F.04. 10.014F.08.	10.014F.08 10.014H.08	10.014F.02.* 10.014F.02.A**	10.014F.16. 10.014G.16.	10.014F.01.1.* 10.014F.01.1.A**	10.014F.23. 10.014G.23.	10.014G.18. 10.014H.18.	10.014F.19. 10.014G.19.	10.014F.01.* 10.014F.01.A**	10.014F.15.* 10.014F.15.A**	
	50	10.014H.07. 10.014H.06.	10.014G.03. 10.014H.04.	10.014G.03. 10.014H.04.	10.014G.13.A 10.014H.04.	10.014G.04. 10.014H.08.	10.014G.08 10.014H.08	10.014G.02.* 10.014G.02.A**	10.014G.16. 10.014H.16.	10.014G.01.1.* 10.014G.01.1.A**	10.014G.23. 10.014H.23.	10.014G.19. 10.014H.19.	10.014G.01.* 10.014G.01.A**	10.014G.15.* 10.014G.15.A**	
	63	10.014H.07. 10.014H.06.	10.014H.03. 10.014H.04.	10.014H.03. 10.014H.04.	10.014H.13.A 10.014H.04.	10.014H.04. 10.014K.08.	10.014H.08 10.014K.08	10.014H.02.* 10.014H.02.A**	10.014H.16. 10.014J.16.	10.014H.01.1.* 10.014H.01.1.A**	10.014H.23. 10.014J.23.	10.014H.19. 10.014J.19.	10.014H.01.* 10.014J.01.*	10.014H.15.* 10.014J.15.*	
	80	10.014K.07. 10.014K.06.	10.014J.03. 10.014K.04.	10.014J.03. 10.014K.04.	10.014J.13.A 10.014K.04.	10.014J.04. 10.014K.08.	10.014K.08 10.014K.08	10.014J.02.* 10.014J.02.A**	10.014J.16. 10.014K.16.	10.014J.01.1.* 10.014J.01.1.A**	10.014J.23. 10.014K.23.	10.014J.19. 10.014L.18.	10.014J.19. 10.014K.19.	10.014J.01.* 10.014K.01.*	10.014J.15.* 10.014K.15.*
	100	10.014K.07. 10.014K.06.	10.014K.03. 10.014K.04.	10.014K.03. 10.014K.04.	10.014K.13.A 10.014K.04.	10.014K.04. 10.014K.08.	10.014K.08 10.014K.08	10.014K.02.* 10.014K.02.A**	10.014K.16. 10.014L.16.	10.014K.01.1.* 10.014K.01.1.A**	10.014K.23. 10.014L.18.	10.014K.19. 10.014L.18.	10.014K.19. 10.014L.18.	10.014K.01.* 10.014K.01.A**	10.014K.15.* 10.014L.15.*

\* made of cast iron  
\*\* made of aluminium alloy

# ACCESSORIES FOR CYLINDERS

## Mounting elements



### SSI, SPT\*\*\* SERIES

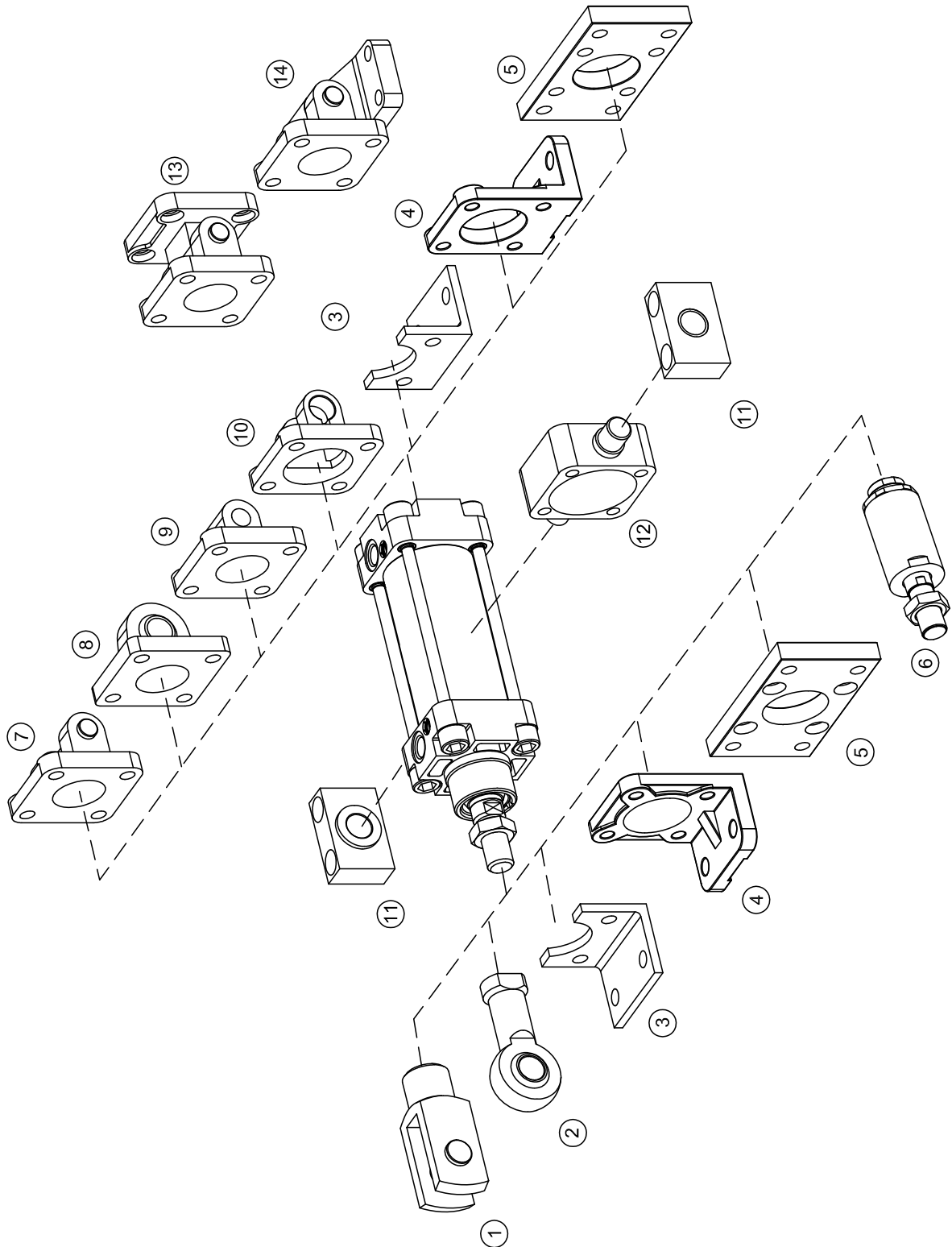

Position	1	2	3***	4***	5***	6***	7***	8***	9***	10	11	12***	13***	14***
<b>Catalogue page no.</b>	1.17.01.12	1.17.01.11	1.17.01.13	1.17.01.14	1.17.01.16	1.17.01.11	1.17.01.20	1.17.01.23	1.17.01.22	1.17.01.20	1.17.01.19	1.17.01.17	1.17.01.22	1.17.01.24
<b>Part name</b>	<b>Piston rod clevis</b>	<b>Piston rod eye</b>	<b>MS1 bracket</b>	<b>High bracket</b>	<b>Flange</b>	<b>Compensation joint</b>	<b>Fork</b>	<b>Straight eye with ball joint</b>	<b>Straight eye</b>	<b>Fork for pin with safety</b>	<b>Bearing bracket for Central Trunnion</b>	<b>Central Trunnion</b>	<b>Straight eye complete</b>	<b>Angle eye complete</b>
<b>32</b>	10.014E.07.	10.014E.06.	10.014E.03.	10.014E.13.A	10.014E.04.	10.014E.08	10.014E.02.* 10.014E.02.A**	10.014E.16. 10.014E.01.1.A**	10.014E.01.1.* 10.014E.01.1.A**	10.014E.23.	10.014E.18.	10.014E.05. xxxx	10.014E.01.* 10.014E.01.A**	10.014E.15.* 10.014E.15.A**
<b>40</b>	10.014F.07.	10.014F.06.	10.014F.03.	10.014F.13.A	10.014F.04.	10.014F.08	10.004F.02.* 10.004F.02.A**	10.014F.16.	10.014F.01.1.* 10.014F.01.1.A**	10.014F.23.	10.014G.18.	10.014F.05. xxxx	10.014F.01.* 10.014F.01.A**	10.014F.15.* 10.014F.15.A**
<b>50</b>	10.014H.07.	10.014H.06.	10.014G.03.	10.014G.13.A	10.014G.04.	10.014H.08	10.004G.02.* 10.004G.02.A**	10.014G.16.	10.014G.01.1.* 10.014G.01.1.A**	10.014G.23.		10.014G.05. xxxx	10.014G.01.* 10.014G.01.A**	10.014G.15.* 10.014G.15.A**
<b>63</b>			10.014H.03.	10.014H.13.A	10.014H.04.	10.014H.08	10.004H.02.* 10.004H.02.A**	10.014H.16.	10.014H.01.1.* 10.014H.01.1.A**	10.014H.23.		10.014H.05. xxxx	10.014H.01.* 10.014H.01.A**	10.014H.15.* 10.014H.15.A**
<b>83</b>			10.014J.03.	10.014J.13.A	10.014J.04.	10.014K.08	10.004J.02.* 10.004J.02.A**	10.014J.16.	10.014J.01.1.* 10.014J.01.1.A**	10.014J.23.	10.014J.18.	10.014J.05. xxxx	10.014J.01.* 10.014J.01.A**	10.014J.15.* 10.014J.15.A**
<b>100</b>	10.014K.07.	10.014K.06.	10.014K.03.	10.014K.13.A	10.014K.04.	10.014K.08	10.004K.02.* 10.004K.02.A**	10.014K.16.	10.014K.01.1.* 10.014K.01.1.A**	10.014K.23.		10.014K.05. xxxx	10.014K.01.* 10.014K.01.A**	10.014K.01.* 10.014K.01.A**
<b>125</b>	10.014L.07.	10.014L.06.	10.014L.03.	10.014L.13.A	10.014L.04.	10.014L.08	10.004L.02.* 10.004L.02.A**	10.014L.16.	10.014L.01.1.* 10.014L.01.1.A**	10.014L.23.	10.014L.18.	10.014L.05. xxxx	10.014L.01.* 10.014L.01.A**	10.014L.15.* 10.014L.15.A**
<b>160</b>			10.014M.03.	10.014M.13.A	10.014M.04.	10.014M.08	10.004M.02.* 10.004M.02.A**	-	10.014M.01.1.* 10.014M.01.1.A**	-		10.014M.05. xxxx	10.014M.01.* 10.014M.01.A**	10.014M.15.* 10.014M.15.A**
<b>200</b>	10.014N.07.	10.014N.06.	10.014N.03.	10.014N.13.A	10.014N.04.	10.014M.08	10.004N.02.* 10.004N.02.A**	-	10.014N.01.1.* 10.014N.01.1.A**	-	10.014N.18.	10.014N.05. xxxx	10.014N.01.* 10.014N.01.A**	10.014N.15.* 10.014N.15.A**
<b>250</b>	10.014P.07.	10.014P.06.	-	-	-	10.014P.08	10.014P.02.*	-	10.014P.01.1.*	-	10.014P.18.	10.014P.05. xxxx	10.014P.01.*	-
<b>320</b>	-	10.014R.06.	-	-	-	-	10.014R.02.*	-	-	-	-	-	-	-

Diameter D of the cylinder

\* made of cast iron  
 \*\* made of aluminium alloy  
 \*\*\* mounting elements for SPT cylinders

# ACCESSORIES FOR CYLINDERS

## Mounting elements



### STE SERIES

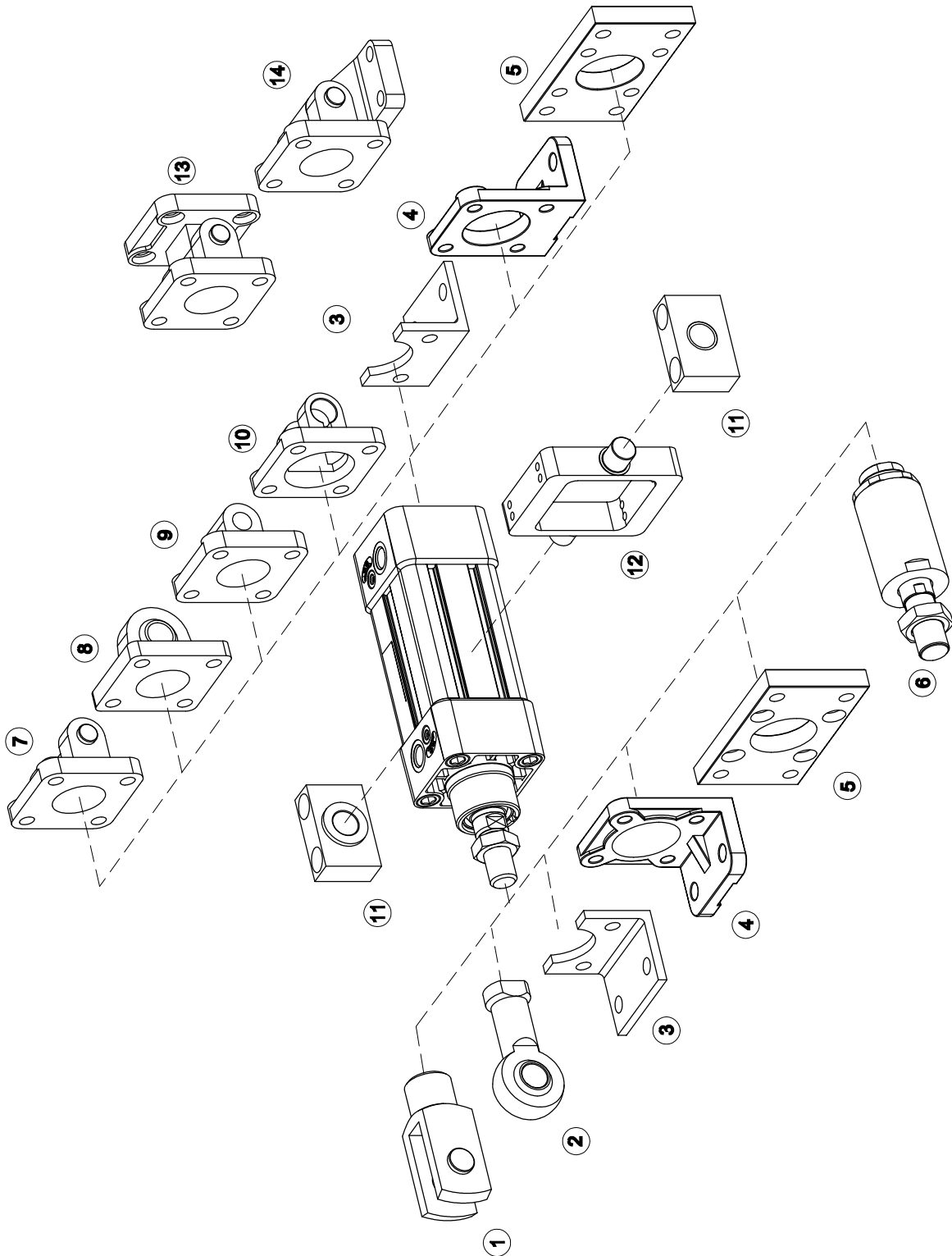

Position	1	2	3	4	5	6	7	8	9	10	11	12	13	14
<b>Catalogue page no.</b>	1.17.01.12	1.17.01.11	1.17.01.13	1.17.01.14	1.17.01.16	1.17.01.11	1.17.01.19	1.17.01.23	1.17.01.22	1.17.01.20	1.17.01.19	1.17.01.18	1.17.01.22	1.17.01.24
<b>Part name</b>	<b>Piston rod clevis</b>	<b>Straight end with ball joint</b>	<b>Bracket</b>	<b>High bracket</b>	<b>Flange</b>	<b>Compensation joint</b>	<b>Fork</b>	<b>Straight eye with ball joint</b>	<b>Straight eye</b>	<b>Fork for pin with safety</b>	<b>Bearing bracket for Central Trunnion</b>	<b>Central Trunnion</b>	<b>Straight eye complete</b>	<b>Angle eye complete</b>
<b>Diameter D of the cylinder</b>														
<b>32</b>	10.014E.07.	10.014E.06.	10.014E.03.	10.014E.13.A	10.014E.04.	10.014E.08	10.014E.02.* 10.014E.02.A**	10.014E.16.	10.014E.01.1.* 10.014E.01.1.A**	10.014E.23.	10.014E.18.	10.014E.20.	10.014E.01.* 10.014E.01.A**	10.014E.15.* 10.014E.15.A**
<b>40</b>	10.014F.07.	10.014F.06.	10.014F.03.	10.014F.13.A.	10.014F.04.	10.014F.08	10.004F.02.* 10.004F.02.A**	10.014F.16.	10.014F.01.1.* 10.014F.01.1.A**	10.014F.23.		10.014F.20.	10.014F.01.* 10.014F.01.A**	10.014F.15.* 10.014F.15.A**
<b>50</b>			10.014G.03.	10.014G.13.A	10.014G.04.	10.014H.08	10.004G.02.* 10.004G.02.A**	10.014G.16.	10.014G.01.1.* 10.014G.01.1.A**	10.014G.23.		10.014G.20.	10.014G.01.* 10.014G.01.A**	10.014G.15.* 10.014G.15.A**
<b>63</b>	10.014H.07.	10.014H.06.	10.014H.03.	10.014H.13.A	10.014H.04.	10.014H.08	10.004H.02.* 10.004H.02.A**	10.014H.16.	10.014H.01.1.* 10.014H.01.1.A**	10.014H.23.		10.014H.20.	10.014H.01.* 10.014H.01.A**	10.014H.15.* 10.014H.15.A**
<b>80</b>			10.014J.03.	10.014J.13.A	10.014J.04.	10.014K.08	10.004J.02.* 10.004J.02.A**	10.014J.16.	10.014J.01.1.* 10.014J.01.1.A**	10.014J.23.	10.014J.18.	10.014J.20.	10.014J.01.* 10.014J.01.A**	10.014J.15.* 10.014J.15.A**
<b>100</b>	10.014K.07.	10.014K.06.	10.014K.03.	10.014K.13.A	10.014K.04.	10.014K.08	10.004K.02.* 10.004K.02.A**	10.014K.16.	10.014K.01.1.* 10.014K.01.1.A**	10.014K.23.	10.014L.18.	10.014K.20.	10.014K.01.* 10.014K.01.A**	10.014K.01.* 10.014K.01.A**

\* made of cast iron  
\*\* made of aluminium alloy

# ACCESSORIES FOR CYLINDERS

## Mounting elements



### SKP SERIES

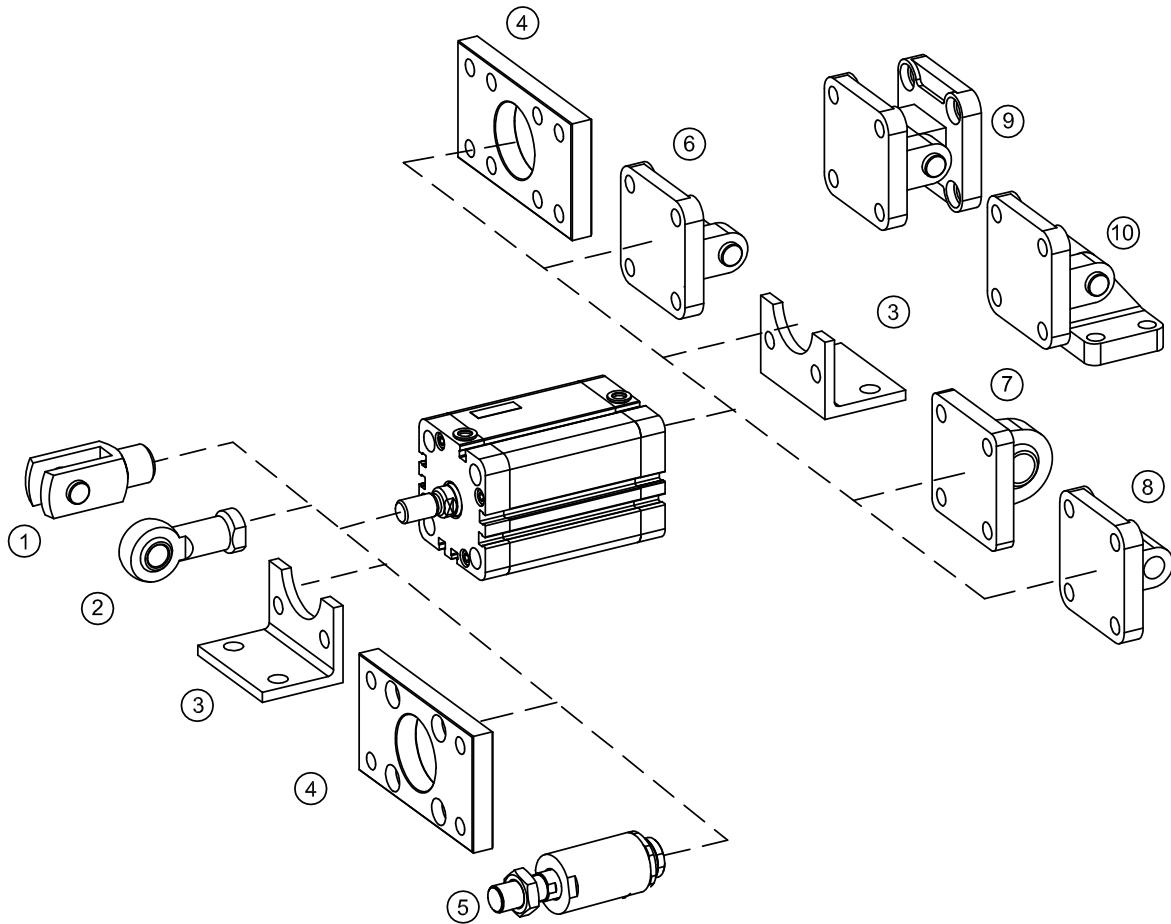

Position	1	2	3	4	5	6	7	8	9	10	
Catalogue page no.	1.17.01.12	1.17.01.11	1.17.01.13	1.17.01.16	1.17.01.11	1.17.01.20	1.17.01.22	1.17.01.23	1.17.01.22	1.17.01.24	
Part name	Piston rod clevis	End with ball joint	Bracket	Flange	Compensation joint	Fork	Straight eye	Straight eye with ball joint	Straight eye complete	Angle eye complete	
Diameter D of the cylinder	12	-	10.014B.06.	-	-	10.014B.08	-	-	-	-	
	16	-	10.014C.06.	-	-	10.014C.08	-	-	-	-	
	20	10.014E.07.	10.014E.06.	-	-	10.014E.08	-	-	-	-	
	25			-	-	10.014E.08	-	-	-	-	
	32	10.014F.07.	10.014F.06.	10.014E.03.	10.014E.04.	10.014E.08	10.014E.02.	10.014E.01.	10.014E.16.	10.014E.01.	10.014E.15.
	40			10.014F.03.	10.014F.04.	10.014E.08	10.014F.02.	10.014F.01.	10.014F.16.	10.014F.01.	10.014F.15.
	50	10.014H.07.	10.014H.06.	10.014G.03.	10.014G.04.	10.014F.08	10.014G.02.	10.014G.01.	10.014G.16.	10.014G.01.	10.014G.15.
	63			10.014H.03.	10.014H.04.	10.014F.08	10.014H.02.	10.014H.01.	10.014H.16.	10.014H.01.	10.014H.15.
	80	10.014H.07.	10.014H.06.	10.014J.03.	10.014J.04.	10.014H.08	10.014J.02.	10.014J.01.	10.014J.16.	10.014J.01.	10.014J.15.
	100			10.014K.03.	10.014K.04.	10.014H.08	10.014K.02.	10.014K.01.	10.014K.16.	10.014K.01.	10.014K.15.

### STRAIGHT END - FOR THE SCN SERIES

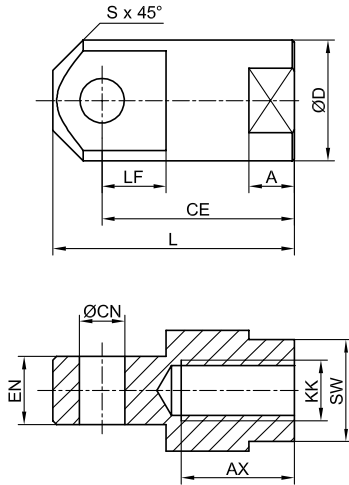

Dimensions											Order number
A	AX	ØCN	ØD	CE	KK	L	LF	EN	S	SW	
12	30	12	32	51	M16x1.5	64	17	18	8	27	10.004G.06.
16	36	16	35	63	M20x1.5	80	22	22	10	30	10.004J.06.
20	50	20	45	85	M27x2	105	27	30	12	36	10.004L.06.
25	70	25	60	115	M36x2	140	34	40	17.5	50	10.004N.06.

### PISTON ROD EYE - FOR SERIES SCN, SMI, STK, SSI, SPT, STE, SKP

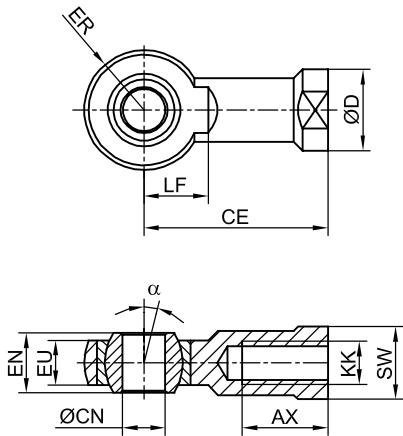

Dimension [mm]											Order number
AX	CE	ØCN	ØD	EU	EN	ER	KK	LF	SW	α°	
12	30	6	13	6.8	9	10	M6	11	11	13	10.014B.06.
16	36	8	16	9	12	12	M8	13	14	13	10.014C.06.
20	43	10	19	10.5	14	14	M10x1.25	15	17	13	10.014E.06.
22	50	12	22	12	16	16	M12x1.25	17	19	13	10.014F.06.
28	64	16	27	15	21	21	M16x1.5	22	22	15	10.014H.06.
33	77	20	34	18	25	25	M20x1.5	26	30	15	10.014K.06.
51	110	30	50	25	37	35	M27x2	36	41	15	10.014L.06.
56	125	35	58	28	43	50	M36x2	41	50	15	10.014N.06.
60	142	40	73	33	49	55	M42x2	46	65	14	10.014P.06.
68	160	50	75	45	64	64	M48x2	59	66	12	10.014R.06.

Note: material: head - alloy steel.

### COMPENSATION CONNECTOR - FOR SERIES SCN, STK, SSI, SPT, STE, SKP

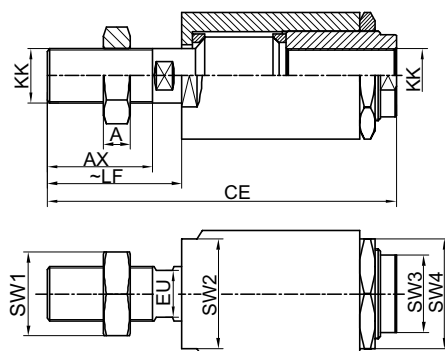

Dimension [mm]										Order number
A	AX	CE	EU	KK	LF	SW1	SW2	SW3	SW4	
-	10	31	6	M6x1	14	-	14	8.5	13	10.014B.08
-	20	53	8	M8x1.25	24	-	19	12.5	17	10.014C.08
-	20	60	14	M10x1.25	25	-	32	22	30	10.014E.08
-	24	64	14	M12x1.25	29	-	32	22	30	10.014F.08
-	32	94	22	M16x1.5	40	-	45	32	41	10.014H.08
10	40	122	18	M20x1.5	50	30	41	30	41	10.014K.08
14	54	148	24	M27x2	54	41	55	32	55	10.014L.08
18	72	251	36	M36x2	91	55	75	50	75	10.014M.08
21	82	270	36	M42x2	105	65	65	60	85	10.014P.08



# ACCESSORIES FOR CYLINDERS

## Mounting elements



### PISTON ROD CLEVIS - FOR SERIES STK, SSI, STE, SKP

Fig. 1.

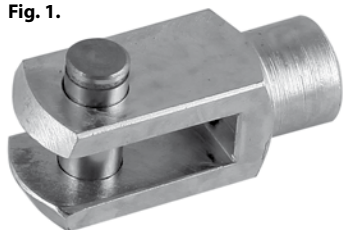
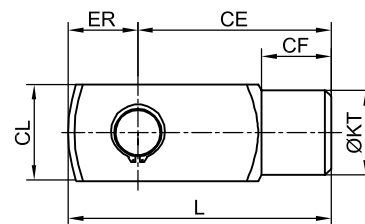
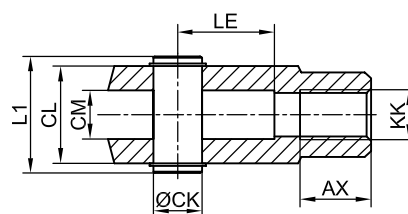

Fig. 2.



Dimension [mm]												Order number
AX	CE	CF	ØCK	CL	CM	L	L1	LE	KK	ØKT	ER	
20	40	15	10	20	10	55	25.5	20	M10×1.25	18	15	10.014E.07.
22	48	17	12	24	12	65.5	30	24	M12×1.25	20	17.5	10.014F.07.
28	64	23	16	32	16	83	38.6	32	M16×1.5	28	23	10.014H.07.
33	80	29	20	40	20	109.5	47.6	40	M20×1.5	36	29.5	10.014K.07.
51	110	46	30	55	30	152	66	54	M27×2	50	42	10.014L.07.
56	144	51	35	69	35	198	82.5	72	M36×2	64	54	10.014N.07.
60	168	55	40	85	40	245	98.5	84	M42×2	76	77	10.014P.07.

Note: material - carbon steel.



### PISTON ROD CLEVIS - FOR SERIES SMI, STD

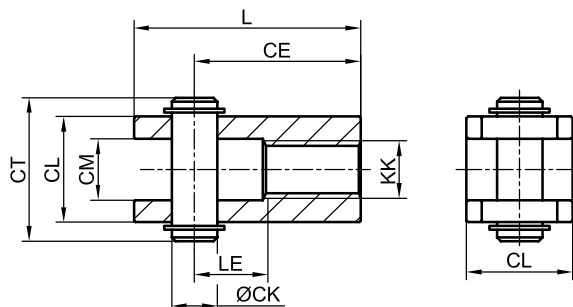
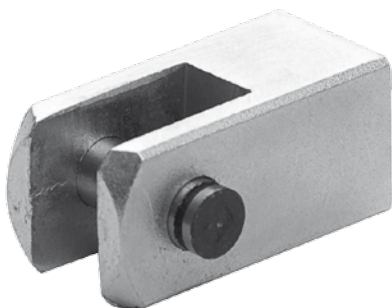

Dimension [mm]								Order number
CE	ØCK	CL	CM	CT	KK	L	LE	
24	6	12	6	17	M6	31	12	10.007A.02
32	8	16	8	21	M8	42	16	10.007C.02
40	10	20	10	25	M10×1.25	52	20	10.007D.02
22	6	14	8.1	28	M8×1	30	9	10.011E.02.

### PISTON ROD CLEVIS - FOR SCN SERIES

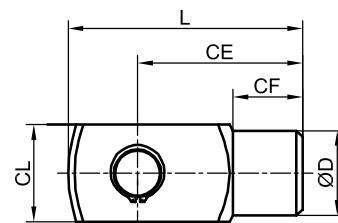
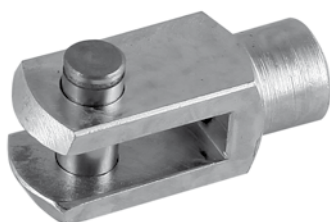

Dimension [mm]										Order number	
CE	CF	CL	CM	ØCK	KK	ØD	L	LE	CT	Complete with pin	Without pin
51	23	34	18	12	M16×1.5	30	64	19	42	10.004G.08.	10.004G.07.
63	28	43	22	16	M20×1.5	40	80	23	52	10.004J.08.	10.004J.07.
85	40	58	30	20	M27×2	54	105	30	68	10.004L.08.	10.004L.07.
115	54.5	77.5	40	25	M36×2	72	140	40	88	10.004N.08.	10.004N.07.

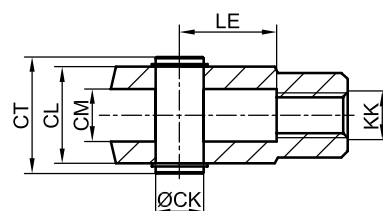

### BRACKET - FOR SERIES SMI, STD

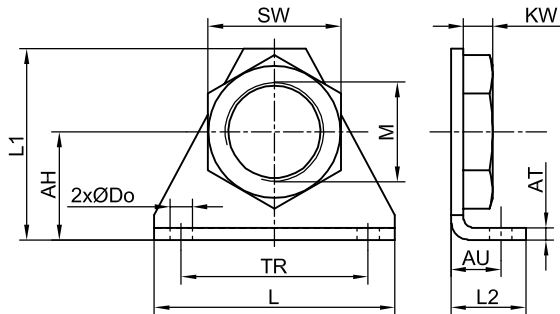

Dimension [mm]											Order number
AH	AT	AU	ØDo H13	KW	L	L1	L2	M	TR	SW	
20	4	14	5.5	6	44	26	10	16x1.5	32	22	10.007A.03.
25	5	17	6.6	7	54	31	12	22x1.5	40	30	10.007C.03.
26	3	12	6.6	7	58	46	18	24x1.5	45	32	10.011E.03.

**Note:** the set consists of a bracket and nut.

### BRACKET - FOR SERIES STK, SSI, SPT, STE, SKP

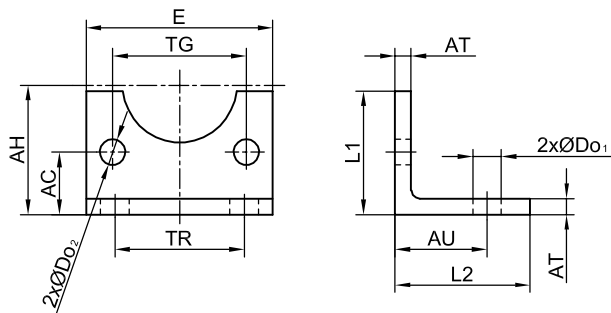

Dimension [mm]											Order number
AC	AH	AT	AU	ØDo1	ØDo2	E	L1	L2	TG	TR	
15.75	32	4	24	7	7	45	30	35	32.5	32	10.014E.03.
17.5	36	4	28	9	7	52	30	36	38	36	10.014F.03.
21.75	45	5	32	9	9	65	36	47	46.5	45	10.014G.03.
21.75	50	5	32	9	9	75	35	45	56.5	50	10.014H.03.
27	63	6	41	12	11	95	47	55	72	63	10.014J.03.
26.5	71	6	41	14	11	115	53	57	89	75	10.014K.03.
35	90	8	45	16	14	140	70	70	100	90	10.014L.03.
45	115	9	60	18	18	180	100	75	100	115	10.014M.03.
47.5	135	12	70	22	18	220	101	100	100	135	10.014N.03.

**Note:** material: bracket - cast iron (D32-D100), carbon steel (D125-D200).

# ACCESSORIES FOR CYLINDERS

## Mounting elements



### BRACKET - FOR THE SCN SERIES

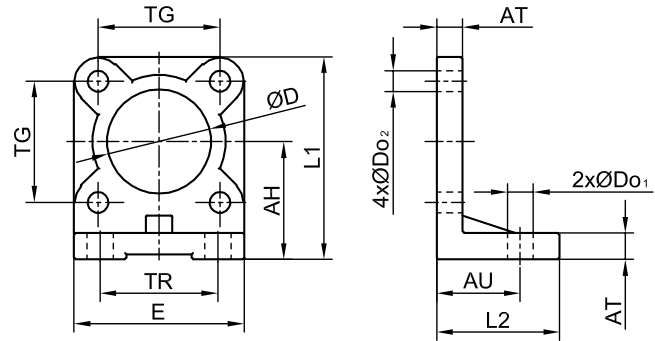

Dimension [mm]											Material	Order number
AH	AT	AU	ØD H11	ØDo2	ØDo1	E	L1	L2	TG	TR		
36	8	27	32	7	9	52	62	35	40	36	cast iron	10.004F.03.
36	8	27	32	7	9	52	62	35	40	36	aluminium alloy	10.004F.03.A
45	10	35	32	9	11	65	77	45	49	45	cast iron	10.004G.03.
45	10	35	32	9	11	65	77	45	49	45	aluminium alloy	10.004G.03.A
50	10	35	45	9	11	75	87	45	59	55	cast iron	10.004H.03.
50	10	35	45	9	11	75	87	45	59	55	aluminium alloy	10.004H.03.A
63	12	43	45	11	14	95	110	55	75	70	cast iron	10.004J.03.
63	12	43	45	11	14	95	110	55	75	70	aluminium alloy	10.004J.03.A
73	12	43	55	11	14	115	130	55	90	90	cast iron	10.004K.03.
73	12	43	55	11	14	115	130	55	90	90	aluminium alloy	10.004K.03.A
91	15	52	55	14	18	140	161	68	110	100	cast iron	10.004L.03.
115	20	62	65	18	22	180	205	80	140	130	cast iron	10.004M.03.
135	20	62	65	18	22	220	245	80	175	170	cast iron	10.004N.03.

### HIGH BRACKET - FOR SERIES STK, STE

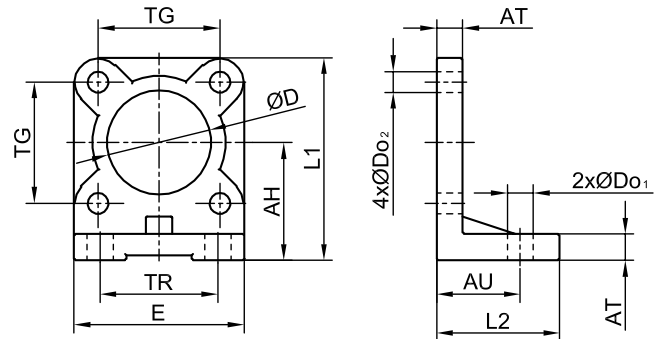

Dimension [mm]											Order number
AH	AT	AU	ØD	ØDo1	ØDo2	E	L1	L2	TG	TR	
32	8	24	30	7	7	45	54.5	35	32.5	32	10.014E.13.A
36	8	28	35	9	7	52	62	35	38	36	10.014F.13.A
45	10	32	40	9	9	65	77.5	45	46.5	45	10.014G.13.A
50	10	32	45	9	9	75	87.5	45	56.5	50	10.014H.13.A
63	12	41	45	12	11	95	110.5	55	72	63	10.014J.13.A
71	12	41	55	14	11	115	128	56	89	75	10.014K.13.A
91	16	45	60	16	14	140	161	68	110	90	10.014L.13.A
115	20	60	65	18	18	180	205	82	140	115	10.014M.13.A
135	20	70	75	22	18	220	245	90	175	135	10.014N.13.A

Note: material - die-cast aluminium

### NUT - FOR SERIES SMI, STD

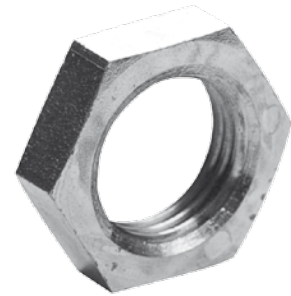
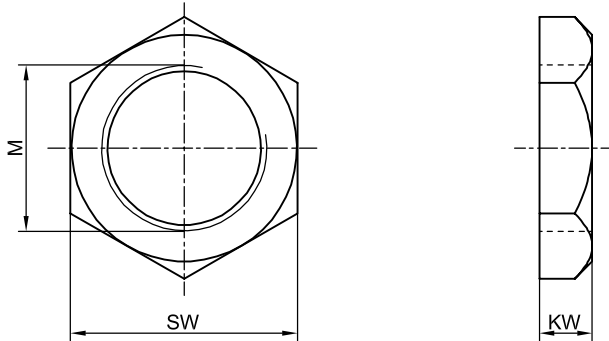

Dimension [mm]			
KW	M	SW	Order number
6	M16x1.5	22	10.007A.05.
7	M22x1.5	30	10.007C.05.
7	M24x1.5	30	10.011E.05

### FLANGE - FOR SERIES SMI, STD

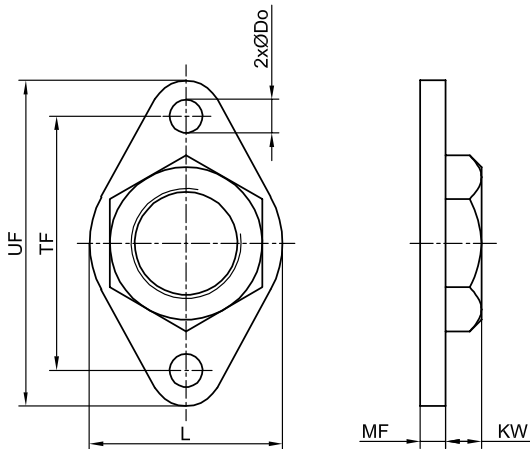

ØDo H13	Dimension [mm]					Order number
	KW	L	MF	TF	UF	
5.5	6	28	4	40	52	10.007A.04.
6.6	7	38	5	50	64	10.007C.04.

Note: the set consists of a flange and nut.

### FLANGE - FOR SCN SERIES

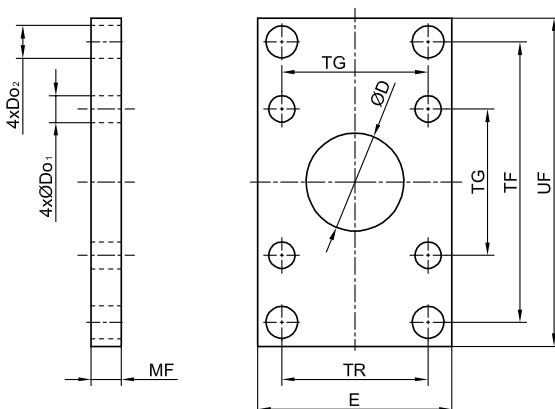

Dimension [mm]									Order number
ØD	ØDo1	ØDo2	E	MF	TF	TG	TR	UF	
32	7	9	52	8	78	40	40	90	10.004F.04.
32	9	11	65	10	94	49	49	110	10.004G.04.
45	9	11	75	10	104	59	59	120	10.004H.04.
45	11	14	95	12	130	75	75	150	10.004J.04.
55	11	14	115	12	150	90	90	170	10.004K.04.
55	14	18	140	16	180	110	110	205	10.004L.04.
65	18	22	180	20	228	140	140	260	10.004M.04.
65	18	22	220	20	268	175	175	300	10.004N.04.

# ACCESSORIES FOR CYLINDERS

## Mounting elements



### FLANGE - FOR STD SERIES

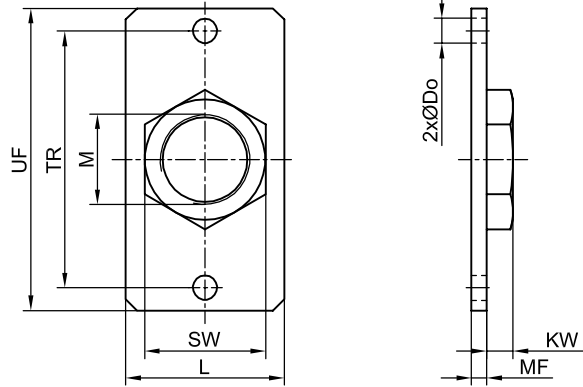

Dimension [mm]								Order number
ØDo	KW	L	M	MF	SW	TR	UF	
6.6	7	42	24x1.5	4	32	68	80	10.011E.04.

Note: the set consists of a flange and nut.

### FLANGE MF1 - MF2 - FOR SERIES STK, SSI, SPT, STE, SKP

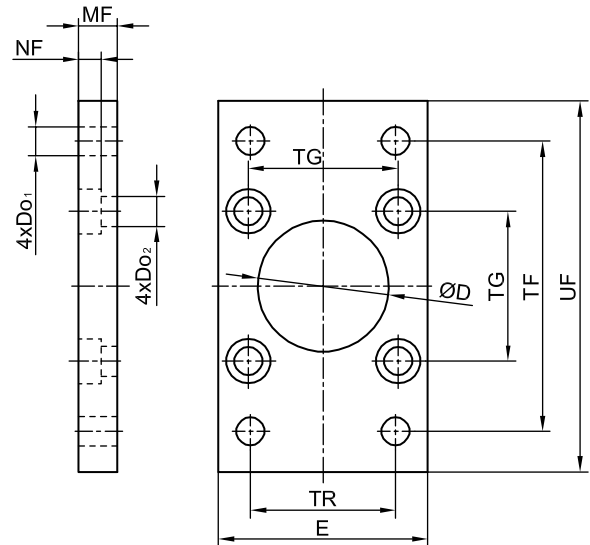

Dimension [mm]										Order number
ØD H11	ØDo1	ØDo2	E	MF	NF	TF	TG	TR	UF	
30	7	6.6	45	10	5	64	32.5	32	80	10.014E.04.
35	9	6.6	52	10	5	72	38	36	90	10.014F.04.
40	9	9	65	12	5.5	90	46.5	45	110	10.014G.04.
45	9	9	75	12	5.5	100	56.5	50	120	10.014H.04.
45	12	11	95	16	8	126	75	63	150	10.014J.04.
55	14	11	115	16	8	150	89	75	170	10.014K.04.
60	16	13.5	140	20	9.5	180	110	90	205	10.014L.04.
65	18	18	180	20	10.5	230	140	115	260	10.014M.03.
75	22	18	220	25	12.5	270	175	135	300	10.014N.04.
90	26	22	285	25	14.5	330	220	165	400	10.014P.04.
110	33	26	350	30	15	400	270	200	470	10.014R.04.

Note: material - carbon steel.

### CENTRAL TRUNNION - FOR SCN SERIES

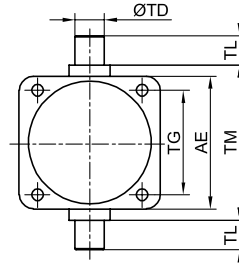
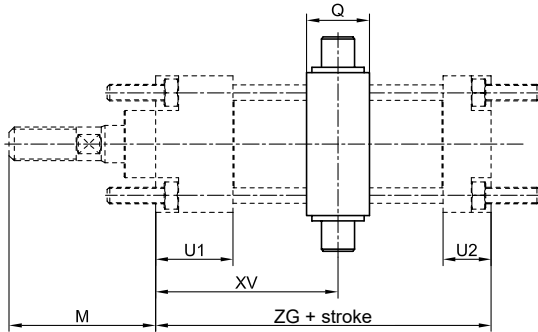

Dimension [mm]												Order number
AE	M	ØTD e9	TG	TL	TM	Q	U1	U2	ZG	XV		
										min.	max.*	
46	45	12	32.5	12	50	15	22	17	80	34	52	10.004E.05.
59	70	16	38	16	63	20	40	23	110	60	70	10.004F.05.
69	70	16	46.5	16	75	20	37	23	110	60	70	10.004G.05.
84	85	20	56.5	20	90	25	43	27	125	64.5	79.5	10.004H.05.
102	85	20	72	20	110	25	37	27	125	64.5	79.5	10.004J.05.
125	110	25	90	25	132	30	51	32	145	74	91	10.004K.05.
155	110	25	110	25	160	32	51	32	145	74	91	10.004L.05.
190	135	32	140	32	200	40	57	43	180	91	110	10.004M.05.
240	135	32	175	32	250	40	57	43	180	91	110	10.004N.05.

**Note:**In the case of ordering a Central Trunnion mounted on a cylinder, please specify the XV size.  
Material - carbon steel.

### CENTRAL TRUNNION - FOR SERIES SSI, SPT

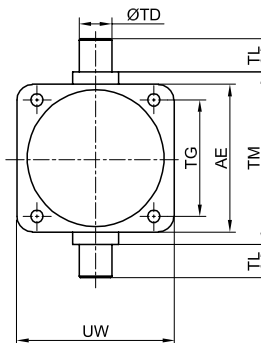
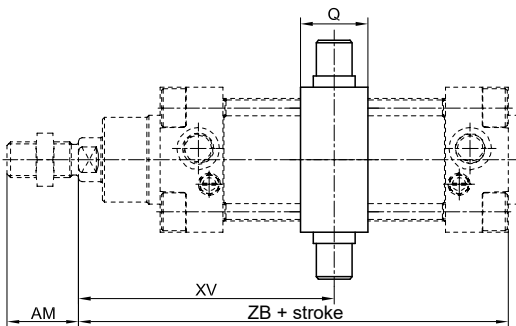

Dimensions											Order number
AE	AM	ØTD e9	TG	TL	TM	Q	UW	XV		ZB	
								min.	max.*		
46	22	12	32.5	12	50	15	46	67	79	120	10.014E.05
52	24	16	38	16	63	20	59	74	91	135	10.014F.05
65	32	16	46.5	16	75	20	69	82	98	143	10.014G.05
75	32	20	56.5	20	90	25	84	87	108	158	10.014H.05
95	40	20	72	20	110	25	102	99	121	174	10.014J.05
113	40	25	89	25	132	30	125	109	132	189	10.014K.05
140	54	25	110	25	160	32	155	145	160	225	10.014L.05
180	72	32	140	32	200	40	190	158	171	260	10.014M.05
220	72	32	175	32	250	40	240	170	181	275	10.014N.05
314	84	40	220	40	320	50	296	192	217	305	10.014P.05

**Note:**In the case of ordering a Central Trunnion mounted on a cylinder, please specify the XV size.  
Material - cast iron

\*Dimension XV<sub>max</sub> defined for a 0 mm stroke. Add cylinder stroke to dimension XV.

# ACCESSORIES FOR CYLINDERS

## Mounting elements



### CENTRAL TRUNNION MT - 4 FOR CYLINDERS WITH SHAPED TUBE - FOR STK SERIES

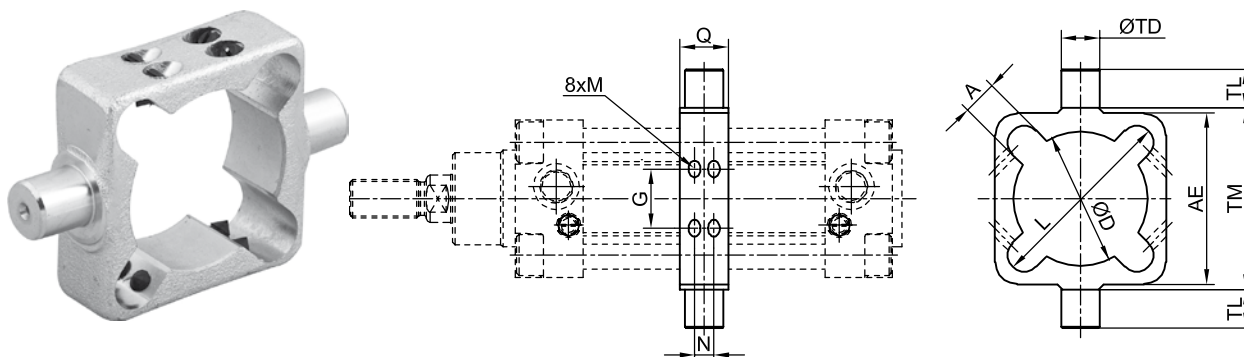

Dimension [mm]											Order number
A <sup>+0.2</sup>	AE	ØD	G	L	M	N	Q	ØTD e9	TL	TM	
11.3	48.5	37	13.5	58	M5	7	18	12	12	50	10.014E.19.
11.3	59	46	19	67.5	M6	8	20	16	16	63	10.014F.19.
14	71	56	24.5	82.5	M6	8	20	16	16	75	10.014G.19.
14	84	69	28	97	M6	12	26	20	20	90	10.014H.19.
16	105	87	36.5	120	M6	12	26	20	20	110	10.014J.19.
17	129	107	42.5	146.5	M8	15	32	25	25	132	10.014K.19.
18	154	133.5	59.5	183	M8	15	33	25	25	160	10.014L.19.

Note: material - carbon steel

### CENTRAL TRUNNION MT - 4 FOR CYLINDERS WITH EURAL PROFILE TUBE - FOR STE SERIES

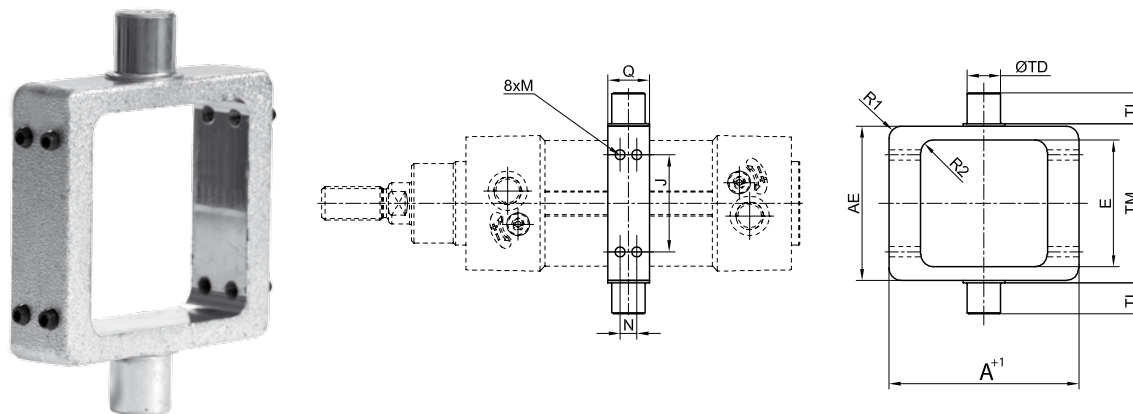

Dimension [mm]											Order number	
A <sup>+1</sup>	AE	E	J	M	N	Q	R1	R2	ØTD e9	TL		TM
70	50	45	32.5	M5	7	18	4	5	12	12	50	10.014E.20.
78	62	51	38	M5	8	20	5	5	16	16	63	10.014F.20.
91	74	60.8	46.5	M6	8	20	6	6	16	16	75	10.014G.20.
94	88	70.5	56.5	M6	12	25	6	6	20	20	90	10.014H.20.
130	109	87.5	72	M8	12	25	7	7	20	20	110	10.014J.20.
145	130	107	89	M8	15	30	8	8	25	25	132	10.014K.20.

Note: material - carbon steel

### BEARING BRACKET FOR CENTRAL TRUNNION - FOR SERIES SCN, STK, SSI, STE

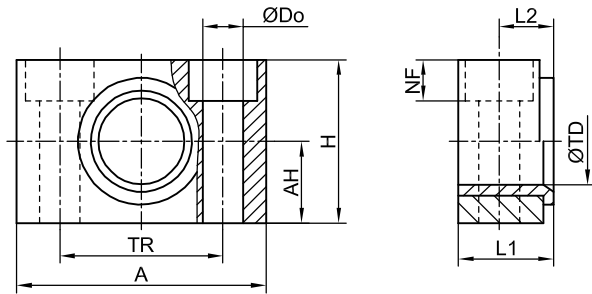

Dimension [mm]										Material	Order number
A	AH	ØDo	H	L1	L2	NF	ØTD F7	TR <sub>±0.2</sub>			
46	15	6.6	30	18	10.5	7	12	32		carbon steel	10.014E.18.
55	18	9	36	21	12	9	16	36		carbon steel	10.014G.18.
65	20	11	40	23	13	11	20	42		carbon steel	10.014J.18.
75	25	14	50	28.5	16	13	25	50		carbon steel	10.014L.18.
92	30	18	60	40	22.5	17	32	60		carbon steel	10.014N.18.
140	35	22	70	56	31	20	40	90		aluminium	10.014P.18.

Note: a bronze bearing tube is used in the bracket.

Central Trunnion bearing bracket sold separately.

### FORK - FOR SCN SERIES

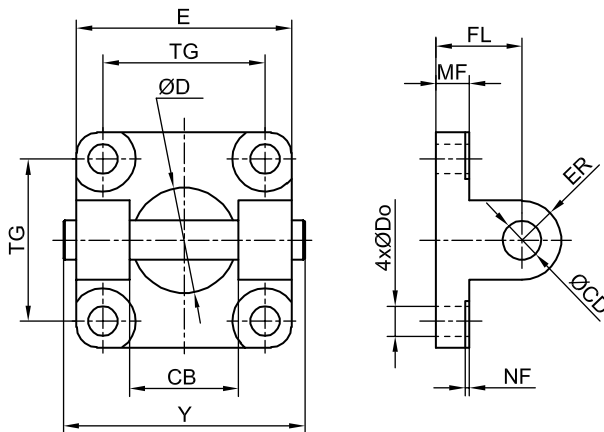

Dimension [mm]											Material	Order number
CB	ØCD	ØDo	ØD H11	E	ER	FL	MF	NF	TG	Y		
33	12	7	32	52	12	24	10	1.4	40	60	cast iron	10.004F.02.
33	12	7	32	52	12	24	10	4.5	40	60	aluminium alloy	10.004F.02.A
33	12	9	32	65	12	26	10	1.2	49	73	cast iron	10.004G.02.
33	12	9	32	65	12	26	10	4.5	49	73	aluminium alloy	10.004G.02.A
47	16	9	45	75	16	30	10	3.6	59	83	cast iron	10.004H.02.
47	16	9	45	75	16	30	10	4.5	59	83	aluminium alloy	10.004H.02.A
47	16	11	45	95	16	32	12	1	75	103	cast iron	10.004J.02.
47	16	11	45	95	16	32	12	4.5	75	103	aluminium alloy	10.004J.02.A
57	20	11	55	115	20	37	12	1.2	90	123	cast iron	10.004K.02.
57	20	11	55	115	20	37	12	4.5	90	123	aluminium alloy	10.004K.02.A
57	20	14	55	140	21	41	16	1.4	110	148	cast iron	10.004L.02.
57	20	14	55	140	21	41	16	10	110	148	aluminium alloy	10.004L.02.A
72	25	18	65	180	25	55	20	1.4	140	188	cast iron	10.004M.02.
72	25	18	65	180	25	55	20	10.5	140	188	aluminium alloy	10.004M.02.A
72	25	18	65	220	25	55	20	16	175	228	cast iron	10.004N.02.
72	25	18	65	220	25	55	20	14	175	228	aluminium alloy	10.004N.02.A



# ACCESSORIES FOR CYLINDERS

## Mounting elements



### FORK MP - 2 - FOR SERIES STK, SSI, SPT, STE, SKP

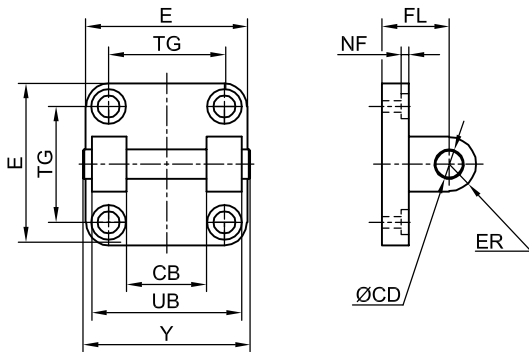

CB	ØCD H9	Dimension [mm]							Material	Order number
		E	ER	FL	NF	TG	UB	Y		
26	10	45	10	22	3.5	32.5	45	52	cast iron	10.014E.02.
26	10	45	10	22	3.5	32.5	45	52	aluminium alloy	10.014E.02.A
28	12	52	12	25	3.5	38	52	59	cast iron	10.014F.02.
28	12	52	12	25	3.5	38	52	59	aluminium alloy	10.014F.02.A
32	12	65	12	27	4.5	46.5	60	67	cast iron	10.014G.02.
32	12	65	12	27	4.5	46.5	60	67	aluminium alloy	10.014G.02.A
40	16	75	16	32	4.5	56.5	70	77.5	cast iron	10.014H.02.
40	16	75	16	32	4.5	56.5	70	77.5	aluminium alloy	10.014H.02.A
50	16	95	16	36	4	72	90	97.5	cast iron	10.014J.02.
50	16	95	16	36	4	72	90	97.5	aluminium alloy	10.014J.02.A
60	20	115	20	41	4	89	110	118	cast iron	10.014K.02.
60	20	115	20	41	4	89	110	118	aluminium alloy	10.014K.02.A
70	25	140	25	50	10	110	130	142	cast iron	10.014L.02.
70	25	140	25	50	10	110	130	142	aluminium alloy	10.014L.02.A
90	25	180	25	55	10	140	170	182	cast iron	10.014M.02.
90	25	180	25	55	10	140	170	182	aluminium alloy	10.014M.02.A
90	25	220	25	60	14	175	170	182	cast iron	10.014N.02.
90	25	220	25	60	14	175	170	182	aluminium alloy	10.014N.02.A
110	40	270	40	70	13.5	220	200	215	cast iron	10.014P.02.
110	40	270	40	70	13.5	220	200	215	aluminium alloy	10.014P.02.A
120	45	350	45	80	15	270	220	235	aluminium alloy	10.014R.02.A

Note: carbon steel forks are available for D125 –D200 cylinders.

### PIN FORK WITH ANTI-ROTATION PROTECTION - FOR SERIES STK, SSI, STE

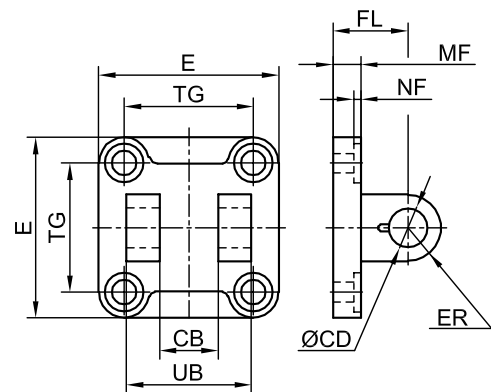

CB H14	ØCD H9	Dimension [mm]							Order number
		E	FL	MF	NF	ER	TG	UB	
14	10	45	22	10	4.5	10	32.5	34	10.014E.23.
16	12	52	25	10	4.5	12	38	40	10.014F.23.
21	16	65	27	10	3.5	12	46.5	45	10.014G.23.
21	16	75	32	12	4.5	15	56.5	51	10.014H.23.
25	20	95	36	14	4	16	72	65	10.014J.23.
25	20	115	41	16	6	20	89	75	10.014K.23.
37	30	140	50	20	10	25	110	97	10.014L.23.

Note: material - carbon steel

### PIN WITH ANTI-ROTATION PROTECTION FOR FORK AND BALL JOINT EYES

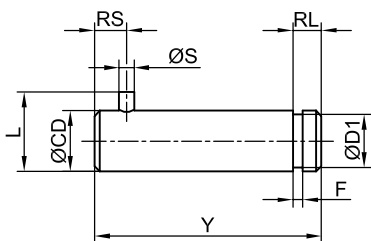

Dimension [mm]								Order number
ØS h12	CR	ØCD f7	ØD1	F H13	RL	Y	L	
3	4.5	10	9.6	1.1	4	41	14	10.014E.26.
4	6	12	11.5	1.1	4	48	16	10.014F.26.
4	6	16	15.2	1.1	5	54	20	10.014G.26.
4	6	16	15.2	1.1	5	60	20	10.014H.26.
4	6	20	19	1.3	6	75	24	10.014J.26.
6	9	20	28.6	1.6	7	110	36	10.014K.26.
6	9	30	28.6	1.6	7	110	36	10.014L.26.

### EYE WITH PIN - FOR STD SERIES

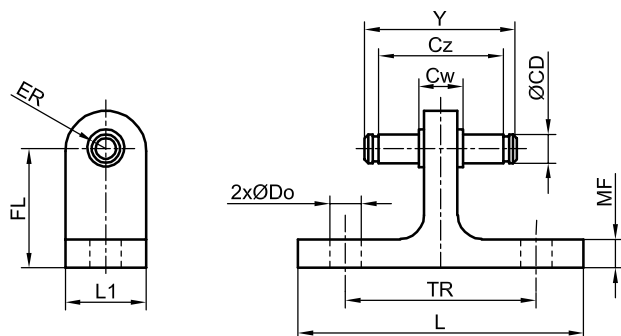

Dimension [mm]											Order number
ØCD	CW	CZ	ØDo	ER	FL	L	L1	MF	TR	Y	
6	8	27	6.6	10	25	60	17	5	40	32.5	10.011E.01.

### EYE WITH PIN - FOR SMI SERIES

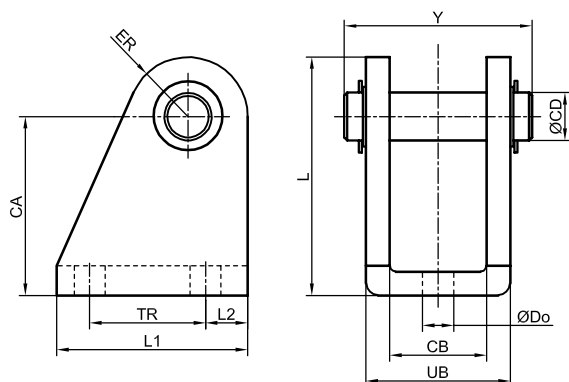

Dimension [mm]											Order number
ØDo H13	CA	CB	Ø CD H11	ER	L	L1	L2	TR	UB	Y	
5.5	20	12.2	6	7	27	25	4.5	16	18.2	24.5	10.007A.01.
	34				10.007A.01.01						
6.6	25	16.2	8	10	35	32	6	20	24.2	30.5	10.007C.01.
	30				40						10.007C.01.01

Note: material - carbon steel

# ACCESSORIES FOR CYLINDERS

## Mounting elements



### STRAIGHT EYE MP - 4 - FOR SERIES STK, SSI, SPT, STE, SKP

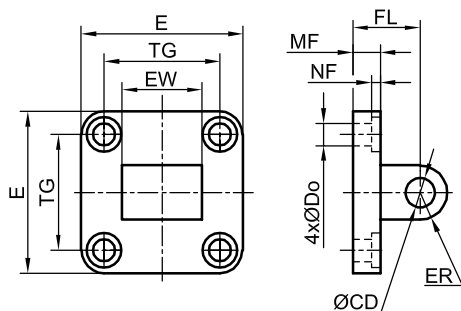

**Note:** carbon steel material version is available for D125-D200 cylinders

ØCD H9	ØDo	Dimension [mm]								Material	Order number
		E	ER	EW	FL	MF	NF	TG			
10	6.6	46.5	9	26	22	9.5	3	32.5	cast iron	10.014E.01.1	
10	6.6	45	10	26	22	9.5	3	32.5	aluminium alloy	10.014E.01.1A	
12	6.6	52	11	28	25	9.5	4.5	38	cast iron	10.014F.01.1	
12	6.6	52	12	28	25	9.5	4.5	38	aluminium alloy	10.014F.01.1A	
12	9	65	11	32	27	11	4.5	46.5	cast iron	10.014G.01.1	
12	9	65	12	32	27	11	4.5	46.5	aluminium alloy	10.014G.01.1A	
16	9	75	14	40	32	11	4.5	56.5	cast iron	10.014H.01.1	
16	9	75	16	40	32	11	4.5	56.5	aluminium alloy	10.014H.01.1A	
16	11	95	15	50	36	14	4.5	72	cast iron	10.014J.01.1	
16	11	95	16	50	36	14	4.5	72	aluminium alloy	10.014J.01.1A	
20	11	113	18	60	41	14	4.5	89	cast iron	10.014K.01.1	
20	11	115	20	60	41	14	4.5	89	aluminium alloy	10.014K.01.1A	
25	14	140	25	70	50	20	10	110	cast iron	10.014L.01.1	
25	14	140	25	70	50	20	10	110	aluminium alloy	10.014L.01.1A	
30	18	180	25	90	55	20	11	140	cast iron	10.014M.01.1	
30	18	180	25	90	55	20	11	140	aluminium alloy	10.014M.01.1A	
30	18	220	40	90	60	25	11	175	cast iron	10.014N.01.1	
30	18	220	40	90	60	25	11	175	aluminium alloy	10.014N.01.1A	
40	22	270	40	110	70	25.5	14	220	cast iron	10.014P.01.1	
40	22	270	40	109	70	25.5	14	220	aluminium alloy	10.014P.01.1A	

### STRAIGHT EYE COMPLETE - FOR SERIES STK, SSI, SPT, STE, SKP

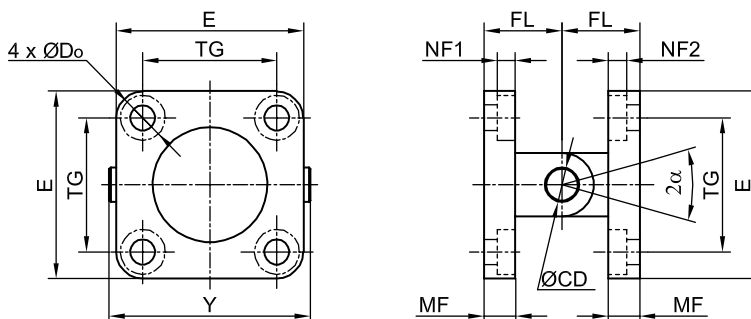

ØCD H9	ØDo	Dimension [mm]								Material	Order number
		E	FL	MF	NF 1	NF 2	TG	Y	α°		
10	11	46.5	22	8	3	4.5	32.5	52	57	cast iron	10.014E.01.
10	11	46.5	22	8	3	4.5	32.5	52	57	aluminium alloy	10.014E.01.A
12	11	52	25	8	4.5	4.5	38	59	60	cast iron	10.014F.01.
12	11	52	25	8	4.5	4.5	38	59	60	aluminium alloy	10.014F.01.A
12	15	65	27	10	4.5	4.5	46.5	67	52	cast iron	10.014G.01.
12	15	65	27	10	4.5	4.5	46.5	67	52	aluminium alloy	10.014G.01.A
16	15	75	32	10	4.5	4.5	56.5	77.5	58	cast iron	10.014H.01.
16	15	75	32	10	4.5	4.5	56.5	77.5	58	aluminium alloy	10.014H.01.A
16	18	95	36	12	4.5	4.5	72	97.5	46	cast iron	10.014J.01.
16	18	95	36	12	4.5	4.5	72	97.5	46	aluminium alloy	10.014J.01.A
20	18	113	41	12	4.5	4.5	89	118	35	cast iron	10.014K.01.
20	18	113	41	12	4.5	4.5	89	118	35	aluminium alloy	10.014K.01.A
25	20	140	50	20	10	10	110	142	30	cast iron	10.014L.01.
25	20	140	50	20	10	10	110	142	30	aluminium alloy	10.014L.01.A
30	26	180	55	20	11	10.5	140	182	30	cast iron	10.014M.01.
30	26	180	55	20	11	10.5	140	182	30	aluminium alloy	10.014M.01.A
30	26	220	60	25	11	14	175	182	28	cast iron	10.014N.01.
30	26	220	60	25	11	14	175	182	28	aluminium alloy	10.014N.01.A
40	34	270	70	25	11	13.5	220	215	28	cast iron	10.014P.01.

### STRAIGHT EYE COMPLETE - FOR SCN SERIES

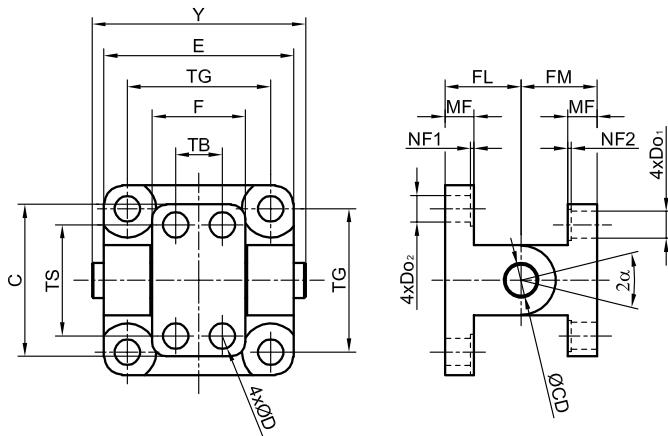

Dimension [mm]																Material	Order number
∅CD	C	∅Do1	∅Do2	E	F	FL	FM	MF	NF 1	NF 2	TG	TS	TB	Y	α°		
12	52	10	7	52	32	24	26	10	1.4	6	40	38	16	60	50	cast iron	10.004F.01.
12	52	10	7	52	32	24	26	10	4.5	6	40	38	16	60	50	aluminium alloy	10.004F.01.A
12	52	10	9	65	32	26	26	10	1.2	8	49	38	16	73	60	cast iron	10.004G.01.
12	52	10	9	65	32	26	26	10	4.5	8	49	38	16	73	60	aluminium alloy	10.004G.01.A
16	76	12	9	75	46	30	34	12	3.6	8	59	54	25	83	60	cast iron	10.004H.01.
16	76	12	9	75	46	30	34	12	4.5	8	59	54	25	83	60	aluminium alloy	10.004H.01.A
16	76	12	11	95	46	32	34	12	1	10	75	54	25	103	60	cast iron	10.004J.01.
16	76	12	11	95	46	32	34	12	4.5	10	75	54	25	103	60	aluminium alloy	10.004J.01.A
20	115	16	11	115	56	37	41	16	1.2	10	90	90	32	123	60	cast iron	10.004K.01.
20	115	16	11	115	56	37	41	16	4.5	10	90	90	32	123	60	aluminium alloy	10.004K.01.A
20	115	16	11	140	56	41	41	16	1.4	12	110	90	32	148	60	cast iron	10.004L.01.
20	115	16	11	140	56	41	41	16	10	12	110	90	32	148	60	aluminium alloy	10.004L.01.A
25	180	20	18	180	71	55	55	20	1.4	16	140	150	43	188	60	cast iron	10.004M.01.
25	180	20	18	180	71	55	55	20	10.5	16	140	150	43	188	60	aluminium alloy	10.004M.01.A
25	180	20	18	220	71	55	55	20	1.6	16	175	150	43	228	60	cast iron	10.004N.01.
25	180	20	18	220	71	55	55	20	14	16	175	150	43	228	60	aluminium alloy	10.004N.01.A

### STRAIGHT EYE WITH BALL JOINT - FOR SERIES STK, SSI, SPT, STE

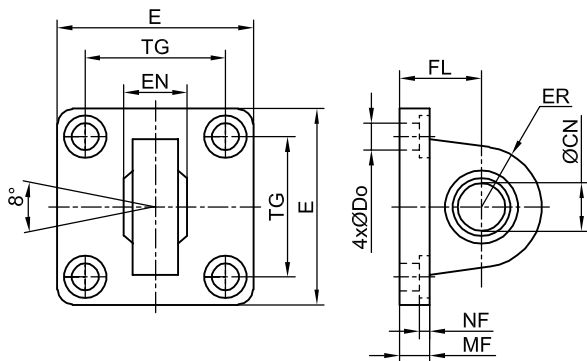

Dimension [mm]										Order number
∅CN H7	∅Do	E	EN	ER	FL	MF	NF	TG		
10	6.6	45	14	15	22	10	4.5	32.5		10.014E.16.
12	6.6	55	16	18	25	10	4.5	38		10.014F.16.
16	9	65	21	20	27	10	3.5	46.5		10.014G.16.
16	9	75	21	23	32	12	5.5	56.5		10.014H.16.
20	11	95	25	27	36	14	4	72		10.014J.16.
20	11	115	25	30	41	16	6	89		10.014K.16.
30	13.5	140	37	40	50	20	10	110		10.014L.16.

Note: material: eye - cast iron, bearing - alloy steel.  
 Note: for use with forks 10.014X.23 (page 1.17.01.20)

# ACCESSORIES FOR CYLINDERS

## Mounting elements



### ANGLE EYE COMPLETE - FOR SERIES STK, SSI, SPT, STE, SKP

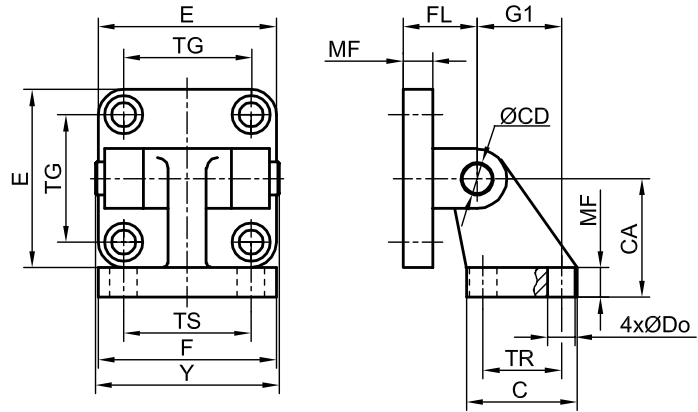

Dimension [mm]													Material version	Order number
C	CA	ØCD H9	ØDo	E	F	FL	G1	MF	TG	TR	TS	Y		
31	32	10	6.6	46.5	51	22	21	8	32.5	18	38	52	cast iron	10.014E.15.
31	32	10	6.6	46.5	51	22	21	8	32.5	18	38	52	aluminium alloy	10.014E.15.A
35	36	12	6.6	52	54	25	24	10	38	22	41	59	cast iron	10.014F.15.
35	36	12	6.6	52	54	25	24	10	38	22	41	59	aluminium alloy	10.014F.15.A
45	45	12	9	65	65	27	33	12	46.5	30	50	67	cast iron	10.014G.15.
45	45	12	9	65	65	27	33	12	46.5	30	50	67	aluminium alloy	10.014G.15.A
50	50	16	9	75	67	32	37	14	56.5	35	52	77.5	cast iron	10.014H.15.
50	50	16	9	75	67	32	37	14	56.5	35	52	77.5	aluminium alloy	10.014H.15.A
60	63	16	11	95	86	36	47	14	72	40	66	97.5	cast iron	10.014J.15.
60	63	16	11	95	86	36	47	14	72	40	66	97.5	aluminium alloy	10.014J.15.A
70	71	20	11	113	96	41	55	17	89	50	76	118	cast iron	10.014K.15.
70	71	20	11	113	96	41	55	17	89	50	76	118	aluminium alloy	10.014K.15.A
90	90	25	14	140	124	50	70	20	110	60	94	142	cast iron	10.014L.15.
126	115	30	14	180	156	55	97	25	140	88	118	182	cast iron	10.014M.15.
130	135	30	18	220	162	60	105	30	175	90	122	182	cast iron	10.014N.15.

### ANGLE EYE WITH BALL JOINT

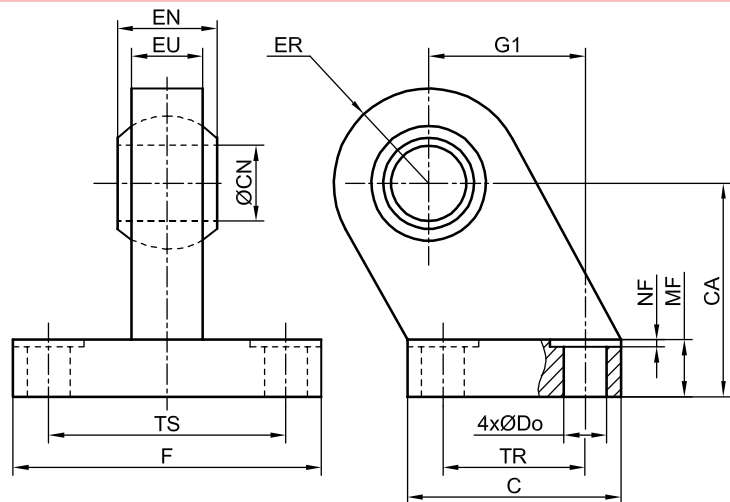

Dimension [mm]													Order number
C	CA	ØCN H7	ØDo	EN	ER	EU	F	G1	MF	NF	TR	TS	
31	32	10	6.6	14	15	10.5	51	21	10	1.5	18	38	10.014E.17.
35	36	12	6.6	16	18	12	54	24	10	1.5	22	41	10.014F.17.
45	45	16	9	21	20	15	65	33	12	1.5	30	50	10.014G.17.
50	50	16	9	21	23	15	67	37	12	1.5	35	52	10.014H.17.
60	63	20	11	25	27	18	86	47	14	2.5	40	66	10.014J.17.
70	71	20	11	25	30	18	96	55	15	2.5	50	76	10.014K.17.
90	90	30	13.5	37	40	25	124	70	20	3	60	94	10.014L.17.

Note: Material: eye - cast iron, bearing - alloy steel.

Note: for use with forks 10.014X.23 (page 1.17.01.20)

#### TECHNICAL SPECIFICATIONS

<b>Operating position:</b>	any position
<b>Construction materials:</b>	
<b>Body, front plate</b>	- aluminium alloy
<b>Rod</b>	- chrome-plated carbon steel
<b>Guide elements</b>	- bronze sinter
<b>Diameters:</b>	D20–D25
<b>Standard stroke range:</b>	5–500 mm*

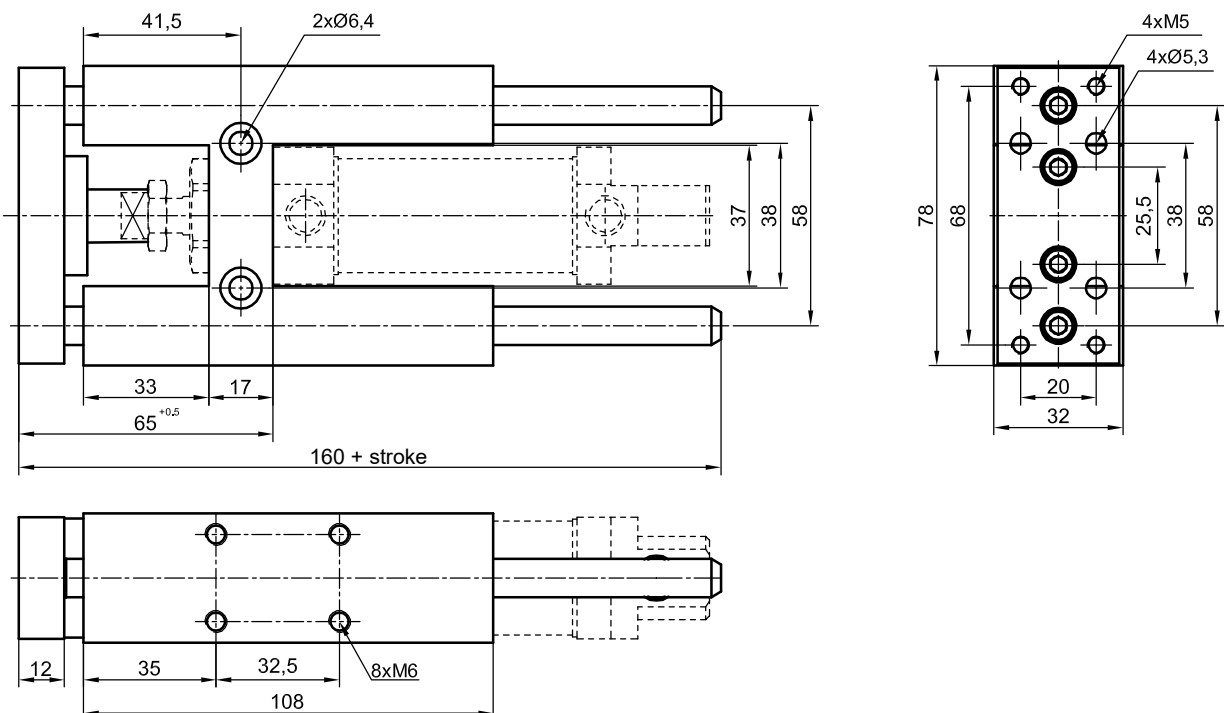
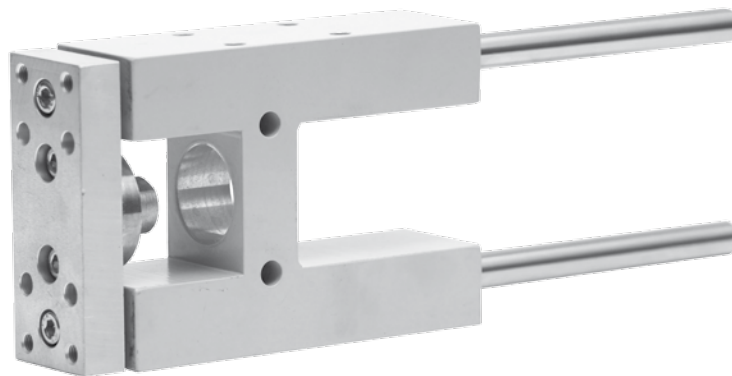

\*Other stroke lengths manufactured after prior technical consultation.

# ACCESSORIES FOR CYLINDERS

Guides for mini-cylinders SMI series



## USEFUL LOAD DIAGRAM FOR THE GUIDE

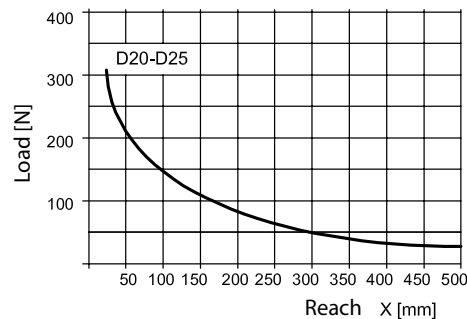
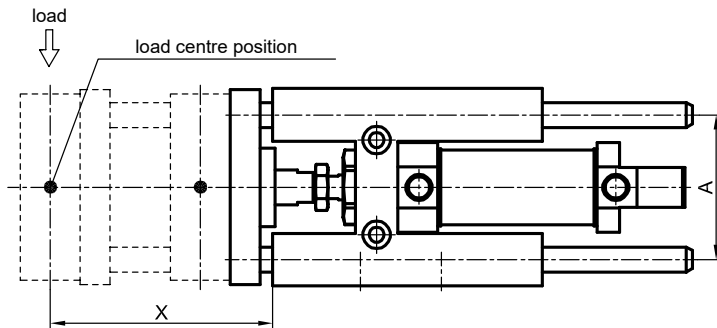

## ORDER NUMBER CONSTRUCTION

**10 . 014 C . 90 . 0200**

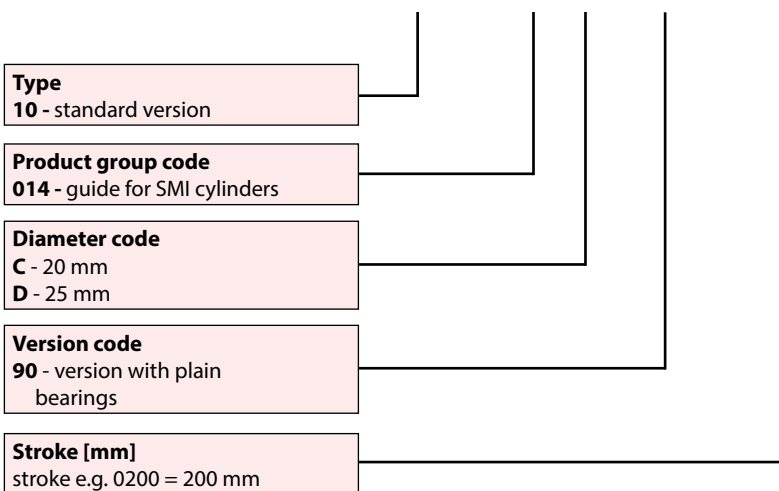

**Note:** the order includes only the guide.

## ORDERING PROCEDURE

In your order, please specify: name, order number of the guide, nominal diameter and stroke of the cylinder used with the guide and the number of pieces, e.g.

**Guide no. 10.014D.90.0200 for SMI cylinder D25 x 200 1 pc.**

### TECHNICAL SPECIFICATIONS

<b>Maximum operating pressure:</b>	10 bar
<b>Medium:</b>	compressed air, filtered, lubricated or non-lubricated
<b>Contents of the set:</b>	- cylinder - guide
<b>Sealing</b>	- polyurethane (working temperature from -20 to +80°C)
<b>Diameters:</b>	- D20-D25
<b>Standard stroke range:</b>	- 5-300 mm*



### H TYPE GUIDE

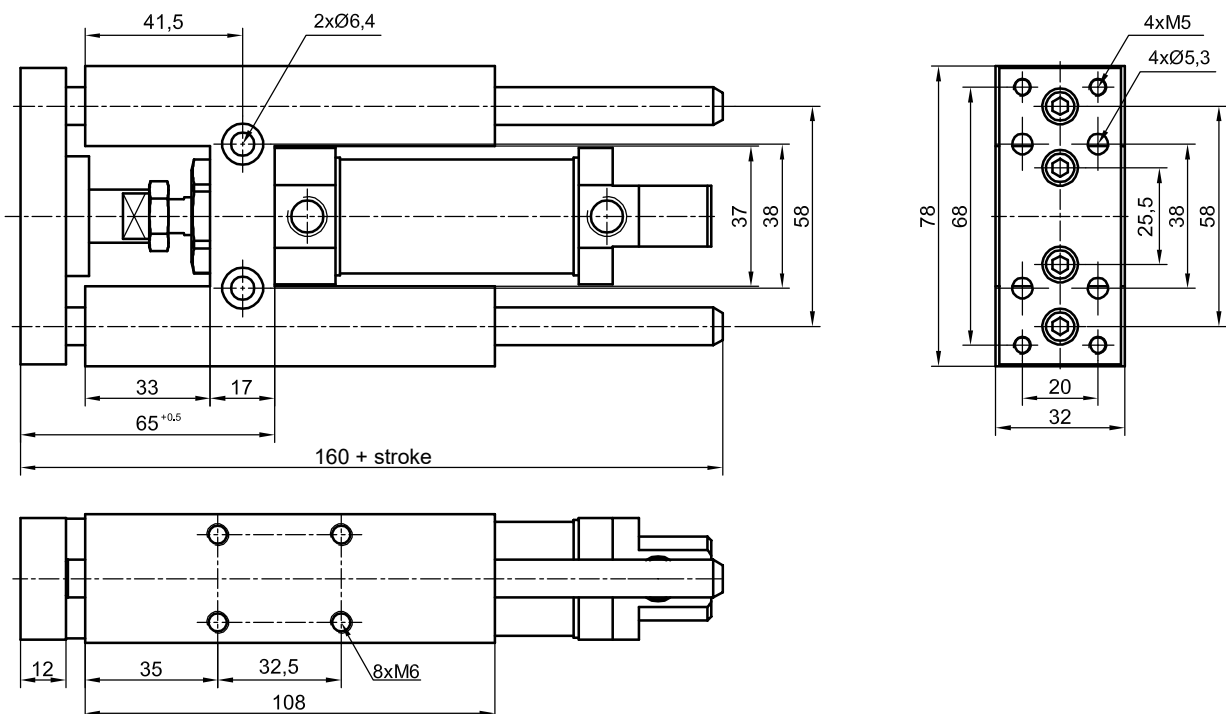

\*Other stroke lengths manufactured after prior technical consultation.



# ACCESSORIES FOR CYLINDERS

## SMI mini-cylinder with guide



### ORDER NUMBER COMPOSITION

**K1 . 018 D . 0100 . K R**

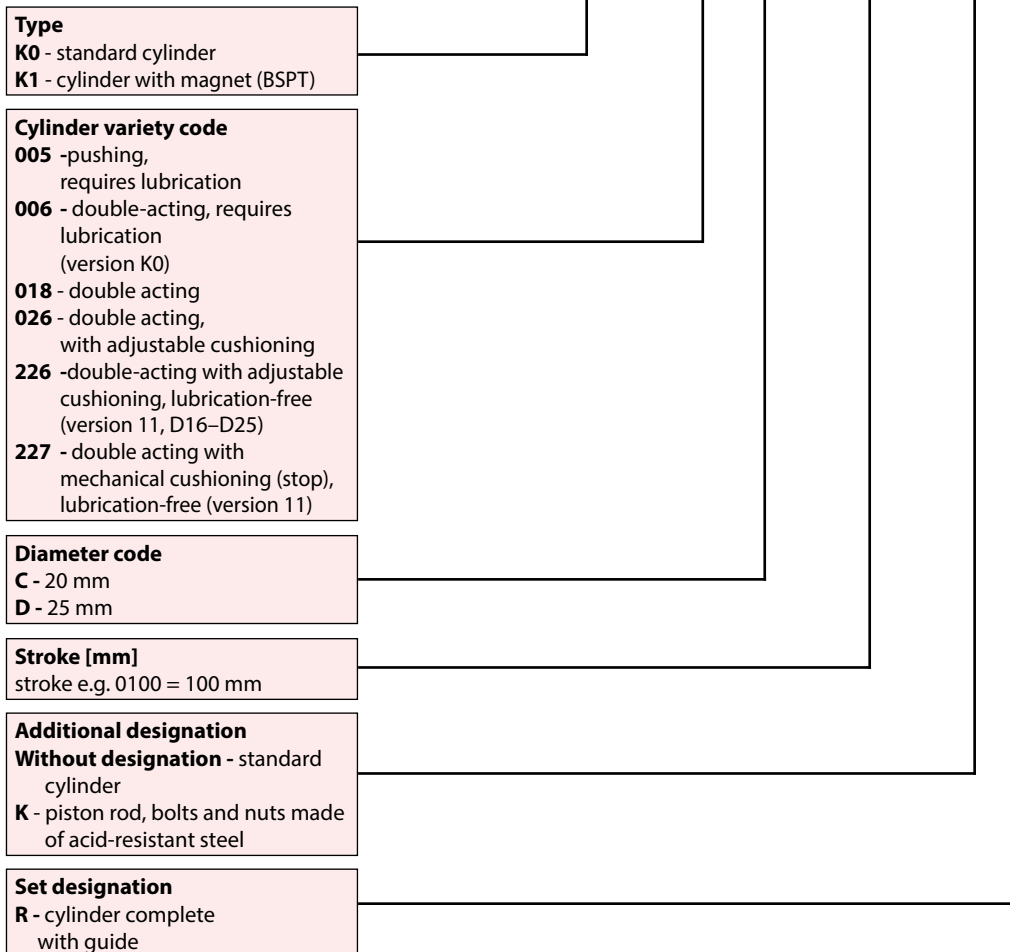

### ORDERING PROCEDURE

In your order, please specify: name, nominal diameter, stroke of SMI cylinder and the the number of pieces, e.g.:

**Mini-cylinder SMI with guide D20x100 K1.018C.0100.KR 1 pc.**

\* Other versions after technical consultation

### TECHNICAL SPECIFICATIONS

<b>Operating temperature range:</b> from -20 to +80°C
<b>Construction materials:</b>
<b>Body, front plate</b> - aluminium alloy
<b>Rod</b> - chrome-plated carbon steel
<b>Guide elements</b> - bronze sinter / ball bearings
<b>Diameters:</b> D32–D100
<b>Standard stroke range:</b> 5–500 mm*

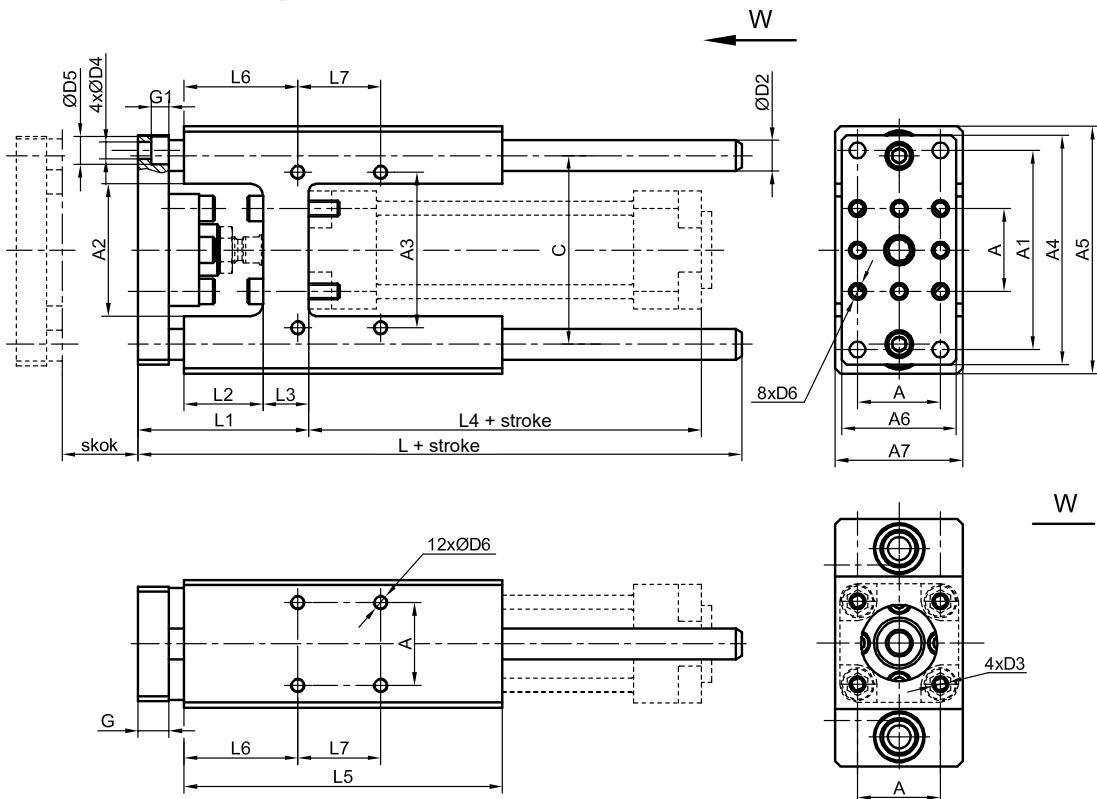
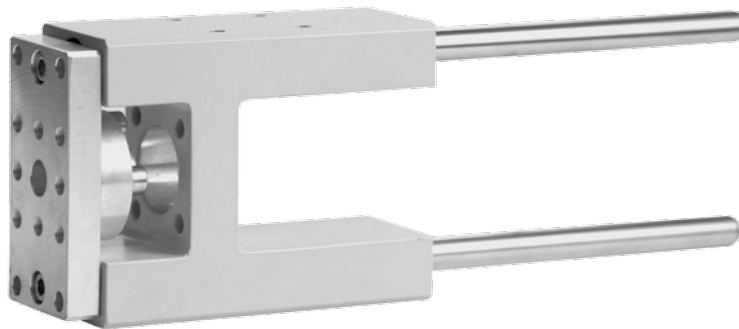

Cylinder diameter [mm]	Dimension [mm]																										
	A	A1	A2	A3	A4	A5	A6	A7	C	ØD2	D3	ØD4	ØD5	D6	G	G1	L	L1	L2	L3	L4	L5	L6	L7			
32	32.5	78	52	61	90	97	45	50	74	12	M6	6.6	11	M6	12	6.5	177	67	31	18	94	125	44.7	32.5			
40	38	84	58	69	110	115	54	58	87	16	M6	6.6	11	M6	12	6.5	192	75	37	22	105	140	48	38			
50	46.5	100	70	85	130	137	63	70	104	20	M8	9	13	M8	15	9	237	89	45	26	106	150	52.5	46.5			
63	56.5	105	86	100	145	152	80	85	119	20	M8	9	13	M8	15	9	237	89	45	26	121	182	55.7	56.5			
80	72	130	106	130	180	189	100	105	148	25	M10	11	16.5	M10	20	11	280	111	55	32	128	215	66	72			
100	89	150	130	150	200	213	120	130	172	25	M10	11	16.5	M10	20	11	280	116	56	36	138	220	67.5	89			

**Note:** when mounting sensors to the cylinder with a guide, use appropriate brackets. See page 179 for details

\* Other stroke lengths manufactured after prior technical consultation.

# ACCESSORIES FOR CYLINDERS

"H" type guide  
for SSI, SCN, STK, STE series



## USEFUL LOAD DIAGRAM FOR THE GUIDE

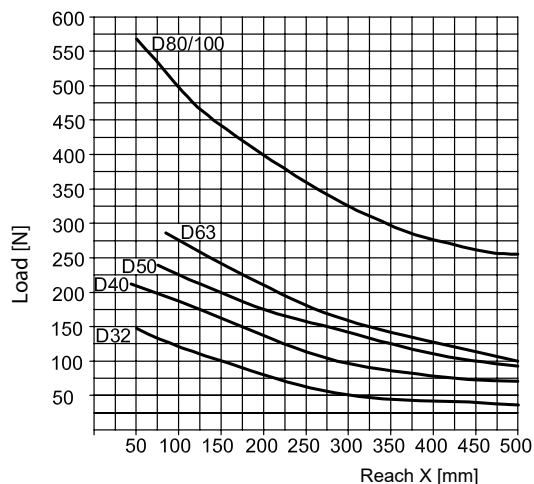
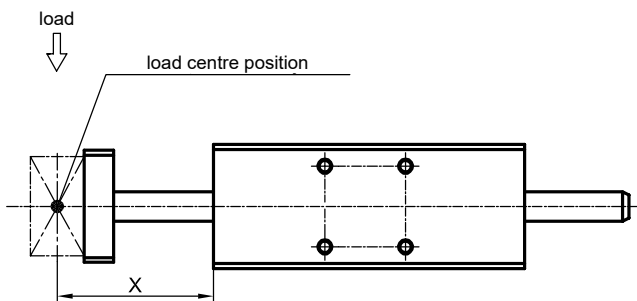

## ORDER NUMBER CONSTRUCTION

**10 . 014 E . 90 . 0500**

<b>Type</b> 10 - standard version	
<b>Product group code</b> 014 - guide for SCN, SSI, STK, STE cylinders	
<b>Diameter code</b> E - 32 mm F - 40 mm G - 50 mm H - 63 mm J - 80 mm K - 100 mm	
<b>Version code</b> 90 - with plain bearings 91 - with ball bearings	
<b>Stroke [mm]</b> stroke e.g. 0500 = 500 mm	

**Note:** the order includes only the guides.

## ORDERING PROCEDURE

In your order, please specify: name, order number of the guide, nominal diameter and stroke of the cylinder used with the guide and the number of pieces, e.g.

**Guide no. 10.014H.90.0500 for SSI cylinder D63 x 500 1 pc.**

### TECHNICAL SPECIFICATIONS

<b>Operating temperature range:</b> from -20 to +80°C
<b>Construction materials:</b>
<b>Body, front plate</b> - aluminium alloy
<b>Rod</b> - chrome-plated carbon steel
<b>Guide elements</b> - bronze sinter
<b>Diameters:</b> D32-D100
<b>Standard stroke range:</b> 5-500 mm*

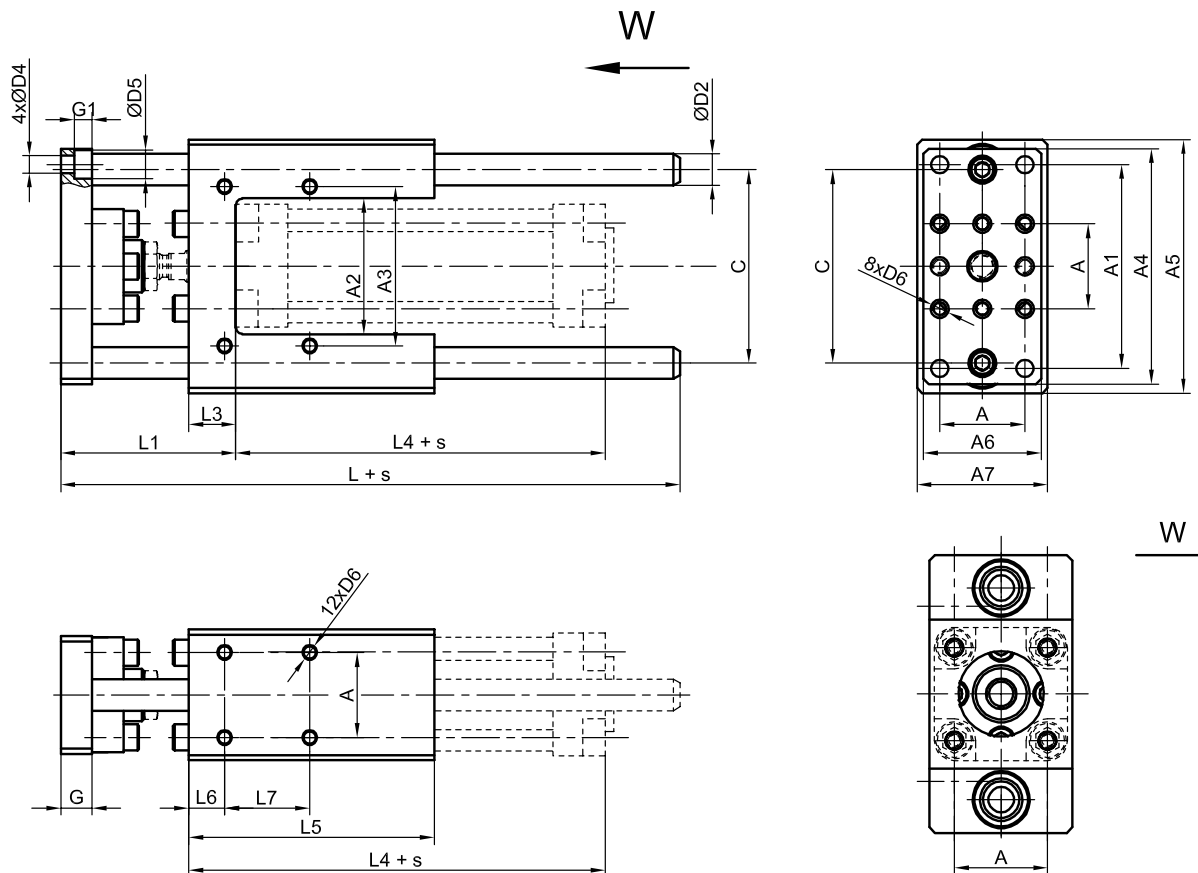
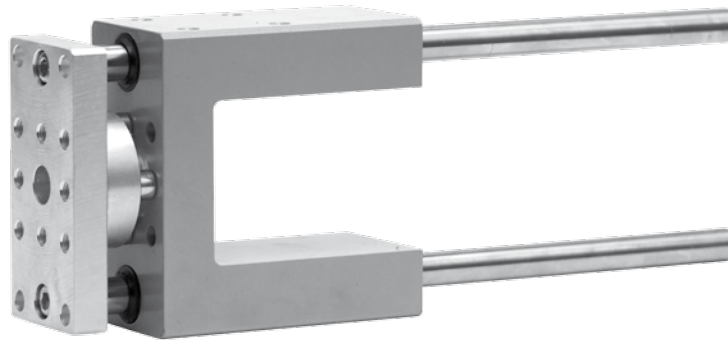

Cylinder diameter [mm]	Dimension [mm]																					
	A	A1	A2	A3	A4	A5	A6	A7	C	Ø D2	Ø D4	Ø D5	D6	G	G1	L	L1	L3	L4	L5	L6	L7
32	32.5	78	52	61	90	97	45	50	74	12	6.6	11	M6	12	6.8	177	67	18	94	94	13.5	32.5
40	38	84	58	69	110	115	54	58	87	16	6.6	11	M6	12	6.8	192	75	22	105	103	10.5	38
50	46.5	100	70	85	130	137	63	70	104	20	9	15	M8	15	9	237	89	26	106	105	13	46.5
63	56.5	105	86	100	145	152	80	85	119	20	9	15	M8	15	9	237	89	26	121	137	13	56.5
80	72	130	106	130	180	189	100	105	148	25	11	18	M10	20	11	280	111	32	128	160	17	72
100	89	150	130	150	200	213	120	130	172	25	11	18	M10	20	11	280	116	36	138	164	19.5	89

**Note:** when mounting sensors to the cylinder with a guide, use appropriate brackets. Details on page 179

\*Other stroke lengths manufactured after prior technical consultation.

# ACCESSORIES FOR CYLINDERS

"U" type guide  
for SSI, SCN, STK, STE series



## USEFUL LOAD DIAGRAM FOR THE GUIDE

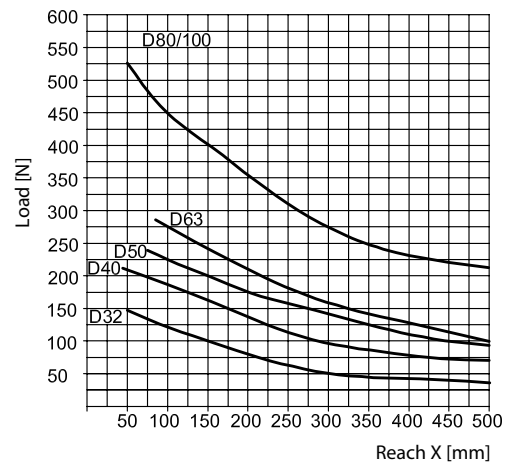
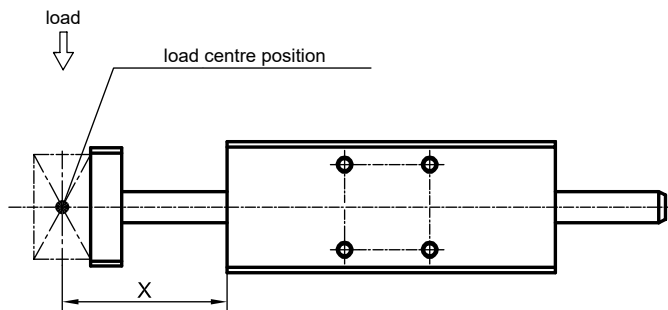

## ORDER NUMBER CONSTRUCTION

**10.014 E.92.0500**

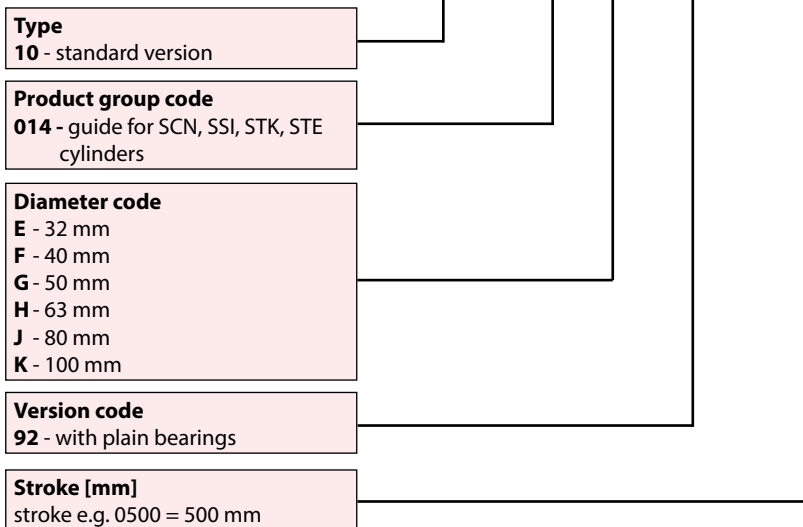

**Note:** the order includes only the guides.

## ORDERING PROCEDURE

In your order, please specify: name, order number of the guide, nominal diameter and stroke of the cylinder used with the guide and the number of pieces, e.g.

**Guide no. 10.014E.92.0500 for SSI cylinder D63 x 500 1 pc.**

## TECHNICAL SPECIFICATIONS

<b>Maximum operating pressure:</b>	10 bar
<b>Medium:</b>	compressed air, filtered, lubricated or non-lubricated
<b>Contents of the set:</b>	- cylinder - guide
<b>Sealing:</b>	- polyurethane (working temperature from -20 to +80°C)
<b>Diameters:</b>	D32-D100
<b>Standard stroke range:</b>	5-500 mm*



## H TYPE GUIDE

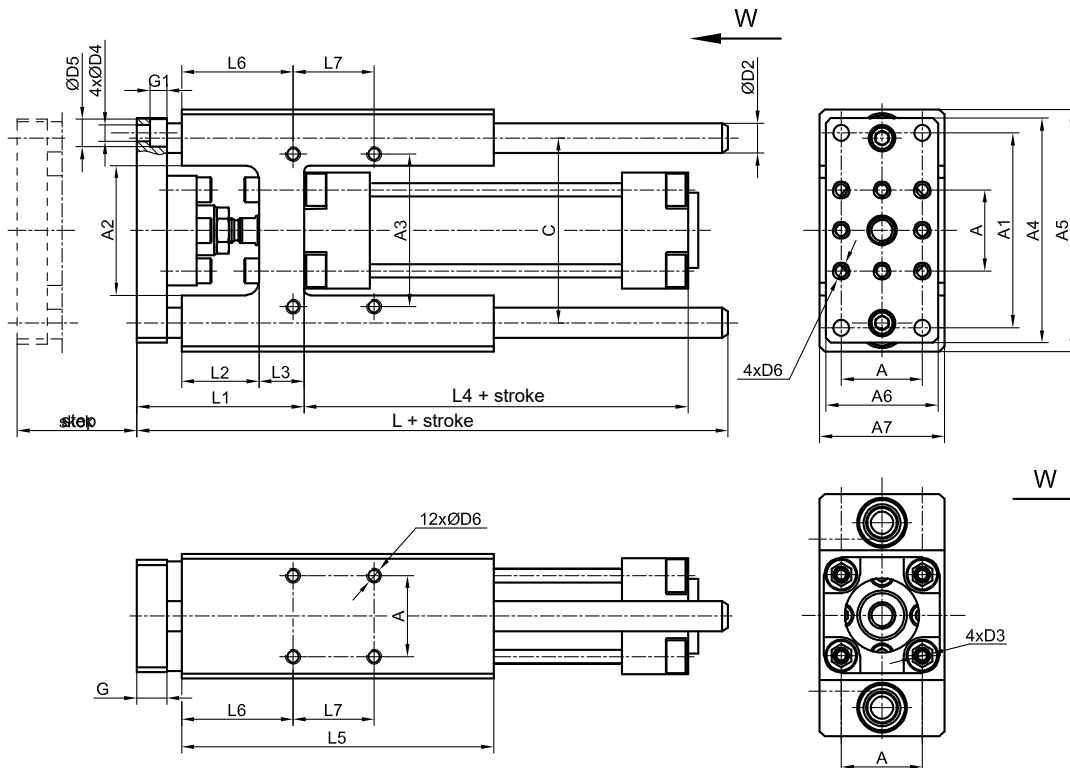

Cylinder diameter [mm]	Dimension [mm]																							
	A	A1	A2	A3	A4	A5	A6	A7	C	ØD2	D3	ØD4	ØD5	D6	G	G1	L	L1	L2	L3	L4	L5	L6	L7
32	32.5	78	52	61	90	97	45	50	74	12	M6	6.6	11	M6	12	6.5	177	67	31	18	94	125	44.7	32.5
40	38	84	58	69	110	115	54	58	87	16	M6	6.6	11	M6	12	6.5	192	75	37	22	105	140	48	38
50	46.5	100	70	85	130	137	63	70	104	20	M8	9	13	M8	15	9	237	89	45	26	106	150	52.5	46.5
63	56.5	105	86	100	145	152	80	85	119	20	M8	9	13	M8	15	9	237	89	45	26	121	182	55.7	56.5
80	72	130	106	130	180	189	100	105	148	25	M10	11	16.5	M10	20	11	280	111	55	32	128	215	66	72
100	89	150	130	150	200	213	120	130	172	25	M10	11	16.5	M10	20	11	280	116	56	36	138	220	67.5	89

\*Other stroke lengths manufactured after prior technical consultation.

# ACCESSORIES FOR CYLINDERS

SSI cylinders complete with guides



## U TYPE GUIDE

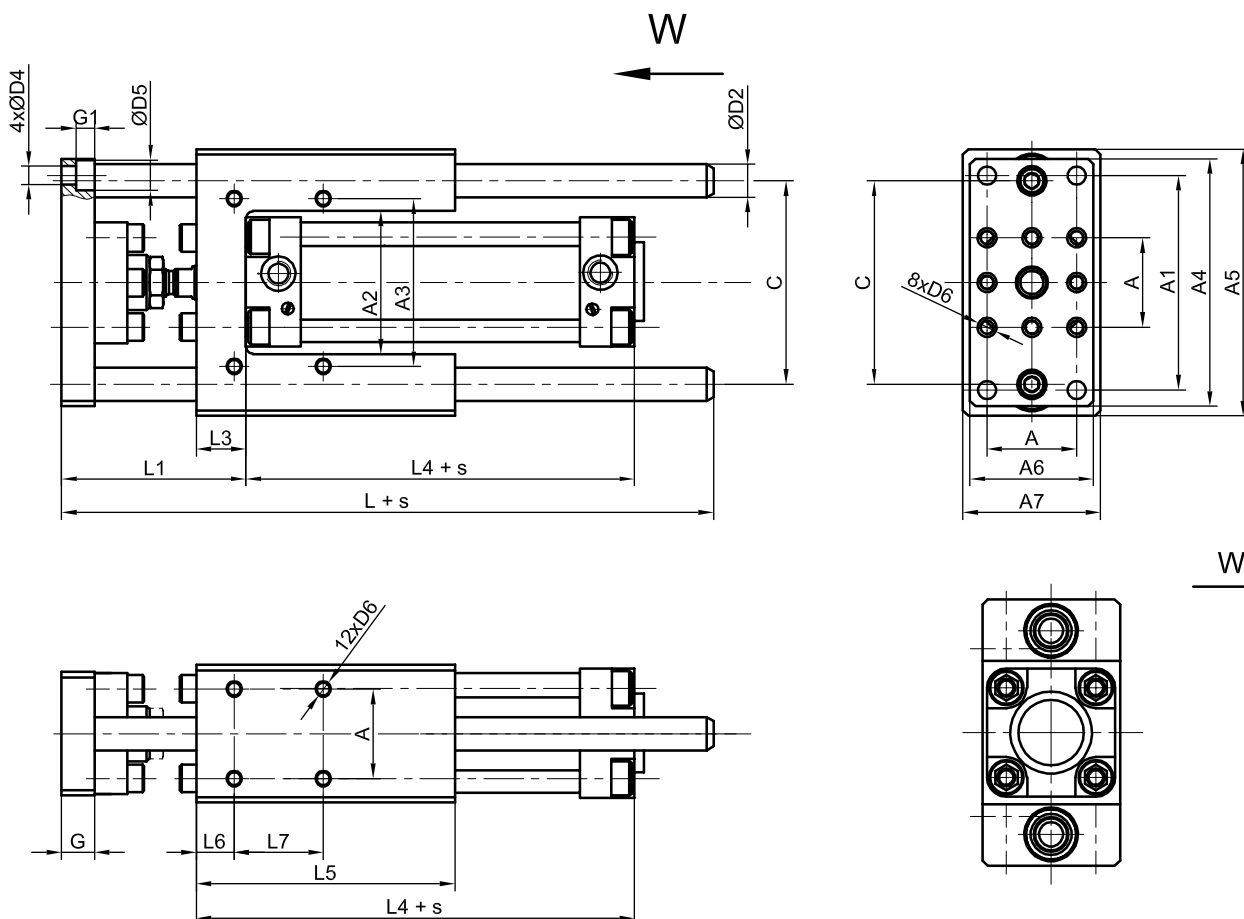

Cylinder diameter [mm]	Dimension [mm]																					
	A	A1	A2	A3	A4	A5	A6	A7	C	Ø D2	Ø D4	Ø D5	D6	G	G1	L	L1	L3	L4	L5	L6	L7
32	32.5	78	52	61	90	97	45	50	74	12	6.6	11	M6	12	6.8	177	67	18	94	94	13.5	32.5
40	38	84	58	69	110	115	54	58	87	16	6.6	11	M6	12	6.8	192	75	22	105	103	10.5	38
50	46.5	100	70	85	130	137	63	70	104	20	9	15	M8	15	9	237	89	26	106	105	13	46.5
63	56.5	105	86	100	145	152	80	85	119	20	9	15	M8	15	9	237	89	26	121	137	13	56.5
80	72	130	106	130	180	189	100	105	148	25	11	18	M10	20	11	280	111	32	128	160	17	72
100	89	150	130	150	200	213	120	130	172	25	11	18	M10	20	11	280	116	36	138	164	19.5	89

**Note:** the technical data of the guide can be found on pages 1.17.03.01 and 1.17.03.03

## ORDER NUMBER COMPOSITION

**K1 . 016 G . 0350 . A K R**

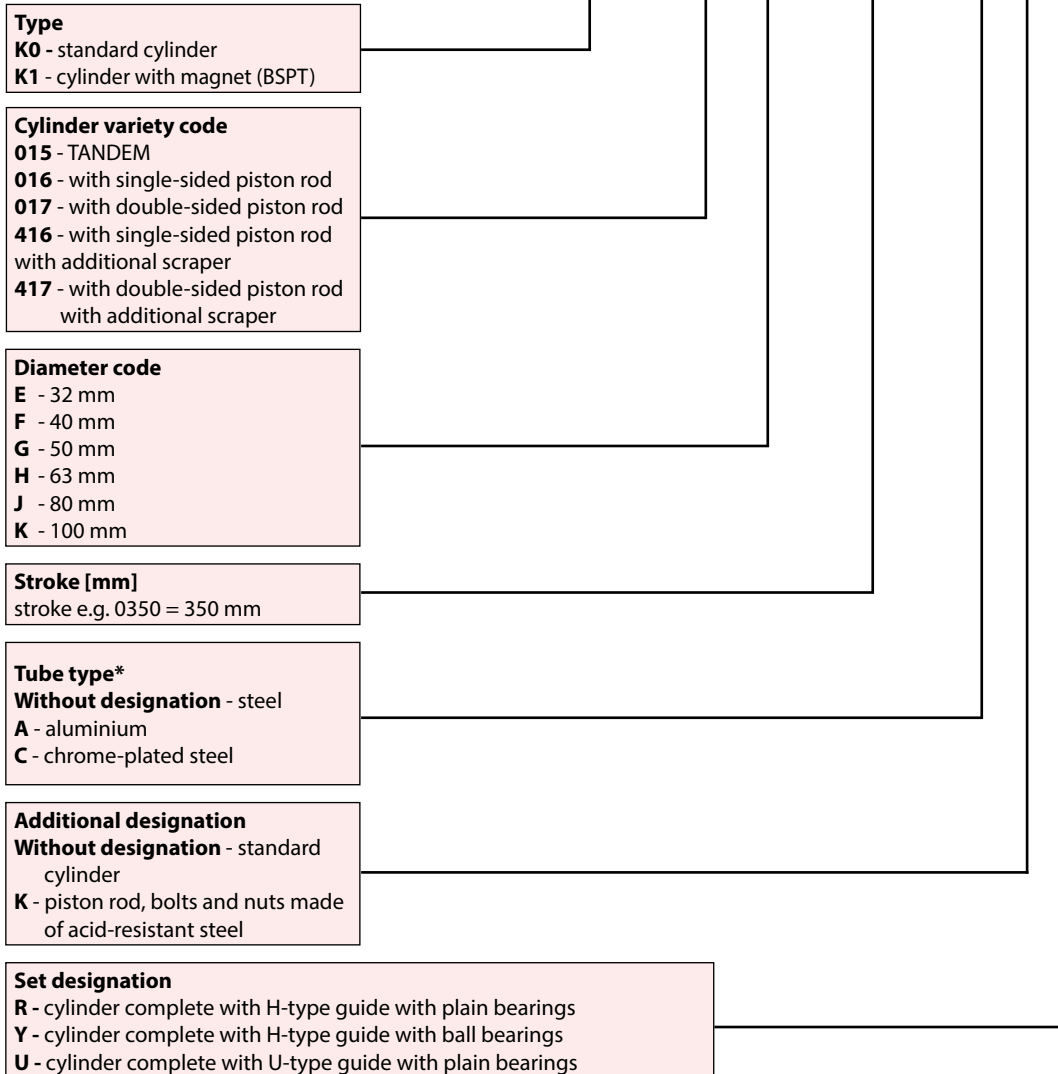

## ORDERING PROCEDURE

In your order, please specify: name, nominal diameter, stroke of SSI cylinder and the the number of pieces, e.g.:

**Cylinder SSI D16x350 K1.016G.0350.AKR with guide 1 pc.**





### TECHNICAL SPECIFICATIONS

<b>Maximum operating pressure:</b>	10 bar
<b>Medium:</b>	compressed air, filtered, lubricated or non-lubricated
<b>Contents of the set:</b>	- cylinder - guide
<b>Sealing:</b>	- polyurethane (working temperature from -20 to +80°C)
<b>Diameters:</b>	D32-D100
<b>Standard stroke range:</b>	5-500 mm*

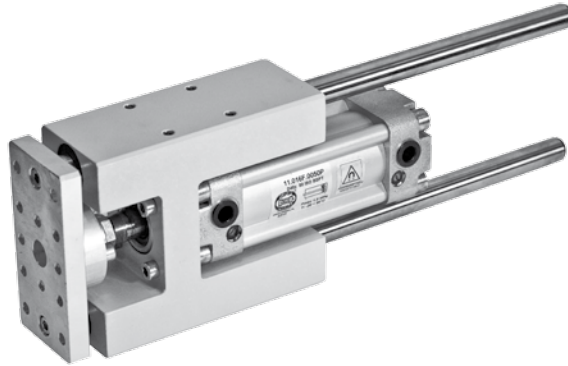

### H TYPE GUIDE

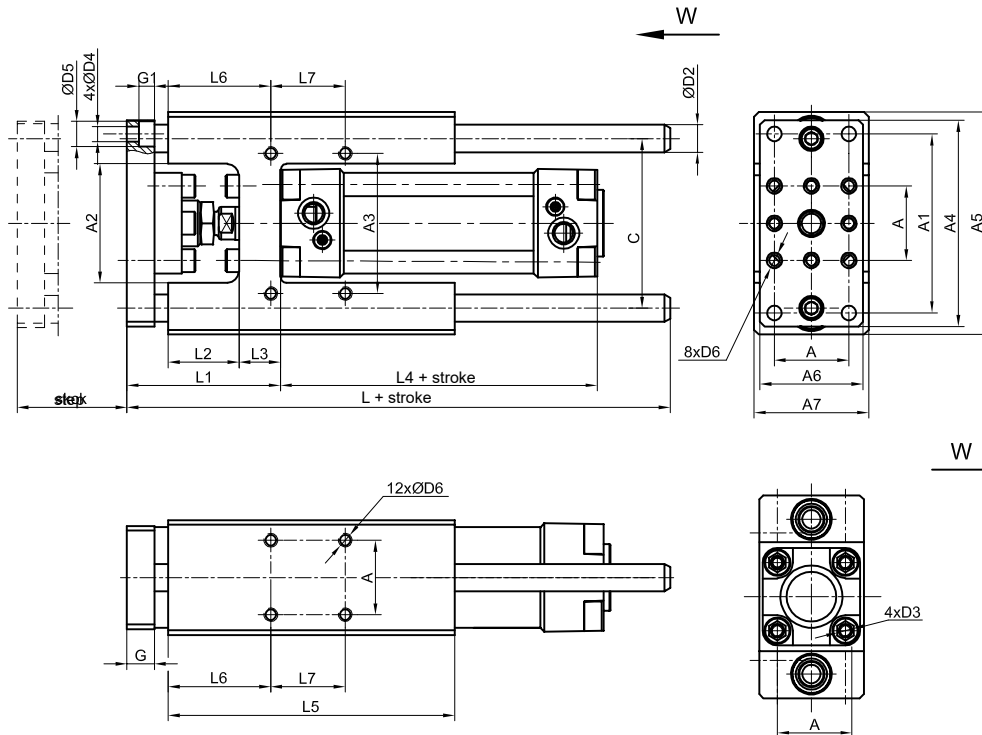

Cylinder diameter [mm]	Dimension [mm]																							
	A	A1	A2	A3	A4	A5	A6	A7	C	ØD2	D3	ØD4	ØD5	D6	G	G1	L	L1	L2	L3	L4	L5	L6	L7
32	32.5	78	52	61	90	97	45	50	74	12	M6	6.6	11	M6	12	6.5	177	67	31	18	94	125	44.7	32.5
40	38	84	58	69	110	115	54	58	87	16	M6	6.6	11	M6	12	6.5	192	75	37	22	105	140	48	38
50	46.5	100	70	85	130	137	63	70	104	20	M8	9	13	M8	15	9	237	89	45	26	106	150	52.5	46.5
63	56.5	105	86	100	145	152	80	85	119	20	M8	9	13	M8	15	9	237	89	45	26	121	182	55.7	56.5
80	72	130	106	130	180	189	100	105	148	25	M10	11	16.5	M10	20	11	280	111	55	32	128	215	66	72
100	89	150	130	150	200	213	120	130	172	25	M10	11	16.5	M10	20	11	280	116	56	36	138	220	67.5	89

\*Other stroke lengths manufactured after prior technical consultation.

# ACCESSORIES FOR CYLINDERS

## STK cylinder with guide



### U TYPE GUIDE

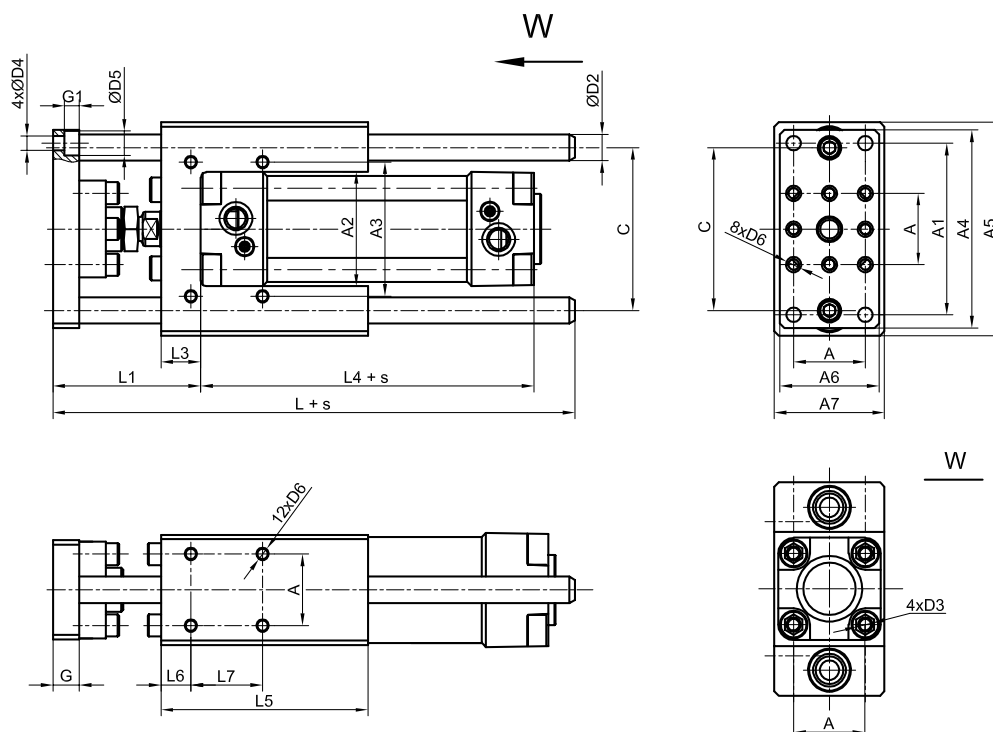

Cylinder diameter [mm]	Dimension [mm]																					
	A	A1	A2	A3	A4	A5	A6	A7	C	ØD2	ØD4	ØD5	D6	G	G1	L	L1	L3	L4	L5	L6	L7
32	32.5	78	52	61	90	97	45	50	74	12	6.6	11	M6	12	6.8	177	67	18	94	94	13.5	32.5
40	38	84	58	69	110	115	54	58	87	16	6.6	11	M6	12	6.8	192	75	22	105	103	10.5	38
50	46.5	100	70	85	130	137	63	70	104	20	9	15	M8	15	9	237	89	26	106	105	13	46.5
63	56.5	105	86	100	145	152	80	85	119	20	9	15	M8	15	9	237	89	26	121	137	13	56.5
80	72	130	106	130	180	189	100	105	148	25	11	18	M10	20	11	280	111	32	128	160	17	72
100	89	150	130	150	200	213	120	130	172	25	11	18	M10	20	11	280	116	36	138	164	19.5	89

Note: the technical data of the guide can be found on pages 1.17.03.01 and 1.17.03.03

### ORDER NUMBER CONSTRUCTION

**K1 . 016 H . 0500 . P K R**

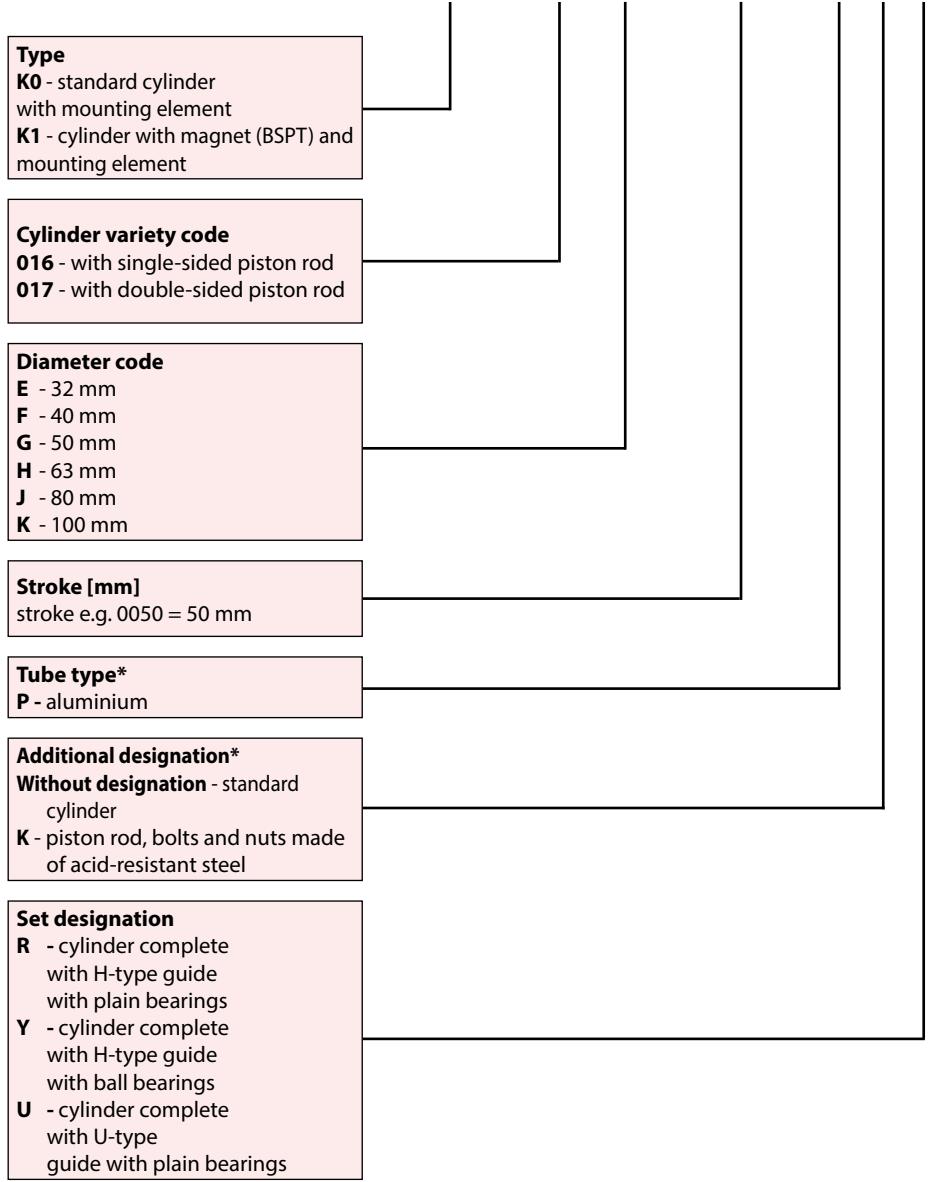

### ORDERING PROCEDURE

In your order, please specify: name, nominal diameter, stroke of the STK cylinder and the number of pieces, e.g.:

**Cylinder STK D16x500 K1.016H.0500.PKR with a guide 1 pc.**

\* Other versions after technical consultation



### TECHNICAL SPECIFICATIONS

<b>Maximum operating pressure:</b>	10 bar
<b>Medium:</b>	compressed air, filtered, lubricated or non-lubricated
<b>Contents of the set:</b>	- cylinder - lock
<b>Sealing:</b>	- polyurethane (working temperature from -20 to +80°C) - NBR
<b>Diameters:</b>	D32–D100
<b>Standard stroke range:</b>	5–500 mm*

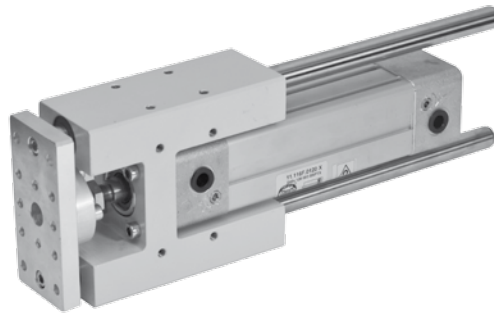

### H TYPE GUIDE

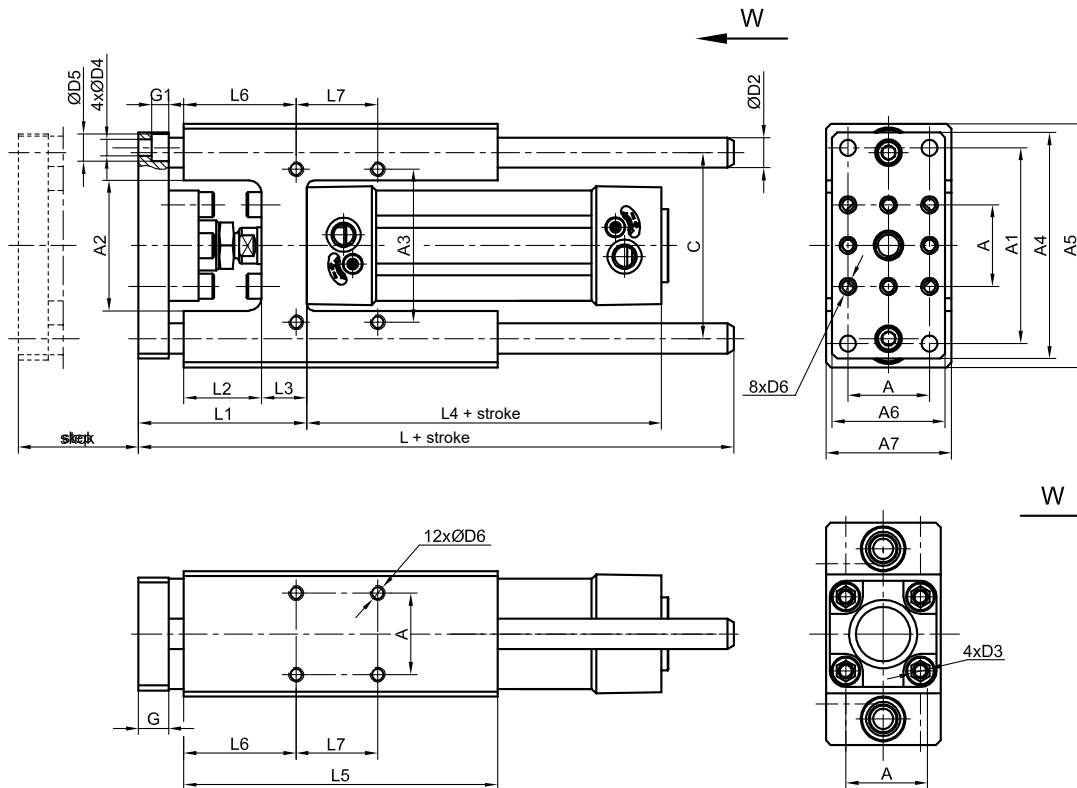

Cylinder diameter [mm]	Dimension [mm]																							
	A	A1	A2	A3	A4	A5	A6	A7	C	ØD2	D3	ØD4	ØD5	D6	G	G1	L	L1	L2	L3	L4	L5	L6	L7
32	32.5	78	52	61	90	97	45	50	74	12	M6	6.6	11	M6	12	6.5	177	67	31	18	94	125	44.7	32.5
40	38	84	58	69	110	115	54	58	87	16	M6	6.6	11	M6	12	6.5	192	75	37	22	105	140	48	38
50	46.5	100	70	85	130	137	63	70	104	20	M8	9	13	M8	15	9	237	89	45	26	106	150	52.5	46.5
63	56.5	105	86	100	145	152	80	85	119	20	M8	9	13	M8	15	9	237	89	45	26	121	182	55.7	56.5
80	72	130	106	130	180	189	100	105	148	25	M10	11	16.5	M10	20	11	280	111	55	32	128	215	66	72
100	89	150	130	150	200	213	120	130	172	25	M10	11	16.5	M10	20	11	280	116	56	36	138	220	67.5	89

\*Other stroke lengths manufactured after prior technical consultation.

# ACCESSORIES FOR CYLINDERS

## STE cylinder with guide



### U TYPE GUIDE

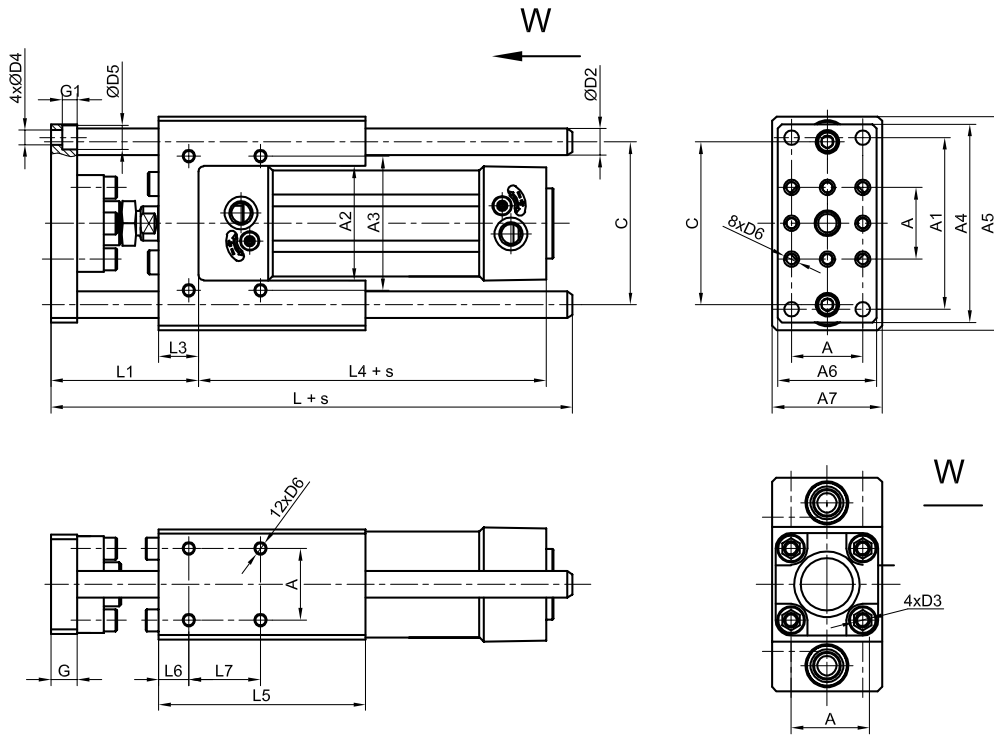

Cylinder diameter [mm]	Dimension [mm]																					
	A	A1	A2	A3	A4	A5	A6	A7	C	ØD2	ØD4	ØD5	D6	G	G1	L	L1	L3	L4	L5	L6	L7
32	32.5	78	52	61	90	97	45	50	74	12	6.6	11	M6	12	6.8	177	67	18	94	94	13.5	32.5
40	38	84	58	69	110	115	54	58	87	16	6.6	11	M6	12	6.8	192	75	22	105	103	10.5	38
50	46.5	100	70	85	130	137	63	70	104	20	9	15	M8	15	9	237	89	26	106	105	13	46.5
63	56.5	105	86	100	145	152	80	85	119	20	9	15	M8	15	9	237	89	26	121	137	13	56.5
80	72	130	106	130	180	189	100	105	148	25	11	18	M10	20	11	280	111	32	128	160	17	72
100	89	150	130	150	200	213	120	130	172	25	11	18	M10	20	11	280	116	36	138	164	19.5	89

Note: the technical data of the guide can be found on pages 1.17.03.01 and 1.17.03.03

### ORDER NUMBER CONSTRUCTION

**K1 . 116 H . 0500 . X K R**

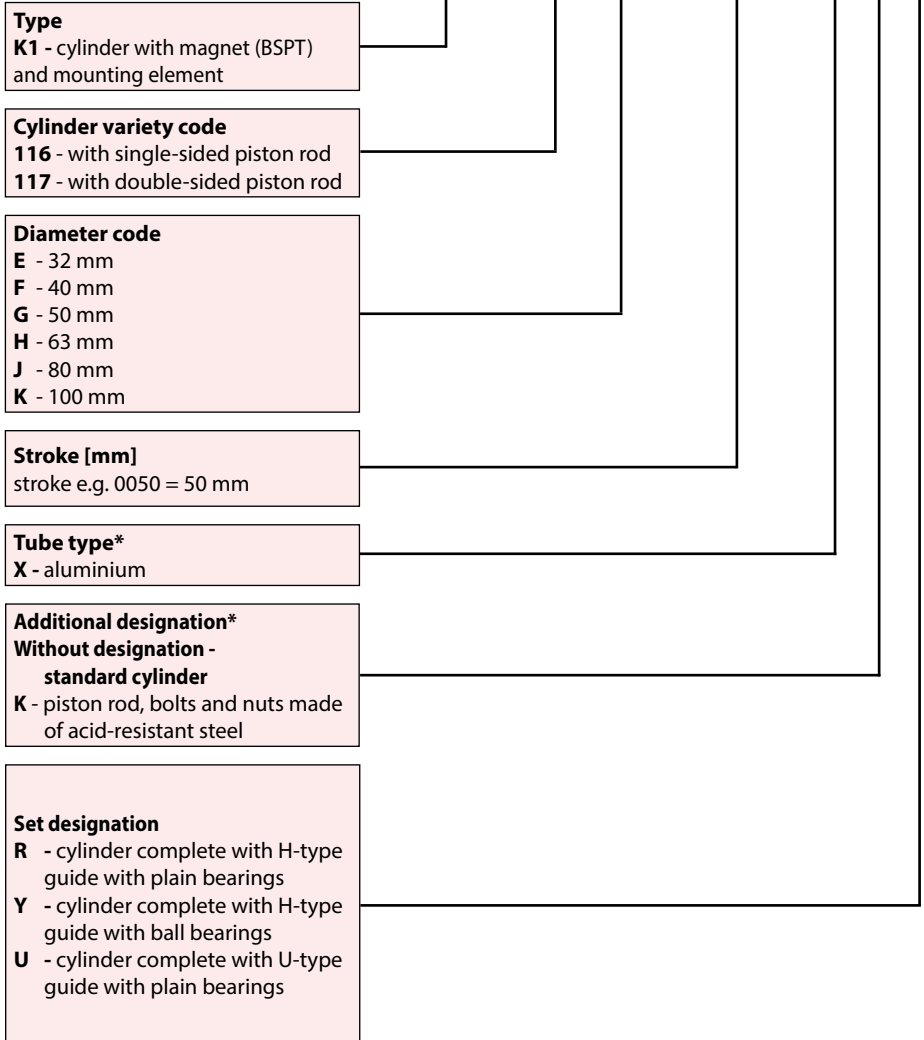

### ORDERING PROCEDURE

In your order, please specify: name, nominal diameter, stroke of the STE cylinder and the number of pieces, e.g.:

**Cylinder STE D63x500 K1.116H.0500.PKR with a guide 1 pc.**

\* Other versions after technical consultation





### TECHNICAL SPECIFICATIONS

<b>Maximum operating pressure:</b>	6 bar	
<b>Minimum supply pressure:</b>	- 2.5 bar when supplying the cylinder with air pressure 0 – 7.0 bar - 3.0 bar when supplying the cylinder with air pressure 7.0 – 10 bar	
<b>Medium:</b>	compressed air, filtered, lubricated	
<b>Type of lock:</b>	mechanical	
<b>Construction materials:</b>		
<b>Housing</b>	- aluminium alloy	
<b>Sealing</b>	-oil-resistant NBR rubber (working temp. from -5 to + 80°C)	



### LOCK FOR CYLINDERS ISO 6432 D20 –D25

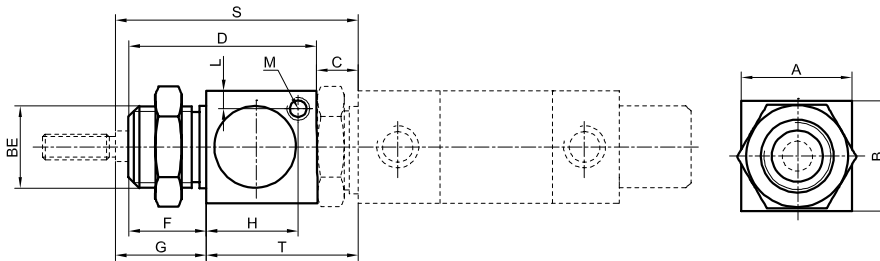

Cylinder diameter [mm]	Dimension [mm]												Weight [kg]
	A	B	BE E11	C	D	F	G	H	L	M	S	T	
20	34	35	M22x1.5	13	54	22	24	27	5	M5	69	45	0.19
25	34	35	M22x1.5	13	54	22	28	27	5	M5	73	45	0.19

**Note:** the lock is mounted on a piston rod cylinder longer than a standard cylinder by dimension T. Designation "B" at the end of the order number of the cylinder.

### LOCK FOR CYLINDERS ISO 6431 D32 –D125

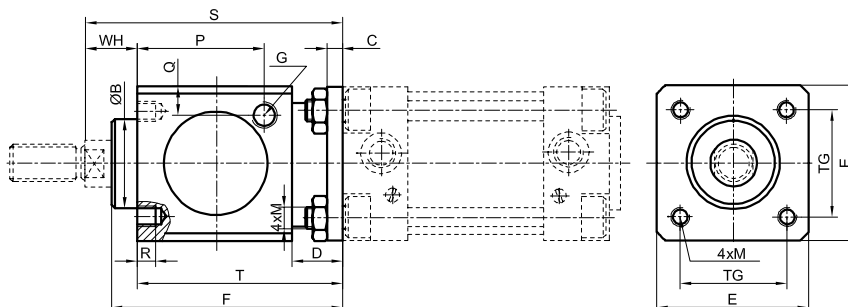

Cylinder diameter [mm]	Dimension [mm]														Weight [kg]
	ø B d11	C	D	E	M	G	F	P	Q	R	S	T	TG	WH	
32	30	6	20	47	4xM6	G1/8	67.5	33.5	9	8	86	60	32.5	26	0.4
40	35	6	20	54	4xM6	G1/8	80	42.5	9	8	100	70	38	30	0.6
50	40	8	24	65	4xM8	G1/8	100	58	12.5	12	127	90	46.5	37	1.1
63	45	8	24	75	4xM8	G1/8	100	59	17.5	12	127	90	56.5	37	1.5
80	45	12	32	95	4xM10	G1/4	120	69	17.5	16	156	110	72	46	2.6
100	55	12	32	114	4xM10	G1/4	120	69	27	16	161	110	89	51	3.5
125	60	20	45	138	4xM12	G1/4	156	84.5	19	20	205	140	110	65	6.5

**Note:** the lock is mounted on a piston rod cylinder longer than a standard cylinder by dimension T. Designation "B" at the end of the order number of the cylinder.

# ACCESSORIES FOR CYLINDERS

Piston rod lock  
for series SMI, SSI, STE and STK



## METHOD OF MOUNTING ON A PNEUMATIC CYLINDER

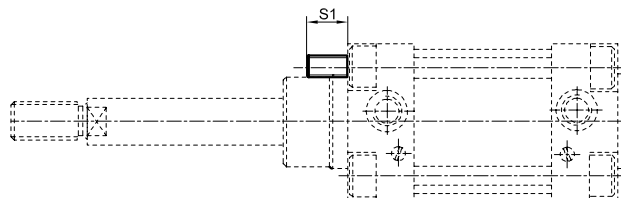

Cylinder diameter [mm]	32	40	50	63	80	100	125
<b>S1</b>	12	12	16	16	22	22	32

The pneumatic lock is mounted on the cylinder using 4 bolts screwed into the threaded hole in the special nut securing the cylinder. The required bolts length is provided in the table below. Mounting on the cylinder consists in connecting the air supply of approx. 0.3 MPa to the lock connection, sliding the lock on the cylinder piston rod and the protruding ends of the mounting bolts, and then locking with nuts. Bolts and nuts are sold complete with locks.

## CYLINDER PISTON ROD SUPPORT FORCES:

Cylinder diameter	20	25	32	40	50	63	80	100	125
<b>Piston rod support force [N]</b>	490	490	790	1240	1930	3060	5400	7700	12040

**Note:** the lock is mounted on a piston rod cylinder longer than a standard cylinder by dimension T. Designation "B" at the end of the order number of the cylinder.

## RECOMMENDED CONTROL METHODS

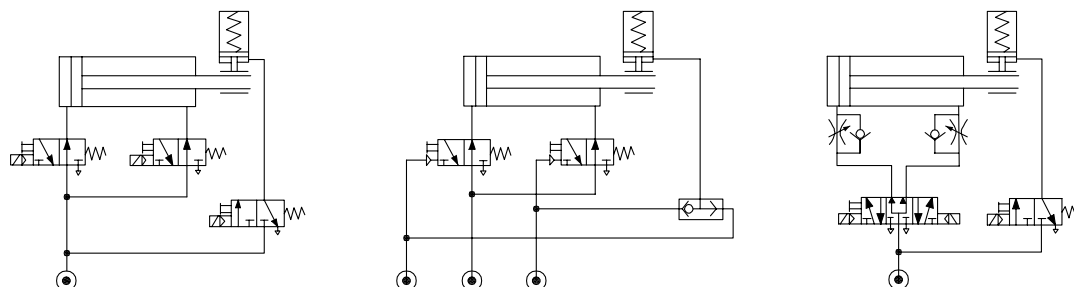

## ORDER NUMBER CONSTRUCTION

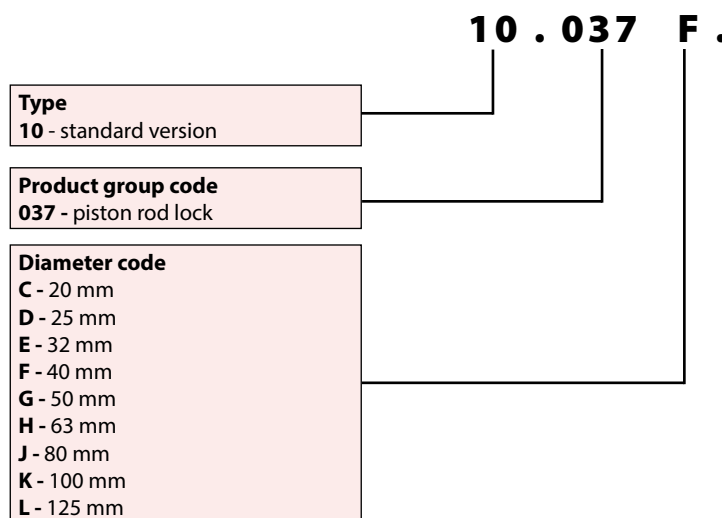

## ORDERING PROCEDURE

In your order, please specify: name, nominal diameter, order number of the lock and the number of pieces, e.g.:  
**Pneumatic lock no. 10.037H for SSI cylinder D63 1 pc.**

### TECHNICAL SPECIFICATIONS

<b>Maximum operating pressure:</b>	10 bar	
<b>Medium:</b>	compressed air, filtered, lubricated or non-lubricated	
<b>Contents of the set:</b>	- cylinder - lock	
<b>Sealing</b>	- polyurethane (working temperature from -20 to +80°C)	
<b>Diameters:</b>	- D20–D25	
<b>Standard stroke range:</b>	- 5–300 mm*	

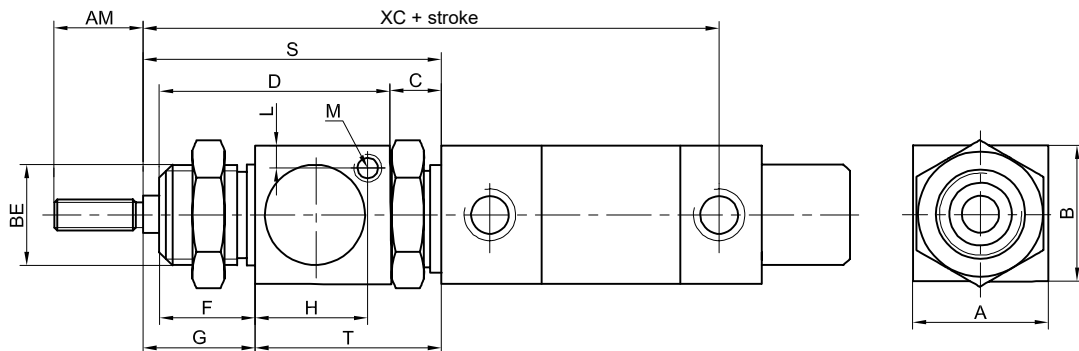

Cylinder diameter [mm]	Dimension [mm]													
	A	AM	B	BE E11	C	D	F	G	H	L	M	S	T	XC
20	34	20	35	M22x1.5	13	54	22	24	27	5	M5	69	45	95
25	34	22	35	M22x1.5	13	54	22	28	27	5	M5	73	45	104

\*Other stroke lengths manufactured after prior technical consultation.

# ACCESSORIES FOR CYLINDERS

## SMI mini-cylinder with lock



### ORDER NUMBER CONSTRUCTION

**K1 . 018 D . 0100 . A K B**

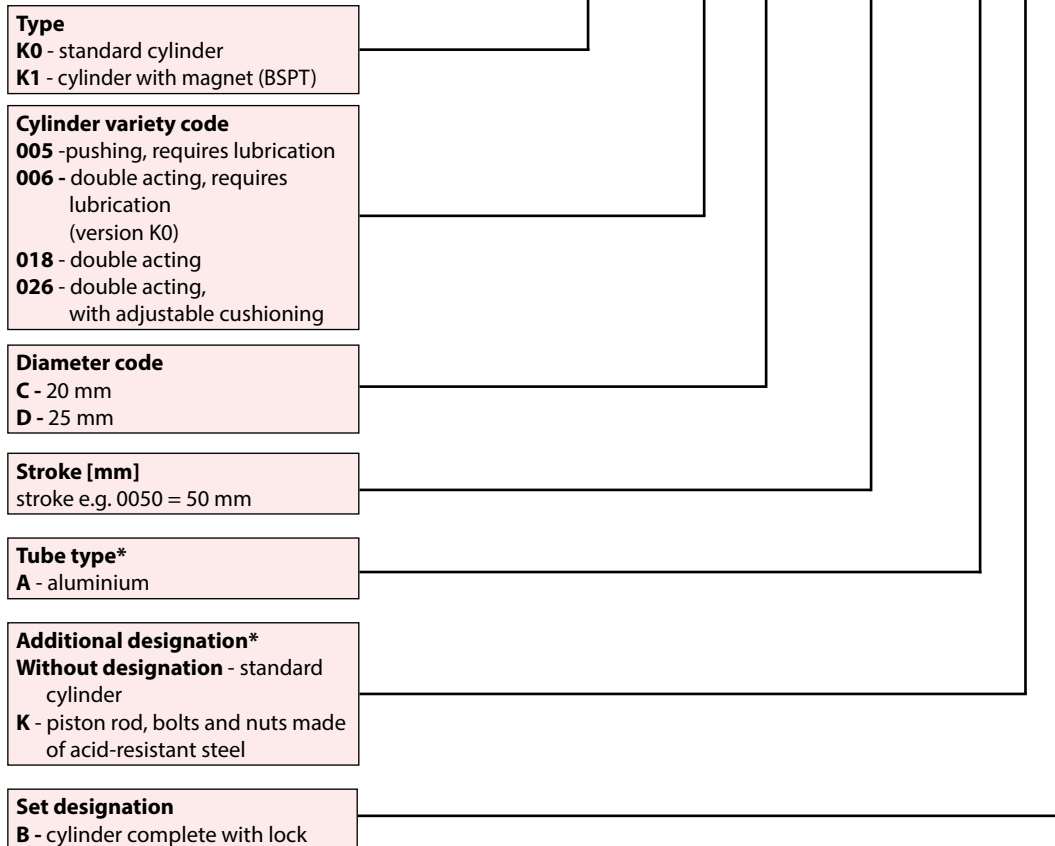

### ORDERING PROCEDURE

In your order, please specify: name, nominal diameter, stroke of SMI cylinder and the the number of pieces, e.g.:

**Mini-cylinder SMI D25x100 K1.018D.0100.AKB with lock 1 pc.**

\* Other versions after technical consultation

### TECHNICAL SPECIFICATIONS

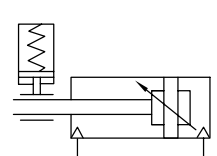
<b>Maximum operating pressure:</b>	10 bar	
<b>Medium:</b>	compressed air, filtered, lubricated or non-lubricated	
<b>Contents of the set:</b>	- cylinder - lock	
<b>Sealing:</b>	- polyurethane (working temperature from -20 to +80°C)	
<b>Diameters:</b>	D32-D125	
<b>Standard stroke range:</b>	5-500 mm*	

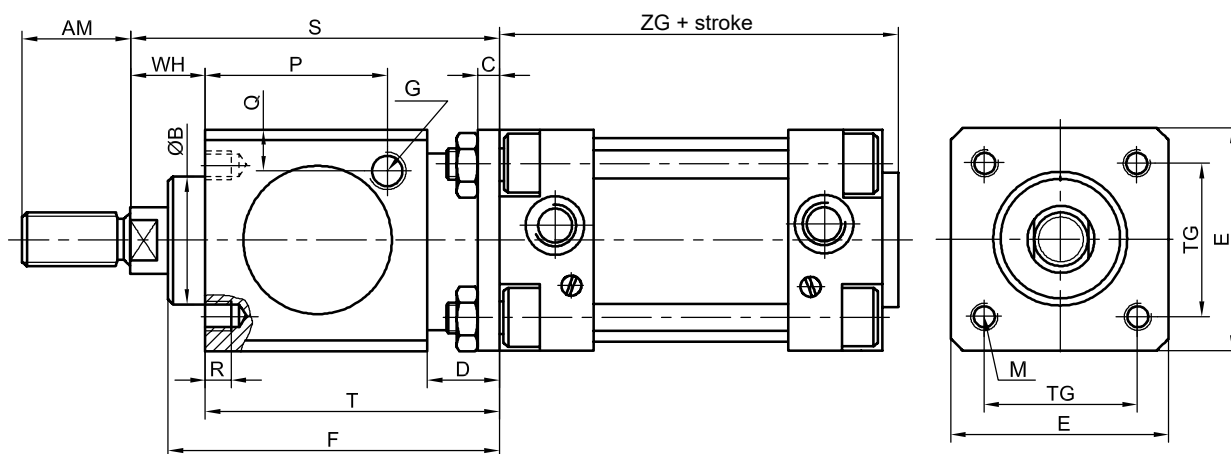

Cylinder diameter [mm]	Dimension [mm]															
	AM	Ø B d11	C	D	E	M	G	F	P	Q	R	S	T	TG	WH	ZG
32	22	30	6	20	47	4xM6	G1/8	67.5	33.5	9	8	86	60	32.5	26	94
40	24	35	6	20	54	4xM6	G1/8	80	42.5	9	8	100	70	38	30	105
50	32	40	8	24	65	4xM8	G1/8	100	58	12.5	12	127	90	46.5	37	106
63	32	45	8	24	75	4xM8	G1/8	100	59	17.5	12	127	90	56.5	37	121
80	40	45	12	32	95	4xM10	G1/4	120	69	17.5	16	156	110	72	46	128
100	40	55	12	32	114	4xM10	G1/4	120	69	27	16	161	110	89	51	138
125	54	60	20	45	138	4xM12	G1/4	156	84.5	19	20	205	140	110	65	160

\*Other stroke lengths manufactured after prior technical consultation.

# ACCESSORIES FOR CYLINDERS

SSI cylinders complete with locks



## ORDER NUMBER COMPOSITION

**K1 . 016 G . 0350 . A K B**

**Type**  
**K0** - standard cylinder  
**K1** - cylinder with magnet (BSPT)

**Cylinder variety code**  
**015** - TANDEM  
**016** - with single-sided piston rod  
**017** - with double-sided piston rod  
**416** - with single-sided piston rod and additional scraper  
**417** - with double-sided piston rod and additional scraper

**Diameter code**  
**E** - 32 mm  
**F** - 40 mm  
**G** - 50 mm  
**H** - 63 mm  
**J** - 80 mm  
**K** - 100 mm  
**L** - 125 mm

**Stroke [mm]**  
 stroke e.g. 0350 = 350 mm

**Tube type\***  
**Without designation** - steel  
**A** - aluminium  
**C** - chrome-plated steel

**Additional designation**  
**Without designation** - standard cylinder  
**K** - piston rod, bolts and nuts made of acid-resistant steel

**Set designation**  
**B** - cylinder complete with lock

## ORDERING PROCEDURE

In your order, please specify: name, nominal diameter, stroke of SSI cylinder and the the number of pieces, e.g.:

**SSI cylinder D50x350 K1.016G.0350.AKB with lock 1 pc.**

\* Other versions after technical consultation

### TECHNICAL SPECIFICATIONS

<b>Maximum operating pressure:</b>	10 bar	
<b>Medium:</b>	compressed air, filtered, lubricated or non-lubricated	
<b>Contents of the set:</b>	- cylinder - lock	
<b>Sealing:</b>	- polyurethane (working temperature from -20 to +80°C) - NBR	
<b>Diameters:</b>	D32–D100	
<b>Standard stroke range:</b>	5–500 mm*	

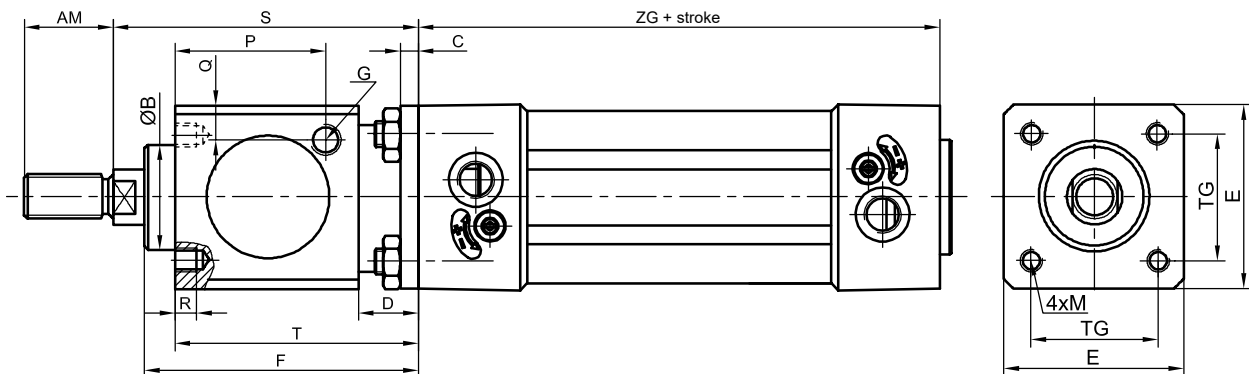
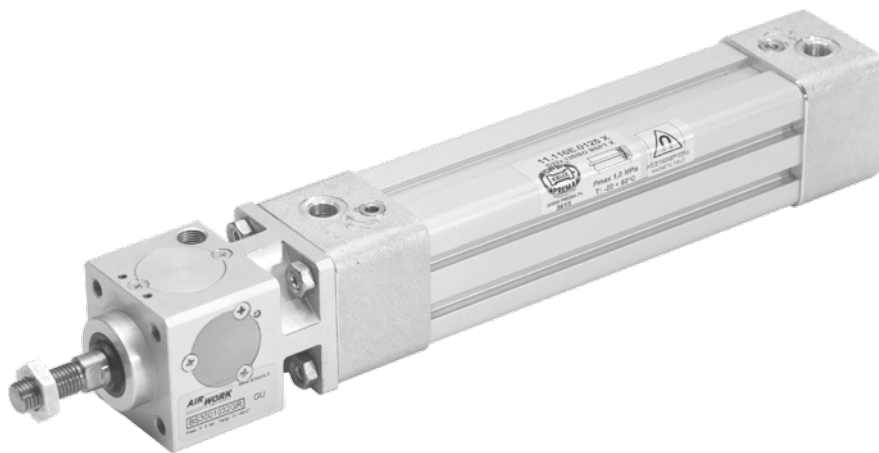

Cylinder diameter [mm]	Dimension [mm]														
	AM	Ø B d11	C	D	E	M	G	F	P	Q	R	S	T	TG	ZG
32	22	30	6	20	47	4xM6	G1/8	67.5	33.5	9	8	86	60	32.5	94
40	24	35	6	20	54	4xM6	G1/8	80	42.5	9	8	100	70	38	105
50	32	40	8	24	65	4xM8	G1/8	100	58	12.5	12	127	90	46.5	106
63	32	45	8	24	75	4xM8	G1/8	100	59	17.5	12	127	90	56.5	121
80	40	45	12	32	95	4xM10	G1/4	120	69	17.5	16	156	110	72	128
100	40	55	12	32	114	4xM10	G1/4	120	69	27	16	161	110	89	138
125	54	60	20	45	138	4xM12	G1/4	156	84.5	19	20	205	140	110	160

\*Other stroke lengths manufactured after prior technical consultation.



# ACCESSORIES FOR CYLINDERS

## STE cylinder complete with lock



### ORDER NUMBER CONSTRUCTION

1

**K1 . 116 H . 0500 . X K B**

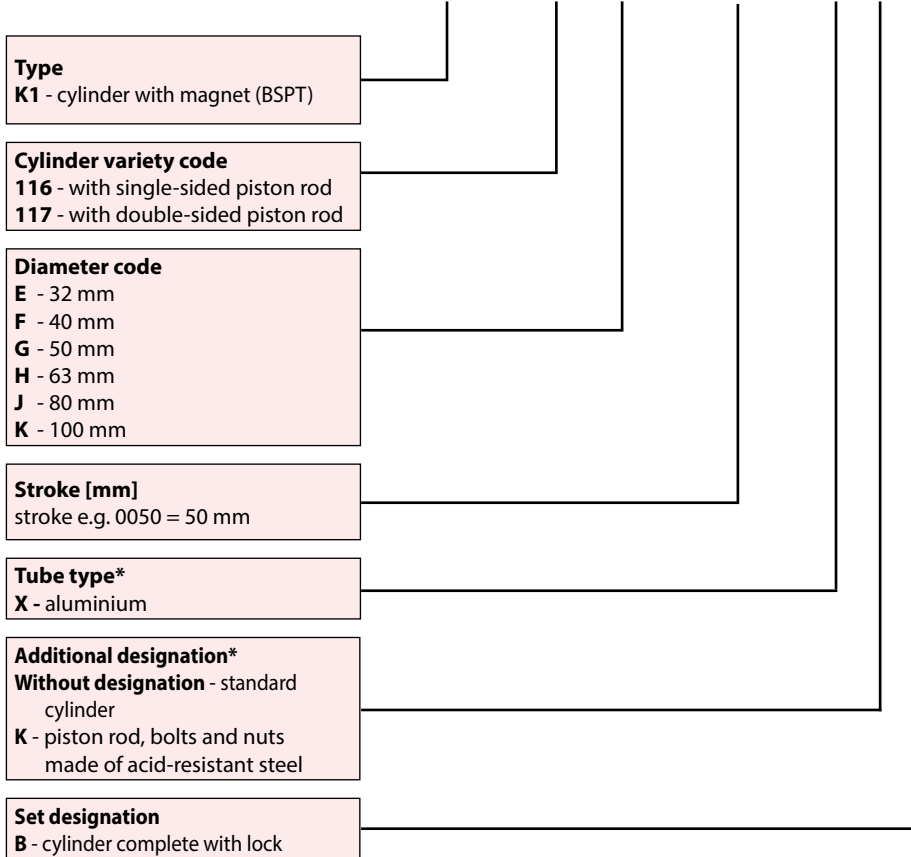

### ORDERING PROCEDURE

In your order, please specify: name, nominal diameter, stroke of the STE cylinder and the number of pieces, e.g.:

**STE cylinder D63x500 K1.116H.0500.PKB with lock 1 pc.**

\* Other versions after technical consultation

### TECHNICAL SPECIFICATIONS

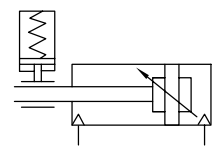
<b>Maximum operating pressure:</b> 10 bar	
<b>Medium:</b> compressed air, filtered, lubricated or non-lubricated	
<b>Contents of the set:</b> - cylinder - lock	
<b>Sealing:</b> - polyurethane (working temperature from -20 to +80°C) - NBR	
<b>Diameters:</b> D32-D100	
<b>Standard stroke range:</b> 5-500 mm*	

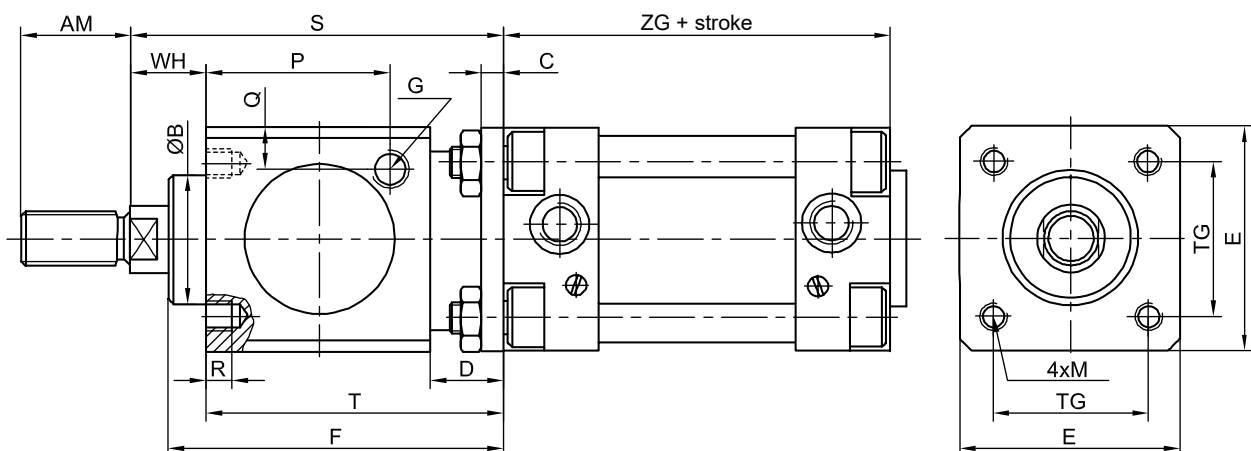
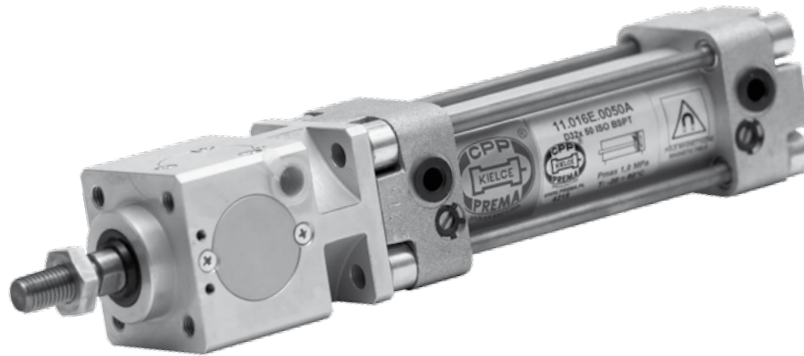

Cylinder diameter [mm]	Dimension [mm]															
	AM	Ø B d11	C	D	E	M	G	F	P	Q	R	S	T	TG	WH	ZG
32	22	30	6	20	47	4xM6	G1/8	67.5	33.5	9	8	86	60	32.5	26	94
40	24	35	6	20	54	4xM6	G1/8	80	42.5	9	8	100	70	38	30	105
50	32	40	8	24	65	4xM8	G1/8	100	58	12.5	12	127	90	46.5	37	106
63	32	45	8	24	75	4xM8	G1/8	100	59	17.5	12	127	90	56.5	37	121
80	40	45	12	32	95	4xM10	G1/4	120	69	17.5	16	156	110	72	46	128
100	40	55	12	32	114	4xM10	G1/4	120	69	27	16	161	110	89	51	138

\*Other stroke lengths manufactured after prior technical consultation.

# ACCESSORIES FOR CYLINDERS

STK cylinder complete with lock



## ORDER NUMBER CONSTRUCTION

**K1 . 016 H . 0500 . P K B**

**Type**  
K1 - cylinder with magnet (BSPT)

**Cylinder variety code**  
016 - with single-sided piston rod  
017 - with double-sided piston rod

**Diameter code**  
E - 32 mm  
F - 40 mm  
G - 50 mm  
H - 63 mm  
J - 80 mm  
K - 100 mm

**Stroke [mm]**  
stroke e.g. 0050 = 50 mm

**Tube type\***  
P - aluminium

**Additional designation\***  
K - piston rod, bolts and nuts made of acid-resistant steel

**Set designation**  
B - cylinder complete with lock

## ORDERING PROCEDURE

In your order, please specify: name, nominal diameter, stroke of the STK cylinder and the number of pieces, e.g.:

**STK cylinder D63x500 K1.016H.0500.PKB with lock 1 pc.**

\* Other versions after technical consultation

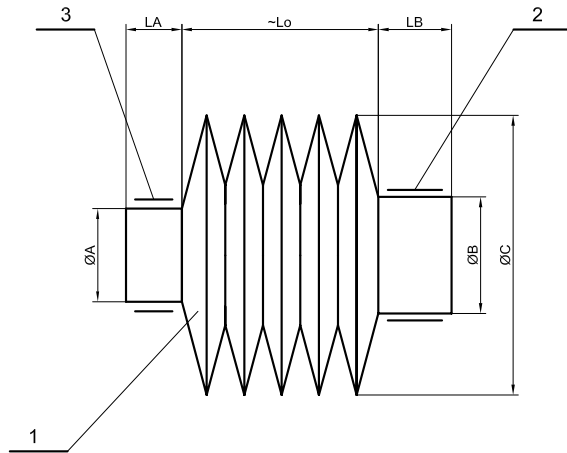

pos.1 - piston rod cover  
pos.2.3 - cable ties (incl. cover)

Cylinder diameter	Dimension [mm]					Working stroke range of the cylinder [mm] S	Length of the cover Lo	Extension of the piston rod F	Cover order number
	øA	øB	øC	LA	LB				
32	12.5	29.5	65	10	10	0 - 100	15	25	19.016E.21.0100
						101 - 200	30	40	19.016E.21.0200
						201 - 300	45	55	19.016E.21.0300
						301 - 400	60	70	19.016E.21.0400
						401 - 500	75	85	19.016E.21.0500
40	16.5	34.5	70	10	15	0 - 100	15	25	19.016F.21.0100
						101 - 200	30	40	19.016F.21.0200
						201 - 300	45	55	19.016F.21.0300
						301 - 400	60	70	19.016F.21.0400
						401 - 500	75	85	19.016F.21.0500
50	20.5	39	82	15	15	0 - 150	15	25	19.016H.21.0150
						151 - 300	30	40	19.016H.21.0300
63	20.5	39	82	15	15	301 - 450	45	55	19.016H.21.0450
						451 - 600	60	70	19.016H.21.0600
						601 - 750	75	85	19.016H.21.0750
80	25.5	46.5	90	15	20	0 - 150	15	25	19.016K.21.0150
						151 - 300	30	40	19.016K.21.0300
						301 - 450	45	55	19.016K.21.0450
						451 - 600	60	70	19.016K.21.0600
						601 - 750	75	85	19.016K.21.0750
100	25.5	46.5	90	15	20	0 - 150	15	25	19.016K.21.0150
						151 - 300	30	40	19.016K.21.0300
						301 - 450	45	55	19.016K.21.0450
						451 - 600	60	70	19.016K.21.0600
						601 - 750	75	85	19.016K.21.0750
125	32.5	57.5	101	20	20	0 - 150	15	20	19.016L.21.0150
						151 - 300	30	35	19.016L.21.0300
						301 - 450	45	50	19.016L.21.0450
						451 - 600	60	65	19.016L.21.0600
						601 - 750	75	80	19.016L.21.0750
160	40.5	64	130	20	20	0 - 250	15	15	19.016M.21.0250
						251 - 500	30	30	19.016M.21.0500
						501 - 750	45	45	19.016M.21.0750
						751 - 1000	60	60	19.016M.21.1000
						1001 - 1250	75	75	19.016M.21.1250
200	40.5	70.5	136	20	20	0 - 250	15	0	19.016N.21.0250
						251 - 500	30	15	19.016N.21.0500
						501 - 750	45	30	19.016N.21.0750
						751 - 1000	60	45	19.016N.21.1000
						1001 - 1250	75	60	19.016N.21.1250
250	50.5	84.5	150	20	20	0 - 250	15	20	19.016P.21.0250
						251 - 500	30	35	19.016P.21.0500
						501 - 750	45	50	19.016P.21.0750
						751 - 1000	60	65	19.016P.21.1000
						1001 - 1250	75	80	19.016P.21.1250
320	63.5	101	166	20	20	0 - 250	15	20	19.016R.21.0250
						251 - 500	30	35	19.016R.21.0500

### ORDERING PROCEDURE

In your order, please specify: name, nominal diameter, stroke of SSI cylinder used with the cover, order number for the cover and the number of pieces, e.g.

**Piston rod cover no. 19.016H.21.0100 for SSI series cylinder D63 x 100 1 pc.**

**Note:** is using an ISO cylinder with cover, you must order it with the piston rod extended by dimension F (shown in the table)  
Enter designation "S" at the end of the order number of the cylinder.



## MAGNETIC FIELD SENSOR FOR T-TYPE GROOVE

<b>Switching function:</b>	- Normally open contact (NO)
<b>Switch output:</b>	- PNP
<b>Rated operating voltage Ue:</b>	- 24 VDC (10V-30V)
<b>Measurement operating current:</b>	- 200 mA
<b>Type of plug:</b>	- M8x1-S49
<b>Protection class acc. to IEC 60529:</b>	- IP67
<b>Conduit length:</b>	- 0.30 m
<b>Cable jacket material:</b>	- PUR
<b>Ambient temperature range:</b>	- 25°C to +85°C
<b>Operation indicator:</b>	- yes
<b>Reverse polarity protection:</b>	- yes
<b>Short-circuit protection:</b>	- yes

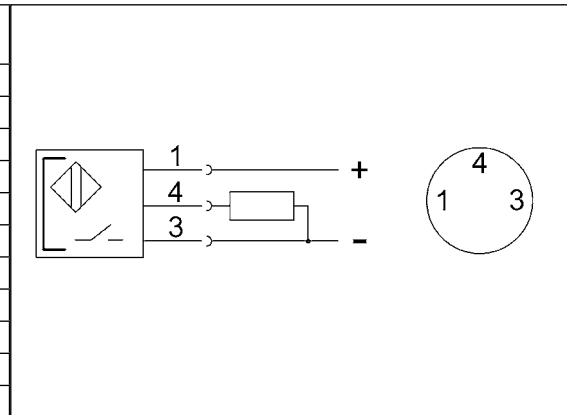

Order number
17.10C4.01

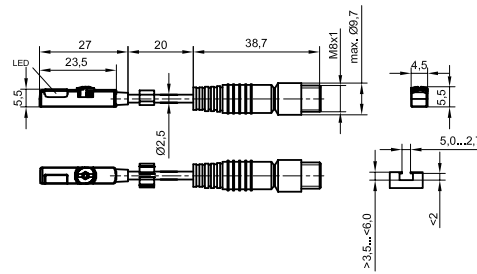

## MAGNETIC FIELD SENSOR FOR T-TYPE GROOVE

<b>Switching function:</b>	- Normally open contact (NO)
<b>Switch output:</b>	- PNP
<b>Rated operating voltage Ue:</b>	- 24 VDC (10V-30V)
<b>Measurement operating current:</b>	- 200 mA
<b>Connection type:</b>	- cable
<b>Protection class acc. to IEC 60529:</b>	- IP67
<b>Conduit length:</b>	- 2.00 m
<b>Cable jacket material:</b>	- PUR
<b>Ambient temperature range:</b>	- 25°C to +85°C
<b>Operation indicator:</b>	- yes
<b>Reverse polarity protection:</b>	- yes
<b>Short-circuit protection:</b>	- yes

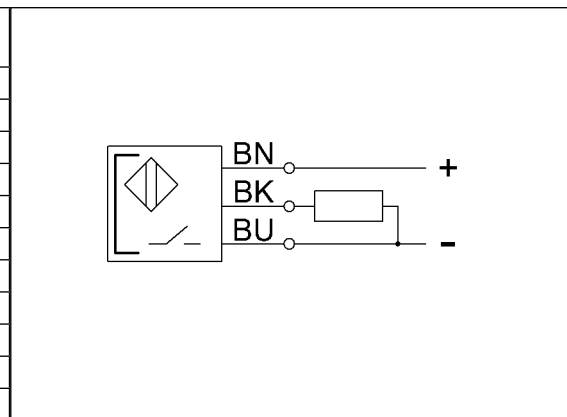

Order number
17.10AR.01

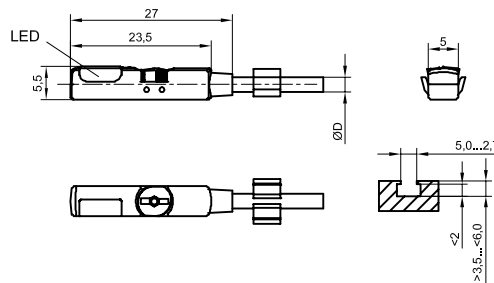

# ACCESSORIES FOR CYLINDERS

magnetic field sensors



## MAGNETIC FIELD SENSOR FOR C-TYPE GROOVE

<b>Switching function:</b>	- Normally open contact (NO)	
<b>Switch output:</b>	- PNP	
<b>Rated operating voltage Ue:</b>	-24 VDC (10V-30V)	
<b>Measurement operating current:</b>	-100 mA	
<b>Connection type:</b>	- cable	
<b>Protection class acc. to IEC 60529:</b>	-IP67	
<b>Conduit length:</b>	-2.00 m	
<b>Cable jacket material:</b>	-PUR	
<b>Ambient temperature range:</b>	-25°C to +85°C	
<b>Operation indicator:</b>	- yes	
<b>Reverse polarity protection:</b>	- yes	
<b>Short-circuit protection:</b>	- yes	

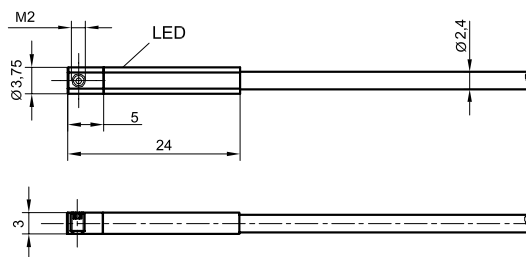

Order number
17.10EF.01

## MAGNETIC FIELD SENSOR FOR C-TYPE GROOVE

<b>Switching function:</b>	- Normally open contact (NO)	
<b>Switch output:</b>	- PNP	
<b>Rated operating voltage Ue:</b>	-24 VDC (10V-30V)	
<b>Measurement operating current:</b>	-100 mA	
<b>Type of plug:</b>	-M8x1-S49	
<b>Protection class acc. to IEC 60529:</b>	-IP67	
<b>Conduit length:</b>	-0.30 m	
<b>Cable jacket material:</b>	-PUR	
<b>Ambient temperature range:</b>	-25°C to +85°C	
<b>Operation indicator:</b>	- yes	
<b>Reverse polarity protection:</b>	- yes	
<b>Short-circuit protection:</b>	- yes	

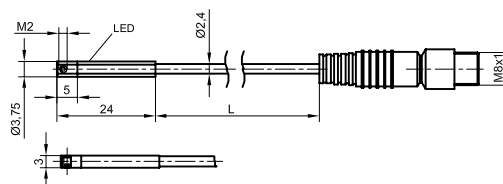

Order number
17.10EL.01

## MAGNETIC FIELD SENSOR FOR TRAPEZOIDAL GROOVE - SET

Order number
17.1000.01

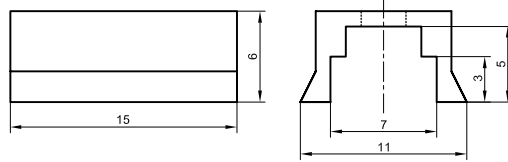

Order number
17.1000.02

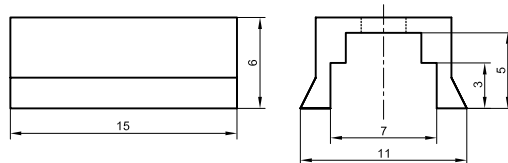

The set includes adapter for trapezoidal groove and sensor for T-type groove

## NON-STANDARD ELEMENTS

### UNIVERSAL REED SWITCH SENSOR

<b>Switching function:</b> - Normally open contact (NO)	
<b>Rated operating voltage Ue:</b> -6 to 240 V AC/DC	
<b>Maximum current:</b> -128 mA (24 V), 86 mA (115 V), 41 mA (230 V)	
<b>Connection type:</b> - cable	
<b>Protection class acc. to IEC 60529:</b> -IP65	
<b>Conduit length:</b> -3.00 m	
<b>Cable jacket material:</b> -PVC	
<b>Ambient temperature range:</b> -25°C to +70°C	
<b>Operation indicator:</b> - yes	
<b>Reverse polarity protection:</b> - yes	
<b>Short-circuit protection:</b> - no	

Order number
17.51BC.03

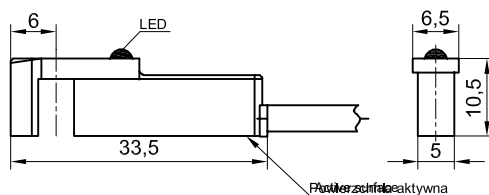



### MAGNETIC FIELD SENSOR FOR T-TYPE GROOVE

<b>Switching function:</b>	- Normally open contact (NO)
<b>Switch output:</b>	- NPN
<b>Rated operating voltage <math>U_e</math>:</b>	- 24 VDC (10V - 30V)
<b>Measurement operating current:</b>	- 100 mA
<b>Connection type:</b>	- cable
<b>Protection class acc. to IEC 60529:</b>	- IP67
<b>Conduit length:</b>	- 2.00 m
<b>Cable jacket material:</b>	- PUR
<b>Ambient temperature range:</b>	-25°C to +85°C
<b>Operation indicator:</b>	- yes
<b>Reverse polarity protection:</b>	- yes
<b>Short-circuit protection:</b>	- yes

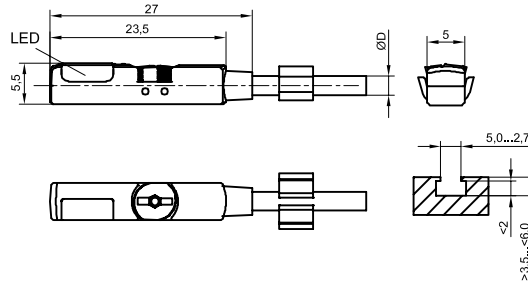
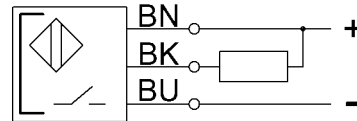

Order number
17.10AU.02

### HEAT RESISTANT MAGNETIC FIELD SENSOR

<b>Switching function:</b>	- Normally open contact (NO)
<b>Switch output:</b>	- PNP
<b>Rated operating voltage <math>U_e</math>:</b>	- 24 VDC (10V-30V)
<b>Measurement operating current:</b>	- 200 mA
<b>Connection type:</b>	- cable
<b>Protection class acc. to IEC 60529:</b>	- IP67
<b>Conduit length:</b>	- 2.00 m
<b>Cable jacket material:</b>	- PUR
<b>Ambient temperature range:</b>	-25°C to +105°C
<b>Operation indicator:</b>	- no
<b>Reverse polarity protection:</b>	- yes
<b>Short-circuit protection:</b>	- yes

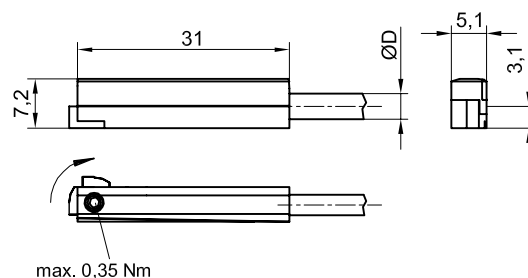
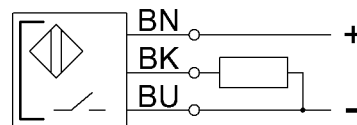

Order number
17.107U.02

## MAGNETIC FIELD SENSOR FOR USE IN POTENTIALLY EXPLOSIVE ATMOSPHERES

<b>Switching function:</b>	- Normally open contact (NO)
<b>Rated operating voltage Ue:</b>	-8.2 VDC (max. 13.2V)
<b>Measurement operating current:</b>	-100 mA
<b>Connection type:</b>	- cable
<b>Protection class acc. to IEC 60529:</b>	-IP67
<b>Conduit length:</b>	-6.00 m
<b>Cable jacket material:</b>	-PVC
<b>Ambient temperature range:</b>	-25°C to +70°C
<b>Operation indicator:</b>	- yes

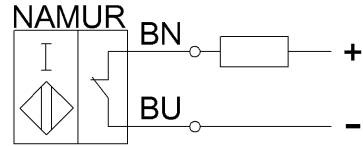

Order number
17.10E4.02*

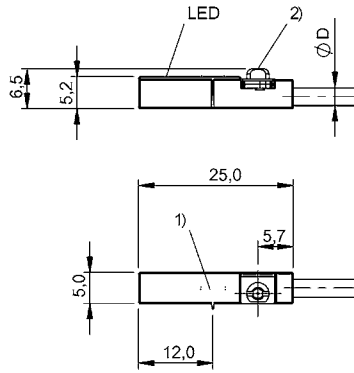

## SEPARATOR

<b>Input:</b>	NAMUR
<b>Relay output:</b>	-maximum voltage: 250 V AC -maximum current: 4 A AC
<b>Power supply voltage:</b>	-24 V DC
<b>Ambient temperature range:</b>	-20°C to +60°C

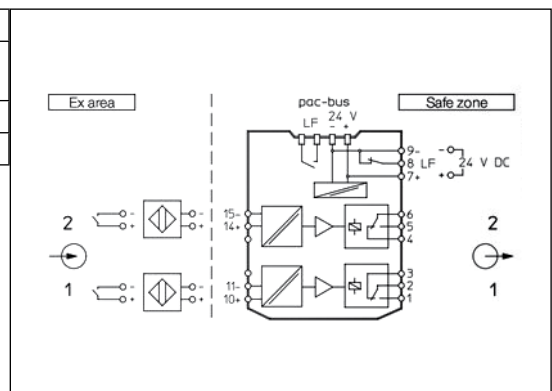

Order number
17.104P.02*

\* The magnetic field sensor for potentially explosive atmospheres must be used together with the separator.

# ACCESSORIES FOR CYLINDERS

## magnetic field sensors



### MOUNTING ELEMENTS

Mounting brackets for magnetic field sensors			
Series	Piston diameter	Order number	Tube design, dimensions
SSI SCN	D32 - D125	17.11M9.01	<p>ROUND TUBE</p>
	D160 - D250	17.11MC.01	<p>ROUND TUBE</p>
STK	D32 - D100	17.11MA.01	<p>SHAPED TUBE</p>
SDK	D16 - D100	17.1000.01* 17.1000.02*	<p>TRAPEZOIDAL CHANNEL</p>
SKP	D12 - D100	17.11LN.01	<p>T-CHANNEL</p>
		<b>Tie no.</b>	<b>Bracket no.</b>
SMI	D12	17.11N3.01	
	D16		
D20	17.11N4.01		
D25			
Cylinder for guide	D25	17.11N5.01	
	D40	17.11N6.01	
	D50	17.11N7.01	
	D63	17.11N8.01	
	D80	17.11N9.01	
	D100	17.10BZ.K	

\* the set includes adapter for trapezoidal groove and sensor for T-type groove

## MOUNTING ELEMENTS

Groove types in pneumatic cylinder tubes		
Groove type	Series	Compatible sensor no.
T-type groove	STE SKP	17.10C4.01
		17.10AR.01
		17.10AU.02
		17.107U.02
		17.10E4.02
		"17.51BC.03 with mount 17.11LN.01"
C-type groove	CPKB rodless cylinders	17.10EF.01
		17.10EL.01
Trapezoidal groove	SDK	17.1000.01
		17.1000.02

For other cylinder series, it is possible to mount the sensor compatible with the T-type groove together with the mount according to the table from page 1.17.06.06.06

# ACCESSORIES FOR CYLINDERS

## magnetic field sensors



### ACCESSORIES

1

PLUG	
Type of plug:	- straight
Conduit length:	- 5 m
Connection thread:	- M8x1
Order number:	- 17.11NW.02

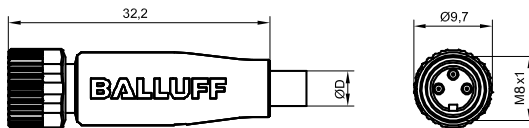

PLUG	
Type of plug:	- straight
Conduit length:	- 10 m
Connection thread:	- M8x1
Order number:	- 17.11NY.02

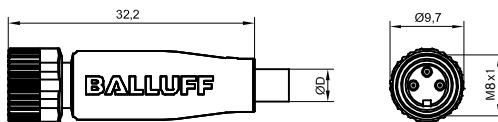

PLUG	
Type of plug:	- angled
Conduit length:	- 5 m
Connection thread:	- M8x1
Order number:	- 17.11P6.02

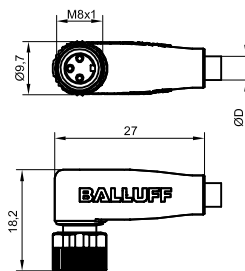

PLUG	
Type of plug:	- angled
Conduit length:	- 10 m
Connection thread:	- M8x1
Order number:	- 17.11P7.02

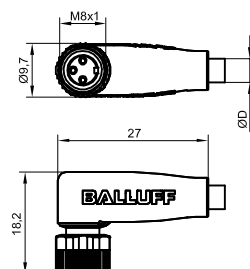

## VARIETY 11.005

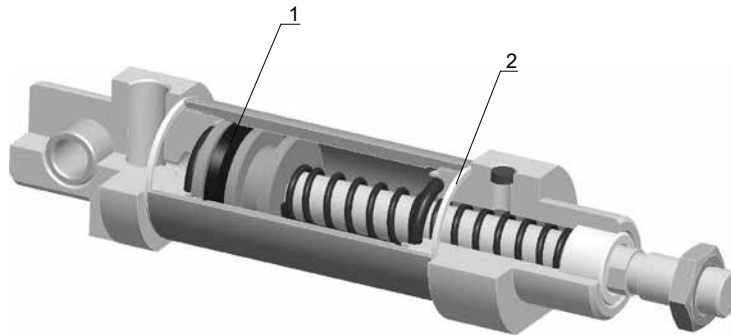

Position		1	2	Repair kit number
Spare part name		Piston gasket	Sealing washer	
Diameter D of the cylinder	D12	19.006A.04	19.006A.08	<b>19.005A.KN</b>
	D16	19.006B.04	19.006B.08	<b>19.005B.KN</b>
	D20	19.006C.04	19.006C.08	<b>19.005C.KN</b>
	D25	19.006D.04	19.006D.07	<b>19.005D.KN</b>
<b>Number of pieces in the cylinder</b>				
with a single-sided piston rod		1	2	1

## VARIETY 11.006

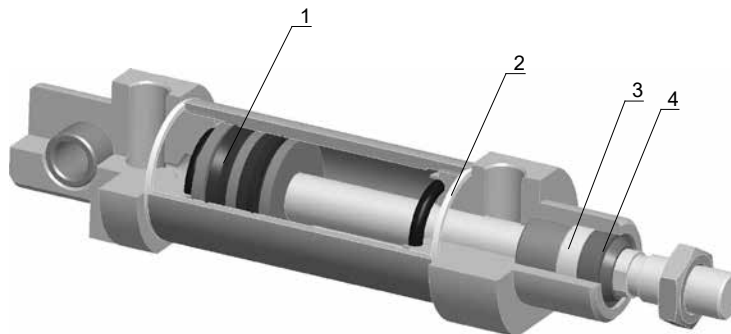

Position		1	2	3	4	Repair kit number
Spare part name		Piston gasket	Sealing washer	Piston rod gasket	Seal wiper ring	
Diameter D of the cylinder	D12	19.006A.04	19.006A.08	19.006B.05	19.0004.0007	<b>19.006A.KN</b>
	D16	19.006B.04	19.006B.08	19.006B.05		<b>19.006B.KN</b>
	D20	19.006C.04	19.006C.08	19.006D.05	19.0004.0004	<b>19.006C.KN</b>
	D25	19.006D.04	19.006D.07	19.006D.05		<b>19.006D.KN</b>
<b>Number of pieces in the cylinder</b>						
with a single-sided piston rod		2	2	1	1	1

## ORDERING PROCEDURE

In your order, please specify: name of the spare part or repair kit, order number and the number of pieces, e.g.:

**Sealing washer for SMI cylinder No. 19.006B.08 1 pc.**

# REPAIR KITS

## for SMI cylinders



### VARIETY 11.018

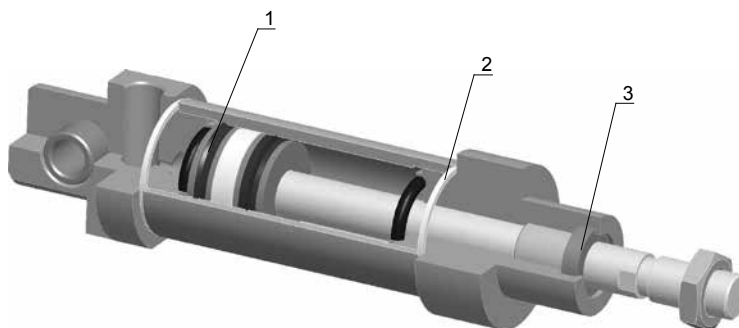

Position		1	2	3	Repair kit number
Spare part name		Piston gasket	Sealing washer	Guide ring	
Diameter D of the cylinder	D12	19.018A.04	19.006A.08	19.018B.05	19.018A.KN
	D16	19.018B.04	19.006B.08		19.018B.KN
	D20	19.018C.04	19.006C.08	19.018D.05	19.018C.KN
	D25	19.018D.04	19.006D.07		19.018D.KN
<b>Number of pieces in the cylinder</b>					
with a single-sided piston rod		2	1	1	1

### VARIETY 11.026

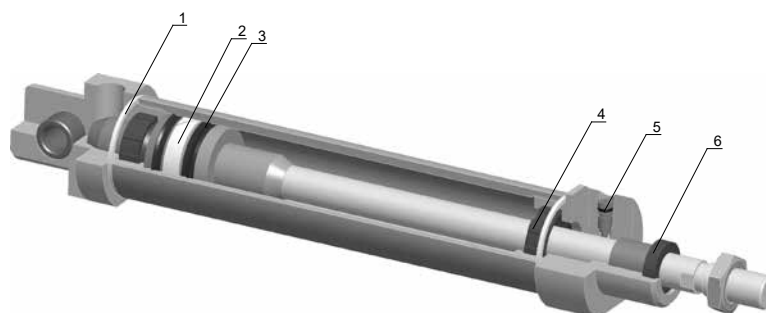

Position		1	2	3	4	5	6	Repair kit number
Spare part name		Washer	Guide ring	Piston gasket	Cushioning gasket	O-ring for absorber gland	Piston rod gasket	
Diameter D of the cylinder	D20	19.006C.08	13.013C.011	19.018C.04	19.026C.09	19.0001.0033	19.026C.05	19.026C.KN
	D25	19.006D.08	13.013D.01	19.018D.04	19.026D.09	19.0001.0033	19.018D.05	19.026D.KN
<b>Number of pieces in the cylinder</b>								
with a single-sided piston rod		2	1	2	2	2	1	1

### ORDERING PROCEDURE

In your order, please specify: name of the spare part or repair kit, order number and the number of pieces, e.g.:

**Piston rod gasket for SMI cylinder no. 19.018D.05 1 pc.**

## VARIETY 11.226 / 227

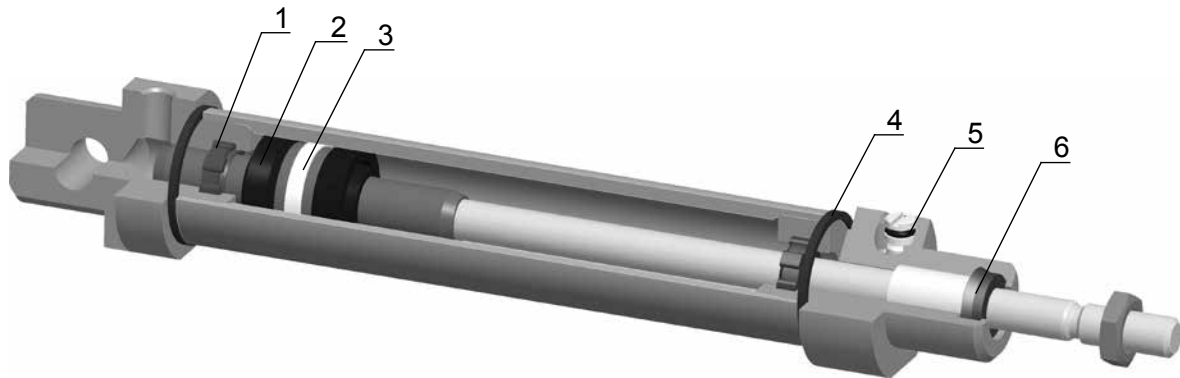

Position	1	2	3	4	5*	6	Repair kit number	
Spare part name	Cushioning gasket	Piston gasket	Guide ring	O-ring	O-ring for absorber gland	Piston rod gasket		
Diameter D of the cylinder	D12**	-	19.227A.04	-	19.227A.08	-	19.227A.05	<b>19.227A.KN</b>
	D16	19.226B.09	19.227B.04	-	19.227B.08	19.226B.10	19.227B.05	<b>19.226B.KN</b>
	D20	19.226C.09	19.227C.04	-	19.227C.08		19.227C.05	<b>19.226C.KN</b>
	D25	19.226D.09	19.227D.04	19.227D.07	19.227D.08		19.227D.05	<b>19.226D.KN</b>
<b>Number of pieces in the cylinder</b>								
with a single-sided piston rod	2	2	2	2	1	1	1	

## ORDERING PROCEDURE

In your order, please specify: name of the spare part or repair kit, order number and the number of pieces, e.g.:

**Piston rod gasket for SMI cylinder no. 19.227A.05 1 pc.**

\* does not occur in cylinder variety 11.217... (version without cushioning)

\*\* does not occur in cylinder variety 11.226... (version with cushioning)



## VARIETY 11.008

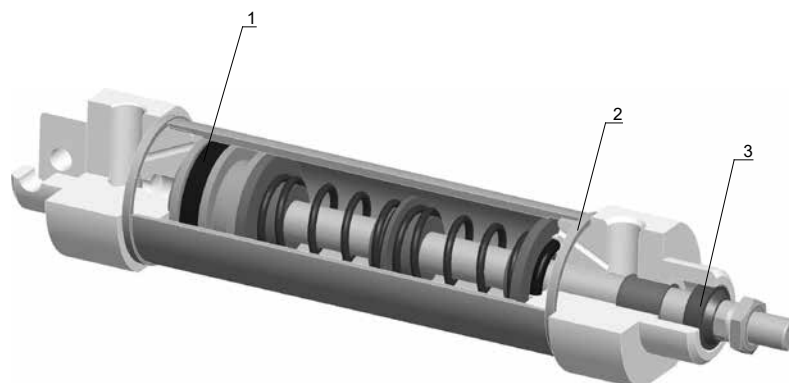

Position		1	2	3	Repair kit number
Spare part name		Piston gasket	Sealing washer	Seal wiper ring	
Diameter D of the cylinder	D 32	19.010E.04	19.010E.08	19.0004.0004	10.008E.KN
<b>Number of pieces in the cylinder</b>					
with single-sided piston rod		1	2	1	1

## VARIETY 11.009

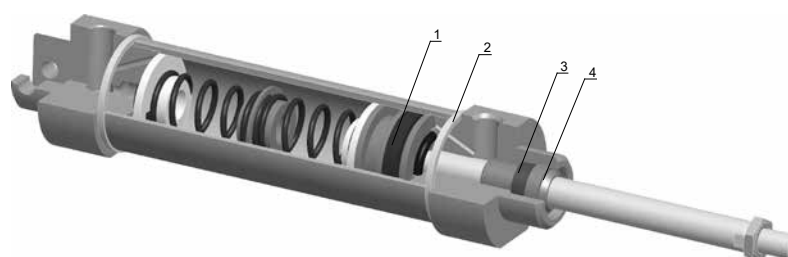

Position		1	2	3	4	Repair kit number
Spare part name		Piston gasket	Sealing washer	Piston rod gasket	Seal wiper ring	
Diameter D of the cylinder	D32	19.010E.04	19.010E.08	19.006D.05	19.0004.0004	10.009E.KN
<b>Number of pieces in the cylinder</b>						
with a single-sided piston rod		1	2	1	1	1

## ORDERING PROCEDURE

In your order, please specify: name of the spare part or repair kit, order number and the number of pieces, e.g.:

**Piston gasket for STD cylinder no. 19.010E.04 1 pc.**

## VARIETY 11.010

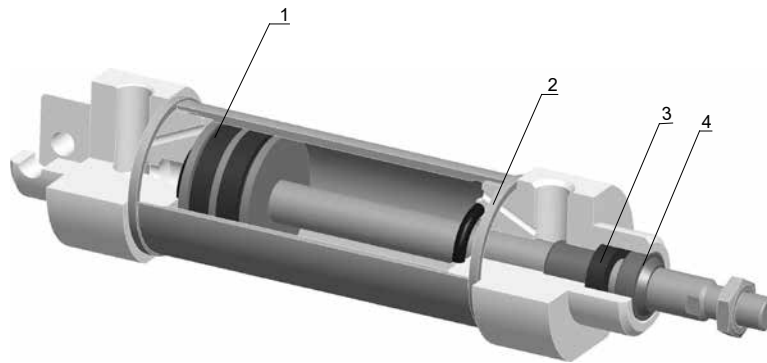

Position		1	2	3	4	Repair kit number
Spare part name		Piston gasket	Sealing washer	Piston rod gasket	Seal wiper ring	
Diameter D of the cylinder	D32	19.010E.04	19.010E.08	19.006D.05	19.0004.0004	<b>10.010E.KN</b>
<b>Number of pieces in the cylinder</b>						
with a single-sided piston rod		2	2	1	1	1

## VARIETY 11.019

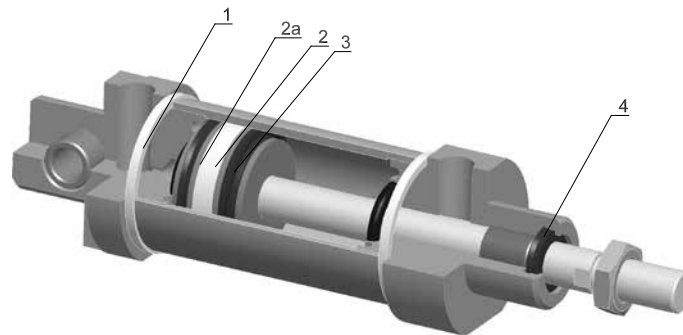

Position	10.019E series					11.019E series				
	1	2	3	4	Repair kit number	1	2a	4	Repair kit number	
Spare part name	Washer	Guide ring	Piston gasket	Piston rod gasket		Washer	Piston complete	Piston rod gasket		
Diameter D of the cylinder	D32	19.010E.08	13.013E.011	19.019E.04	19.018D.05	19.019E.KN	19.010E.08	13.050E.14. KAST	19.018D.05	<b>13.019E. KN11</b>
<b>Number of pieces in the cylinder</b>										
with a single-sided piston rod		2	1	2	1	1	2	1	1	1

## ORDERING PROCEDURE

In your order, please specify: name of the spare part or repair kit, order number and the number of pieces, e.g.:

**Guide ring for STD cylinder no. 13.013E.011 1 pc.**

## VARIETY 11.070 / 071

1

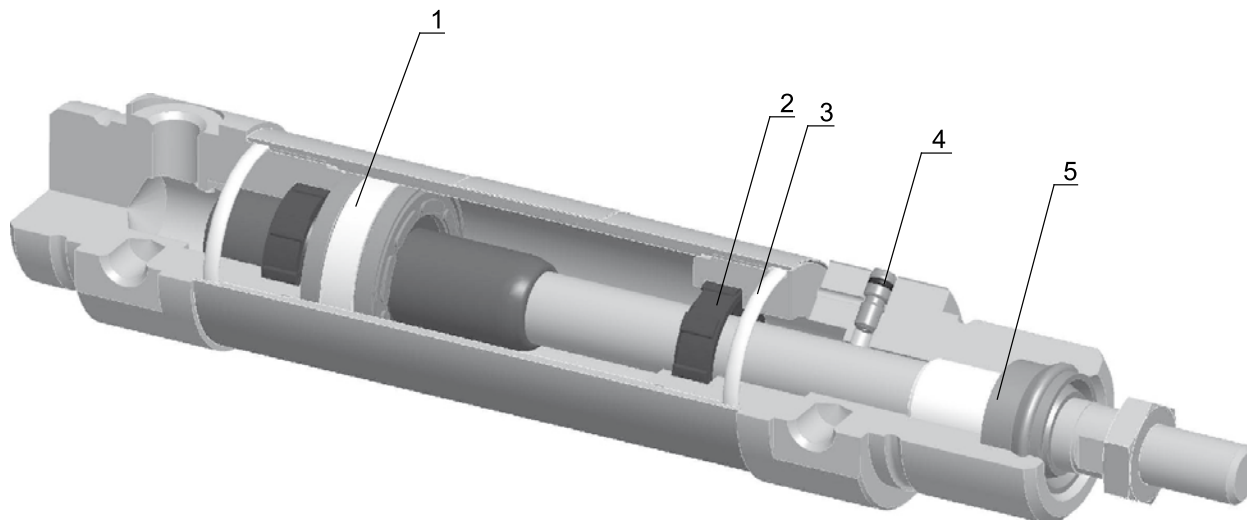

Position	1	2	3	4	5	Repair kit number		
Spare part name	Piston complete with magnet	Cushioning gasket	O-ring	O-ring	Piston rod gasket	Single-sided piston rod cylinder	Cylinder with a double-sided piston rod	
Diameter D of the cylinder	D32	13.050E.14.KAST	13.011E.09	19.0001.0063	19.0001.0033	13.011E.05	13.070E.KNKAST	13.071E.KNKAST
	D40	13.050F.14.KAST	13.011F.09	19.0001.0108		13.016F.05	13.070F.KNKAST	13.071F.KNKAST
	D50	13.050G.14.KAST	13.011H.09	19.0001.0110	19.0001.0033	13.016H.05	13.070G.KNKAST	13.071G.KNKAST
	D63	13.050H.14.KAST		19.0001.0109	-		13.070H.KNKAST	13.071H.KNKAST
	D80	13.050J.14.KAST	13.011K.09	19.0001.0081	-	13.016K.05	13.070J.KNKAST	13.071J.KNKAST
	D100	13.050K.14.KAST		19.0001.0019	-		13.070K.KNKAST	13.071K.KNKAST
<b>Number of pieces in the cylinder</b>								
with a single-sided piston rod	1	2	2	2	1	1	-	
with a double-sided piston rod	1	2	2	2	2	-	1	

## ORDERING PROCEDURE

In your order, please specify: name of the spare part or repair kit, order number and the number of pieces, e.g.:

**O-ring for SOK cylinder no. 19.0001.0063 1 pc.**

## VARIETY 11.015 / 016 / 017

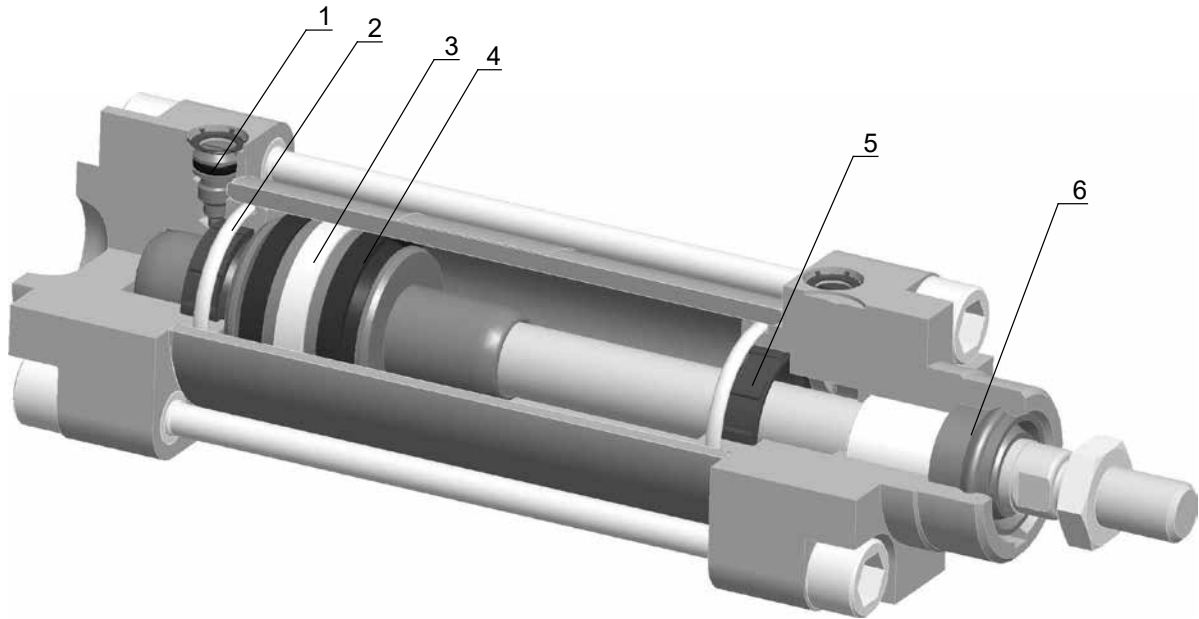

Position	1	2	3	4	5	6	7	Repair kit number			
Spare part name	O-ring for absorber gland	O-ring	Guide ring	Piston gasket	Cushioning gasket	Piston rod gasket	Spacer gasket*	Cylinder with a single-sided piston rod	Cylinder with a double-sided piston rod	TANDEM type cylinder	
Diameter D of the cylinder	D32	19.0001.0002	19.0001.0009	13.013E.01	13.011E.04	13.011E.09	13.011E.05	13.011E.15	13.016E.KN	13.017E.KN	13.015E.KN
	D40		19.0001.0011	13.013F.01	13.011F.04	13.011F.09	13.016F.05	13.016F.15	13.016F.KN	13.017F.KN	13.015F.KN
	D50		19.0001.0013	13.013G.01	13.011G.04	13.011H.09	13.016H.05	13.016H.15	13.016G.KN	13.017G.KN	13.015G.KN
	D63		19.0001.0015	13.013H.01	13.011H.04				13.016H.KN	13.017H.KN	13.015H.KN
	D80		19.0001.0017	13.013J.01	13.011J.04	13.011J.09	13.016K.05	13.016K.15	13.016J.KN	13.017J.KN	13.015J.KN
	D100	19.0001.0001	13.013K.01	13.011K.04	13.011K.09	13.016K.KN			13.017K.KN	13.015K.KN	
	D125	19.0001.0020	13.013L.01	13.011L.04		13.011L.05	13.016L.15	13.016L.KN	13.017L.KN	13.015L.KN	
	D160	19.0001.0021	13.013M.01	13.011M.04	13.011N.09	13.011N.05	13.011N.15	13.016M.KN	13.017M.KN	13.015M.KN	
	D200	19.0001.0035	13.013N.01	13.011N.04				13.016N.KN	13.017N.KN	13.015N.KN	
	D250	19.0001.0022	13.016P.01	13.016P.04	13.016P.09	13.016P.05	13.016P.15	13.016P.KN	13.017P.KN	13.015P.KN	
D320	19.0001.0072	16.016R.01	16.016R.04	13.016R.09	13.016R.05	13.016R.15	13.016R.KN	13.017R.KN	13.015R.KN		
<b>Number of pieces in the cylinder</b>											
with a single-sided piston rod	2	2	1	2	2	1	-	1	-	-	
with double-sided piston rod	2	2	1	2	2	2	-	-	1	-	
of the TANDEM type	2	4	2	4	2	1	2	-	-	1	

## ORDERING PROCEDURE

In your order, please specify: name of the spare part or repair kit, order number and the number of pieces, e.g.:

**O-ring for SSI cylinder No. 19.0001.0015 1 pc.**

\* Occurs in TANDEM type cylinders

## AMENDMENT 11.416

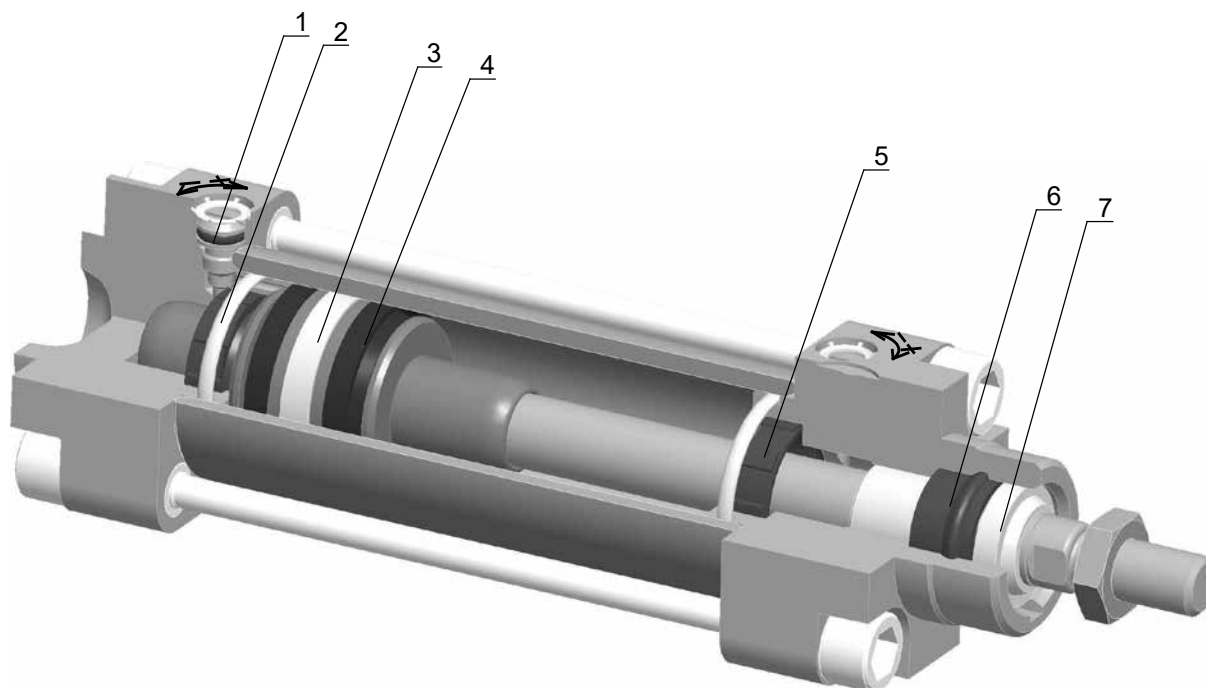

Position	1	2	3	4	5	6	7	Repair kit number	
Spare part name	O-ring for absorber gland	O-ring	Guide ring	Piston gasket	Cushioning gasket	Piston rod gasket	Seal wiper ring		
Diameter D of the cylinder	D32	19.0001.0002	19.0001.0009	13.013E.01	13.011E.04	13.011E.09	13.011E.05	13.016E.06	<b>13.416E.KN</b>
	D40		19.0001.0011	13.013F.01	13.011F.04	13.011F.09	13.016F.05	13.016F.06	<b>13.416F.KN</b>
	D50		19.0001.0013	13.013G.01	13.011G.04	13.011H.09	13.016H.05	13.016H.06	<b>13.416G.KN</b>
	D63		19.0001.0015	13.013H.01	13.011H.04		<b>13.416H.KN</b>		
	D80	19.0001.0017	13.013J.01	13.011J.04	13.011J.09	13.016K.05	13.016K.06	<b>13.416J.KN</b>	
	D100	19.0001.0001	13.013K.01	13.011K.04	13.011K.09		13.016L.06	<b>13.416K.KN</b>	
	D125	19.0001.0020	13.013L.01	13.011L.04		13.011L.05	13.016L.06	<b>13.416L.KN</b>	
	D160	19.0001.0021	13.013M.01	13.011M.04	13.011N.09	13.016N.06	<b>13.416M.KN</b>		
	D200	19.0001.0035	13.013N.01	13.011N.04		13.016N.06	<b>13.416N.KN</b>		
	D250	19.0001.0022	13.016P.01	13.016P.04		13.016P.09	13.016P.05	13.016P.06	<b>13.416P.KN</b>
D320	19.0001.0072	16.016R.01	16.016R.04	13.016R.09		13.016R.05	13.016R.06	<b>13.416R.KN</b>	
<b>Number of pieces in the cylinder</b>									
with a single-sided piston rod	2	2	1	2	2	1	1	1	

## ORDERING PROCEDURE

In your order, please specify: name of the spare part or repair kit, order number and the number of pieces, e.g.:

**Piston rod gasket for SSI cylinder No. 13.011E.05 1 pc.**

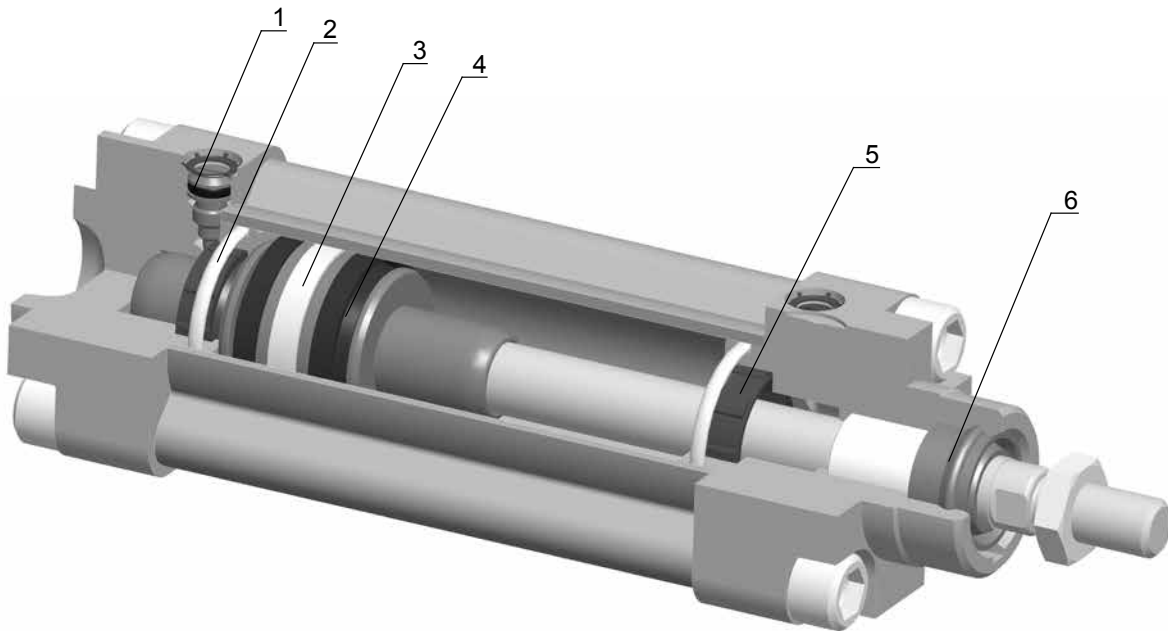

Position		1	2	3	4	5	6	Repair kit number	
Spare part name		O-ring for absorber gland	O-ring	Guide ring	Piston gasket	Cushioning gasket	Piston rod gasket	Single-sided piston rod cylinder	Cylinder with a double-sided piston rod
Diameter D of the cylinder	D32	19.0001.0002	19.0001.0009	13.013E.01	13.011E.04	13.011E.09	13.011E.05	13.016E.KN	13.017E.KN
	D40		19.0001.0011	13.013F.01	13.011F.04	13.011F.09	13.016F.05	13.016F.KN	13.017F.KN
	D50		19.0001.0013	13.013G.01	13.011G.04	13.011H.09	13.016H.05	13.016G.KN	13.017G.KN
	D63		19.0001.0015	13.013H.01	13.011H.04			13.016H.KN	13.017H.KN
	D80		19.0001.0017	13.013J.01	13.011J.04	13.011J.09	13.016K.05	13.016J.KN	13.017J.KN
	D100	19.0001.0003	19.0001.0001	13.013K.01	13.011K.04	13.011K.09		13.016K.KN	13.017K.KN
<b>Number of pieces in the cylinder</b>									
with a single-sided piston rod		2	2	1	2	2	1	1	-
with a double-sided piston rod		2	2	1	2	2	2	-	1

## ORDERING PROCEDURE

In your order, please specify: name of the spare part or repair kit, order number and the number of pieces, e.g.:

**O-ring for STK cylinder no. 19.0001.0009 1 pc.**

## VARIETY 11.116 / 117

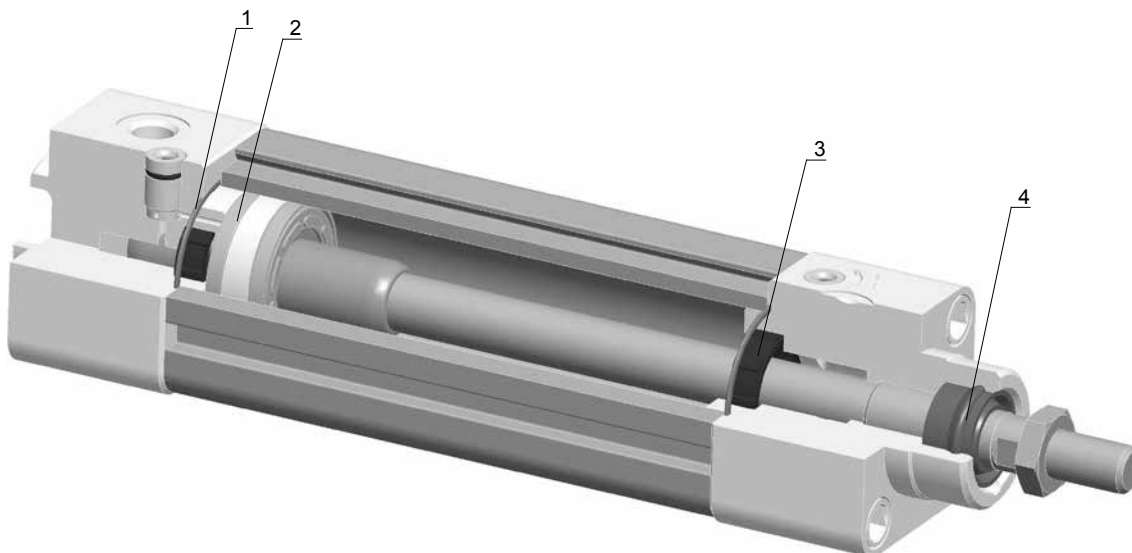

Position	1	2	3	4	Repair kit number		
Spare part name	O-ring	Piston complete with magnet	Cushioning gasket	Piston rod gasket	Cylinder with a single-sided piston rod	Cylinder with a double-sided piston rod	
Diameter D of the cylinder	D32	19.0001.0113	13.050E.14.KAST	13.011E.09	13.011E.05	13.116E.KNKAST	13.117E.KNKAST
	D40	19.0001.0076	13.050F.14.KAST	13.011F.09	13.016F.05	13.116F.KNKAST	13.117F.KNKAST
	D50	19.0001.0089	13.050G.14.KAST	13.011H.09	13.016H.05	13.116G.KNKAST	13.117G.KNKAST
	D63	19.0001.0114	13.050H.14.KAST			13.116H.KNKAST	13.117H.KNKAST
	D80	19.0001.0078	13.050J.14.KAST	13.011K.09	13.016K.05	13.116J.KNKAST	13.117J.KNKAST
	D100	19.0001.0115	13.050K.14.KAST			13.116K.KNKAST	13.117K.KNKAST
<b>Number of pieces in the cylinder</b>							
with a single-sided piston rod	2	1	2	1	1	-	
with a double-sided piston rod	2	1	2	2	-	1	

## ORDERING PROCEDURE

In your order, please specify: name of the spare part or repair kit, order number and the number of pieces, e.g.:

**Piston rod gasket for STE cylinder no. 13.011E.05 1 pc.**

## VARIETY 11.001 / 002 / 003

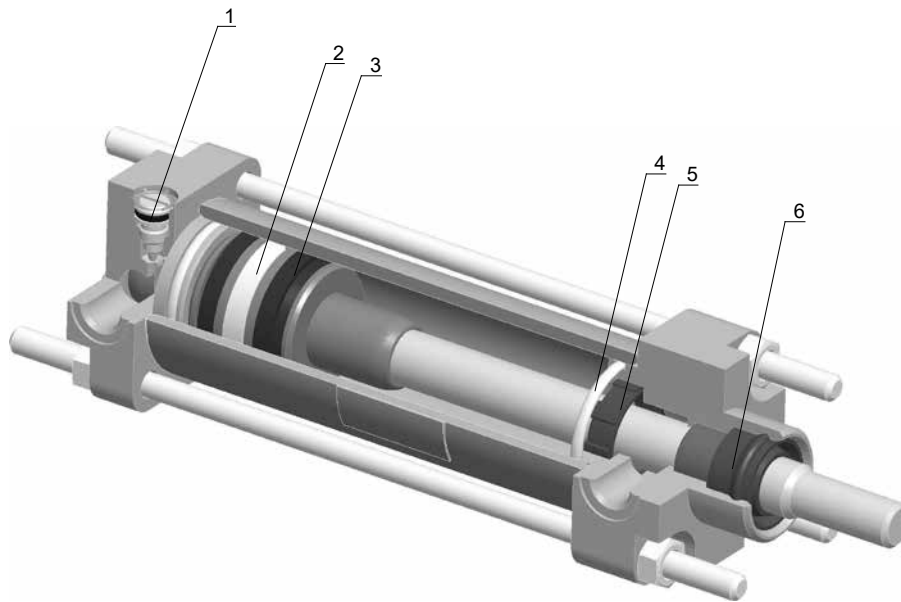

Position	1	2	3	4	5	6	7	Repair kit number			
Spare part name	O-ring for absorber gland	Guide ring	Piston gasket	O-ring	Cushioning gasket	Piston rod gasket	Spacer gasket*	Cylinder with a single-sided piston rod	Cylinder with a double-sided piston rod	TANDEM type cylinder	
Diameter D of the cylinder	D32	19.0001.0002	13.013E.01	13.011E.04	19.0001.0009	13.011E.09	13.011E.05	13.011E.15	<b>13.001E.KN</b>	<b>13.002E.KN</b>	<b>13.003E.KN</b>
	D40		13.013F.01	13.011F.04	19.0001.0011	13.011F.09	13.001G.05	13.001G.15	<b>13.001F.KN</b>	<b>13.002F.KN</b>	<b>13.003F.KN</b>
	D50		13.013G.01	13.011G.04	19.0001.0013	13.011H.09	13.001G.05	13.001G.15	<b>13.001G.KN</b>	<b>13.002G.KN</b>	<b>13.003G.KN</b>
	D63	19.0001.0003	13.013H.01	13.011H.04	19.0001.0015	13.011H.09	13.001J.05	13.001J.15	<b>13.001H.KN</b>	<b>13.002H.KN</b>	<b>13.003H.KN</b>
	D80		13.013J.01	13.011J.04	19.0001.0017	13.011J.09	13.001J.05	13.001J.15	<b>13.001J.KN</b>	<b>13.002J.KN</b>	<b>13.003J.KN</b>
	D100		13.013K.01	13.011K.04	19.0001.0001	13.011K.09	13.001L.05	13.001L.05	<b>13.001K.KN</b>	<b>13.002K.KN</b>	<b>13.003K.KN</b>
	D125		13.013L.01	13.011L.04	19.0001.0020	13.011K.09	13.001L.05	13.001L.05	<b>13.001L.KN</b>	<b>13.002L.KN</b>	<b>13.003L.KN</b>
	D160		13.013M.01	13.011M.04	19.0001.0021	13.011N.09	13.001N.05	13.011N.05	<b>13.001M.KN</b>	<b>13.002M.KN</b>	<b>13.003M.KN</b>
D200	13.013N.01	13.011N.04	19.0001.0035	13.011N.09	13.001N.05	13.011N.05	<b>13.001N.KN</b>	<b>13.002N.KN</b>	<b>13.003N.KN</b>		
<b>Number of pieces in the cylinder</b>											
with a single-sided piston rod	2	1	2	2	2	1	-	1	-	-	
with a double-sided piston rod of the TANDEM type	2	1	2	2	2	2	-	-	1	-	
	2	2	4	4	2	1	2	-	-	1	

## ORDERING PROCEDURE

In your order, please specify: name of the spare part or repair kit, order number and the number of pieces, e.g.:

**O-ring for SCN cylinder no. 19.0001.0015 1 pc.**

\* Occurs in TANDEM type cylinders



## VARIETY 11.030 / 130

1

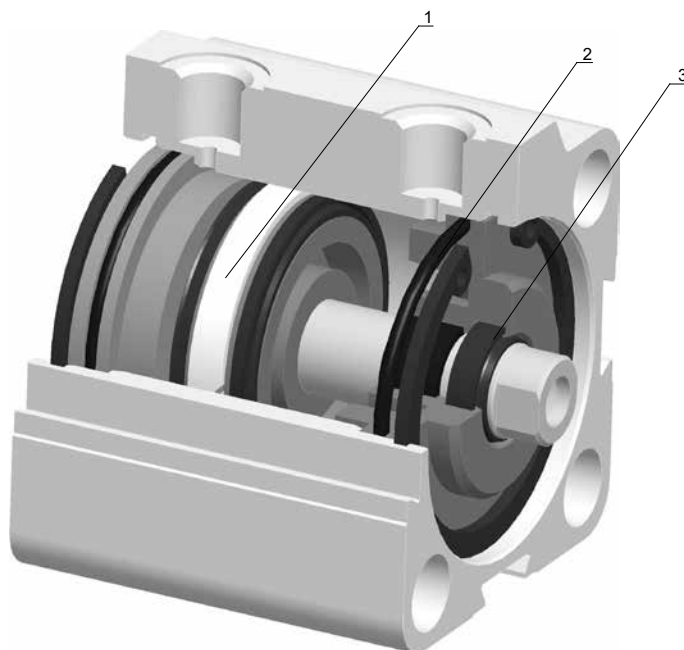

Position		1	2	3	Repair kit number	
Spare part name		Piston complete	O-ring	Piston rod gasket		
11.030X series	Diameter D of the cylinder	D16	13.030B.14	-	13.030B.05	13.030B.KNKA
		D20	13.030C.14	-	19.018D.05	13.030C.KNKA
		D25	13.030D.14	19.0001.0054		13.030D.KNKA
		D32	13.050E.14	19.0001.0063	13.050F.05	13.130E.KNKA
D40		13.050F.14	19.0001.0058	13.130F.KNKA		
11.130X series		D50	13.050G.14	19.0001.0014	13.050H.05	13.130G.KNKA
		D63	13.050H.14	19.0001.0090		13.130H.KNKA
		D80	13.050J.14	19.0001.0081		13.0150J.05
	D100	13.050K.14	19.0001.0019	13.050K.05	13.130K.KNKA	
	<b>Number of pieces in the cylinder</b>					
with a single-sided piston rod	D16–D25	-	2	1	1	
	D32–D100	1	2	1	-	

## ORDERING PROCEDURE

In your order, please specify: name of the spare part or repair kit, order number and the number of pieces, e.g.:

**O-ring for SDK cylinder no. 19.0001.0015 1 pc.**

## VARIETY 11.031 / 131

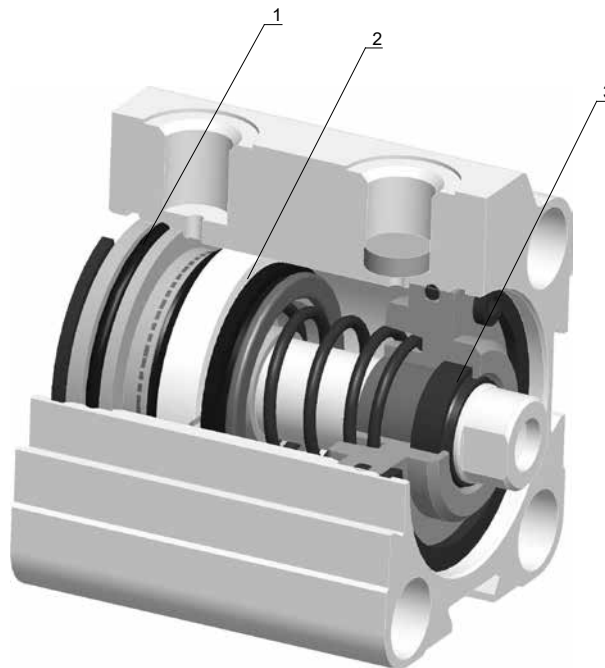

Position		1	2	3	Repair kit number	
Spare part name		O-ring	Piston complete	Piston rod gasket		
11.031X series	Diameter D of the cylinder	D16	-	13.030B.14	13.030B.05	<b>13.030B.KN</b>
		D20	-	13.030C.14	19.018D.05	<b>13.030C.KN</b>
		D25	19.0001.0054	13.030D.14	19.018D.05	<b>13.030D.KN</b>
		D32	19.0001.0063	13.050E.14	13.050F.05	<b>13.131E.KN</b>
11.131X series		D40	19.0001.0058	13.050F.14	13.050F.05	<b>13.131F.KN</b>
		D50	19.0001.0014	13.050G.14	13.050H.05	<b>13.131G.KN</b>
		D63	19.0001.0090	13.050H.14	13.050H.05	<b>13.131H.KN</b>
		D80	19.0001.0081	13.050J.14	13.0150J.05	<b>13.131J.KN</b>
	D100	19.0001.0019	13.050K.14	13.050K.05	<b>13.131K.KN</b>	
<b>Number of pieces in the cylinder</b>						
with a single-sided piston rod	D16–D25	-	1	1	1	
	D32–D100	2	1	1	-	

## ORDERING PROCEDURE

In your order, please specify: name of the spare part or repair kit, order number and the number of pieces, e.g.:

**O-ring for SDK cylinder no. 19.0001.0015 1 pc.**

# REPAIR KITS

for SKP cylinders



## VARIETY 11.050 / 051 / 052 / 053

1

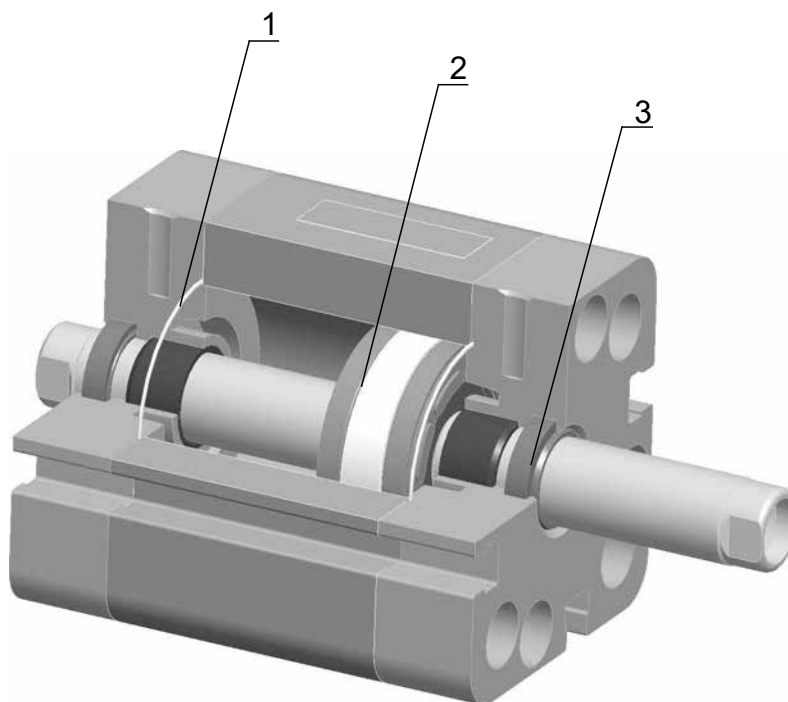

Position		1	2	3	Repair kit number	
Spare part name		O-ring	Piston complete	Piston rod gasket	Cylinder with a single-sided piston rod	Cylinder with a double-sided piston rod
Diameter D of the cylinder	D32	19.0001.0075	13.050E.14	13.050F.05	13.050E.KNKAST	13.051E.KNKAST
	D40	19.0001.0076	13.050F.14		13.050F.KNKAST	13.051F.KNKAST
	D50	19.0001.0077	13.050G.14	13.050H.05	13.050G.KNKAST	13.051G.KNKAST
	D63	19.0001.0074	13.050H.14		13.050H.KNKAST	13.051H.KNKAST
	D80	19.0001.0078	13.050J.14	13.050J.05	13.050J.KNKAST	13.051J.KNKAST
	D100	19.0001.0079	13.050K.14	13.050K.05	13.050K.KNKAST	13.051K.KNKAST
<b>Number of pieces in the cylinder</b>						
with a single-sided piston rod		2	1	1	1	-
with a double-sided piston rod		2	1	2	-	1

## ORDERING PROCEDURE

In your order, please specify: name of the spare part or repair kit, order number and the number of pieces, e.g.:

**Piston rod gasket for SKP cylinder no. 13.050F.05 1 pc.**

## VARIETY 18.0382 / 0383



Position		1	2	Repair kit number
Spare part name		Piston gasket	Guide ring	
Diameter D of the cylinder	D25	19.018D.04	13.013D.01	18.0382.KN
	D32	19.018E.04	13.013E.01	18.0383.KN
<b>Number of pieces in the cylinder</b>				
with a single-sided piston rod		1	1	1

## ORDERING PROCEDURE

Please state the following in your order: name of the spare part or repair kit, order number and the number of pieces e.g.:

**Piston gasket for SCP cylinder no. 19.018D.04 1 pc.**

## VARIETY 11.081/ 082

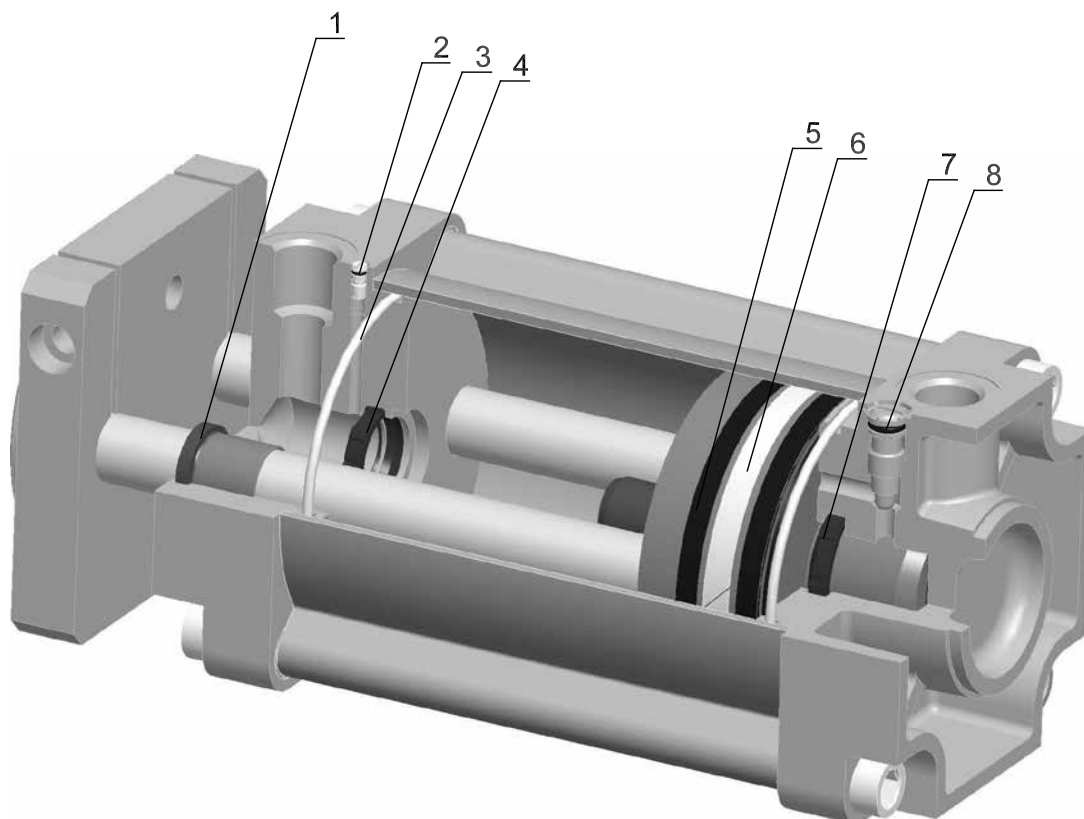

Position	1	2	3	4	5	6	7	8	Repair kit number	
Spare part name	Piston rod gasket	O-Ring for absorber gland I	O-ring	Cushioning gasket I	Piston gasket	Guide ring	Cushioning gasket II	O-ring for absorber gland II		
Diameter D of the cylinder	D32	13.081E.05	19.0001.0033	19.0001.0009	13.081F.09	13.030E.04	13.130E.01	13.011E.09	19.0001.0048	<b>13.081E.KN</b>
	D40	13.081F.05	19.0001.0033	19.0001.0011		13.030F.04	13.130F.01	13.011F.09	19.0001.0048	<b>13.081F.KN</b>
	D50	13.081EG.05	19.0001.0033	19.0001.0013	13.081G.09	13.030G.04	13.130G.01	13.011H.09	19.0001.0048	<b>13.081G.KN</b>
	D63	13.081H.05	19.0001.0033	19.0001.0015	13.081H.09	13.030H.04	13.130H.01		19.0001.0048	<b>13.081H.KN</b>
	D80	13.081K.05	19.0001.0033	19.0001.0017	13.011E.09	13.030J.04	13.130J.01	13.011K.09	19.0001.0048	<b>13.081J.KN</b>
	D100	13.081K.05	19.0001.0033	19.0001.0001	13.011F.09	13.030K.04	13.130K.01		19.0001.0070	<b>13.081K.KN</b>
<b>Number of pieces in the cylinder</b>										
with a single-sided piston rod	1	1	2	1	2	1	1	1	1	

## ORDERING PROCEDURE

In your order, please specify: name of the spare part or repair kit, order number and the number of pieces, e.g.:

**Piston gasket for SPT cylinder no. 13.030E.04 1 pc.**

## VARIETY 11.035 / 036

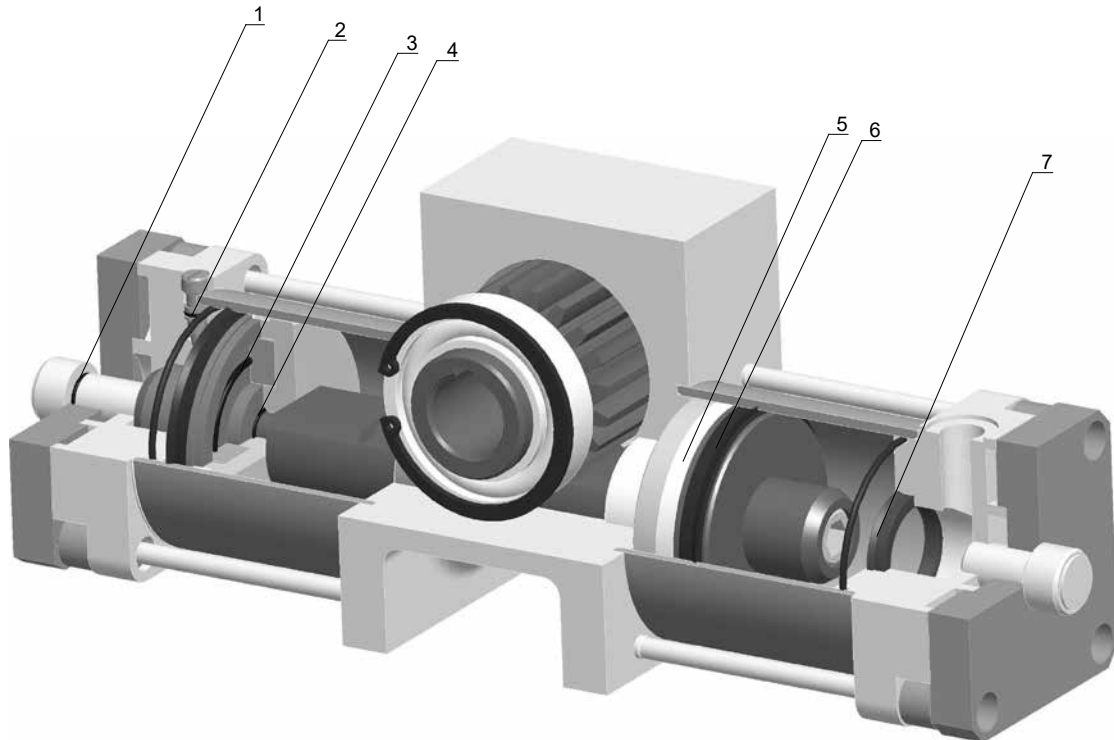

Position	1	2	3	4	5	6	7	Repair kit number	
Spare part name	O-ring	O-ring for absorber gland	O-ring	O-ring	Guide ring	Piston gasket	Cushioning gasket		
Diameter D of the cylinder	D32	19.0001.0004	19.0001.0048	19.0001.0009	19.0001.0006	13.013E.01	13.011E.04	13.011E.09	<b>13.035E.KN</b>
	D40	19.0001.0112		19.0001.0011	19.0001.0007	13.013F.01	13.011F.04	13.011F.09	<b>13.035F.KN</b>
	D50	19.0001.0012	19.0001.0070	19.0001.0013	19.0001.0116	13.013G.01	13.011G.04	13.011H.09	<b>13.035G.KN</b>
	D63	19.0001.0005		19.0001.0073	19.0001.0008	13.013H.01	13.011H.04		<b>13.035H.KN</b>
	D80	19.0001.0005	19.0001.0017	19.0001.0009	13.013J.01	13.011J.04	13.011J.09	<b>13.035J.KN</b>	
	D100	19.0001.0006	19.0001.0001		13.013K.01	13.011K.04	13.011K.09	<b>13.035K.KN</b>	
	D125	19.0001.0007	19.0001.0020	19.0001.0011	13.013L.01	13.011L.04	13.011K.09	<b>13.035L.KN</b>	
	<b>Number of pieces in the cylinder</b>								
with a single-sided piston rod	2	2	2	2	2	2	2	1	

## ORDERING PROCEDURE

In your order, please specify: name of the spare part or repair kit, order number and the number of pieces, e.g.:

**Piston gasket for SWH cylinder no. 13.011E.04 1 pc.**

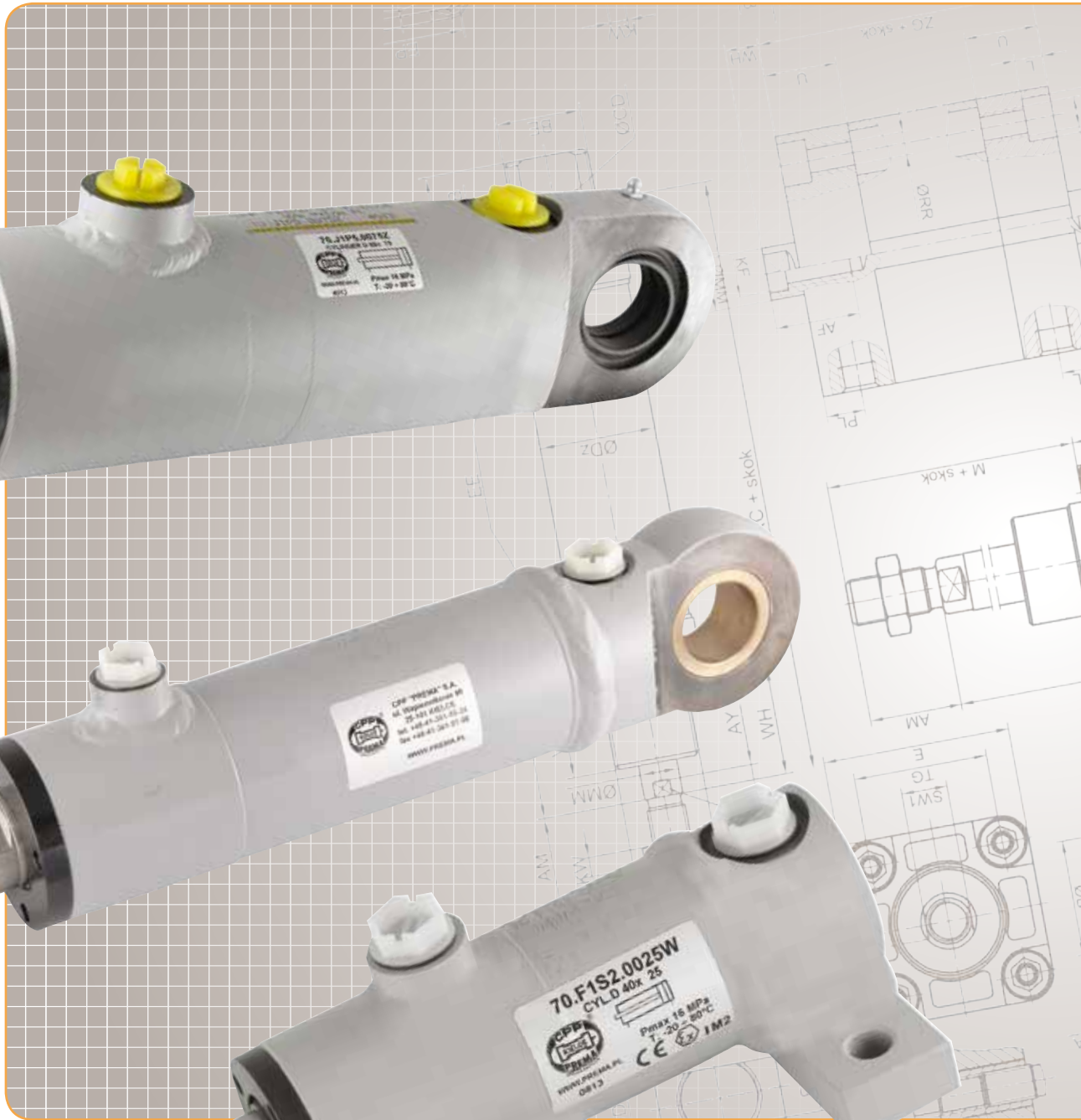
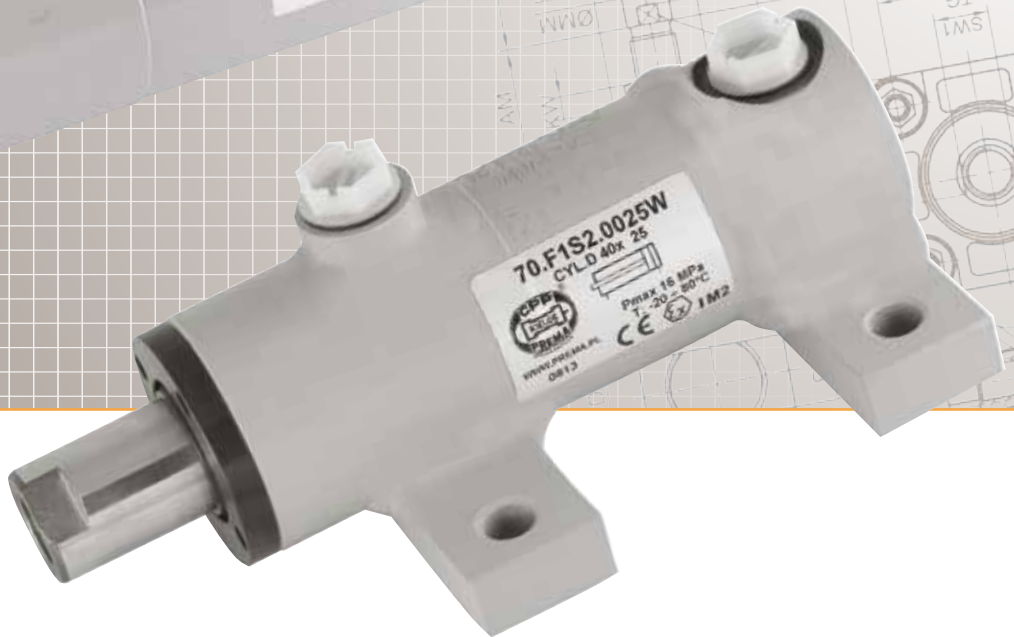



# HYDRAULIC CYLINDERS



## Hydraulic cylinders

- 2.01** Hydraulic piston cylinders D25–D160
  - 2.01.01** Hydraulic piston cylinders
  - 2.01.02** Additional equipment
- 2.02** Hydraulic plunger cylinders D25–D80
- 2.03** Accessories for hydraulic actuators



#### TECHNICAL SPECIFICATIONS

<b>Nominal operating pressure:</b>	16 MPa
<b>Operating temperature range:</b>	from 30°C to +80°C
<b>Max. speed, Piston rod:</b>	$v_{max} = 0.5 \text{ m/s}$
<b>Medium:</b>	<ul style="list-style-type: none"> <li>- mineral hydraulic oils with viscosities from 10 to 450 cSt</li> <li>- aqueous solutions of HFC polymers with a 35% min. water content</li> <li>- HFA type oil-water emulsions with a 20% max. content of combustible parts</li> <li>- HFB type water-oil emulsions with a 60% max. content of combustible parts</li> </ul>
<b>Cylinder protection:</b>	For series 70: External surfaces of the cylinder body are protected against corrosion. "Corrosion category" according to EN ISO 12944 - C5-I Lifetime Medium - M (5 to 15 years) Surface preparation degree acc. to PN- EN ISO 8501-1 - Sa 2 1/2 For series 71: Painted with anti-corrosion paint
<b>Materials:</b>	
<b>Body, head</b>	- structural carbon steel
<b>Piston rod</b>	- structural carbon steel, acid-resistant steel, chrome-plated surfaces
<b>Seals</b>	- plastic



#### USE

Piston hydraulic cylinders are devices used in hydraulic systems as actuation elements. They are used in many branches of the industry, including agricultural, construction, mining and timber machinery, road and rail transport and various types of specialist equipment. The cylinders are made of the highest quality construction materials. We use in them the most modern seals of the world's leading sealing manufacturers. Furthermore, all the cylinders manufactured by us have anti-corrosion coatings and undergo detailed quality control, including leakage pressure tests. This guarantees their high quality and durability in the most difficult operating conditions.

**CYLINDERS OF GROUP 70 DIMENSIONS ARE APPROVED FOR USE IN AREAS WITH RISK.**

#### THEORETICAL PUSHING AND PULLING FORCE AT NOMINAL PRESSURE $P_N = 16 \text{ MPa}$

		Theoretical force [daN] [kG]									
cylinder diameter D		D25	D32	D40	D50	D63	D80	D100	D125	D140	D160
Pushing force	70	785	1287	2011	3140	4988	8040	12560	19630	-	32150
	71									24618	
Pulling force	70	464	784	1255	1860	2977	4900	7560	11590	-	19600
	71	377	680	1403	2155	3360	5500	7560	13470	16580	21980

#### Hydraulic cylinders:

- two-way operation
- with a single-sided piston rod
- with a double-sided piston rod (version S2)
- with "Z" type male thread
- with "W" type female thread
- with "M" type mixed piston rod ends

#### Mount type:

- F3 - with a round head flange
- F4 - with a round bottom flange
- P3 - with a bottom eye with a self-aligning bearing
- P5 - with a bottom eye with an articulated bearing
- S2 - with a transverse bracket mounting
- T4 - with intermediate journals (with Central Trunnion)

# HYDRAULIC CYLINDERS

piston D25 – D160

Dimension group 70; 71



## P3 MOUNTING

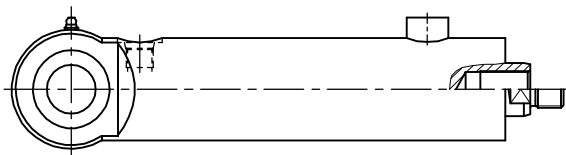

## P5 MOUNTING

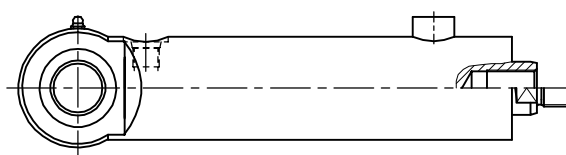

## F3 MOUNTING

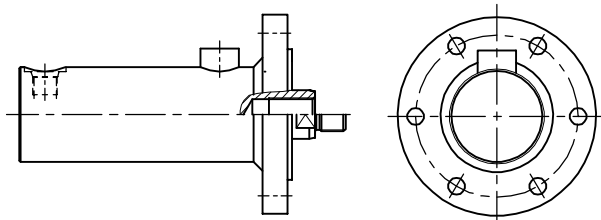

## F4 MOUNTING

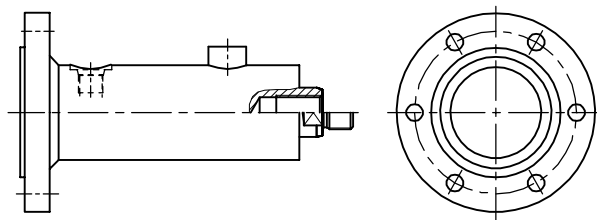

## S2 MOUNTING

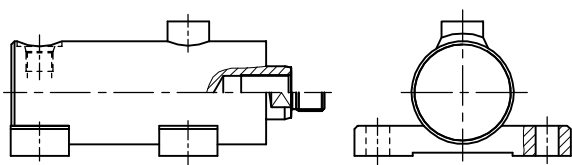

## T4 MOUNTING

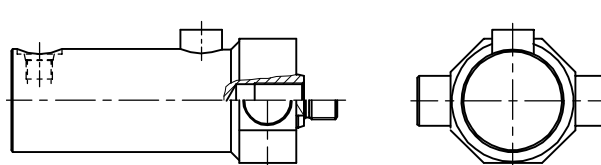

## S2 MOUNTING WITH A DOUBLE-SIDED PISTON ROD

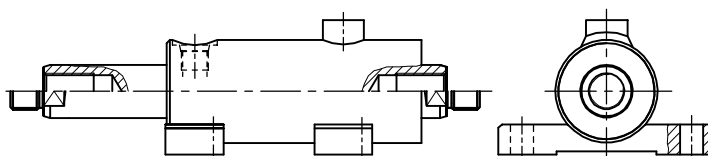

## ORDER NUMBER CONSTRUCTION

for cylinders with brakes

**70 . H 1 P 5 . 0500 Z K G**

**Code of the dimensional group (type) of the cylinder**  
**70** - value of the piston surface area ratio  $\phi=1.6$   
**71** - value of the piston surface area ratio  $\phi=1.4$

**Cylinder diameter code**  
**D** - 25 mm  
**E** - 32 mm  
**F** - 40 mm  
**G** - 50 mm  
**H** - 63 mm  
**J** - 80 mm  
**K** - 100 mm  
**L** - 125 mm  
**M** - 160 mm

**Cylinder version code**  
**1** - with single -sided piston rod - STANDARD version  
**2\*** -with double-sided piston rod - STANDARD version  
**3** - with single-sided piston rod - for operating at high temperatures.  
**4\*** -with double-sided piston rod - for operating at high temperatures.

**Mounting type code**  
**F3** - round head flange  
**F4** - round bottom flange  
**P3** - bottom eye with a self-aligning bearing  
**P5** - bottom eye with an articulated bearing  
**S2** - transverse brackets  
**T4** - intermediate journals (Central Trunnion)

**Stroke [mm]**  
 stroke e.g. 0200=200 mm

**Piston rod tip version code**  
**Z** -male thread  
**W** -female thread  
**M\*** - mixed piston rod versions: one with a male thread, the other with a female thread

**Code for piston rod material**  
**without designation** - structural steel  
**K** - acid-resistant steel  
**N** - stainless steel  
**H** - induction hardened

**Braking system code (for version 70)**  
**without designation** - without braking  
**D** - bottom-side braking  
**G** - head-side braking  
**B** - both sides braking

## ORDERING PROCEDURE

In your order please specify: name, nominal diameter, actuator stroke, mounting type code, piston rod end code, order number and the number of pieces, e.g.:

**Hydraulic cylinder D63 x 500 with F4 mounting round bottom flange, male thread on a piston rod, no. 70.H1F4.0500ZK 1 pc.**

\*concerns the S2 mounting

# HYDRAULIC CYLINDERS

piston with inductive sensors

Dimension group 70; 71



## ALLOWABLE POSITIONS OF INDUCTIVE SENSORS

Cylinder diameter D	Mounting type																	
	F3			F4			P3			P5			S2			T4		
	X	Y	Z	X	Y	Z	X	Y	Z	X	Y	Z	X	Y	Z	X	Y	Z
32	X	Y	Z	X	Y	Z	X	Y	Z	X	Y	Z	X	Y	Z	X	Y	Z
40	X	Y	Z	X	Y	Z	X	Y	Z	X	Y	Z	X	Y	Z	X	Y	Z
50	X	Y	Z	X	Y	Z	X	Y	Z	X	Y	Z	X	Y	Z	X	Y	Z
63	X	Y	Z	X	Y	Z	X	Y	Z	X	Y	Z	X	Y	Z	X	Y	Z
80	X	Y	Z	X	Y	Z	X	Y	Z	X	Y	Z	X	Y	Z	X	Y	Z
100	X	Y	Z	X	Y	Z	X	Y	Z	X	Y	Z	X	Y	Z	X	Y	Z
125	X	Y	Z	X	Y	Z	X	Y	Z	X	Y	Z	X	Y	Z	X	Y	Z
160	X	Y	Z	X	Y	Z	X	Y	Z	X	Y	Z	X	Y	Z	X	Y	Z

- possible position of the sensors

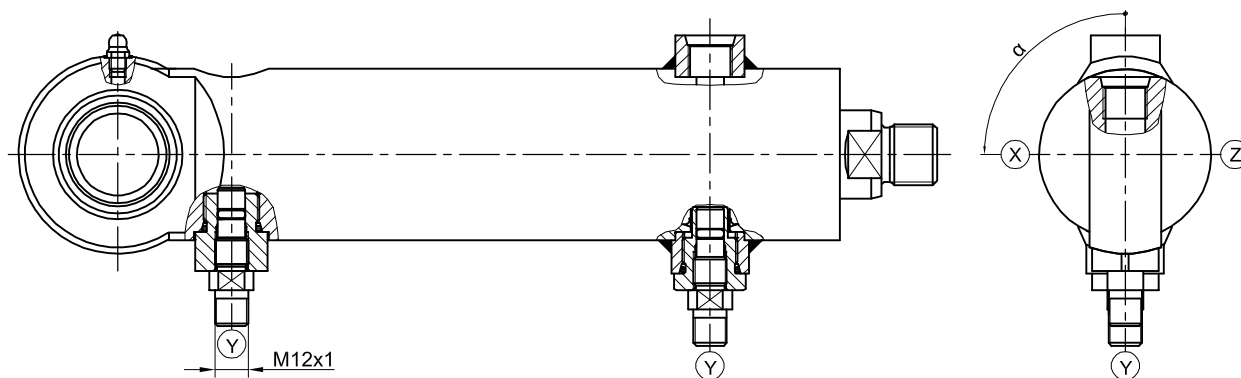

NOTE: when ordering a hydraulic cylinder with an inductive sensor, the cylinder is sold complete with the sensor.

### ORDER NUMBER CONSTRUCTION for cylinders with inductive sensors

**70 . H 1 P3 . 0200 Z K X**

**Code of the dimensional group (type) of the cylinder**

70 - value of the piston surface area ratio  $\phi=1.6$   
71 - value of the piston surface area ratio  $\phi=1.4$

**Cylinder diameter code**

E - 32 mm  
F - 40 mm  
G - 50 mm  
H - 63 mm  
J - 80 mm  
K - 100 mm  
L - 125 mm  
M - 160 mm

**Cylinder version code**

1 - with single-sided piston rod - STANDARD version  
2\* - with double-sided piston rod - STANDARD version  
3 - with single-sided piston rod - for operating at high temperatures.  
4\* - with double-sided piston rod - for operating at high temperatures.

**Mounting type code**

F3 - round head flange  
F4 - round bottom flange  
P3 - bottom eye with a self-aligning bearing  
P5 - bottom eye with an articulated bearing  
S2 - transverse brackets  
T4 - intermediate journals (Central Trunnion)

**Stroke [mm]**

stroke e.g. 0200=200 mm

**Piston rod tip version code**

Z - male thread  
W - female thread  
M\* - mixed piston rod versions: one with male thread, the other with female thread

**Code for piston rod material**

**without designation** - structural steel  
K - acid-resistant steel  
N - stainless steel  
H - induction hardened

**Position code for inductive sensors in "B" double-braking cylinders**

X -  $\alpha = 90^\circ$   
Y -  $\alpha = 180^\circ$   
Z -  $\alpha = 270^\circ$

### ORDERING PROCEDURE

In your order please specify: name, nominal diameter, actuator stroke, mounting type code, piston rod end code, position of inductive sensor, order number and number of pieces, e.g.:

**Hydraulic cylinder D63 x 500 with F4 mounting round bottom flange, male thread on a piston rod, sensor position  $\alpha=90^\circ$  No. 70.H1F4.0500ZKX 1 pc.**

\*concerns the S2 mounting

### P3, P5 MOUNTING

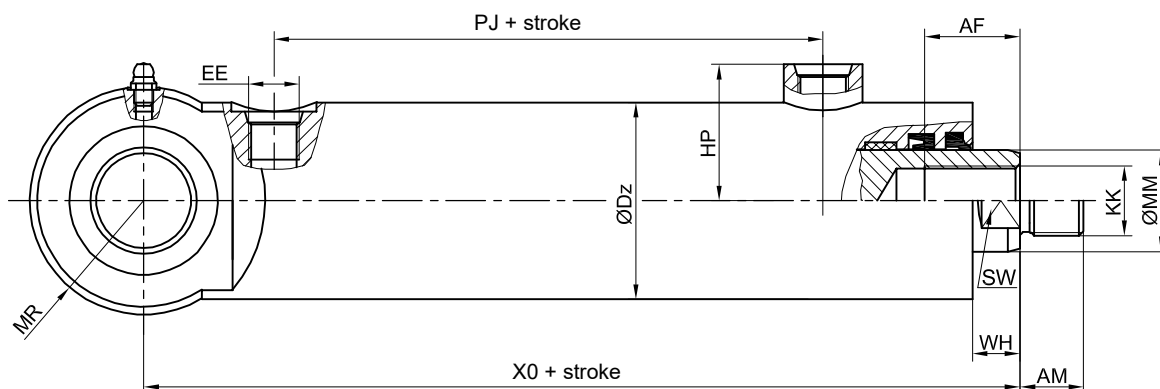

P3 mounting

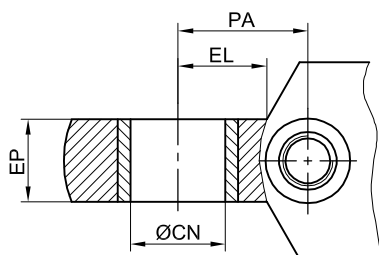

P5 mounting

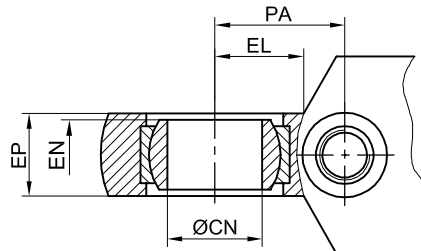

DIMENSIONS [mm]											
CYLINDER DIAMETER D	25	32	40	50	63	80	100	125	140	160	
ØMM	70	16	20	25	32	40	50	63	80	-	100
	71	18	22	22	28	36	45	56	70	80	90
AM	14	16	18	20	22	30	36	45	50	56	
AF	16	22	22	30	36	45	50	63	75	85	
ØCN	16	20	25	30	35	40	50	60	70	80	
ØDz	35	40	52	62	75	95	120	145	170	190	
EE	M14×1.5	M14×1.5	M16×1.5	M16×1.5	M22×1.5	M27×2	M33×2	M33×2	M33×2	M33×2	
EL	17	22	26	28	36	45	56	70	80	90	
EN	14	16	20	22	25	28	35	44	49	55	
EP	14	20	24	26	31	32	40	55	60	65	
HP	31	35	37	43	51	62	75	87.5	98	110	
KK	M12×1.5	M16×1.5	M16×1.5	M22×1.5	M27×2	M33×2	M42×2	M48×2	M56×2	M64×2	
MR	22	25	30	36	40	47.5	60	72.5	84	95	
PA	28	33	38	41	53	65	80	90	110	122	
PJ	56	61	64	73	85	105	124	138	155	154	
SW	13	16	21	27	36	46	55	70	70	87	
WH	12	12	10	15	15	18	20	23	26	36	
XO	128	149	160	176	212	255	300	338	391	411	

### F3 MOUNTING

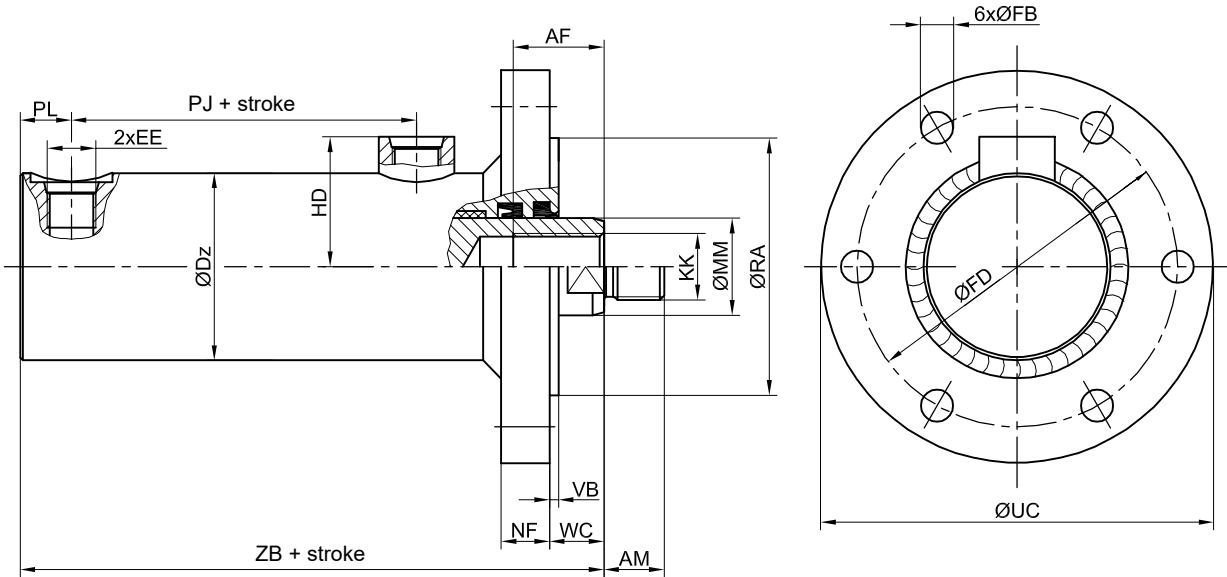

DIMENSIONS [mm]											
CYLINDER DIAMETER D	25	32	40	50	63	80	100	125	140	160	
ØMM	70	16	20	25	32	40	50	63	80	-	100
	71	18	22	22	28	36	45	56	70	80	90
AM	14	16	18	20	22	30	36	45	50	56	
AF	16	22	22	30	36	45	50	63	75	85	
ØDz	35	40	52	62	75	95	120	145	170	190	
EE	M14x1.5	M14x1.5	M16x1.5	M16x1.5	M22x1.5	M27x2	M33x2	M33x2	M33x2	M33x2	
ØFB	7	9	9	11	13.5	17	22	22	26	26	
ØFD	66	85	90	106	130	175	200	230	240	280	
HD	31	35	37	43	50	62	75	87.5	98	110	
KK	M12x1.5	M16x1.5	M16x1.5	M22x1.5	M27x2	M33x2	M42x2	M48x2	M56x2	M64x2	
NF	10	12	14	16	18	19	25	30	30	35	
PJ	58	61	64	73	85	105	124	138	155	154	
PL	13	13	16	17	21	20	27	28	35	32	
ØRA	50	60	65	85	100	135	150	180	185	240	
ØUC	80	105	110	130	160	210	240	280	288	340	
VB	2	2	3	3	3	3	5	4	5	5	
WC	14	14	12	18	20	31	30	32	20	50	
ZB	115	129	138	152	180	210	247	271	316	321	



### F4 MOUNTING

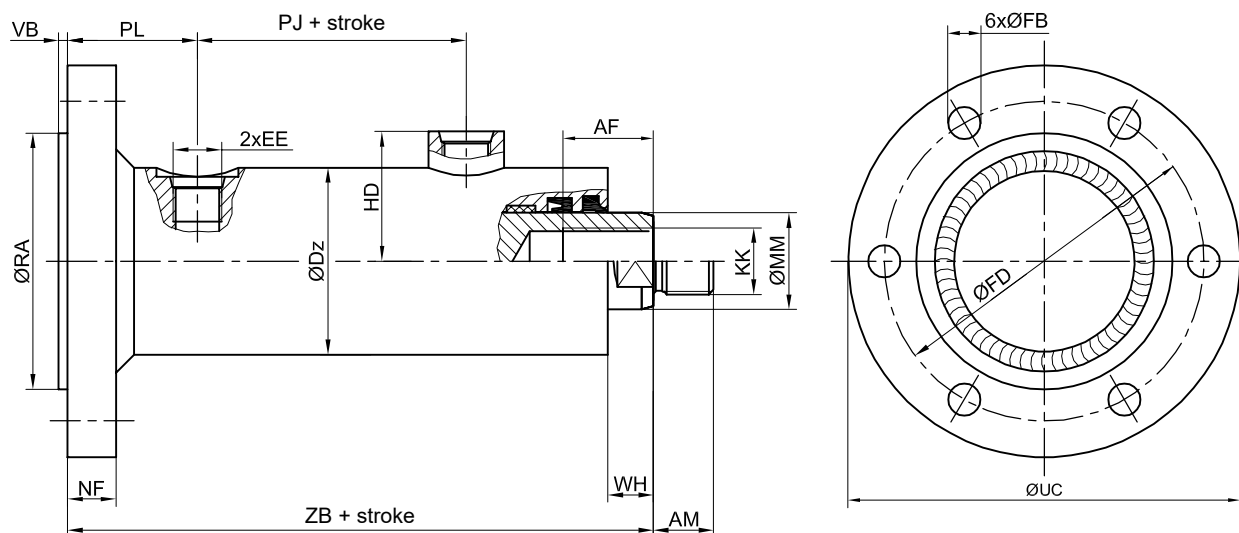

DIMENSIONS [mm]											
CYLINDER DIAMETER D	25	32	40	50	63	80	100	125	140	160	
ØMM	70	16	20	25	32	40	50	63	80	-	100
	71	18	22	22	28	36	45	56	70	80	90
AM	14	16	18	20	22	30	36	45	50	56	
AF	16	22	22	30	36	45	50	63	75	85	
ØDz	35	40	52	62	75	95	120	145	170	190	
EE	M14x1.5	M14x1.5	M16x1.5	M16x1.5	M22x1.5	M27x2	M33x2	M33x2	M33x2	M33x2	
ØFB	7	9	9	11	13.5	17	22	22	26	26	
ØFD	66	85	90	106	130	175	200	230	240	280	
HD	31	35	37	43	50	62	75	87.5	98	110	
KK	M12x1.5	M16x1.5	M16x1.5	M22x1.5	M27x2	M33x2	M42x2	M48x2	M56x2	M64x2	
NF	10	12	14	16	18	19	25	30	30	35	
PJ	58	61	64	73	85	105	124	138	155	154	
PL	30	130	37	41	46	55	62	65	60	85	
ØRA	50	60	65	85	100	135	150	180	185	240	
ØUC	80	105	110	130	160	210	240	280	288	340	
VB	2	2	3	3	3	3	5	4	5	5	
WH	12	12	10	15	15	18	20	23	26	36	
ZB	132	146	159	178	205	245	284	304	341	374	

### S2 MOUNTING

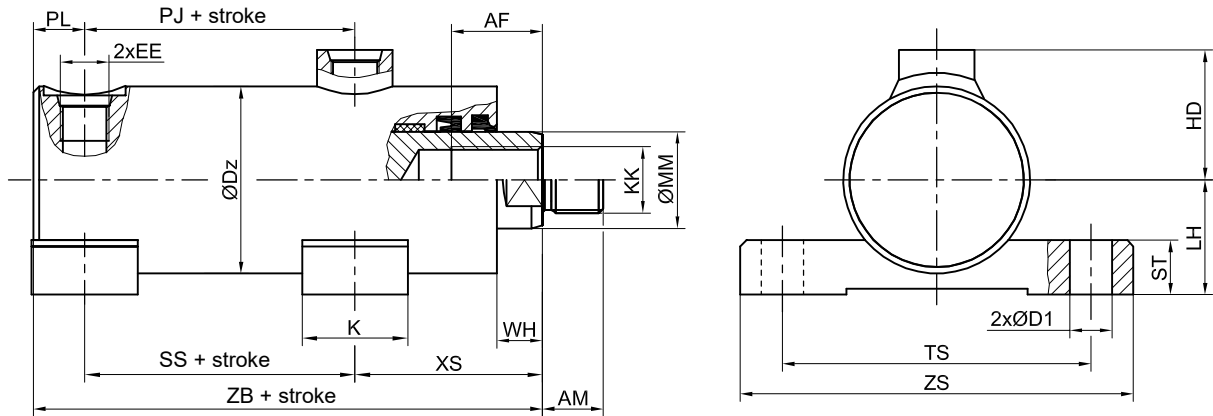

		DIMENSIONS [mm]							
CYLINDER DIAMETER D		40	50	63	80	100	125	140	160
ØMM	70	25	32	40	50	63	80	-	100
	71	22	28	36	45	56	70	80	90
AM		18	20	22	30	36	45	50	56
AF		22	30	36	45	50	63	75	85
ØDz		52	62	75	95	120	145	170	190
ØD1		11	14	20	20	26	26	30	33
EE		M16×1.5	M16×1.5	M22×1.5	M27×2	M33×2	M33×2	M33×2	M33×2
HD		37	43	50	62	75	87.5	98	110
K		30	35	50	50	50	60	70	75
KK		M16×1.5	M22×1.5	M27×2	M33×2	M42×2	M48×2	M56×2	M64×2
LH		31	38	44	57	68	85	95	115
PJ		64	73	85	105	124	138	166	154
PL		16	17	21	20	27	35	35	37
SS		64	73	85	105	124	138	166	154
ST		15	18	25	30	35	35	35	40
TS		83	102	124	149	172	205	220	250
WH		10	15	15	18	20	23	26	36
XS		58	62	74	85	96	108	115	99
ZB		138	152	180	210	247	281	316	326
ZS		110	130	165	190	240	255	280	310

### S2 MOUNTING WITH A DOUBLE-SIDED PISTON ROD

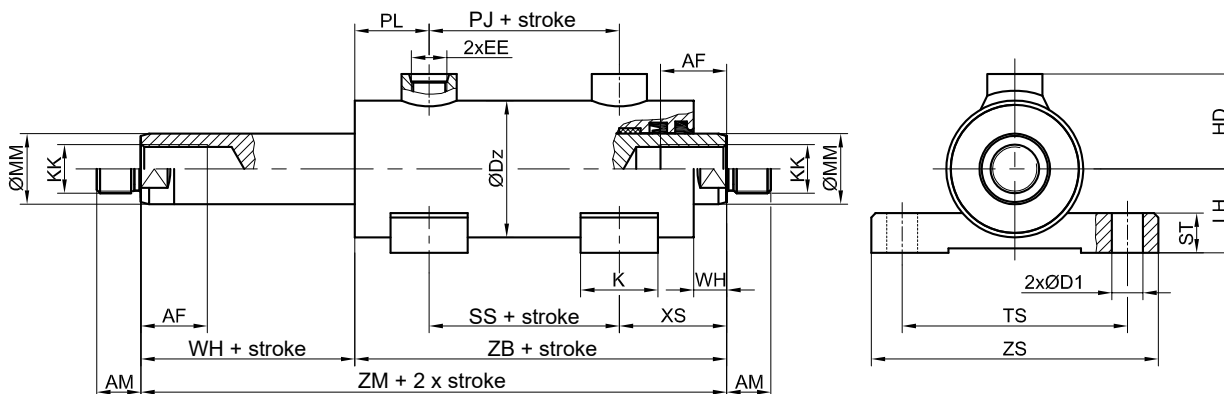

DIMENSIONS [mm]							
CYLINDER DIAMETER D		32	40	50	63	80	100
ØMM	70	20	25	32	40	50	63
	71	22	22	28	36	45	56
AM		16	18	20	22	30	36
AF		22	22	30	36	45	50
ØDz		40	52	62	75	95	120
ØD1		11	11	14	20	20	26
EE		M14×1.5	M16×1.5	M16×1.5	M22×1.5	M27×2	M33×2
HD		35	37	43	50	62	75
K		30	30	35	50	50	50
KK		M16×1.5	M16×1.5	M22×1.5	M27×2	M33×2	M42×2
LH		-	31	38	44	57	68
PJ		-	47	59	72	92	124
PL		-	48	47	59	67	86
SS		-	47	59	72	92	124
ST		-	92	18	25	30	35
TS		-	83	102	124	149	172
WH		12	10	15	15	18	20
XS		-	58	62	74	85	96
ZB		-	153	168	205	244	306
ZM		-	163	183	220	262	326
ZS		-	110	130	165	190	240

### T4 MOUNTING

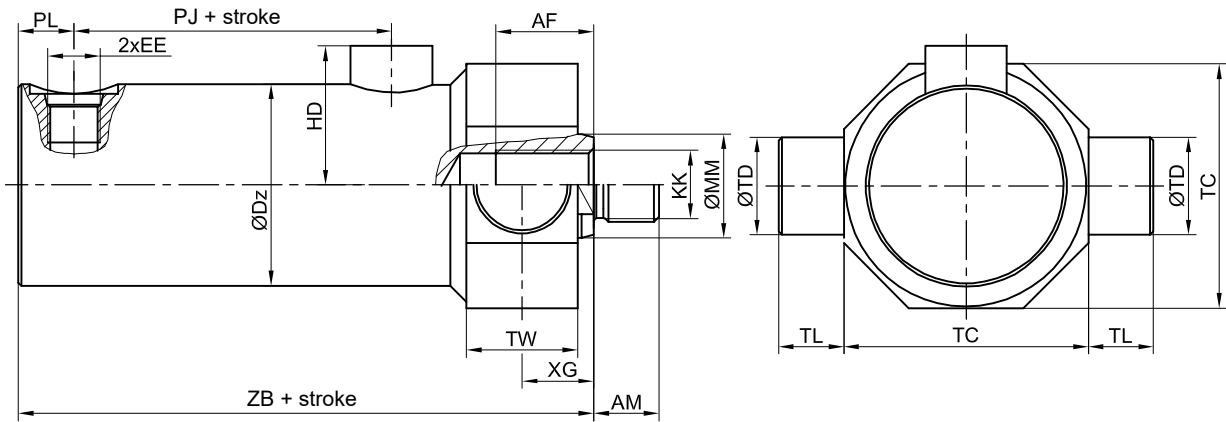

		DIMENSIONS [mm]						
CYLINDER DIAMETER D		40	50	63	80	100	125	160
ØMM	70	25	32	40	50	63	80	100
	71	22	28	36	45	56	70	90
AM		18	20	22	30	36	45	56
AF		22	30	36	45	50	63	85
ØDz		52	62	75	95	120	145	190
EE		M16x1.5	M16x1.5	M22x1.5	M27x2	M33x2	M33x2	M33x2
HD		37	43	51	62.5	75	87.5	110
KK		M16x1.5	M22x1.5	M27x2	M33x2	M42x2	M48x2	M64x2
PJ		64	73	85	105	124	135	154
PL		16	17	21	20	27	28	32
TC		65	75	95	120	150	195	240
ØTDf7		25	30	35	40	50	55	80
TL		16	20	25	31	40	50	63
TW		29	34	44	54	66	64	90
XG		21	22	25	32	53	55	50
ZB		138	152	180	210	247	274	321

# ADDITIONAL EQUIPMENT

Hydraulic cylinders

Dimension group 70; 71



## UE1...W

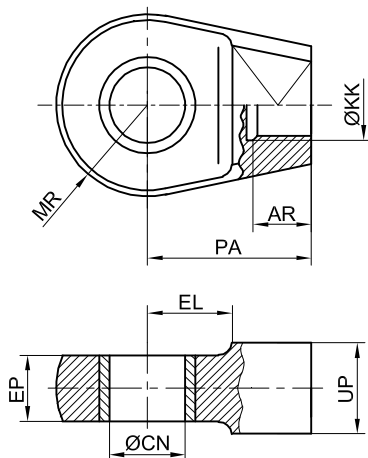

## UE2...W

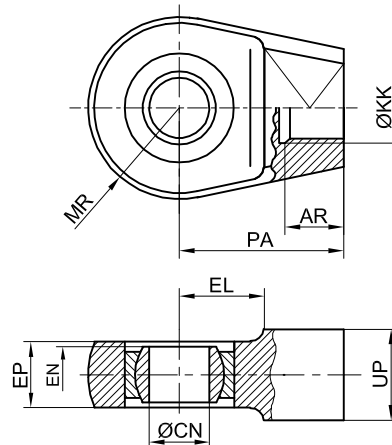

Cylinder diameter	Dimensions									Order number UE1...W	Order number UE2...W
	AR	PA	CN	MR	EP	EN	Ø KK	EL	UP		
25	16	36	16	21	14	14	M12x1.5	16	19	75.1UE1.025W	75.1UE2.025W
32	18	44	20	25	20	16	M16x1.5	22	24	75.1UE1.032W	75.1UE2.032W
40	22	50	25	30	24	20	M16x1.5	-	24	75.1UE1.040W	75.1UE2.040W
50	22	56	30	36	26	22	M22x1.5	28	30	75.1UE1.050W	75.1UE2.050W
63	28	70	35	40	31	25	M27x2	36	36	75.1UE1.063W	75.1UE2.063W
80	34	88	40	50	32	28	M33x2	45	46	75.1UE1.080W	75.1UE2.080W
100	40	105	50	60	40	35	M42x2	56	60	75.1UE1.100W	75.1UE2.100W
125	50	135	60	73	55	44	M48x2	70	75	75.1UE1.125W	75.1UE2.125W
140	56	150	70	84	60	49	M56x2	80	85	75.1UE1.140W	75.1UE2.140W
160	60	170	80	97	65	55	M64x2	90	95	75.1UE1.160W	75.1UE2.160W

## UE1...Z

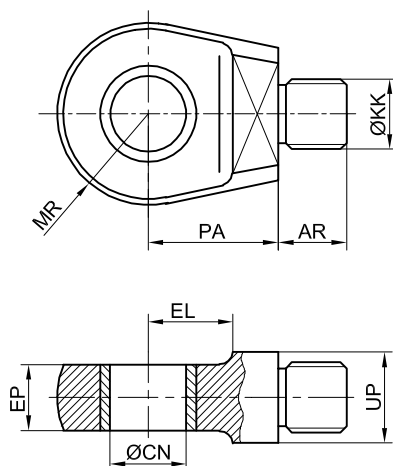

## UE2...Z

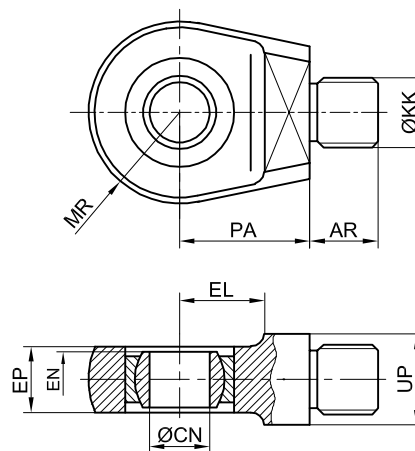

Cylinder diameter	Dimensions									Order number UE1...Z	Order number UE2...Z
	AR	PA	CN	MR	EP	EN	Ø KK	EL	UP		
40	18	36	25	30	24	20	M16x1.5	-	24	75.1UE1.040Z	75.1UE2.040Z
50	20	40	30	36	26	22	M22x1.5	28	30	75.1UE1.050Z	75.1UE2.050Z
63	22	50	35	40	31	25	M27x2	36	36	75.1UE1.063Z	75.1UE2.063Z
80	30	63	40	50	32	28	M33x2	45	46	75.1UE1.080Z	75.1UE2.080Z
100	36	75	50	60	40	35	M42x2	56	60	75.1UE1.100Z	75.1UE2.100Z
125	45	95	60	73	55	44	M48x2	70	75	75.1UE1.125Z	75.1UE2.125Z
140	50	105	70	84	60	49	M56x2	80	85	75.1UE1.140Z	75.1UE2.140Z
160	56	120	80	97	65	55	M64x2	90	95	75.1UE1.160Z	75.1UE2.160Z

### TECHNICAL SPECIFICATIONS

<b>Nominal operating pressure:</b>	16 MPa
<b>Operating temperature range:</b>	from 30°C to +80°C
<b>Max. speed, Piston rod:</b>	$v_{max} = 0.5$ m/s
<b>Medium:</b>	<ul style="list-style-type: none"> <li>- mineral oils type HL; HM; HG with viscosities from 10 to 450 cSt</li> <li>- aqueous solutions of HFC polymers with a min. 35% water content</li> <li>- HFA type oil-water emulsions with a 20% max. content of combustible parts</li> <li>- HFB type water-oil emulsions with a 60% max. content of combustible parts</li> </ul>
<b>Cylinder protection:</b>	- painted with anti-corrosion paint
<b>Materials:</b>	
<b>Body, head</b>	- structural carbon steel
<b>Piston rod</b>	- structural carbon steel, acid-resistant steel, stainless steel. Chrome-plated surfaces
<b>Seals</b>	- plastic



### USE

Plunger hydraulic cylinders are used in hydraulic systems as actuation elements. The principle of operation of the plunger cylinder is to obtain the operating movement by pressing the operating medium into the cylinder, which acting on the front of the piston rod causes it to be “pushed” outside the body. The piston rod can only be returned to its initial position by external force after the supply pressure has been removed.

### THEORETICAL PUSHING FORCE AT NOMINAL PRESSURE $P_N = 16$ MPa

Theoretical force [daN] [kG]						
cylinder diameter D	D25	D32	D40	D50	D63	D80
<b>Pushing force</b>	8.8 kN (880 kG)	14.4 kN (1440 kG)	22.6 kN (2260 kG)	35.3 kN (3530 kG)	56 kN (5600 kG)	90.4 kN (9040 kG)

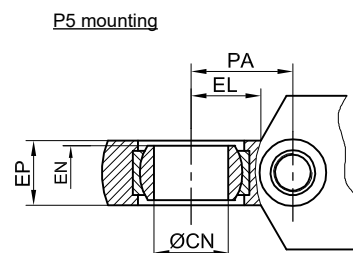
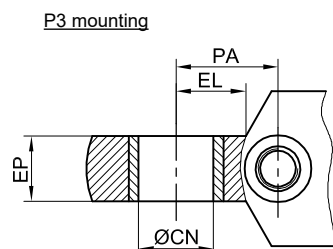
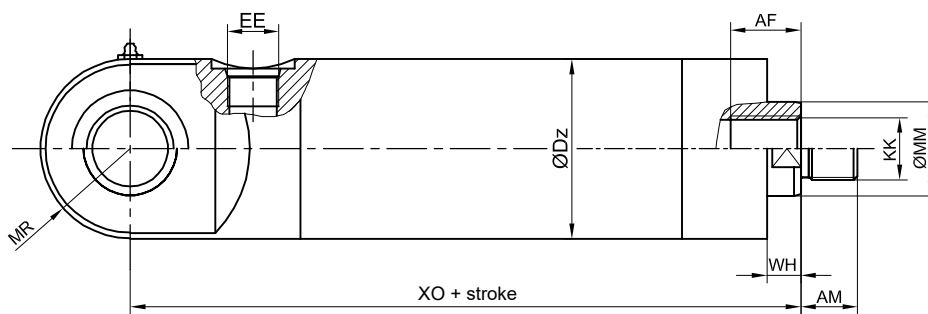

# HYDRAULIC CYLINDERS

Plunger D25 – D80

Dimension group 77



2

DIMENSIONS [mm]																	
ØMM	25			32			40			50			63			80	
AM	14			16			18			20			22			30	
AF	16			22			22			22			28			34	
ØCN	16			20			25			30			35			40	
ØDZ	48			52			62			75			95			115	
EE	M14×1.5			M14×1.5			M16×1.5			M16×1.5			M22×1.5			M27×2	
EL	16			22			26			28			36			45	
EN	14			16			20			22			25			28	
EP	12			20			24			26			31			32	
SW	21			27			30			36			55			46	
KK	M12×1.5			M16×1.5			M16×1.5			M22×1.5			M27×2			M33×2	
MR	21			25			30			36			40			50	
PA	28			34			38			41			56			65	
WH	8			15			26			29			14			49	
Stroke to	up to 200	201 to 400	up to 100	101 to 250	251 to 630	up to 100	101 to 400	401 to 1250	up to 125	126 to 800	801 to 1600	up to 200	201 to 500	501 to 1250	up to 400	401 to 1250	
X0	127	137	132	147	157	170	180	195	185	200	225	192	207	227	262	302	

## ORDER NUMBER CONSTRUCTION

**77 . G 1 P 5 . 0200 Z K**

**Code of the dimensional group (type) of the cylinder**  
77 - value of the area ratio

**Cylinder diameter code**

D - 25 mm  
E - 32 mm  
F - 40 mm  
G - 50 mm  
H - 63 mm  
J - 80 mm

**Cylinder version code**

1 - STANDARD version  
3 - for operating at high temperatures.

**Mounting type code**

P3 - bottom eye with a self-aligning bearing  
P5 - bottom eye with an articulated bearing

**Stroke [mm]**

stroke e.g. 0200=200 mm

**Piston rod tip version code**

Z - male thread  
W - female thread

**Code for piston rod material**

without designation - structural steel  
K - acid-resistant steel  
N - stainless steel  
H - induction hardened

## ORDERING PROCEDURE

In your order please specify: name, nominal diameter, actuator stroke, mounting type code, piston rod end code, order number and the number of pieces, e.g.:

**D63 x 200 hydraulic plunger cylinder with P5 mount, bottom eye with articulated bearing, male thread on piston rod, no. 70.G1P5.0200ZK 1 pc.**

### TECHNICAL SPECIFICATIONS

<b>Switching function:</b> - Normally open contact (NO)	
<b>Switch output:</b> - PNP	
<b>Rated operational voltage Ue:</b> - 24 VDC (10V-30V)	
<b>Measurement operating current Ie:</b> - 200mA	
<b>Switches mounting:</b> - M12x1	
<b>Protection class acc. to IEC 60529:</b> - IP68	
<b>Reverse polarity protection:</b> - yes	
<b>Short-circuit protection:</b> - yes	

High-pressure resistant sensors				
Actuator diameter	from -25°C to +85°C up to 350 bar	from -25°C to +85°C up to 500 bar	from -25°C to +120°C up to 500 bar	ATEX from -25°C to +85°C up to 350 bar
D25	17.124T.01	17.1232.01	17.1263.01	17.1231.01
D32				
D40				
D50				
D63				
D80	17.124P.01	17.122Y.01	17.125Y.01	17.122W.01
D100	17.124N.01	17.1249.01	17.125R.01	17.121K.01
D125				
D160		17.124C.01		

Order number
17.124T.01

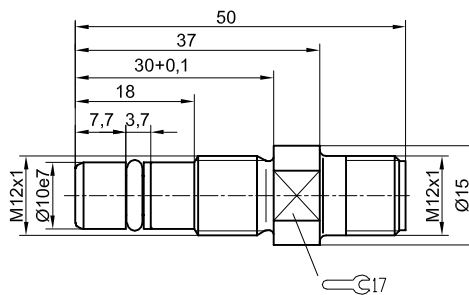

Order number
17.124P.01

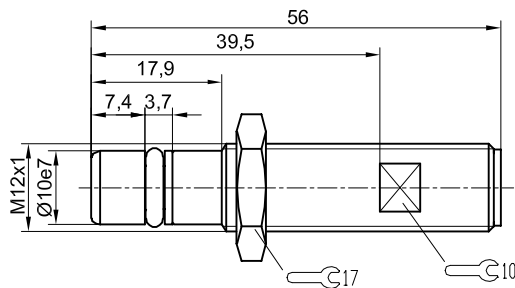

Order number
17.124N.01

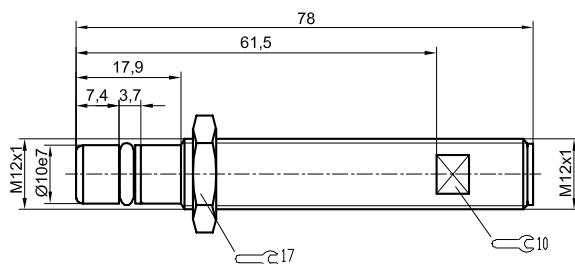



# ACCESSORIES FOR HYDRAULIC CYLINDERS

## magnetic field sensors

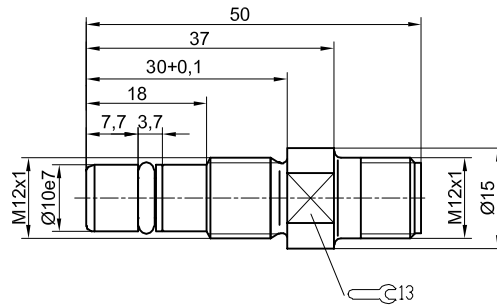

Order number
17.1232.01

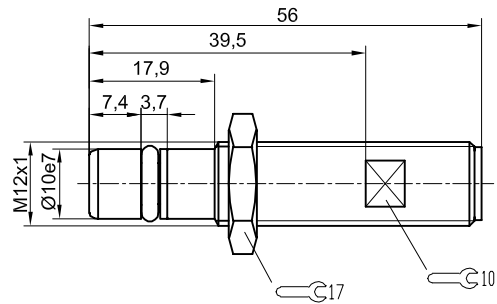

Order number
17.122Y.01

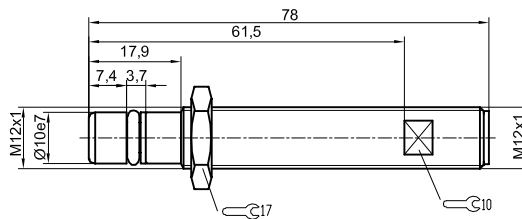

Order number
17.1249.01

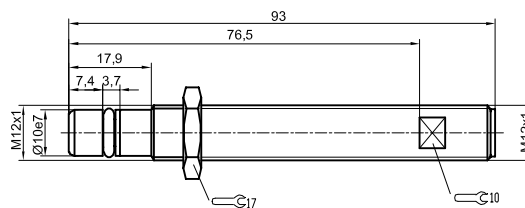

Order number
17.124C.01

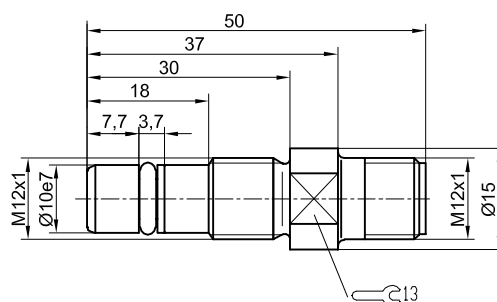

Order number
17.1231.01

Order number
17.122W.01

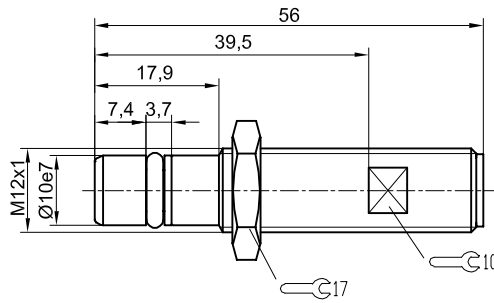

Order number
17.121K.01

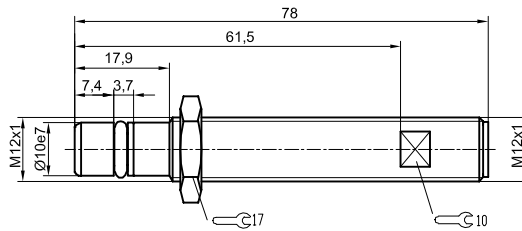

Order number
17.1263.01

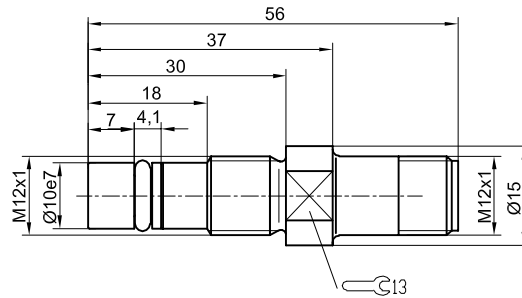

Order number
17.125Y.01

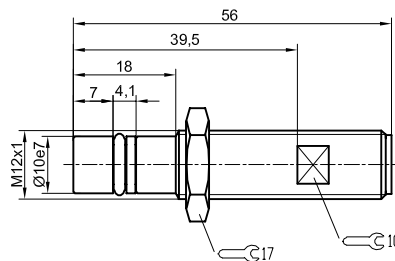

Order number
17.125R.01

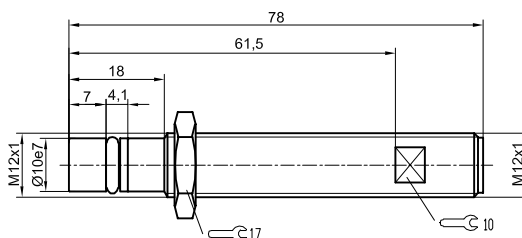

### ACCESSORIES

2

<b>PLUG</b>
<b>Type of plug:</b> - straight
<b>Conduit length:</b> - 5m
<b>Connection thread:</b> - M12x1
<b>Order number:</b> - 17.1268.02

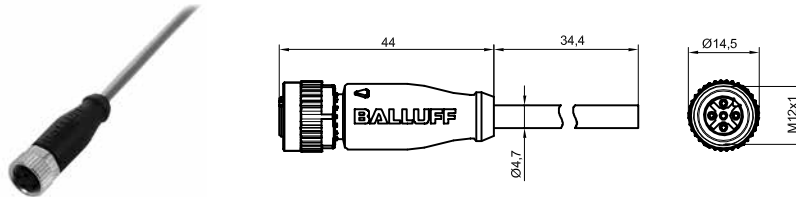

<b>PLUG</b>
<b>Type of plug:</b> - straight
<b>Conduit length:</b> - 10m
<b>Connection thread:</b> - M12x1
<b>Order number:</b> - 17.1269.02

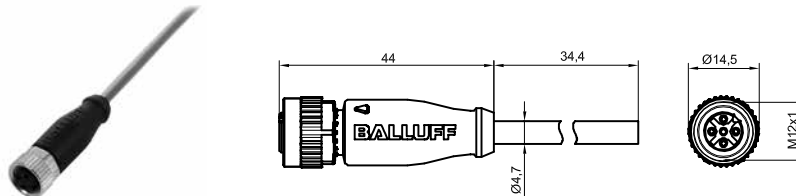

<b>PLUG</b>
<b>Type of plug:</b> - angled
<b>Conduit length:</b> - 5m
<b>Connection thread:</b> - M12x1
<b>Order number:</b> - 17.126P.02

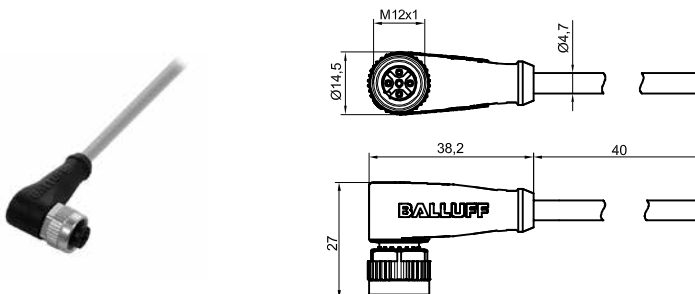

## ACCESSORIES

PLUG	
Type of plug:	- angled
Conduit length:	- 10m
Connection thread:	- M12x1
Order number:	- 17.126R.02

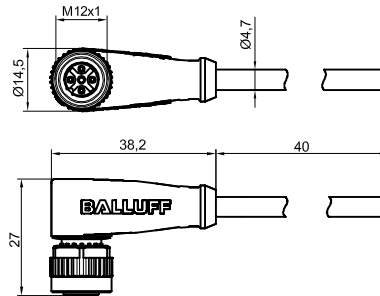

PLUG	
Type of plug:	- straight
Conduit length:	- 5m
Connection thread:	- M12x1
Order number:	- 17.12Z9.02

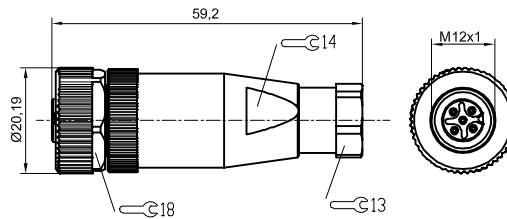

PLUG	
Type of plug:	- angled
Conduit length:	- 10m
Connection thread:	- M12x1
Order number:	- 17.12ZA.02

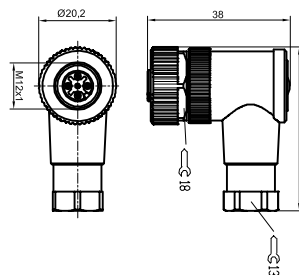

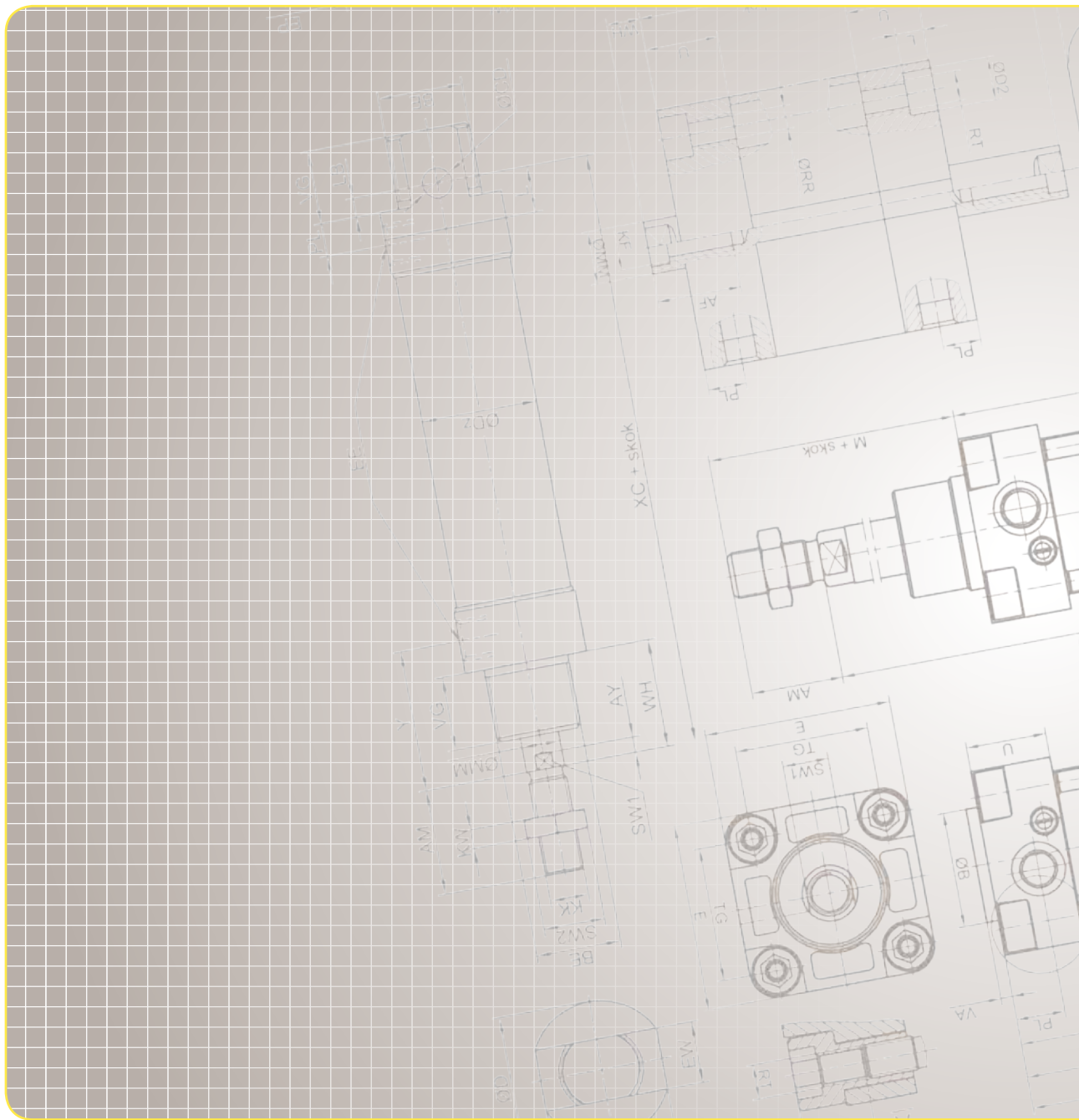

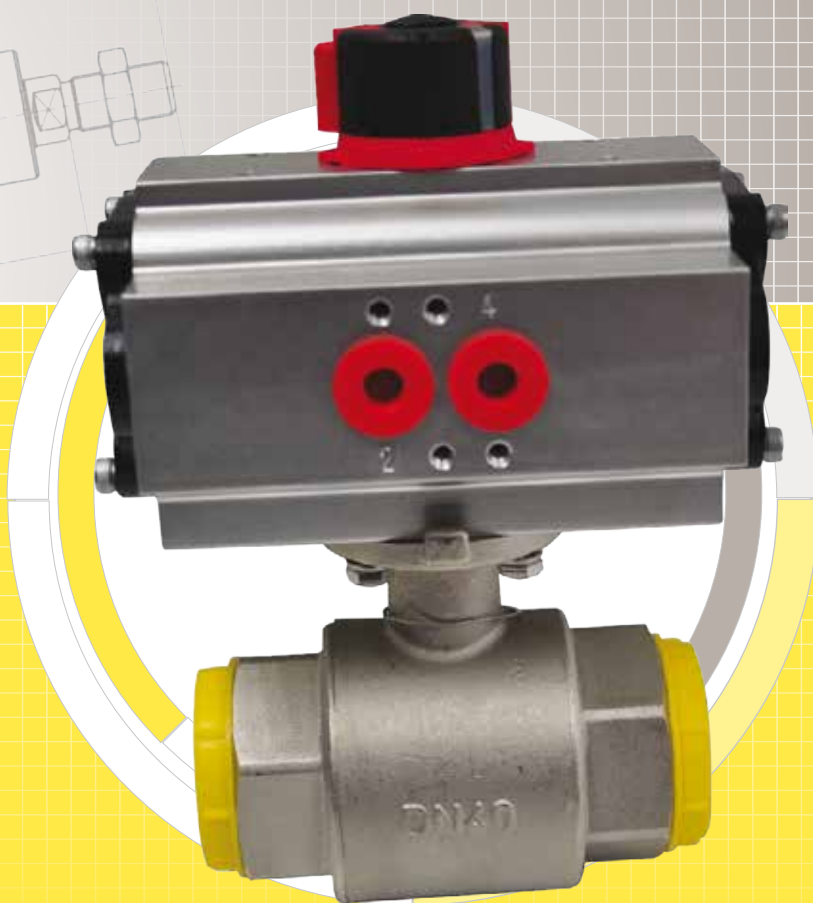

# ROTARY ACTUATORS

## Rotary actuators

- 3.01.** Rotary actuators
- 3.02.** Pneumatically and electrically operated double flange butterfly valves
- 3.03.** Pneumatically and electrically operated ball valves
- 3.04.** Double flange butterfly valves
- 3.05.** Accessories for rotary actuators

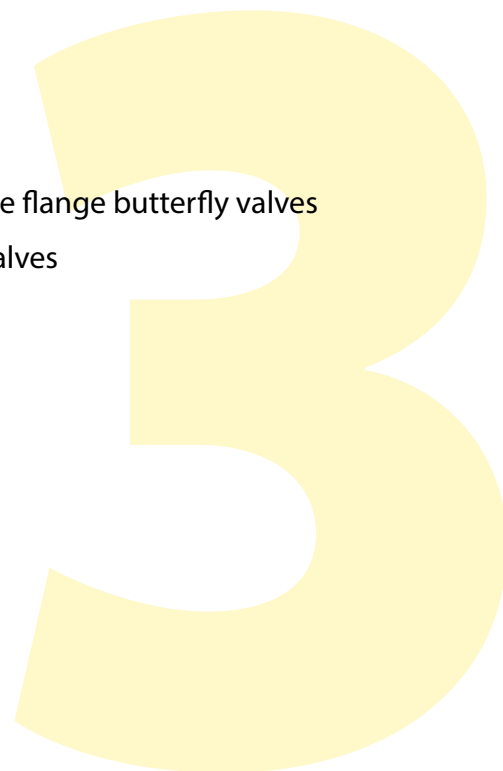

## TECHNICAL SPECIFICATIONS

<b>Operating pressure:</b>	6 bar
<b>Rotation angle</b>	90°
<b>Temperature range:</b>	from -30°C to +100°C
<b>Connection dimensions for drive elements:</b>	NAMUR G1/4
<b>Construction materials:</b>	
<b>Body</b>	- aluminium



## DOUBLE-ACTING ACTUATOR

Value	Torque [Nm] at 6 bar airflow	ISO	Rod	Order numbers
20	19	F5	14	85.0001.ADA20
40	41	F5	14	85.0001.ADA40
80	77	F5/F7	17	85.0001.ADA80
130	118	F5/F7	17	85.0001.ADA130
200	175	F7/F10	17	85.0001.ADA200
300	291	F7/F10	22	85.0001.ADA300
500	433	F10	22	85.0001.ADA500
850	718	F10/F12	27	85.0001.ADA850
1200	1038	F10/F14	36	85.0001.ADA1200
1750	1413	F14	36	85.0001.ADA1750

## SINGLE-ACTING ACTUATOR, SPRING RETURN

Value	Torque [Nm] at 6 bar airflow		ISO	Rod	Order numbers
	air opening	spring closing			
20	14	10	F5	14	85.0001.ASR20
40	26	17	F5	14	85.0001.ASR40
80	51	37	F5/F7	17	85.0001.ASR80
130	80	64	F5/F7	17	85.0001.ASR130
200	113	84	F7/F10	17	85.0001.ASR200
300	190	126	F7/F10	22	85.0001.ASR300
500	283	205	F10	22	85.0001.ASR500
850	488	367	F10/F12	27	85.0001.ASR850
1200	698	502	F10/F14	36	85.0001.ASR1200
1750	877	578	F14	36	85.0001.ASR1750



# ROTARY ACTUATORS

## double flange butterfly valves

### pneumatically and electrically operated



#### TECHNICAL SPECIFICATIONS

<b>Temperature range:</b>	from -10°C to +90°C for version 1121 from -10°C to +110°C
<b>Max. operating pressure</b>	16 bar
<b>Construction materials:</b>	<p><b>Body</b> - cast iron</p> <p><b>Seals</b> - EPDM, NBR</p> <p><b>Flap</b> - stainless steel, cast iron</p>



Value	Order numbers							
	2-way operation				spring return			
	1150	1151	1152	1153	1150	1151	1152	1153
<b>32-40</b>	85.1150.DA040	85.1151.DA040	85.1152.DA040	85.1153.DA040	85.1150.SR040	85.1151.SR040	85.1152.SR040	85.1153.SR040
<b>50</b>	85.1150.DA050	85.1151.DA050	85.1152.DA050	85.1153.DA050	85.1150.SR050	85.1151.SR050	85.1152.SR050	85.1153.SR050
<b>65</b>	85.1150.DA065	85.1151.DA065	85.1152.DA065	85.1153.DA065	85.1150.SR065	85.1151.SR065	85.1152.SR065	85.1153.SR065
<b>80</b>	85.1150.DA080	85.1151.DA080	85.1152.DA080	85.1153.DA080	85.1150.SR080	85.1151.SR080	85.1152.SR080	85.1153.SR080
<b>100</b>	85.1150.DA100	85.1151.DA100	85.1152.DA100	85.1153.DA100	85.1150.SR100	85.1151.SR100	85.1152.SR100	85.1153.SR100
<b>125</b>	85.1150.DA125	85.1151.DA125	85.1152.DA125	85.1153.DA125	85.1150.SR125	85.1151.SR125	85.1152.SR125	85.1153.SR125
<b>150</b>	85.1150.DA150	85.1151.DA150	85.1152.DA150	85.1153.DA150	85.1150.SR150	85.1151.SR150	85.1152.SR150	85.1153.SR150
<b>200</b>	85.1150.DA200	85.1151.DA200	85.1152.DA200	85.1153.DA200	85.1150.SR200	85.1151.SR200	85.1152.SR200	85.1153.SR200
<b>250</b>	85.1150.DA250	85.1151.DA250	85.1152.DA250	85.1153.DA250	85.1150.SR250	85.1151.SR250	85.1152.SR250	85.1153.SR250
<b>300</b>	85.1150.DA300	85.1151.DA300	85.1152.DA300	85.1153.DA300	85.1150.SR300	85.1151.SR300	85.1152.SR300	85.1153.SR300
<b>400</b>	85.1150.DA400	85.1151.DA400	85.1152.DA400	85.1153.DA400	85.1150.SR400	85.1151.SR400	85.1152.SR400	85.1153.SR400

#### TECHNICAL SPECIFICATIONS

<b>Temperature range:</b>	from -10°C to +110°C
<b>Max. operating pressure</b>	16 bar
<b>Construction materials:</b>	<p><b>Body</b> - cast iron</p> <p><b>Bracket</b> - aluminium</p> <p><b>Seals</b> - NBR</p> <p><b>Flap</b> - stainless steel, nickel-plated cast iron</p>



Connection thread	Order number	
	2-way operation	spring return
<b>32-40</b>	85.1135.DA040	85.1135.SR040
<b>50</b>	85.1135.DA050	85.1135.SR050
<b>65</b>	85.1135.DA065	85.1135.SR065
<b>80</b>	85.1135.DA080	85.1135.SR080
<b>100</b>	85.1135.DA100	85.1135.SR100
<b>125</b>	85.1135.DA125	85.1135.SR125
<b>150</b>	85.1135.DA150	85.1135.SR150
<b>200</b>	85.1135.DA200	85.1135.SR200
<b>250</b>	85.1135.DA250	85.1135.SR250
<b>300</b>	85.1135.DA300	85.1135.SR300

#### TECHNICAL SPECIFICATIONS

<b>Temperature range:</b>	from 10°C to +110°C for versions 1125 and 1123 from 10°C to +90°C for version 1121
<b>Max. operating pressure</b>	16 bar
<b>Construction materials:</b>	
<b>Body</b>	- cast iron GG25
<b>Seals</b>	- EPDM (version 1125/1123), NBR (version 1121)
<b>Disc</b>	- for version 1125 - disc made of nickel-plated cast iron GGG40 - for version 1123, 1121 disc made of stainless steel CF8M

Value	Order number					
	2-way operation			spring return		
	1125	1123	1121	1125	1123	1121
<b>32-40</b>	85.1125.DA040	85.1123.DA040	85.1121.DA040	85.1125.SR040	85.1123.SR040	85.1121.SR040
<b>50</b>	85.1125.DA050	85.1123.DA050	85.1121.DA050	85.1125.SR050	85.1123.SR050	85.1121.SR050
<b>65</b>	85.1125.DA065	85.1123.DA065	85.1121.DA065	85.1125.SR065	85.1123.SR065	85.1121.SR065
<b>80</b>	85.1125.DA080	85.1123.DA080	85.1121.DA080	85.1125.SR080	85.1123.SR080	85.1121.SR080
<b>100</b>	85.1125.DA100	85.1123.DA100	85.1121.DA100	85.1125.SR100	85.1123.SR100	85.1121.SR100
<b>125</b>	85.1125.DA125	85.1123.DA125	85.1121.DA125	85.1125.SR125	85.1123.SR125	85.1121.SR125
<b>150</b>	85.1125.DA150	85.1123.DA150	85.1121.DA150	85.1125.SR150	85.1123.SR150	85.1121.SR150
<b>200</b>	85.1125.DA200	85.1123.DA200	85.1121.DA200	85.1125.SR200	85.1123.SR200	85.1121.SR200
<b>250</b>	85.1125.DA250	85.1123.DA250	85.1121.DA250	85.1125.SR250	85.1123.SR250	85.1121.SR250
<b>300</b>	85.1125.DA300	85.1123.DA300	85.1121.DA300	85.1125.SR300	85.1123.SR300	85.1121.SR300



#### TECHNICAL SPECIFICATIONS

<b>Temperature range:</b>	from -10°C to +110°C
<b>Max. operating pressure</b>	16 bar
<b>Construction materials:</b>	
<b>Body</b>	- cast iron GG25
<b>Seals</b>	- EPDM
<b>Disc</b>	- stainless steel CF8M

Value	Order number	
	UM/UV	SA/NA*
<b>32-40</b>	85.UMUV.3240	85.SANA.3240
<b>50</b>	85.UMUV.0050	85.SANA.0050
<b>65</b>	85.UMUV.0065	85.SANA.0065
<b>80</b>	85.UMUV.0080	85.SANA.0080
<b>100</b>	85.UMUV.0100	85.SANA.0100
<b>125</b>	85.UMUV.0125	85.SANA.0125
<b>150</b>	85.UMUV.0150	85.SANA.0150
<b>200</b>	85.UMUV.0200	85.SANA.0200
<b>250</b>	85.UMUV.0250	85.SANA.0250
<b>300</b>	85.UMUV.0300	85.SANA.0300

\*version with butterfly valve position indicator



# ROTARY ACTUATORS

pneumatically and electrically operated  
ball valves



## TECHNICAL SPECIFICATIONS

<b>Temperature range:</b>	from -10°C to +100°C
<b>Max. operating pressure</b>	10 bar
<b>Construction materials:</b>	
<b>Body</b>	- brass CW617N
<b>Ball</b>	- brass CW617N
<b>Seals</b>	- NBR, PTFE

## 2-WAY VALVE



Connection thread	Order numbers	
	2-way operation	spring return
<b>G1/4</b>	85.0502.DA014	85.0502.SR014
<b>G3/8</b>	85.0502.DA038	85.0502.SR038
<b>G1/2</b>	85.0502.DA012	85.0502.SR012
<b>G3/4</b>	85.0502.DA034	85.0502.SR034
<b>G1</b>	85.0502.DA100	85.0502.SR100
<b>G1 1/4</b>	85.0502.DA114	85.0502.SR114
<b>G1 1/2</b>	85.0502.DA112	85.0502.SR112
<b>G2</b>	85.0502.DA200	85.0502.SR200
<b>G2 1/2</b>	85.0502.DA212	85.0502.SR212
<b>G3</b>	85.0502.DA300	85.0502.SR300
<b>G4</b>	85.0502.DA400	85.0502.SR400

## 3-WAY VALVE



Connection thread	Order number			
	Type L		Type T	
	2-way operation	spring return	2-way operation	spring return
<b>G1/4</b>	85.0513.DA014	85.0513.SR014	85.0514.DA014	85.0514.SR014
<b>G3/8</b>	85.0513.DA038	85.0513.SR038	85.0514.DA038	85.0514.SR038
<b>G1/2</b>	85.0513.DA1012	85.0513.SR012	85.0514.DA1012	85.0514.SR012
<b>G3/4</b>	85.0513.DA034	85.0513.SR034	85.0514.DA034	85.0514.SR034
<b>G1</b>	85.0513.DA100	85.0513.SR100	85.0514.DA100	85.0514.SR100
<b>G1 1/4</b>	85.0513.DA114	85.0513.SR114	85.0514.DA114	85.0514.SR114
<b>G1 1/4</b>	85.0513.DA112	85.0513.SR112	85.0514.DA112	85.0514.SR112
<b>G2</b>	85.0513.DA200	85.0513.SR200	85.0514.DA200	85.0514.SR200

## TECHNICAL SPECIFICATIONS

<b>Temperature range:</b>	from -10°C to +100°C
<b>Max. operating pressure</b>	10 bar
<b>Construction materials:</b>	
<b>Body</b>	- brass CW617N
<b>Ball</b>	- brass CW617N
<b>Seals</b>	- NBR, PTFE



Value	Order numbers					
	Ball valve		3-way valve type L		3-way valve type T	
	UM	SA*	UM	SA*	UM	SA*
<b>G1/4</b>	85.0502.UM014	85.0502.SA014	85.0513.UM014	85.0513.SA014	85.0514.UM014	85.0514.SA014
<b>G3/8</b>	85.0502.UM038	85.0502.SA038	85.0513.UM038	85.0513.SA038	85.0514.UM038	85.0514.SA038
<b>G1/2</b>	85.0502.UM012	85.0502.SA012	85.0513.UM012	85.0513.SA012	85.0514.UM012	85.0514.SA012
<b>G3/4</b>	85.0502.UM034	85.0502.SA034	85.0513.UM034	85.0513.SA034	85.0514.UM034	85.0514.SA034
<b>G1</b>	85.0502.UM100	85.0502.SA100	85.0513.UM100	85.0513.SA100	85.0514.UM100	85.0514.SA100
<b>G1 1/4</b>	85.0502.UM114	85.0502.SA114	85.0513.UM114	85.0513.SA114	85.0514.UM114	85.0514.SA114
<b>G1 1/2</b>	85.0502.UM112	85.0502.SA112	85.0513.UM112	85.0513.SA112	85.0514.UM112	85.0514.SA112
<b>G2</b>	85.0502.UM200	85.0502.SA200	85.0513.UM200	85.0513.SA200	85.0514.UM200	85.0514.SA200
<b>G2 1/2</b>	85.0502.UM212	85.0502.SA212	85.0513.UM212	85.0513.SA212	85.0514.UM212	85.0514.SA212
<b>G3</b>	85.0502.UM300	85.0502.SA300	85.0513.UM300	85.0513.SA300	85.0514.UM300	85.0514.SA300
<b>G4</b>	85.0502.UM400	85.0502.SA400	85.0513.UM400	85.0513.SA400	85.0514.UM400	85.0514.SA400

\*Version with valve position indicator

### TECHNICAL SPECIFICATIONS

<b>Temperature range:</b>	from -10°C to +110°C
<b>Max. operating pressure</b>	16 bar
<b>Construction materials:</b>	
<b>Body</b>	- cast iron GG25
<b>Seals</b>	- EPDM
<b>Disc</b>	- nickel-plated cast iron GGG40

Value	Order numbers	
	hand lever	drive geared*
	1125	1125
32-40	85.1125.040	-
50	85.1125.050	-
65	85.1125.065	-
80	85.1125.080	-
100	85.1125.100	85.1125.102
125	85.1125.125	85.1125.107
150	85.1125.150	85.1125.152
200	85.1125.200	85.1125.202
250	85.1125.250	85.1125.252
300	85.1125.300	85.1125.302



\* sizes 350 – 1000 mm provided after prior technical consultation

### TECHNICAL SPECIFICATIONS

<b>Temperature range:</b>	from -10°C to +110°C
<b>Max. operating pressure</b>	16 bar
<b>Construction materials:</b>	
<b>Body</b>	- cast iron
<b>Seals</b>	- EPDM
<b>Disc</b>	- for version 1135 - disc made of nickel-plated cast iron GGG40 - for version 1133 disc made of stainless steel CF8M

Value	Order numbers			
	hand lever		geared drive	
	1135	1133	1135	1133
40	85.1135.040L	85.1133.040L	-	-
50	85.1135.050L	85.1133.050L	-	-
65	85.1135.065L	85.1133.060L	-	-
80	85.1135.080L	85.1133.080L	-	-
100	85.1135.100L	85.1133.100L	85.1135.100G	85.1133.100G
125	85.1135.125L	85.1133.125L	85.1135.125G	85.1133.125G
150	85.1135.150L	85.1133.150L	85.1135.150G	85.1133.150G
200/10*	85.1135.200L	85.1133.200L	85.1135.200G	85.1133.200G
200/16*	85.1135.201L	85.1133.201L	85.1135.201G	85.1133.201G
250/10*	85.1135.250L	85.1133.250L	85.1135.250G	85.1133.250G
250/16**	85.1135.251L	85.1133.251L	85.1135.251G	85.1133.251G
300/10*	85.1135.300L	85.1133.300L	85.1135.300G	85.1133.300G
300/16**	85.1135.301L	85.1133.301L	85.1135.301G	85.1133.301G



Note: when ordering, please specify the mounting option:

\* mounting acc. to PN10

\*\* mounting acc. to PN16

## LIMIT SWITCHES



### SP - Universal limit switches IP 65

Type	Description	Order number
SP 012	two mechanical SPDT contacts, silver coated 250V - 5A	85.0460.012N
SP 732	two inductive sensors PNP 10 - 30V DC P+F NBB2 V3 E2	85.0460.014N

Material: plastic



### APL - Limit switches IP 67 for ADA/ASR actuators

Type	Description	Order number
APL 210	two mechanical contacts SPDT 250V - 5A	85.0460.000N

Material: aluminium



### SM - Universal limit switches IP 65

Type	Description	Order number
SM 012	two mechanical SPDT contacts, silver coated 250V - 5A	85.0460.512N
SM 732	two inductive sensors PNP 10 - 30V DC P+F NBB2 V3 E2	85.0460.514N

Material: aluminium



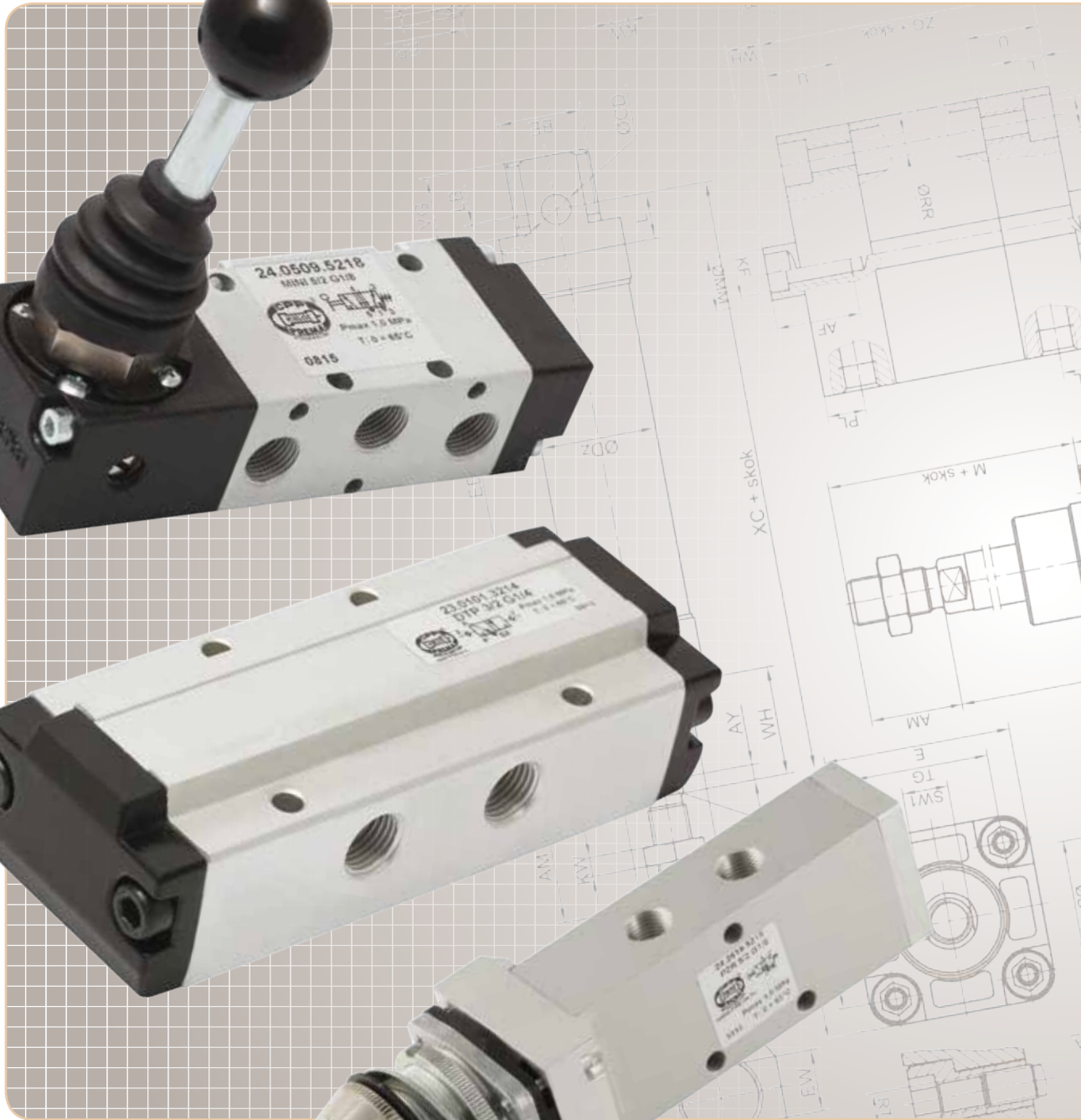
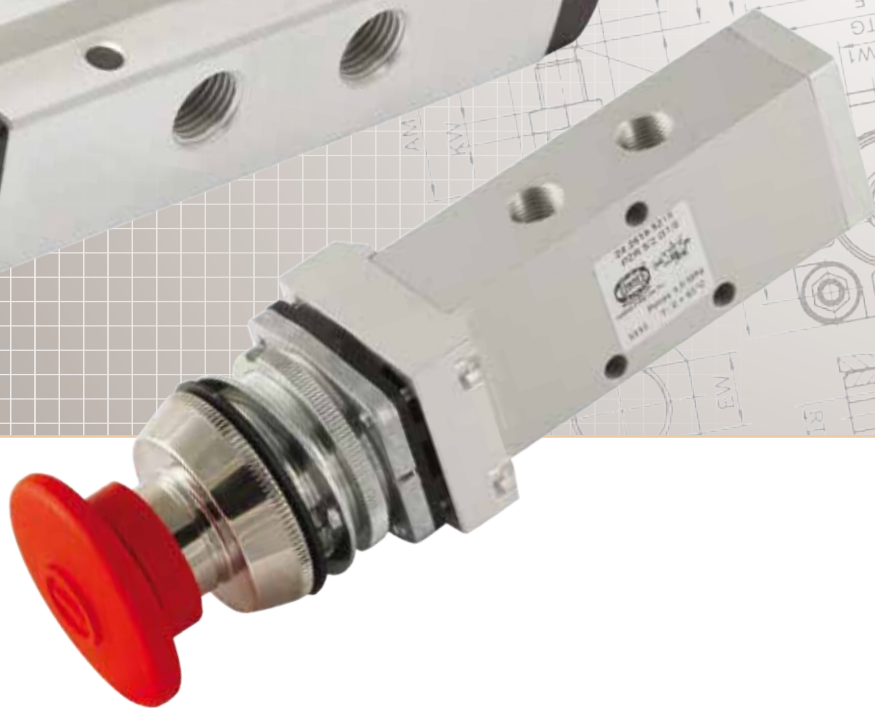

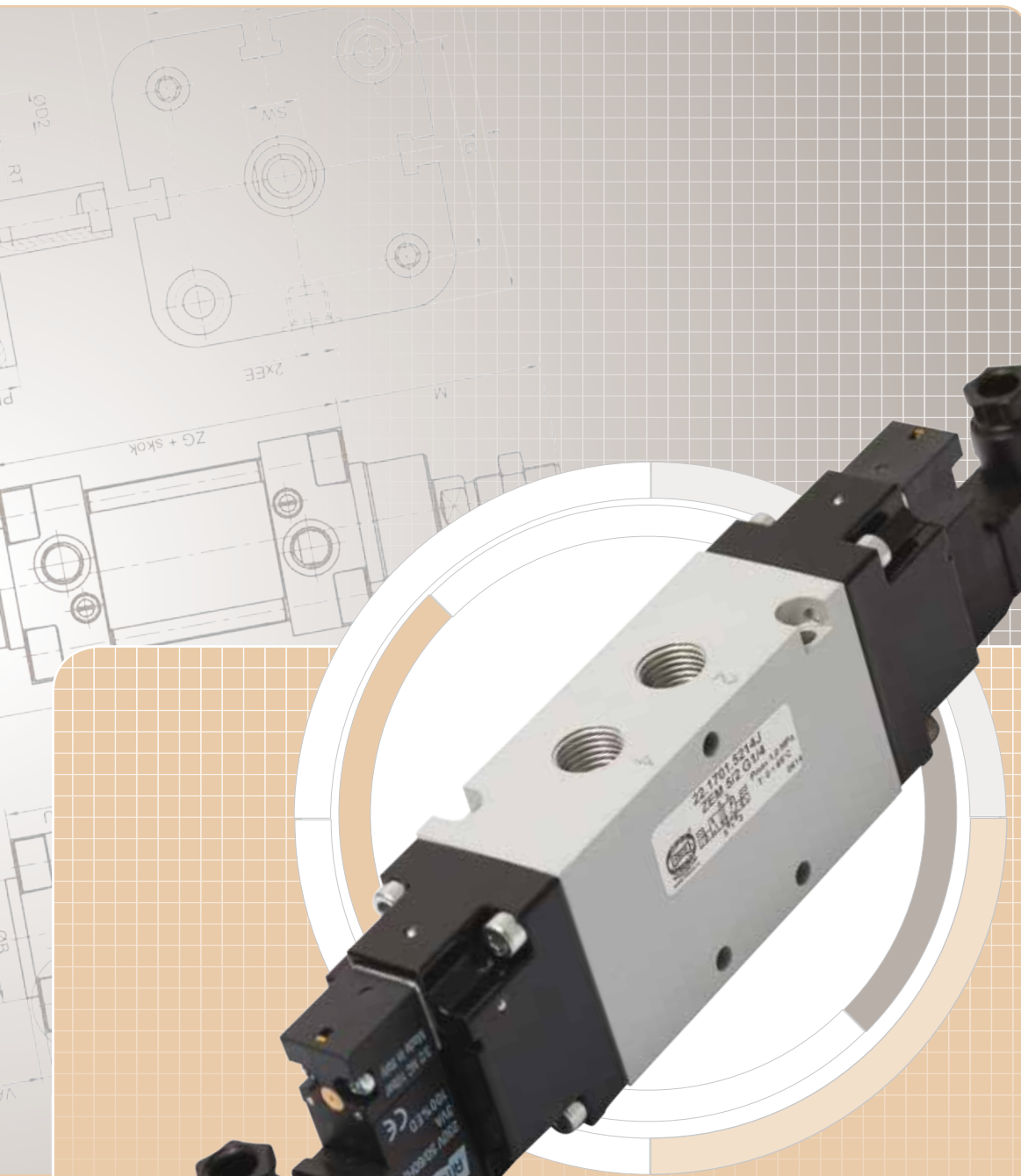











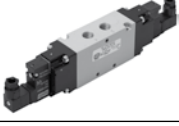

# DISTRIBUTION VALVES

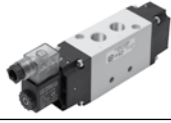























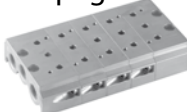





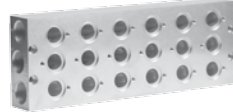

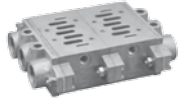
## Distribution valves

- 4.01.** Electromagnetically operated cut-off valves
- 4.02.** Electromagnetically operated distribution valves
  - 4.02.01.** ZMG series
  - 4.02.02.** ZMG NAMUR series
  - 4.02.03.** ZEM series
  - 4.02.04.** ZEM NAMUR series
  - 4.02.05.** ZE series
  - 4.02.06.** ZDE series
  - 4.02.07.** ZE ISO 5599/1 sSeries
  - 4.02.08.** ISO 5599/1 series
  - 4.02.09.** DTE series
- 4.03.** Pneumatically operated valves
  - 4.03.01.** ZMGP series
  - 4.03.02.** ZP series
  - 4.03.03.** ISO 5599/1 series
  - 4.03.04.** DTP series
  - 4.03.05.** Two-hand control block
  - 4.03.06.** Distribution valve with bottom plate supply
- 4.04.** Mechanically operated valves
  - 4.04.01.** TM series
  - 4.04.02.** DTM series
  - 4.04.03.** PM series
  - 4.04.04.** PZR series
  - 4.04.05.** PZR MINI series
  - 4.04.06.** PP series
  - 4.04.07.** Cut-off valves
- 4.05.** Subplates
- 4.06.** Repair kits



	<b>ZMG series</b>	Distribution valves 3/2, 5/2, 5/3	G1/8, G1/4	page 4.02.01
	<b>ZMG NAMUR series</b>	Distribution valves 3/2, 5/2, 5/3 with NAMUR connection	G1/8, G1/4	page 4.02.02
	<b>ZEM series</b>	Distribution valves 3/2, 5/2, 5/3	G1/8, G1/4	page 4.02.03
	<b>ZEM NAMUR series</b>	Distribution valves 3/2, 5/2, 5/3 with NAMUR connection	G1/8, G1/4	page 4.02.04
	<b>ZE series</b>	Distribution valves 3/2, 3/3, 5/2, 5/3	G3/8	page 4.02.05
	<b>ZDE series</b>	Distribution valves 3/2, 3/3, 5/2, 5/3	G1/2	page 4.02.06
	<b>ZE ISO series</b>	Distribution valves 3/2, 3/3, 5/2, 5/3 compliant with ISO 5599/1 size 2	G1/4-G3/8	page 4.02.07
	<b>ISO series</b>	Distribution valves 3/2, 3/3, 5/2, 5/3 compliant with ISO 5599/1 size 2	G1/4-G3/8	page 4.02.08
	<b>DTE series</b>	Distribution valves 3/2, 3/3, 5/2, 5/3, 5/3 - plate	G1/8- G3/4	page 4.02.09.05
	<b>DTE series</b>	Distribution valves 3/2, 3/3, 5/2, 5/3 - wired	G1/8, G1/4	page 4.02.09.01
	<b>ZMGP series</b>	Distribution valves 3/2, 5/2, 5/3 - wired	G1/8, G1/4	page 4.03.01.01
	<b>ZP series</b>	Distribution valves 3/2, 5/2, 5/3	G3/8	page 4.03.02.01
	<b>ISO series</b>	Distribution valves 5/2, 5/3 compliant with ISO 5599/1 size 2	G3/8	page 4.03.03.01

	<b>DTP series</b>	Distribution valves 3/2, 3/3, 5/2, 5/3, 5/3 - plate	G1/8- G3/4	page 4.03.04.07
	<b>DTP series</b>	Distribution valves 3/2, 3/3, 5/2, 5/3 - wired	G1/8, G1/4	page 4.03.04.01
	<b>Two-hand control block</b>		G1/8	page 4.03.05.01
	<b>Distribution valve with bottom plate supply</b>	Distribution valve 5/2 with bottom plate supply	G1/8	page 4.03.06.01
	<b>TM series</b>	Distribution valves 3/2, 5/2, 5/3 - wired	G1/8, G1/4	page 4.04.01.01
	<b>DTM series</b>	Distribution valves 3/2, 3/3, 5/2, 5/3, 5/3 - plate	G1/8- G3/4	page 4.04.02.09
	<b>DTM series</b>	Distribution valves 3/2, 3/3, 5/2, 5/3 - wired	G1/8, G1/4	page 4.04.02.01
	<b>PM series</b>	Distribution valves - plate 4/3	G1/8, G3/8, G1/2, G3/4	page 4.04.03.01
	<b>PZR series</b>	Distribution valves 2/2, 3/2, 5/2 - pilots	G1/8	page 4.04.04.01
	<b>PZR MINI series</b>	Distribution valves 2/2, 3/2	Ø4, M5	page 4.04.05.01
	<b>PP series</b>	Distribution valve 5/2	G1/4	page 4.04.06.01

		solid subplates	segmented subplates
	ZMG series	page  4.05.01	page  4.05.03
	ZEM series	page  4.05.05	page  4.05.07
	ZE series	page  4.05.11	
	ZDE series	page  4.05.09	
	ISO series	page 4.05.20	page  4.05.21
	series DTE	page  4.05.15	page  4.05.13
	DTP series	page  4.05.15	page  4.05.13
	DTM series	page  4.05.15	page  4.05.13



## TECHNICAL SPECIFICATIONS

<b>Operating pressure range:</b>	0 - 10 bar
<b>Operating temperature range:</b>	-10 to + 50°C
<b>Medium:</b>	compressed air, filtered, lubricated or non-lubricated
<b>Control voltage</b>	direct current: B - 24 V
<b>designation "x" in the order number:</b>	50 Hz alternating current: E - 24 V J - 230 V
<b>Solenoid supply voltage:</b>	230 V AC and 24 V DC +/- 10%
<b>Power consumption for the direct current:</b>	10W
<b>Power consumption for the alternating current:</b>	10VA
<b>Electrical protection:</b>	IP 65
<b>Construction materials:</b>	<b>Body</b> - aluminium alloy <b>Nozzle</b> - brass <b>Seals</b> - NBR rubber

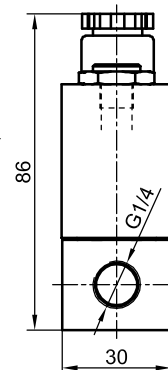
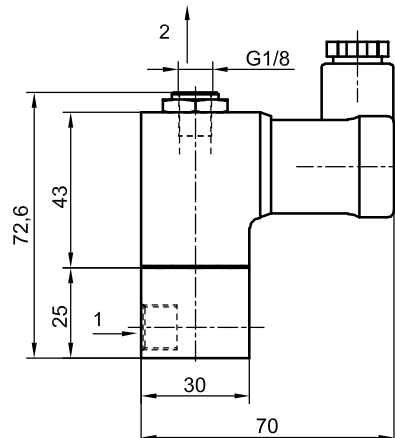
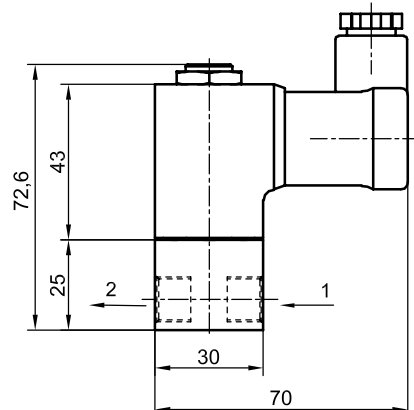
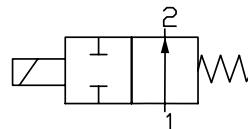
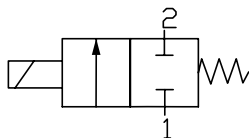

# CUT-OFF VALVE

electromagnetically operated, directly



## ORDER NUMBERS

Connection thread	Graphical symbol	Position	Order number		
			24V DC voltage	230 V AC voltage	24V AC voltage
G1/4		Normally closed	<b>50.5330.2214B</b>	<b>50.5330.2214J</b>	<b>50.5330.2214E</b>
		Normally open	<b>50.5324.2214NOB</b>	<b>50.5324.2214NOJ</b>	<b>50.5324.2214NOE</b>

## ORDERING PROCEDURE

In your order, please specify the name of the valve, connection thread, order number and number of pieces, e.g.:

**Cut-off valve 2/2 G1/4 NO electromagnetically operated, 230 V AC no. 50.5324.2214NOJ 1 pc.**

## TECHNICAL SPECIFICATIONS

<b>Operating pressure range:</b>	0 - 10 bar
<b>Operating temperature range:</b>	-10 to + 50°C
<b>Medium:</b>	compressed air, filtered, lubricated or non-lubricated
<b>Control voltage</b>	direct current: B - 24 V
<b>designation "x" in the order number:</b>	50 Hz alternating current: E - 24 V    J - 230 V
<b>Solenoid supply voltage:</b>	230 V AC and 24 V DC
<b>Power consumption for the direct current:</b>	10W
<b>Power consumption for the alternating current:</b>	10VA
<b>Electrical protection:</b>	IP 65
<b>Construction materials:</b>	<b>Body</b> - aluminium alloy <b>Nozzle</b> - brass <b>Seals</b> - NBR rubber

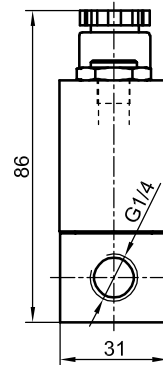
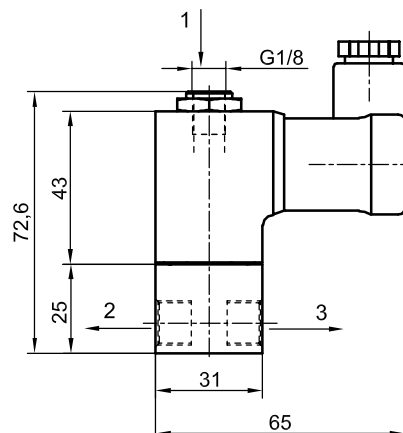
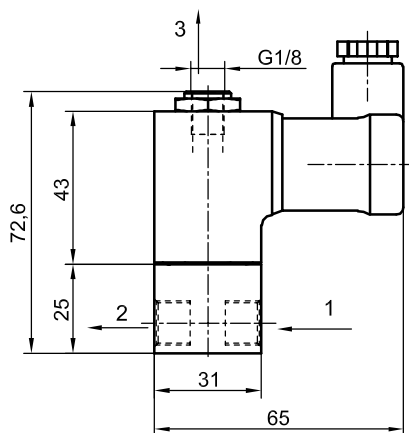
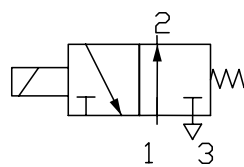
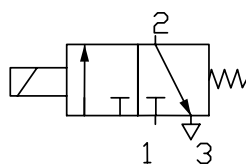



# CUT-OFF VALVE

electromagnetically operated, directly

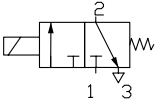
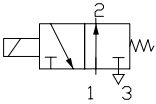

## ORDER NUMBERS

Connection thread	Graphical symbol	Position	Order number		
			24V DC voltage	230 V AC voltage	24V AC voltage
G1/4		Normally closed	50.5324.3214B	50.5324.3214J	50.5324.3214E
		Normally open	50.5316.3214NOB	50.5316.3214NOJ	50.5316.3214NOE

## ORDERING PROCEDURE

In your order, please specify the name of the valve, connection thread, control voltage, order number and number of pieces, e.g.:

**Cut-off valve 3/2 G1/4 electromagnetically operated, 230 V AC no. 50.5324.3214J 1 pc.**

## TECHNICAL SPECIFICATIONS

<b>Operating pressure range:</b>	0 — 10 bar
<b>Operating temperature range:</b>	0 to + 50°C*
<b>Medium:</b>	compressed air, filtered, lubricated or non-lubricated
<b>Control type:</b>	direct with additional manual control
<b>Flow direction:</b>	as per the diagram
<b>Nominal diameter:</b>	- for EVM valve - 1.8 mm - for MVB valve - 2.4 mm



Technical specifications	EVM type support valve	MVB type support valve
<b>Solenoid supply voltage</b>		
-direct current	12V, 24V +/- 10%, 48V, 110V	24V +/- 10%, 48V, 110V
-50 Hz alternating current	24V, 110V, 230V +/-10%	24V, 110V, 230V +/-10%
<b>Control voltage: designation "x" in the order number:</b>	direct current:	
	A - 12V	B - 24V
	50 Hz alternating current:	
	E - 24V	H - 110V      J - 230V
<b>DC power</b>	4.8 W - 6.5 W	10 W
<b>AC power</b>	7 VA - 8.5 VA	13.5 VA
<b>Electrical protection:</b>	IP 65	IP 65
<b>Relative solenoid control time</b>	100%	100%
<b>Electrical connector gland</b>	Pg 9	Pg 9
<b>Electric cable diameter</b>	Ø 6-8 mm	Ø 6-8 mm
<b>Response time</b>	6-18 ms	6-18 ms
<b>ORDER NUMBERS</b>	<b>22.0502.32x</b>	<b>22.0508.32x</b>

NOTE: the offer includes coils with ATEX certificate for group II category 3 (zone 2 or 22)  
Plugs with a TVS diode are available upon request.

## ORDERING PROCEDURE

In your order, please specify the name of the valve, control voltage, order number and number of pieces, e.g.:

**Electromagnetically operated EVM support valve, 230 V AC no. 22.0502.32J 1 pc.**

\* Using solenoid valves in relative humidity conditions up to 85% is recommended

# EVM AND MVB TYPE SUPPORT VALVES

for electromagnetically operated distribution valves



## EVM type support valve 3/2

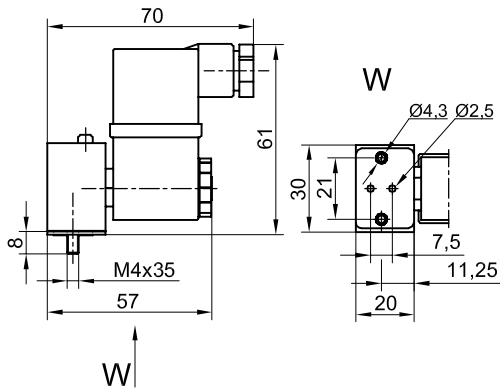
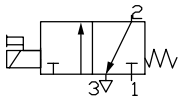

## MVB type support valve 3/2

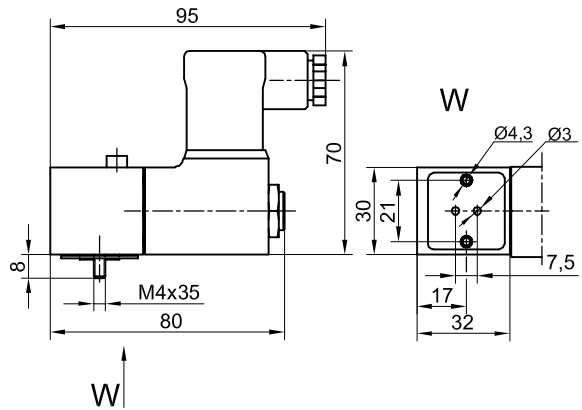
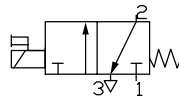

## Solenoid operator for EVM type support valve

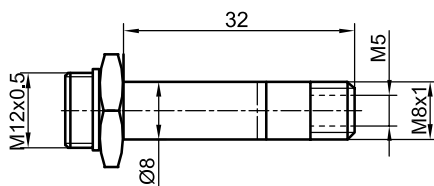

## Solenoid operator for MVB type support valve

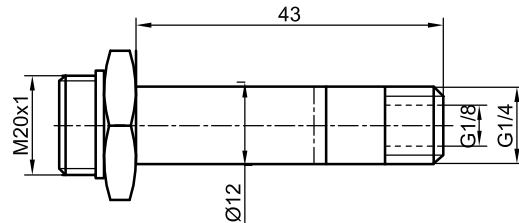

## Subplate G1/8 for EVM and MVB support valves

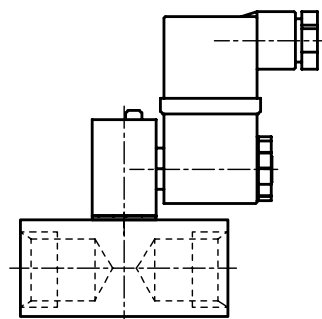
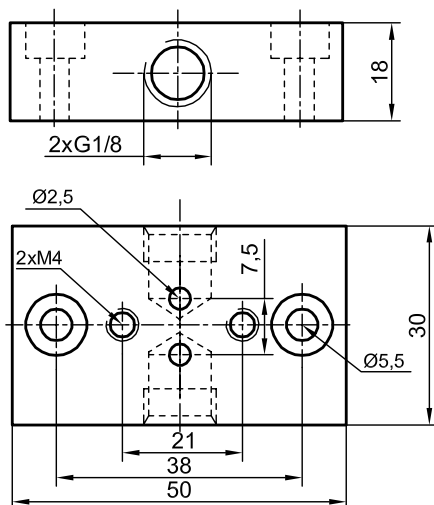

The subplate is used to mount the EVM and MVB support valves. In this case, a 3/2 G1/8 distribution valve can be obtained which is directly operated by the solenoid.

**SUBPLATE ORDER NUMBER: 25.0125.18**

## TECHNICAL SPECIFICATIONS

<b>Operating pressure range:</b>	0 — 10 bar
<b>Operating temperature range:</b>	0 to + 50°C*
<b>Medium:</b>	compressed air, filtered, lubricated or non-lubricated
<b>Control type:</b>	direct control with additional manual control
<b>Flow direction:</b>	as per the diagram



Technical specifications	AMISCO type support valve		
<b>Solenoid supply voltage</b>			
-direct current	12V, 24V +/- 10%,		
-50 Hz alternating current	24V, 110V, 230V +/-10%		
<b>Control voltage:</b> designation "x" in the order number:	direct current:		
	<b>A</b> - 12V	<b>B</b> - 24V	
<b>DC power</b>	50 Hz alternating current:		
	<b>E</b> - 24 V	<b>H</b> - 110V	<b>J</b> - 230 V
	1W - 2.5W		
<b>AC power</b>	3 VA		
<b>Electrical protection:</b>	IP 65		
<b>Relative solenoid control time</b>	100%		
<b>Electrical connector gland</b>	Pg 9		
<b>Electric cable diameter</b>	Ø 0,8–1,5 mm		
<b>Response time</b>	5–15 ms		
<b>ORDER NUMBERS</b>	<b>22.0517x</b>		

## Support valve AMISCO 3/2

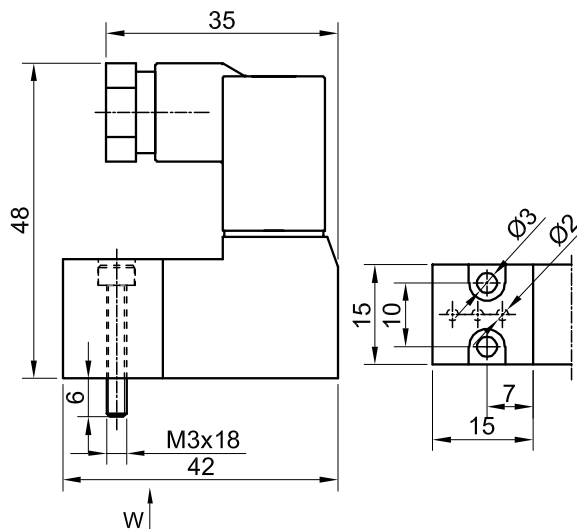

\* Using solenoid valves in relative humidity conditions up to 85% is recommended



## TECHNICAL SPECIFICATIONS

<b>Operating pressure range:</b>	according to the table
<b>Operating temperature range:</b>	0 to + 50°C
<b>Medium:</b>	compressed air, filtered, lubricated or non-lubricated
<b>Control voltage designation "x" in the order number:</b>	direct current: A - 12V B - 24 V 50 Hz alternating current: E - 24 V H - 110 V J - 230 V
<b>Solenoid supply voltage:</b>	DC 12V, 24V +/-10% AC 24 V, 110 V, 230 V +/- 10%
<b>Power consumption for the direct current:</b>	4.8–6.5W
<b>Power consumption for the alternating current:</b>	7–8.5VA
<b>Electrical protection:</b>	IP 65
<b>Construction materials:</b>	<b>Body</b> - aluminium alloy <b>Covers</b> - plastic <b>Slider</b> - stainless steel <b>Seals</b> - polyurethane PU



Number of paths / valve positions	Graphical symbol	Control type and operating pressure range	Connection thread	Nominal diameter	Order number
3/2		electromagnetic 1.5 — 10 bar	G1/8	Ø 5	<b>22.0701.3218x</b>
			G1/4	Ø 6	<b>22.0701.3214x</b>
		electromagnetic, pressure and spring return normally closed 3.0 — 10 bar	G1/8	Ø 5	<b>22.0703.3218x</b>
			G1/4	Ø 6	<b>22.0703.3214x</b>
5/2		electromagnetic 1.5 — 10 bar	G1/8	Ø 5	<b>22.0701.5218x</b>
			G1/4	Ø 6	<b>22.0701.5214x</b>
		electromagnetic single-side, own pressure and spring return 3.0 — 10 bar	G1/8	Ø 5	<b>22.0703.5218x</b>
			G1/4	Ø 6	<b>22.0703.5214x</b>
5/3		electromagnetic, in the middle position all paths cut off 3.0 — 10 bar	G1/8	Ø 5	<b>22.0709.5318x</b>
			G1/4	Ø 6	<b>22.0709.5314x</b>
		electromagnetic, in the middle position all paths vented 3.0 — 10 bar	G1/8	Ø 5	<b>22.0710.5318x</b>
			G1/4	Ø 6	<b>22.0710.5314x</b>
		electromagnetic, in the middle position all paths connected with the supply 3.0 — 10 bar	G1/8	Ø 5	<b>22.0711.5318x</b>
			G1/4	Ø 6	<b>22.0711.5314x</b>

## ORDERING PROCEDURE

In your order, please specify: name, number of paths / positions, connection thread, order number and number of pieces. In the place designated with "x", enter the letter code of the control voltage, e.g.

**Distribution valve ZMG 5/2 G1/8 electromagnetically operated, pressure and spring return 230 V AC no. 22.0703.5218J 1 pc.**

# ZMG SERIES

Compact electromagnetically operated distribution valves



## VALVE ZMG 3/2 G1/8

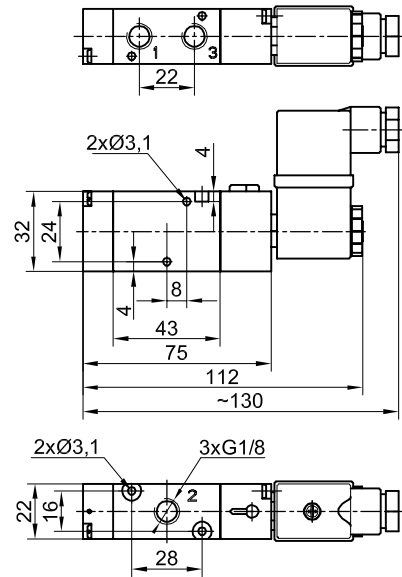
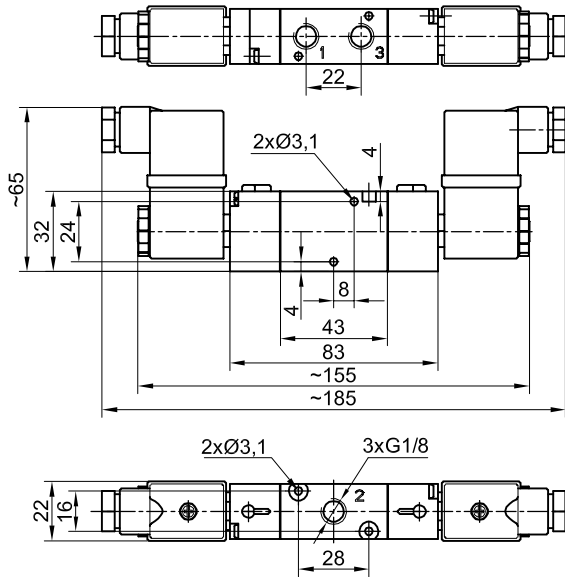
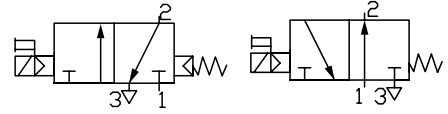
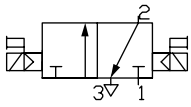

## VALVE ZMG 3/2 G1/4

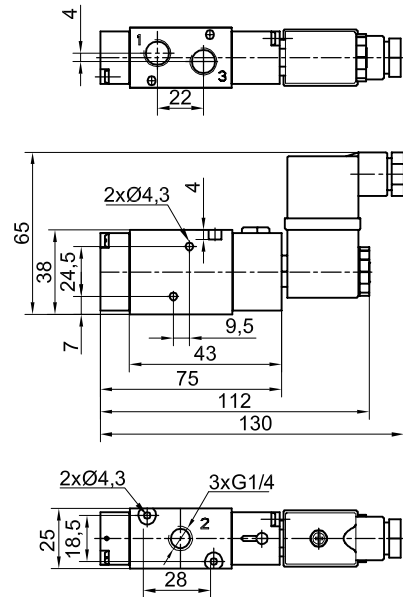
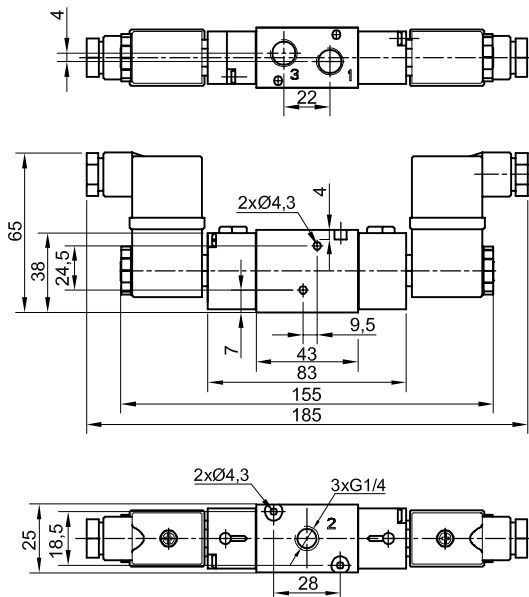
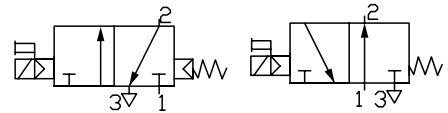
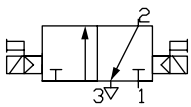

## VALVE ZMG 5/2 G1/8

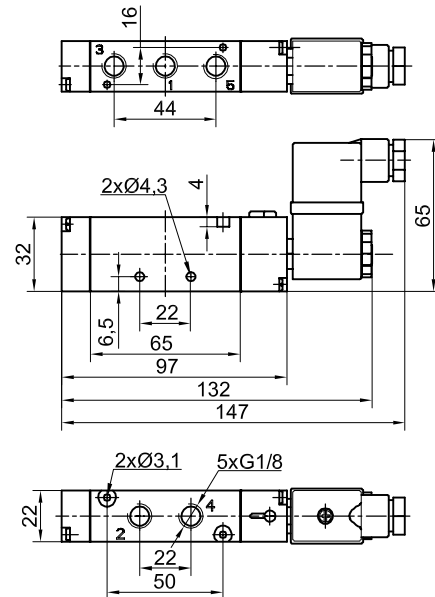
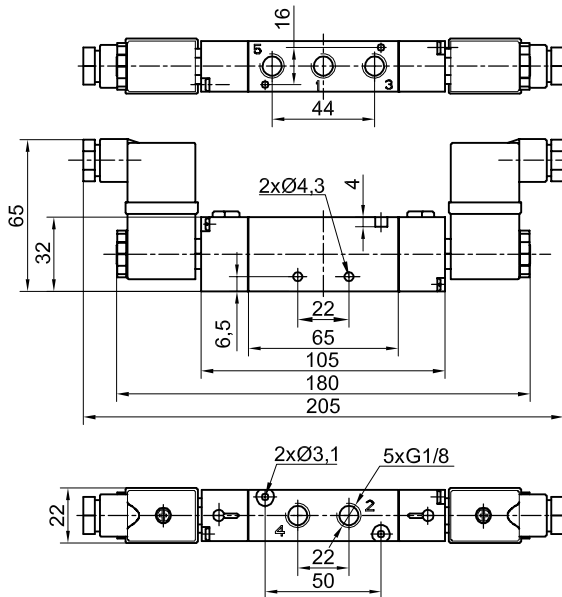
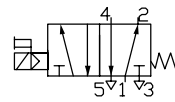
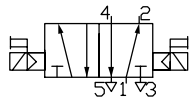

## VALVE ZMG 5/2 G1/4

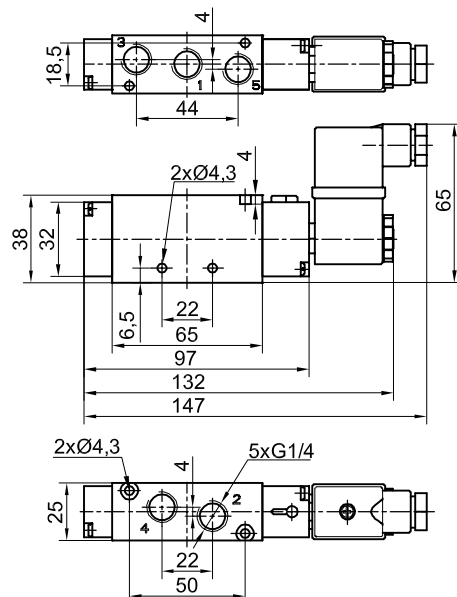
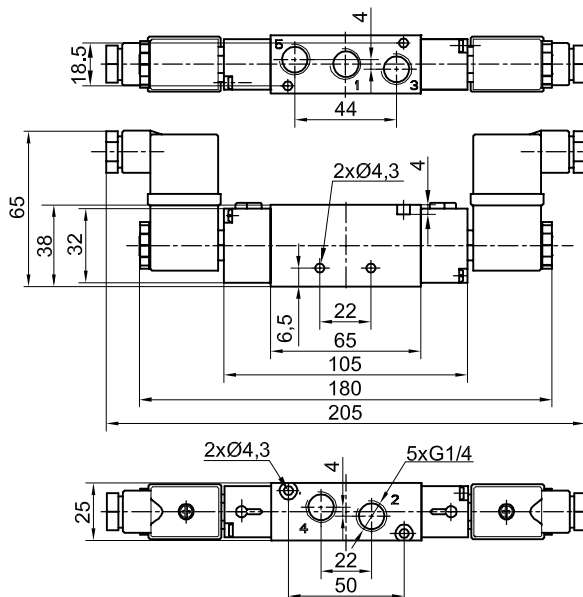
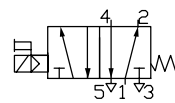
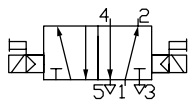



# ZMG SERIES

Compact electromagnetically operated  
distribution valves



## VALVE ZMG 5/3 G1/8

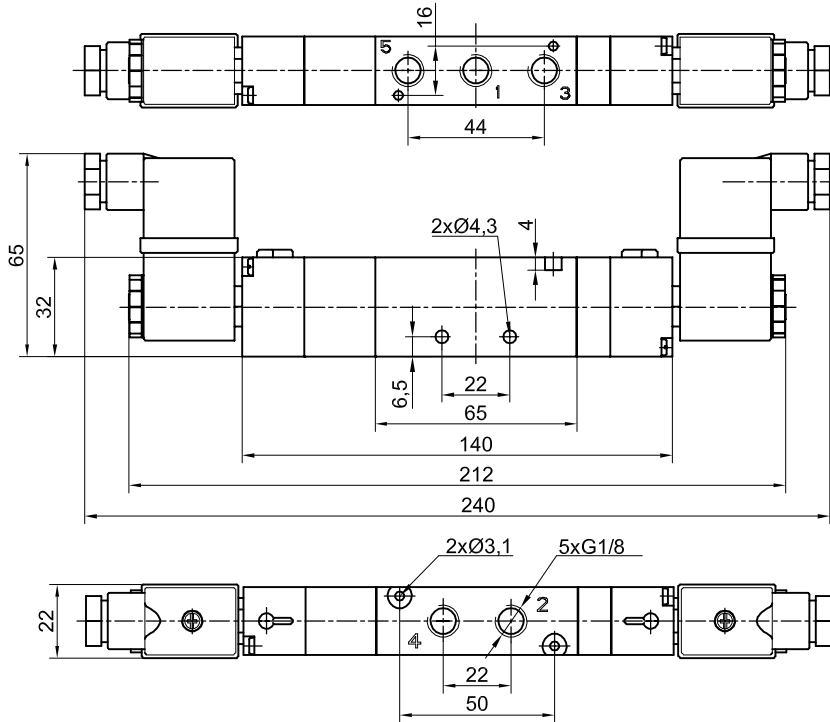
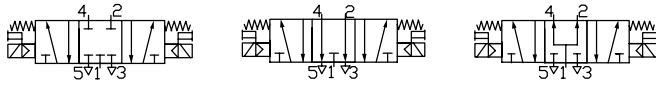

## VALVE ZMG 5/3 G1/4

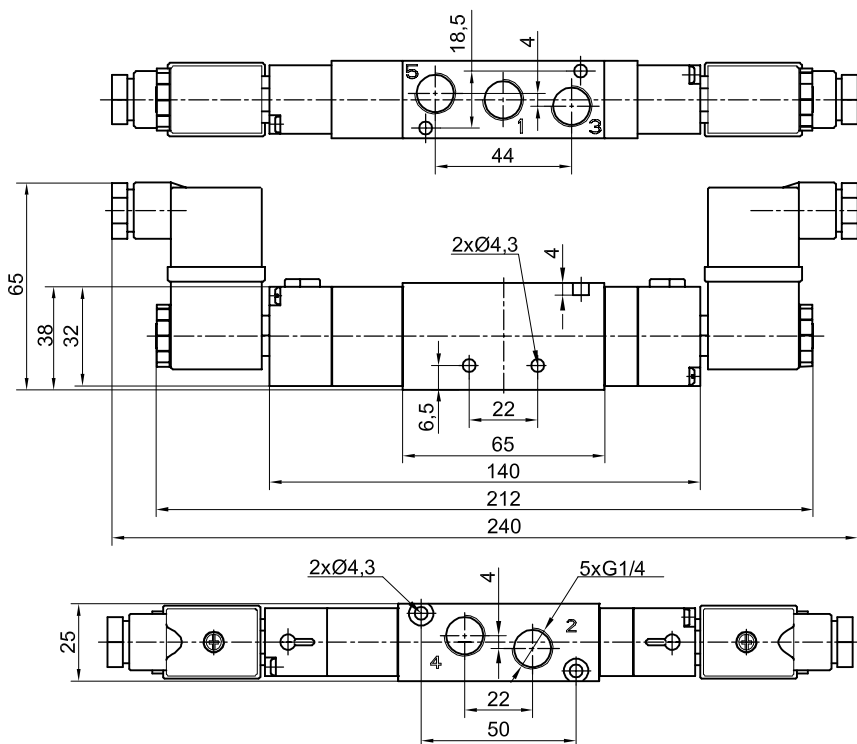
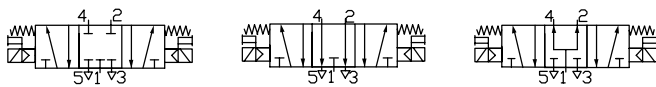

## TECHNICAL SPECIFICATIONS

<b>Operating pressure range:</b>	according to the table
<b>Operating temperature range:</b>	0 to + 50°C
<b>Medium:</b>	compressed air, filtered, lubricated or non-lubricated
<b>Control voltage</b>	direct current: <b>A</b> - 12V <b>B</b> - 24V
<b>designation "x" in the order number:</b>	50 Hz alternating current: <b>E</b> - 24V <b>H</b> - 110V <b>J</b> - 230V
<b>Solenoid supply voltage:</b>	DC 12V, 24V +/-10% AC 24 V, 110 V, 230 V / 50 Hz +/- 10%
<b>Power consumption for the direct current:</b>	4.8–6.5W
<b>Power consumption for the alternating current:</b>	7–8.5VA
<b>Electrical protection:</b>	IP 65
<b>Construction materials:</b>	<p><b>Body</b> - aluminium alloy</p> <p><b>Covers</b> - plastic</p> <p><b>Slider</b> - stainless steel</p> <p><b>Seals</b> - polyurethane PU</p>



Number of paths / valve positions	Graphical symbol	Control type and operating pressure range	Con- nection thread	Nominal diameter	Order number		
3/2		electromagnetic, pressure and spring return normally closed 3.0 — 10 bar	G1/4	Ø 6	<b>22.0403.3214x</b>		
		electromagnetic, pressure and spring return normally open 3.0 — 10 bar			<b>22.0403.3214NOx</b>		
5/2		electromagnetic 1.5 — 7.0 bar					<b>22.0401.5214x</b>
		electromagnetic, own pressure and spring return 3.0 — 7.0 bar					<b>22.0403.5214x</b>

## ORDERING PROCEDURE

In your order, please specify: name, number of paths / positions, connection thread, order number and number of pieces. In the place designated with "x", enter the letter code of the control voltage, e.g.

**Distribution valve ZMG 5/2 G1/4 electromagnetically operated,  
own pressure and spring return, with NAMUR type connection, 230 V AC 50Hz no. 22.0403.5214J 1 pc.**

# ZMG NAMUR SERIES

Compact distribution valves

electromagnetically operated with NAMUR connection



## VALVE ZMG 3/2 G1/4 WITH NAMUR CONNECTION

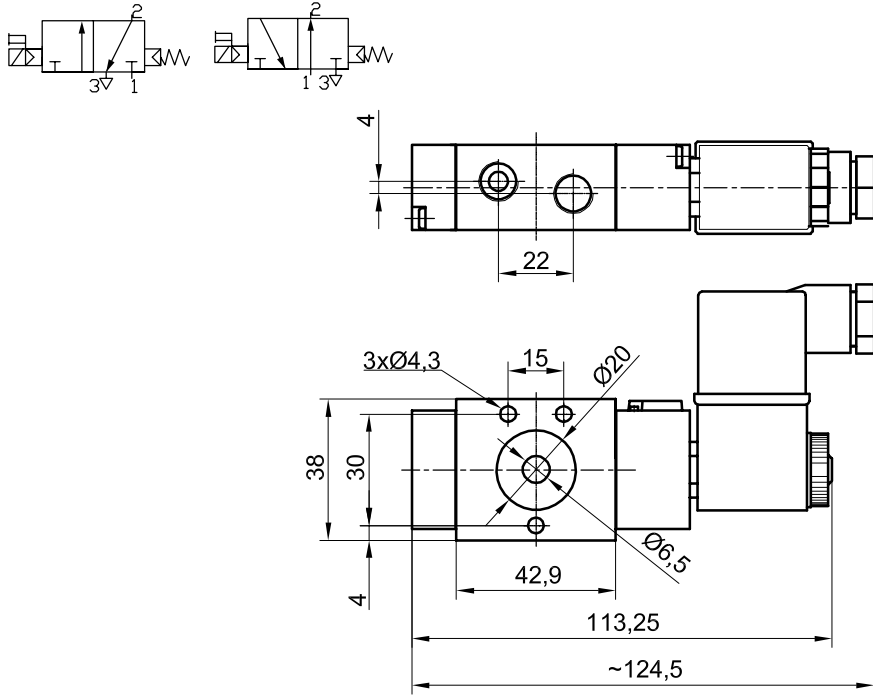

## VALVE ZMG 5/2 G1/4 WITH NAMUR CONNECTION

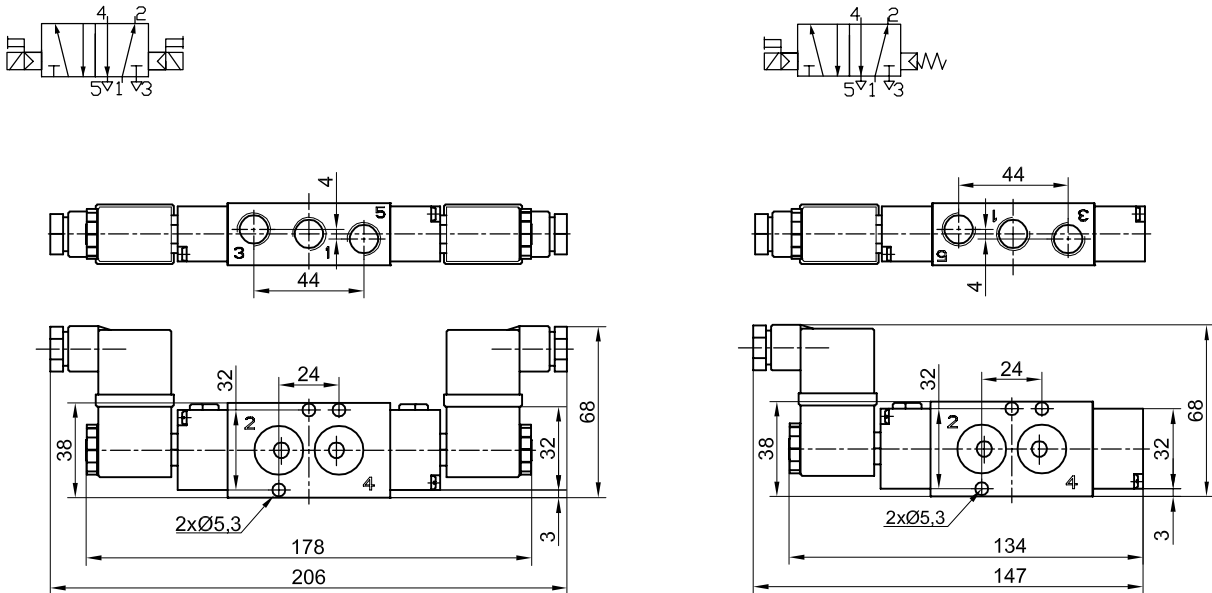

### TECHNICAL SPECIFICATIONS

<b>Operating pressure range:</b>	according to the table
<b>Operating temperature range:</b>	0 to + 50°C
<b>Medium:</b>	compressed air, filtered, lubricated or non-lubricated
<b>Control voltage designation "x" in the order number:</b>	direct current: B - 24 V 50 Hz alternating current: E - 24 V    H - 110 V    J - 230 V
<b>Solenoid supply voltage:</b>	DC 24V +/-10% AC 24 V, 110 V, 230 V +/- 10%
<b>Power consumption for the direct current:</b>	2.5W
<b>Power consumption for the alternating current:</b>	3VA
<b>Electrical protection:</b>	IP 65
<b>Construction materials:</b>	
<b>Body, covers, slider</b>	- aluminium alloy
<b>Seals</b>	- polyurethane PU



Number of paths / valve positions	Graphical symbol	Type of control and operating pressure range	Connection thread	Nominal diameter	Order number
3/2		electromagnetic 1.5 — 10 bar	G1/8	Ø 5	<b>22.1701.3218x</b>
			G1/4	Ø 9	<b>22.1701.3214x</b>
		electromagnetic single-side, spring return 2.5 — 10 bar	G1/8	Ø 5	<b>22.1703.3218x</b>
			G1/4	Ø 9	<b>22.1703.3214x</b>
		electromagnetic single-side, spring return normally open 2.5 — 10 bar	G1/8	Ø 5	<b>22.1703.3218NOx</b>
			G1/4	Ø 9	<b>22.1703.3214NOx</b>
3/3		electromagnetic, in the middle position all paths cut off 2.5 — 10 bar	G1/4	Ø 9	<b>22.1709.3314x</b>
5/2		electromagnetic 1.5 — 10 bar	G1/8	Ø 5	<b>22.1701.5218x</b>
			G1/4	Ø 9	<b>22.1701.5214x</b>
		electromagnetic single-side, spring return 2.5 — 10 bar	G1/8	Ø 5	<b>22.1703.5218x</b>
			G1/4	Ø 9	<b>22.1703.5214x</b>
5/3		electromagnetic, in the middle position all paths cut off 2.5 — 10 bar	G1/8	Ø 5	<b>22.1709.5318x</b>
			G1/4	Ø 9	<b>22.1709.5314x</b>
		electromagnetic, in the middle position all paths vented 2.5 — 10 bar	G1/8	Ø 5	<b>22.1710.5318x</b>
			G1/4	Ø 9	<b>22.1710.5314x</b>
		electromagnetic, in the middle position all paths connected to the supply 2.5 — 10 bar	G1/8	Ø 5	<b>22.1711.5318x</b>
			G1/4	Ø 9	<b>22.1711.5314x</b>

### ORDERING PROCEDURE

In your order, please specify: name, number of paths / positions, connection thread, order number and number of pieces. In the place designated with "x", enter the letter code of the control voltage, e.g.

**Distribution valve ZEM 5/2 G1/4, electromagnetically operated, spring return,  
230 V AC no. 22.1703.5214J 1 pc.**

### VALVE ZEM 3/2 G1/8

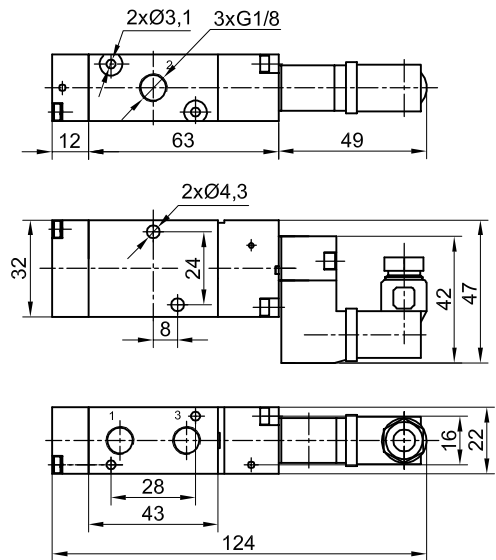
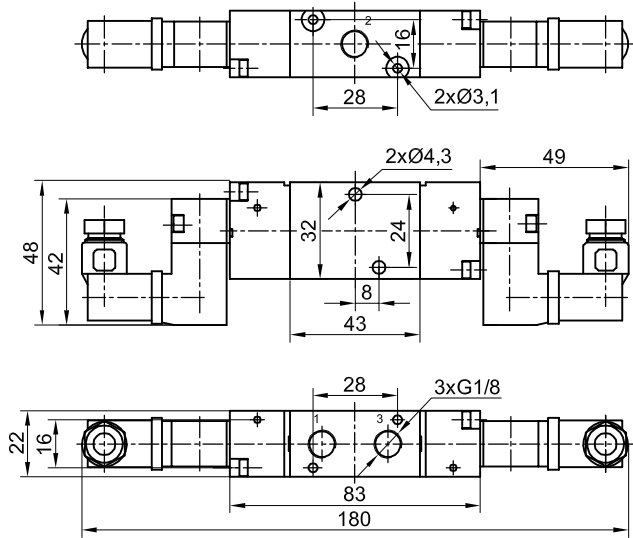
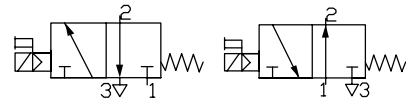
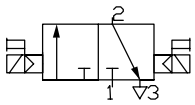

## VALVE ZEM 3/2 G1/4

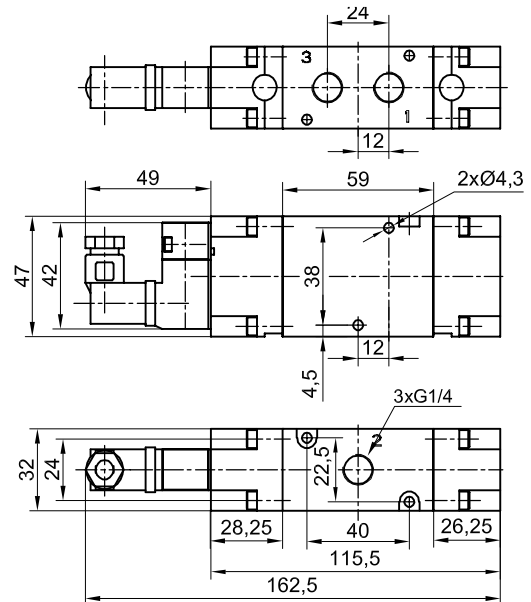
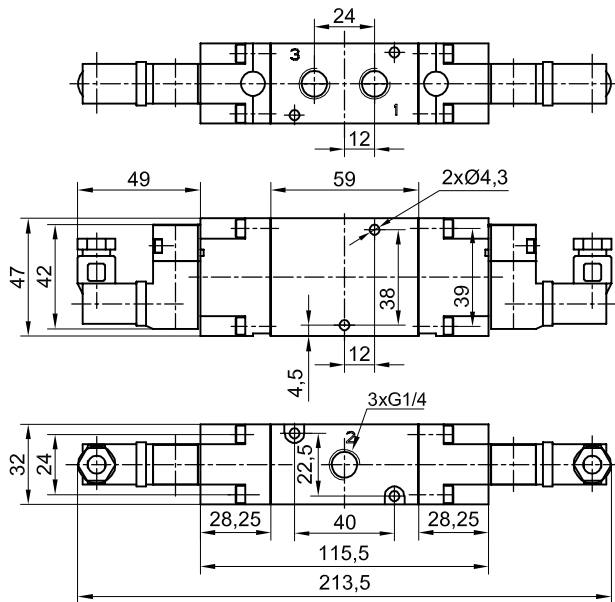
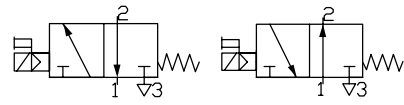
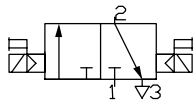

## VALVE ZEM 3/3 G1/4

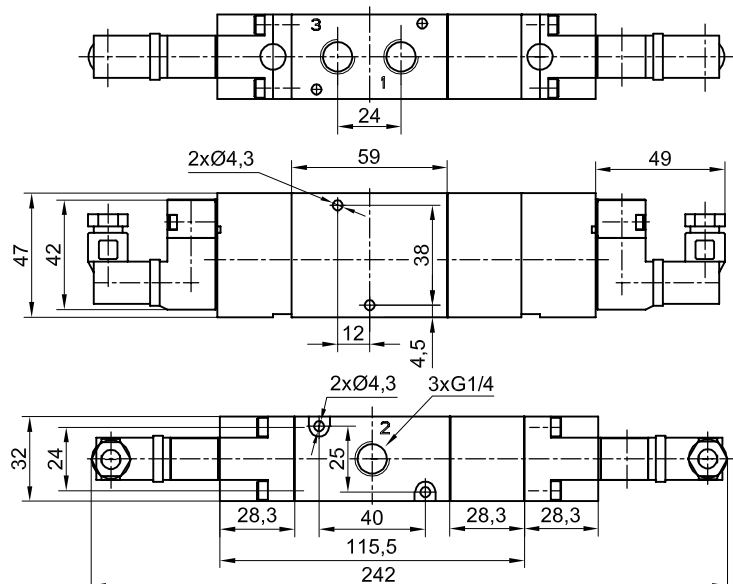
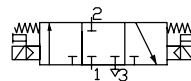

# ZEM SERIES

Electromagnetically operated distribution valves



## VALVE ZEM 5/2 G1/8

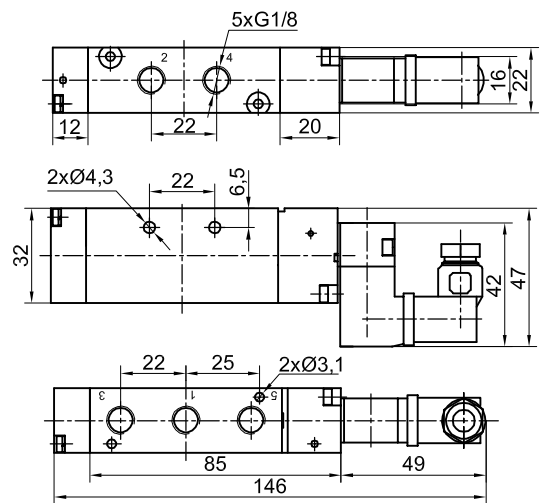
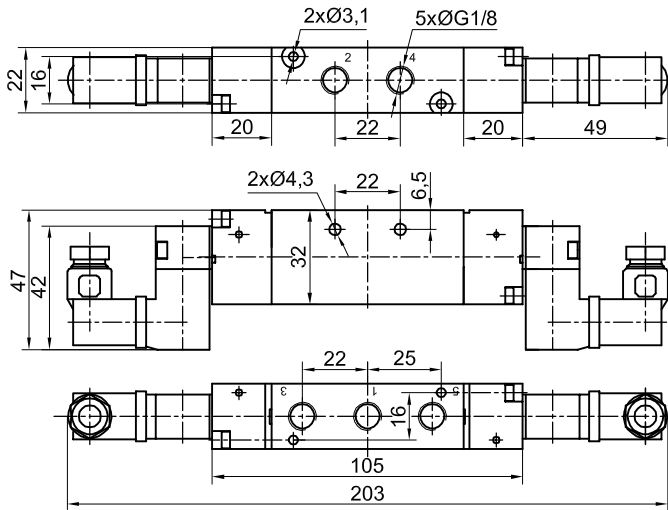
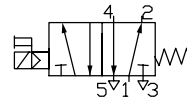
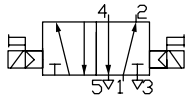

## VALVE ZEM 5/2 G1/4

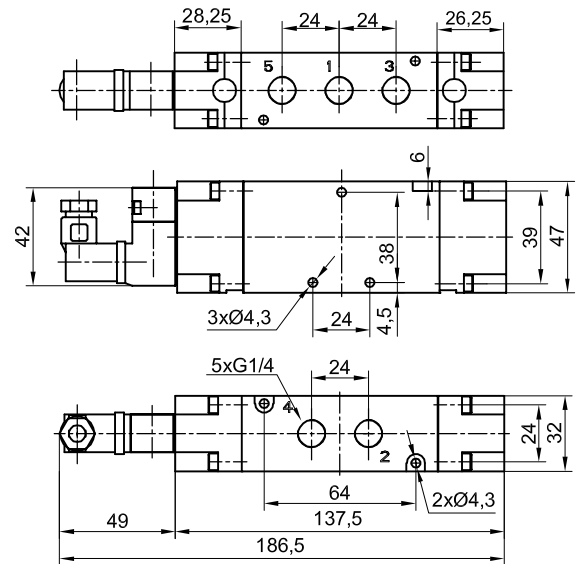
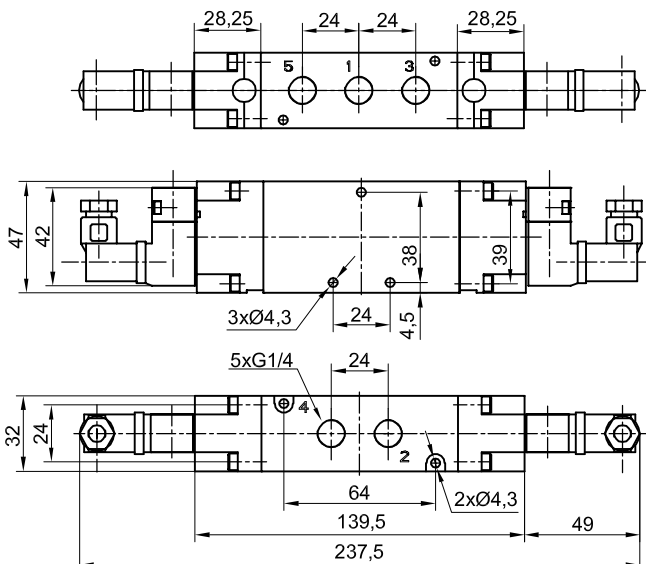
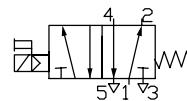
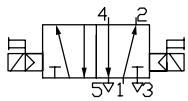

## VALVE ZEM 5/3 G1/8

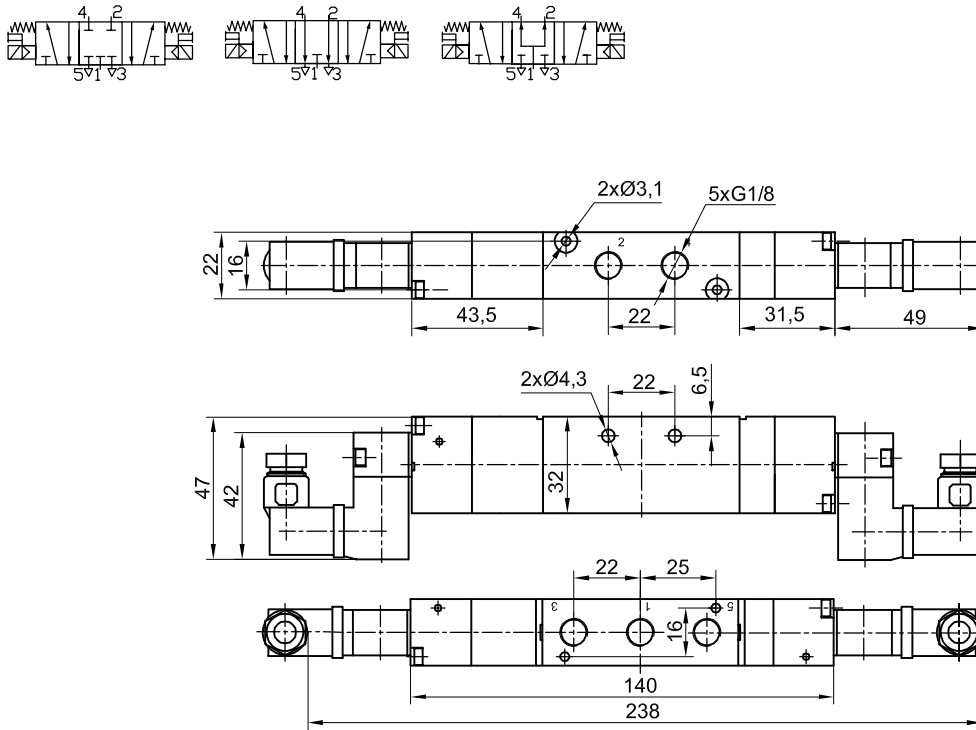

## VALVE ZEM 5/3 G1/4

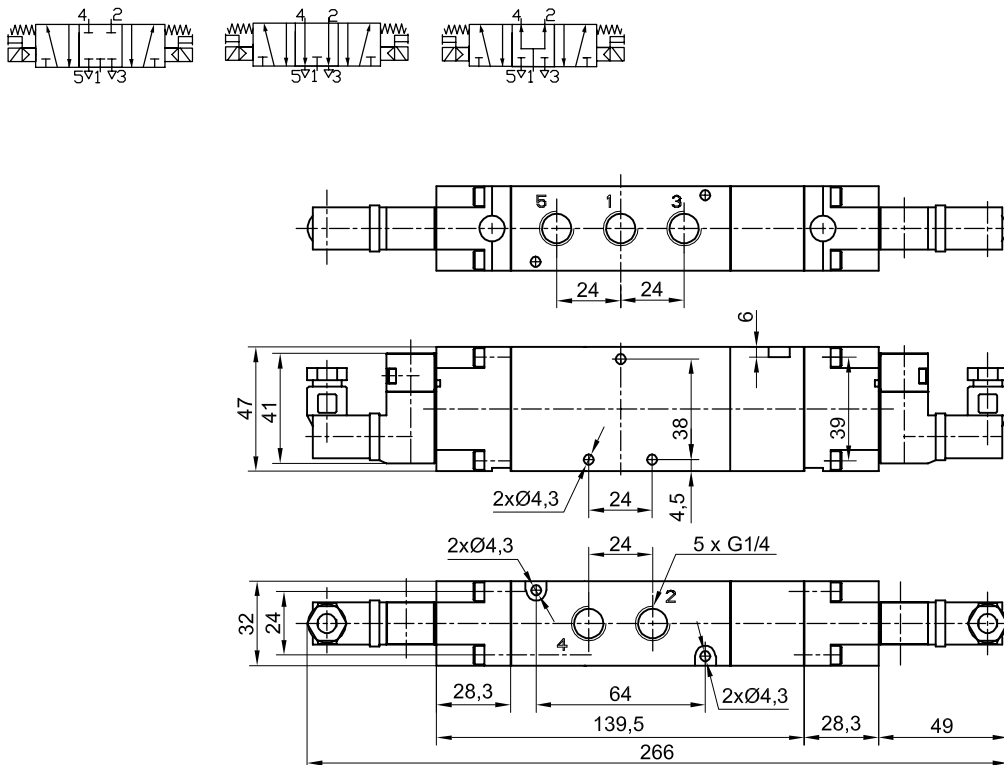





### TECHNICAL SPECIFICATIONS

<b>Operating pressure range:</b>	according to the table
<b>Operating temperature range:</b>	0 to + 50°C
<b>Medium:</b>	compressed air, filtered, lubricated or non-lubricated
<b>Control voltage designation "x" in the order number:</b>	direct current: B - 24 V 50 Hz alternating current: E - 24 V    H - 110 V    J - 230 V
<b>Solenoid supply voltage:</b>	DC 24V +/-10% AC 24 V, 110 V, 230 V +/- 10%
<b>Power consumption for the direct current:</b>	2.5W
<b>Power consumption for the alternating current:</b>	3VA
<b>Electrical protection:</b>	IP 65
<b>Construction materials:</b>	
<b>Body, covers, slider</b>	- aluminium alloy
<b>Seals</b>	- polyurethane PU



Number of paths / valve positions	Graphical symbol	Control type and operating pressure range	Connection thread	Nominal diameter [mm]	Order number
5/2		electromagnetic 1.5 — 10 bar	G1/4	Ø 9	<b>22.1401.5214x</b>
		electromagnetic single-side, spring return 2,5– 10 bar			<b>22.1403.5214x</b>
5/3		electromagnetic, in the middle position all paths cut off 2,5– 10 bar			<b>22.1409.5314x</b>
		electromagnetic, in the middle position all paths vented 2,5– 10 bar			<b>22.1410.5314x</b>
		electromagnetic, in the middle position all paths connected with the supply 2,5– 10 bar			<b>22.1411.5314x</b>

### ORDERING PROCEDURE

In your order, please specify: name, number of paths / positions, connection thread, order number and number of pieces. In the place designated with "x", enter the letter code of the control voltage, e.g.

**Distribution valve ZEM 5/2 G1/4, electromagnetically operated, spring return, 230 V AC NAMUR no. 22.1403.5214J 1 pc.**

# ZEM SERIES

Electromagnetically operated distribution valves  
with NAMUR connection



## VALVE ZEM 5/2 G1/4

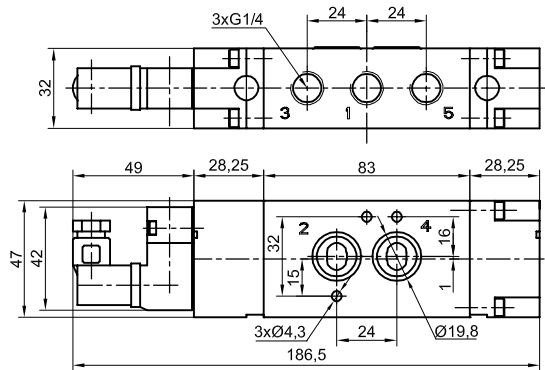
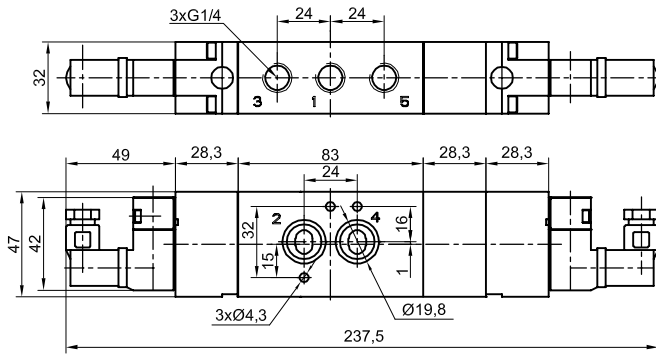
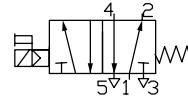
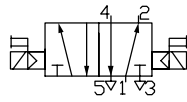

## VALVE ZEM 5/3 G1/4

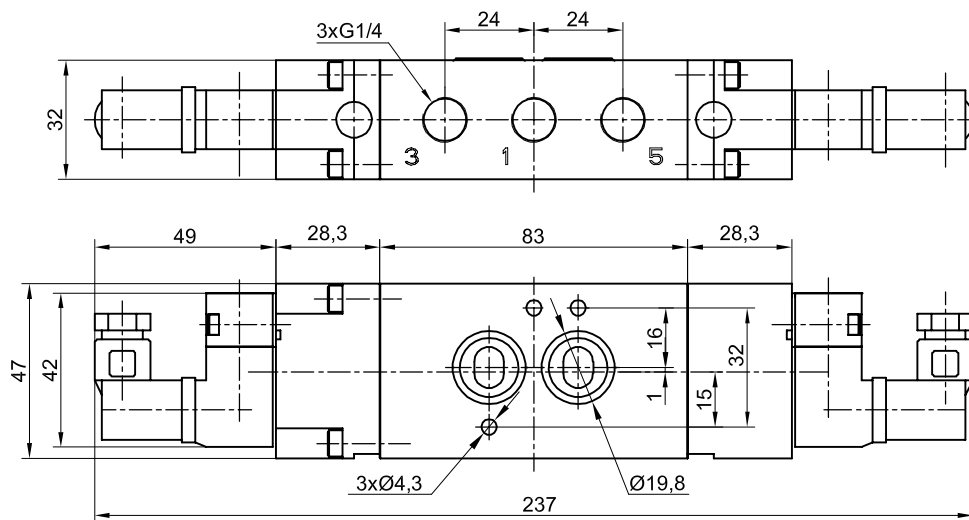
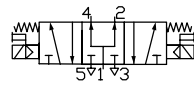
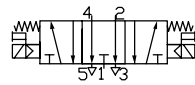
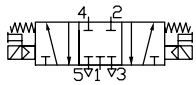

### TECHNICAL SPECIFICATIONS

<b>Operating pressure range:</b>	according to the table
<b>Operating temperature range:</b>	0 to + 50°C
<b>Medium:</b>	compressed air, filtered, lubricated or non-lubricated
<b>Control voltage</b>	<b>A</b> - 12V <b>B</b> - 24 V
<b>designation "x" in the order number:</b>	50 Hz alternating current: <b>E</b> - 24 V <b>H</b> - 110 V <b>J</b> - 230 V
<b>Solenoid supply voltage:</b>	DC 12V, 24V +/-10% AC 24 V, 110 V, 230 V +/- 10%
<b>Power consumption for the direct current:</b>	4.8–6.5W
<b>Power consumption for the alternating current:</b>	7–8.5VA
<b>Electrical protection:</b>	IP 65
<b>Construction materials:</b>	<p><b>Body</b> - aluminium alloy</p> <p><b>Covers</b> - plastic</p> <p><b>Slider</b> - aluminium alloy</p> <p><b>Seals</b> - polyurethane PU</p>



Number of paths / valve positions	Graphical symbol	Control type and operating pressure range	Connection thread	Nominal diameter	Order number
3/2		electromagnetic 1.5 — 10 bar	G3/8	Ø 11	<b>22.0801.3238x</b>
		electromagnetic and with external pressure* 0 — 10 bar			<b>22.0802.3238x</b>
		electromagnetic single-side, spring return, NORMALLY CLOSED 3.0 — 10 bar			<b>22.0803.3238x</b>
		electromagnetic single-side, spring return, NORMALLY OPEN 3.0 — 10 bar			<b>22.0803.3238NOx</b>
		electromagnetic single-side and with external pressure, spring return, NORMALLY CLOSED** 0 — 10 bar			<b>22.0804.3238x</b>
		electromagnetic, own pressure return (differential piston) 1.5 — 10 bar			<b>22.0805.3238x</b>
3/3		electromagnetic, in the middle position all paths cut off 3.0 — 10 bar			<b>22.0809.3338x</b>

\*control pressure range 1.5 – 10 bar

\*\*control pressure range 3.0 – 10 bar

# ZE SERIES

## Electromagnetically operated distribution valves



Number of paths / valve positions	Graphical symbol	Control type and operating pressure range	Connection thread	Nominal diameter	Order number
5/2		electromagnetic 1.5 — 10 bar	G3/8	Ø 11	<b>22.0801.5238x</b>
		electromagnetic and with external pressure* 0 — 10 bar			<b>22.0802.5238x</b>
		electromagnetic single-side, spring return 3.0 — 10 bar			<b>22.0803.5238x</b>
		electromagnetic single-side and with external pressure, spring return** 0 — 10 bar			<b>22.0804.5238x</b>
		electromagnetic single-side, own pressure return (differential piston) 1.5 — 10 bar			<b>22.0805.5238x</b>
		electromagnetic single-side and external pressure, own pressure return (differential piston)* 1.5 — 10 bar			<b>22.0806.5238x</b>
		electromagnetic single-side, external pressure return* 1.5 — 10 bar			<b>22.0807.5238x</b>
		electromagnetic single-side and with external pressure, external pressure return* 0 — 10 bar			<b>22.0808.5238x</b>
5/3		electromagnetic, in the middle position all paths cut off 3.0 — 10 bar			<b>22.0809.5338x</b>
		electromagnetic, in the middle position all paths vented 3.0 — 10 bar			<b>22.0810.5338x</b>
		electromagnetic, in the middle position connected with supply 3.0 — 10 bar			<b>22.0811.5338x</b>

### ORDERING PROCEDURE

In your order, please specify: name, number of paths / positions, connection thread, order number and number of pieces. In the place designated with "x", enter the letter code of the control voltage, e.g.

**Distribution valve ZE 5/2 G3/8 single-side electromagnetically operated,  
spring return 230 V AC no. 22.0803.5238J 1 pc.**

\*control pressure range 1.5 – 10 bar

\*\*control pressure range 3.0 – 10 bar

### VALVE ZE 3/2 G3/8

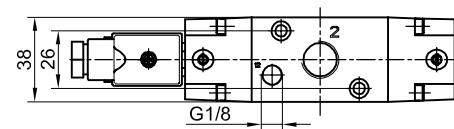
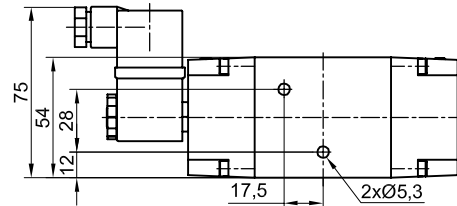
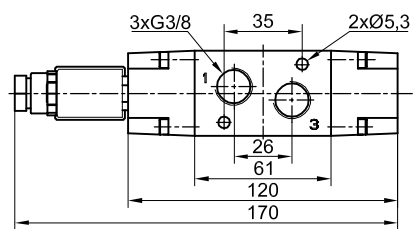
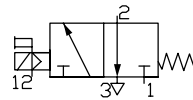
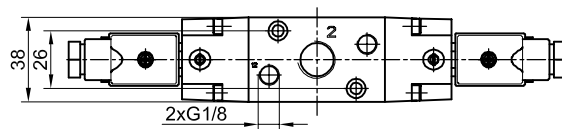
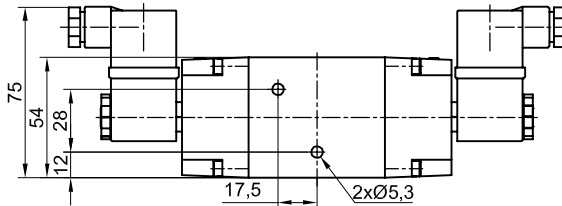
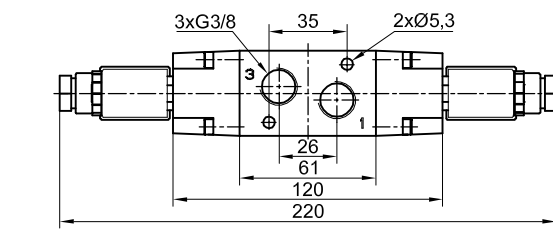
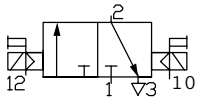
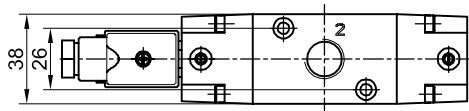
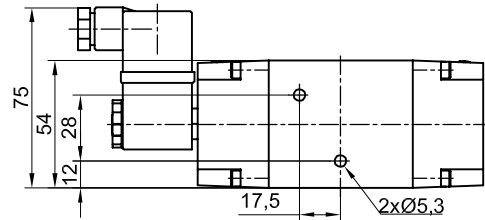
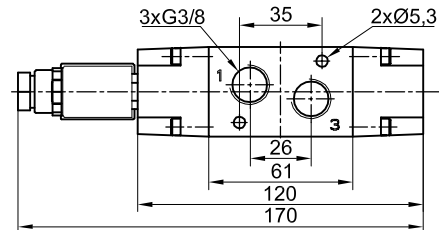
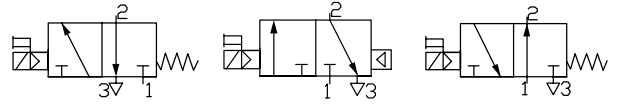
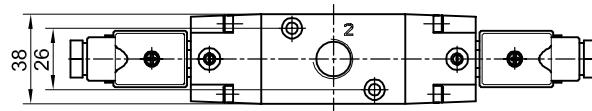
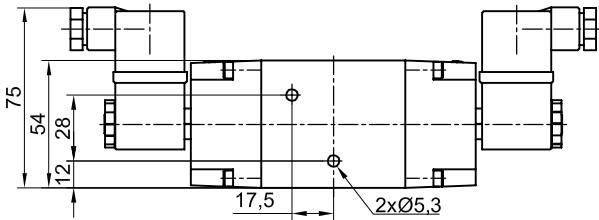
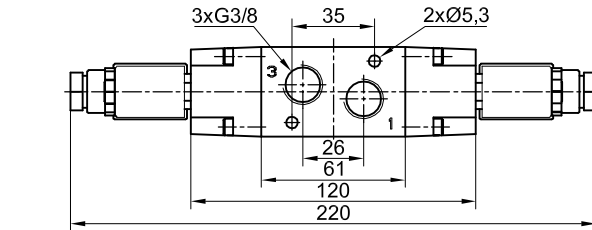
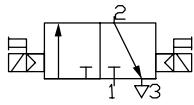

**Note:** in ZE distribution valves, the external supply to the support valve is supplied to threaded connections marked 12 and 14 or 12 and 10.

# ZE SERIES

## Electromagnetically operated distribution valves



### VALVE ZE 3/3 G3/8

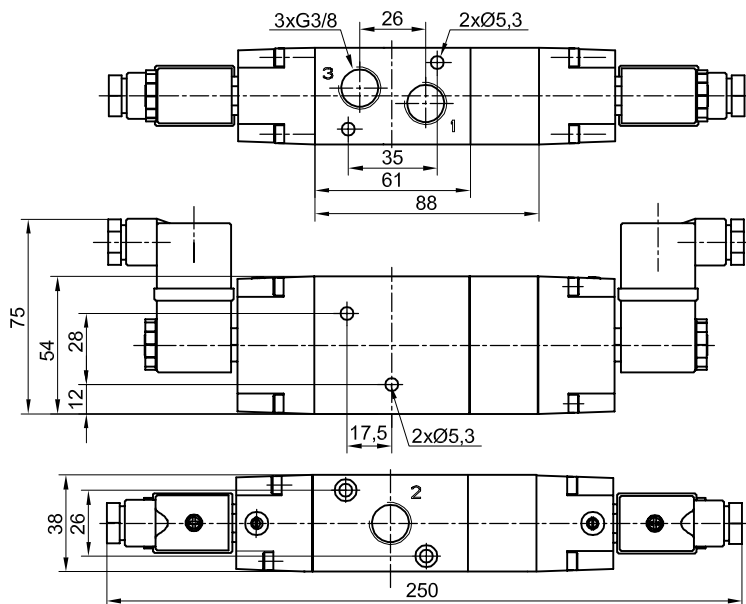
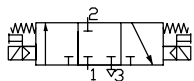

### VALVE ZE 5/2 G3/8

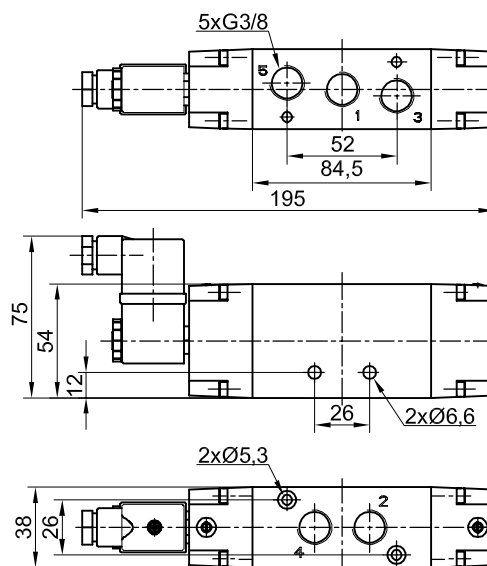
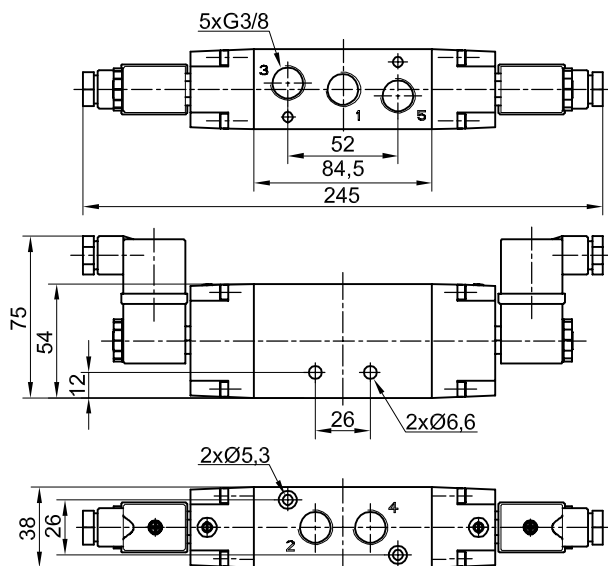
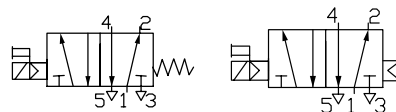
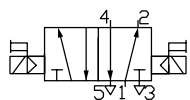

### VALVE ZE 5/2 G3/8

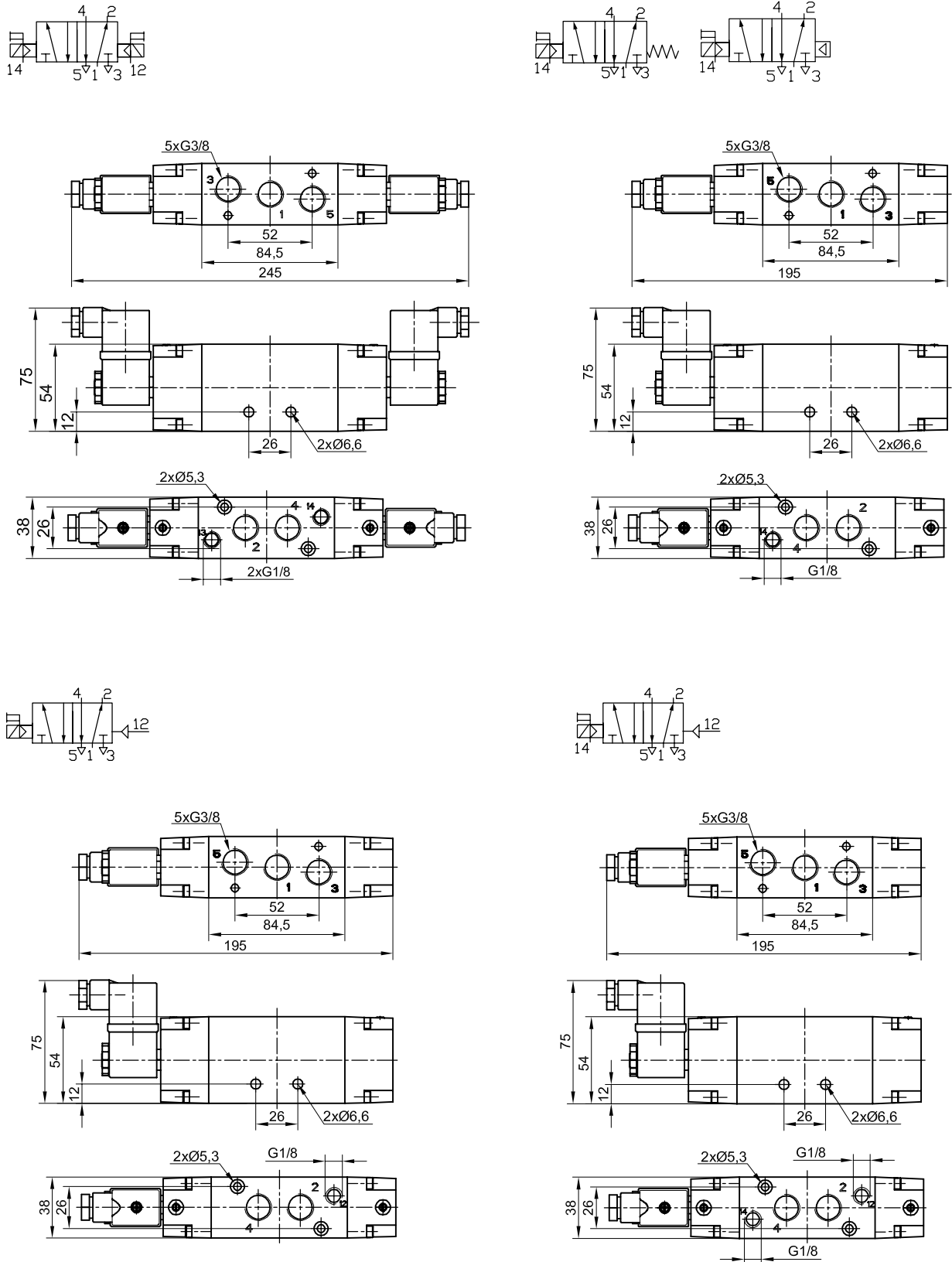

**Note:** in ZE distribution valves, the external supply to the support valve is supplied to threaded connections marked 12 and 14 or 12 and 10.



# ZE SERIES

## Electromagnetically operated distribution valves



### VALVE ZE 5/3 G3/8

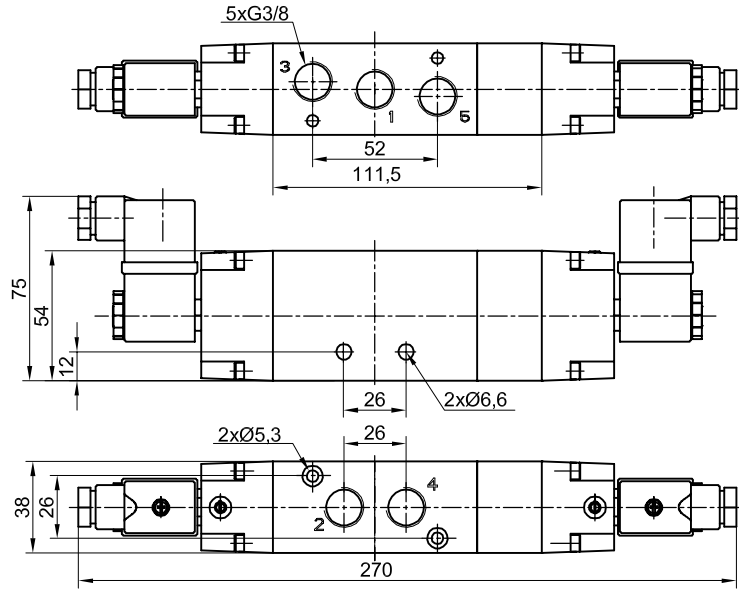
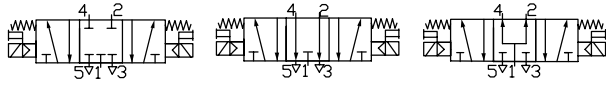

4

### TECHNICAL SPECIFICATIONS

<b>Operating pressure range:</b>	according to the table
<b>Operating temperature range:</b>	0 to + 50°C
<b>Medium:</b>	compressed air, filtered, lubricated or non-lubricated
<b>Control voltage designation "x" in the order number:</b>	direct current: A - 12V B - 24V 50 Hz alternating current: E - 24V H - 110V J - 230V
<b>Solenoid supply voltage:</b>	DC 12V, 24V +/-10% AC 24V, 110V, 230V +/- 10%
<b>Power consumption for the direct current:</b>	4.8-6.5W
<b>Power consumption for the alternating current:</b>	7-8.5VA
<b>Electrical protection:</b>	IP 65
<b>Construction materials:</b>	
<b>Body, covers, slider</b>	- aluminium alloy
<b>Seals</b>	- polyurethane PU



Number of paths / valve positions	Graphical symbol	Control type and operating pressure range	Connection thread	Nominal diameter	Order number
3/2		electromagnetic 1.5 — 10 bar	G1/2	Ø 15	<b>22.1901.3212x</b>
		electromagnetic and with external pressure* 0 — 10 bar			<b>22.1902.3212x</b>
		electromagnetic single-side, spring return, NORMALLY CLOSED 3.0 — 10 bar			<b>22.1903.3212x</b>
		electromagnetic single-side, spring return, NORMALLY OPEN 3.0 — 10 bar			<b>22.1903.3212NOx</b>
		electromagnetic single-side and with external pressure, spring return, NORMALLY CLOSED** 0 — 10 bar			<b>22.1904.3212x</b>
		electromagnetic single-side and with external pressure, spring return, NORMALLY OPEN** 0 — 10 bar			<b>22.1904.3212NOx</b>
5/2		electromagnetic 1.5 — 10 bar	G1/2	Ø 15	<b>22.1901.5212x</b>
		electromagnetic and with external pressure* 0 — 10 bar			<b>22.1902.5212x</b>
		electromagnetic single-side, spring return 3.0 — 10 bar			<b>22.1903.5212x</b>
		electromagnetic single-side and with external pressure, spring return** 0 — 10 bar			<b>22.1904.5212x</b>

\*control pressure range 1.5 – 10 bar

\*\*control pressure range 3.0 – 10 bar

# ZDE SERIES

Distribution valves

electromagnetically operated - wired supply



Number of paths / valve positions	Graphical symbol	Control type and operating pressure range	Connection thread	Nominal diameter	Order number
5/3		electromagnetic, in the middle position all paths cut off 3.0 — 10 bar	G1/2	Ø 15	22.1909.5312x
		electromagnetic, in the middle position all paths vented 3.0 — 10 bar			22.1910.5312x
		electromagnetic, in the middle position all paths connected with the supply 3.0 — 10 bar			22.1911.5312x

## ORDERING PROCEDURE

In your order, please specify: name, number of paths / positions, connection thread, order number and number of pieces. In the place designated with "x", enter the letter code of the control voltage, e.g.

**Distribution valve ZDE 5/2 G1/2 single-side electromagnetically operated, spring return, 230 V AC 50 Hz no. 22.1903.5212J 1 pc.**

## VALVE ZDE 3/2 G1/2

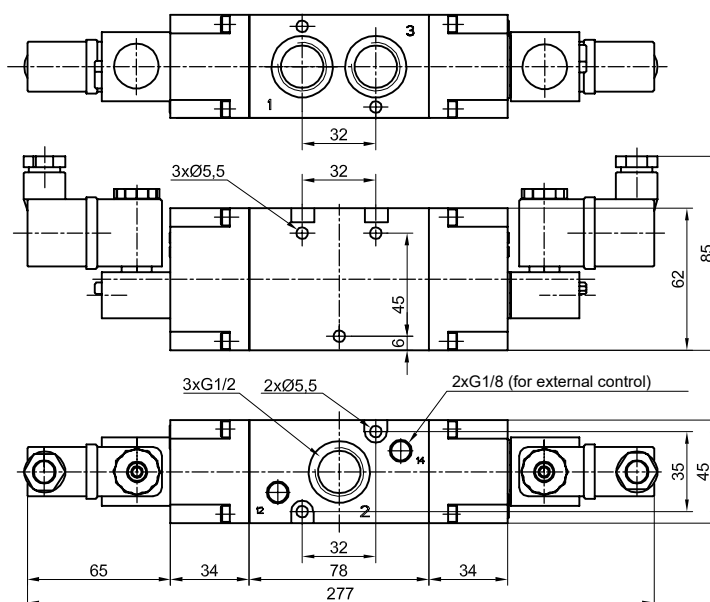
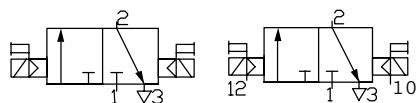

## VALVE ZDE 3/2 G1/2

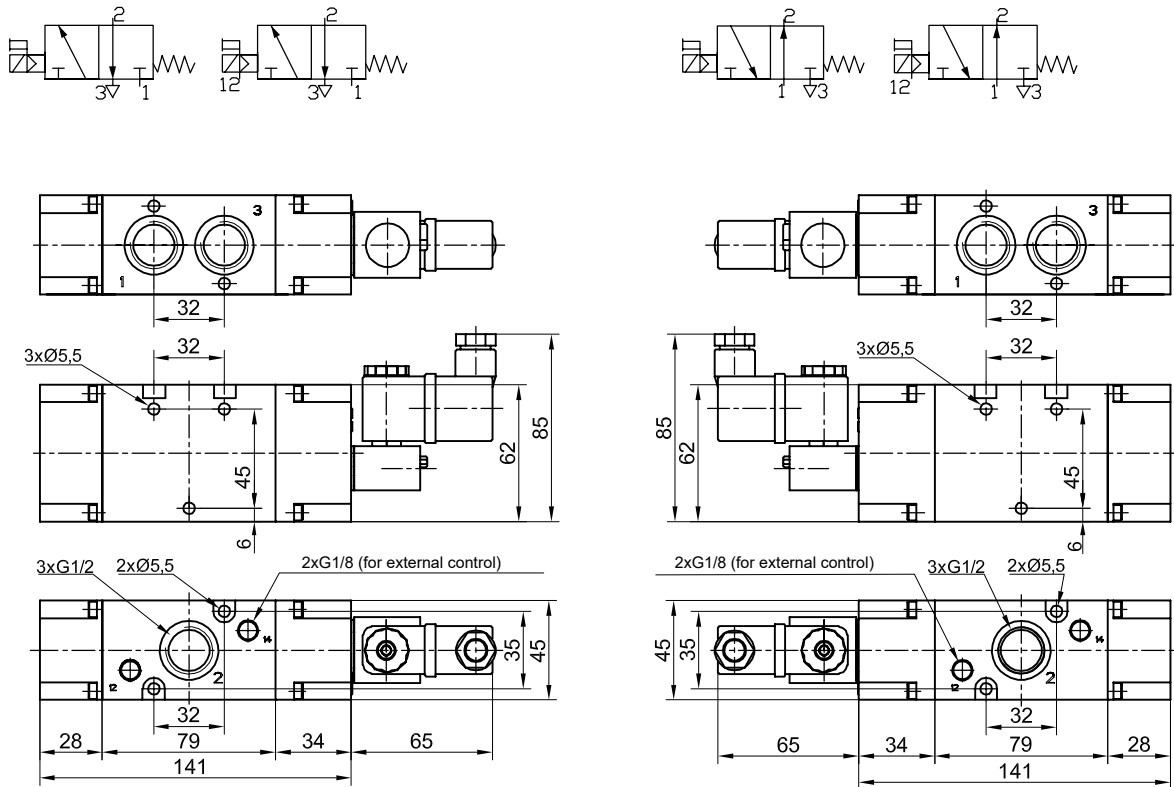

## VALVE ZDE 5/2 G1/2

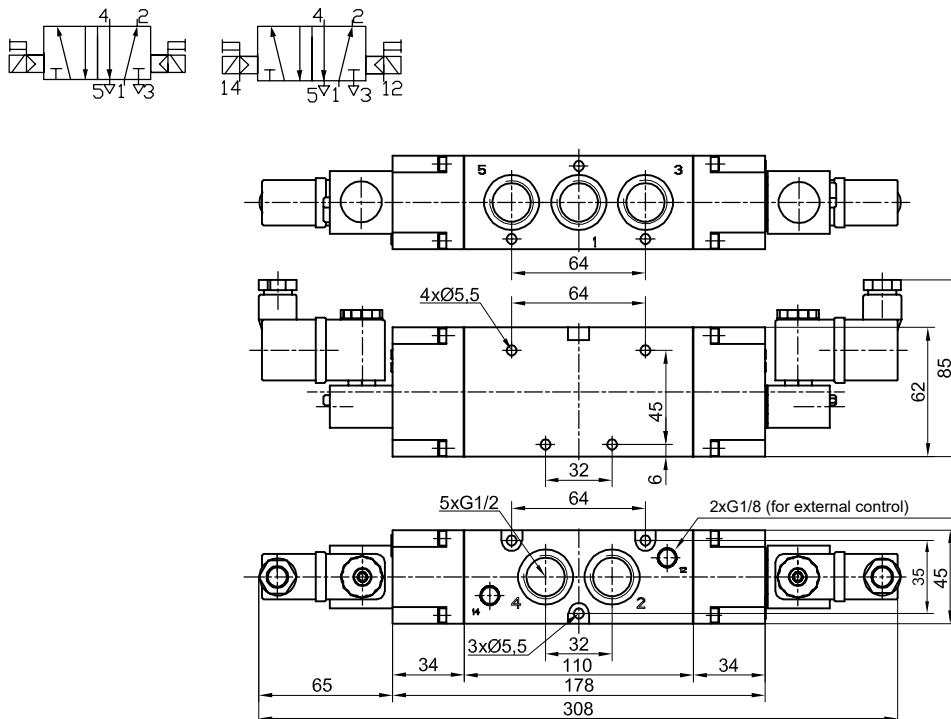

**Note:** in ZDE distribution valves, the external supply to the support valve is supplied to threaded connections marked 12 and 14 or 12 and 10.

# ZDE SERIES

Distribution valves

electromagnetically operated - wired supply



## VALVE ZDE 5/2 G1/2

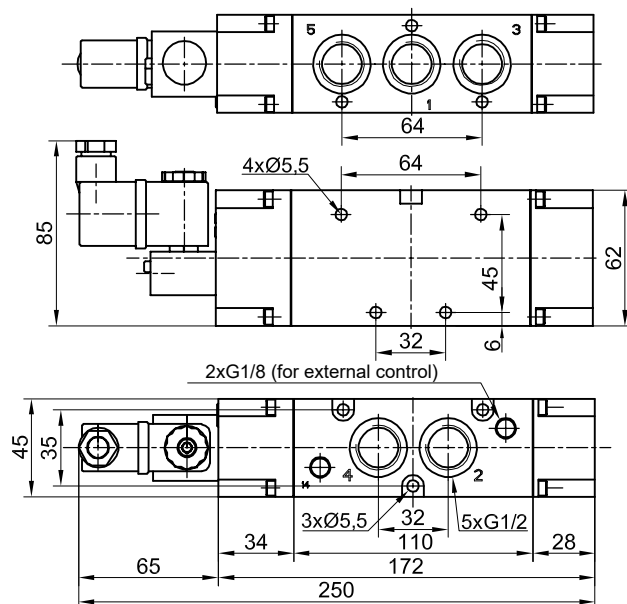
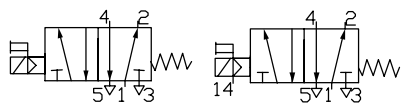

## VALVE ZDE 5/3 G1/2

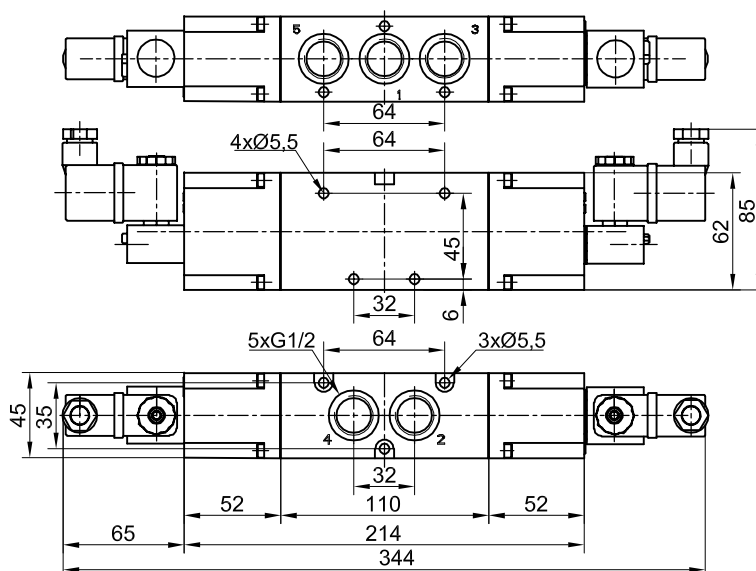
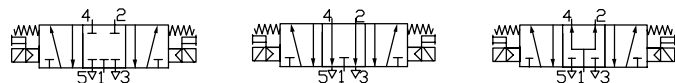

**Note:** in ZDE distribution valves, the external supply to the support valve is supplied to threaded connections marked 12 and 14 or 12 and 10.

### TECHNICAL SPECIFICATIONS

<b>Operating pressure range:</b>	according to the table
<b>Operating temperature range:</b>	0 to + 50°C
<b>Medium:</b>	compressed air, filtered, lubricated or non-lubricated
<b>Control voltage</b>	direct current: <b>A</b> - 12V <b>B</b> - 24V
<b>designation "x" in the order number:</b>	50 Hz alternating current: <b>E</b> - 24V <b>H</b> - 110V <b>J</b> - 230V
<b>Solenoid supply voltage:</b>	DC 12V, 24V +/-10% AC 24V, 110V, 230V +/- 10%
<b>Power consumption for the direct current:</b>	4.8-6.5W
<b>Power consumption for the alternating current:</b>	7-8.5VA
<b>Electrical protection:</b>	IP 65
<b>Construction materials:</b>	<p><b>Body</b> - aluminium alloy</p> <p><b>Covers</b> - plastic</p> <p><b>Slider</b> - aluminium alloy</p> <p><b>Seals</b> - polyurethane PU</p>

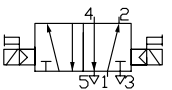
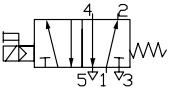

Number of paths / valve positions	Graphical symbol	Control type and operating pressure range	Connection thread	Nominal diameter	Order number
5/2		electromagnetic 1.5 — 10 bar	G3/8	Ø 11	22.1355.5238x
		electromagnetic single-side, spring return 3.0 — 10 bar			22.1352.5238x

### ORDERING PROCEDURE

In your order, please specify: name, number of paths / positions, connection thread, order number and number of pieces. In the place designated with "x", enter the letter code of the control voltage, e.g.

**Distribution valve ZE ISO 5/2 G3/8 electromagnetically operated, 230 V AC no. 22.1355.5238J 1 pc.**

# ZE ISO SERIES

Electromagnetically operated distribution valves  
compliant with ISO 5599/1 - for plate mounting



## VALVE ISO ZE 5/2

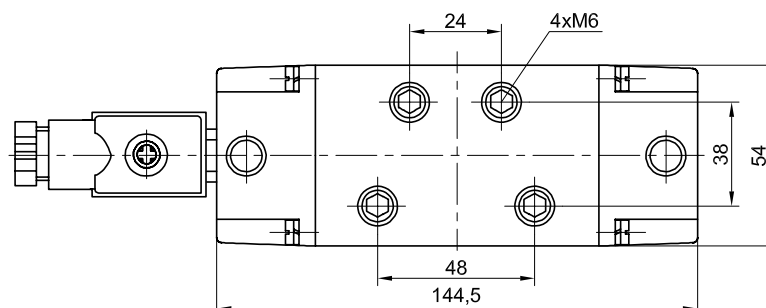
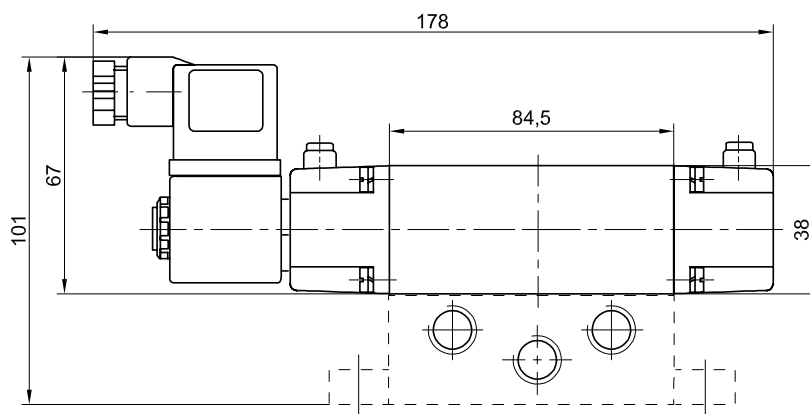
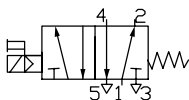
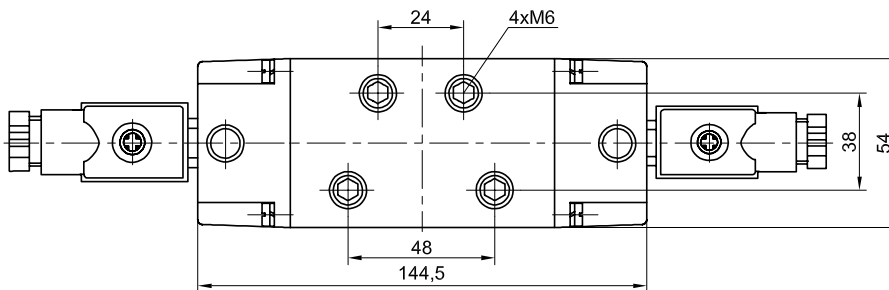
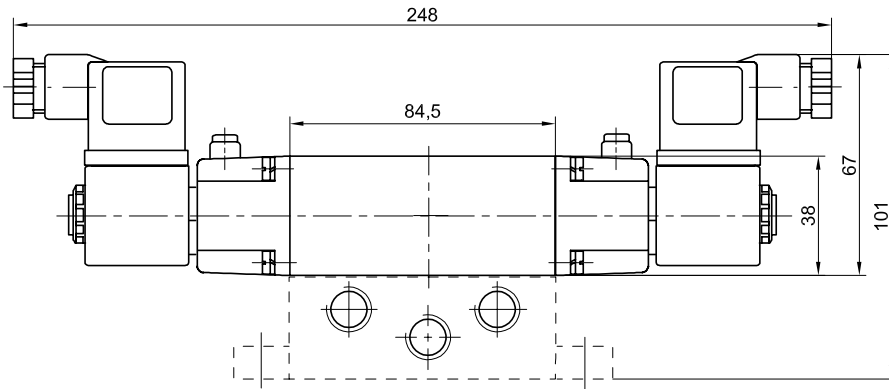
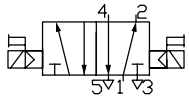

### TECHNICAL SPECIFICATIONS

<b>Operating pressure range:</b>	according to the table
<b>Operating temperature range:</b>	0 to + 50°C
<b>Medium:</b>	compressed air, filtered, lubricated or non-lubricated
<b>Control voltage</b>	<b>A</b> - 12V <b>B</b> - 24 V
<b>designation "x" in the order number:</b>	50 Hz alternating current: <b>E</b> - 24 V <b>H</b> - 110 V <b>J</b> - 230 V
<b>Solenoid supply voltage:</b>	DC 12V, 24V +/-10% AC 24V, 110V, 230V +/- 10%
<b>Power consumption for the direct current:</b>	4.8 - 6.5 W
<b>Power consumption for the alternating current:</b>	7 - 8.5 VA
<b>Construction materials:</b>	
<b>Body, covers</b>	- ZnAl alloy
<b>Slider</b>	- aluminium alloy anodized
<b>Seals</b>	- polyurethane PU



Number of paths / valve positions	Graphical symbol	Control type and operating pressure range	ISO size	Order number		
				Valve	Subplate connection thread	Subplate
5/2		electromagnetic 1.5 — 10 bar	2	22.0355.5202CWx	G1/4	25.0302.525314P
		electromagnetic and with external pressure* 0 — 10 bar			G3/8	25.0302.525338P
				electromagnetic, spring return 2.0 — 10 bar	G1/4	25.0302.525314P
	G3/8			25.0302.525338P		
		electromagnetic and with external pressure, spring return* 0 — 10 bar		G1/4	25.0302.525314P	
		G3/8		25.0302.525338P		
		electromagnetic, own pressure return (differential piston) 1.5 — 10 bar		G1/4	25.0302.525314P	
		G3/8		25.0302.525338P		
	electromagnetic and with external pressure, own pressure return (differential piston)* 0 — 10 bar	G1/4	25.0302.525314P			
	G3/8	25.0302.525338P				
	electromagnetic, external pressure return 1.5 — 10 bar	G1/4	25.0302.525314P			
	G3/8	25.0302.525338P				
	electromagnetic and with external pressure, external pressure return* 0 — 10 bar	G1/4	25.0302.525314P			
	G3/8	25.0302.525338P				



# ISO E SERIES

Electromagnetically operated distribution valves  
compliant with ISO 5599/1



Number of paths / valve positions	Graphical symbol	Control type and operating pressure range	ISO size	Order number		
				Valve	Subplate connection thread	Subplate
5/3		electromagnetic, in the middle position all paths cut off 2.0 — 10 bar	2	22.0356.5202CWx	G1/4	25.0302.525314P
					G3/8	25.0302.525338P
		electromagnetic and with external pressure*, in the middle position all paths cut off 0 — 10 bar		G1/4	25.0302.525314P	
				G3/8	25.0302.525338P	
		electromagnetic, in the middle position all paths vented 2.0 — 10 bar		G1/4	25.0302.525314P	
				G3/8	25.0302.525338P	
		electromagnetic and with external pressure*, in the middle position all paths vented 0 — 10 bar		G1/4	25.0302.525314P	
				G3/8	25.0302.525338P	

## ORDERING PROCEDURE

In your order, please specify: name, number of paths / positions, connection thread, order number and number of pieces. In the place designated with "x", enter the letter code of the control voltage, e.g.

**Distribution valve ISO 5/2 G3/8 electromagnetically operated, spring return, 230 V 50 Hz  
no. 22.0352.521438J 1 pc.**

### VALVE ISO E 5/2 with two coils and 5/3

### VALVE ISO E 5/2 with one coil

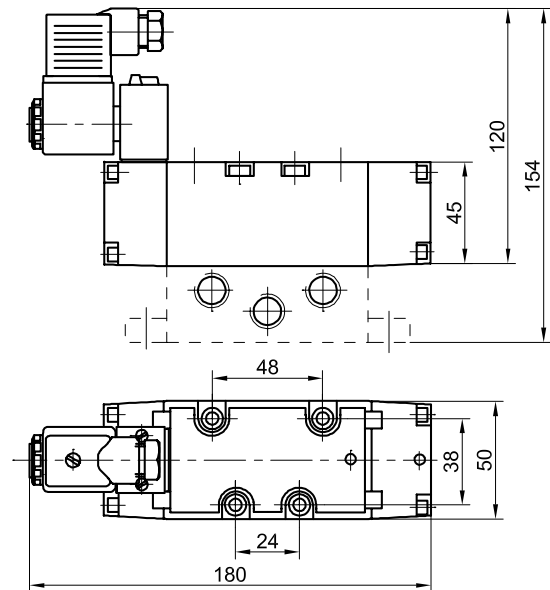
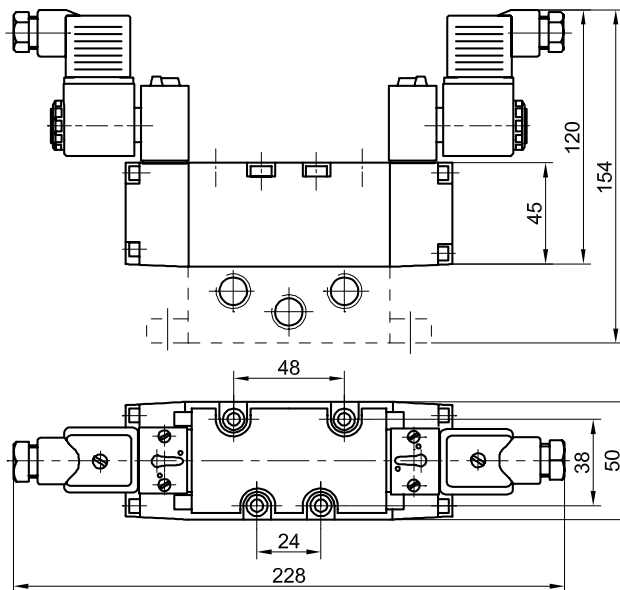

#### TECHNICAL SPECIFICATIONS

<b>Operating pressure range:</b>	according to the table
<b>Operating temperature range:</b>	0 to + 50°C
<b>Medium:</b>	compressed air, filtered, lubricated or non-lubricated
<b>Control voltage designation "x" in the order number:</b>	direct current: B - 24 V 50 Hz alternating current: E - 24 V H - 110 V J - 230 V
<b>Solenoid supply voltage:</b>	DC 24V +/-10% AC 24 V, 110 V, 230 V +/- 10%
<b>Power consumption for the direct current:</b>	4.8-6.5 W
<b>Power consumption for the alternating current:</b>	7-8.5 VA
<b>Electrical protection:</b>	IP 65
<b>Construction materials:</b>	
<b>Body, slider</b>	- aluminium alloy
<b>Covers</b>	- ZnAl alloy
<b>Seals</b>	- polyurethane PU



Valve function	Graphical symbol	Control type and operating pressure range	Connection thread	Nominal diameter	Order number
3/2		electromagnetic 2.0 — 10 bar	G1/8	Ø 5	<b>22.0201.3218x</b>
			G1/4	Ø 7.5	<b>22.0201.3214x</b>
		electromagnetic, spring return 3.0 — 10 bar	G1/8	Ø 5	<b>22.0203.3218x</b>
			G1/4	Ø 7.5	<b>22.0203.3214x</b>
3/3		electromagnetic, own pressure return (differential piston) 1.5 — 10 bar	G1/8	Ø 5	<b>22.0207.3218x</b>
			G1/4	Ø 7.5	<b>22.0207.3214x</b>
3/3		electromagnetic, middle position - cut off 3.0 — 10 bar	G1/8	Ø 5	<b>22.0209.3318x</b>
			G1/4	Ø 7.5	<b>22.0209.3314x</b>
5/2		electromagnetic 2.0 — 10 bar	G1/8	Ø 5	<b>22.0201.5218x</b>
			G1/4	Ø 7.5	<b>22.0201.5214x</b>
		electromagnetic, spring return 3.0 — 10 bar	G1/8	Ø 5	<b>22.0203.5218x</b>
			G1/4	Ø 7.5	<b>22.0203.5214x</b>
5/2		electromagnetic, own pressure return (differential piston) 1.5 — 10 bar	G1/8	Ø 5	<b>22.0207.5218x</b>
			G1/4	Ø 7.5	<b>22.0207.5214x</b>
5/3		electromagnetic, in the middle position all paths cut off 3.0 — 10 bar	G1/8	Ø 5	<b>22.0209.5318x</b>
			G1/4	Ø 7.5	<b>22.0209.5314x</b>
		electromagnetic, in the middle position all paths vented 3.0 — 10 bar	G1/8	Ø 5	<b>22.0211.5318x</b>
			G1/4	Ø 7.5	<b>22.0211.5314x</b>

# DTE SERIES

Distribution valves

electromagnetically operated - wired supply



## ORDERING PROCEDURE

In your order, please specify the name and function of the valve, connection thread, control voltage, order number and the number of pieces e.g.:

**Distribution valve 5/2 electromagnetically operated, spring return G3/8, wired, 230V 50Hz, order number 22.0204.521438J 1 pc.**

## VALVE DTE 3/2

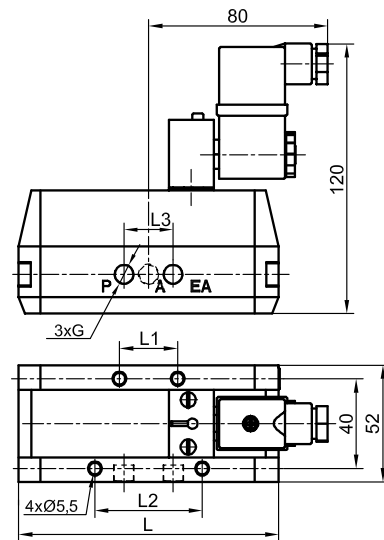
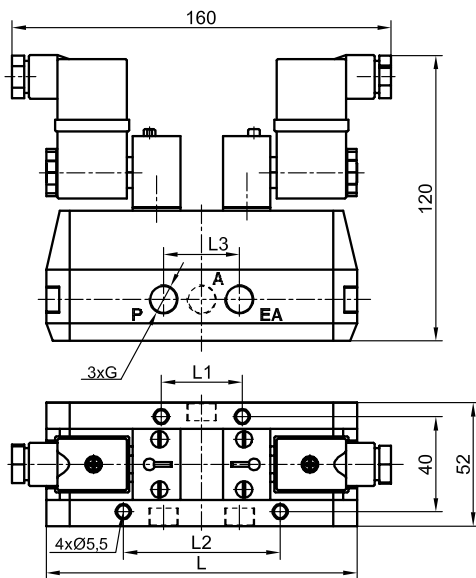
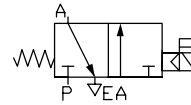
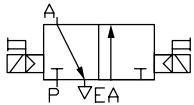

G	L	L1	L2	L3
G1/8	117	26	48	22
G1/4	132	34	66	32

G	L	L1	L2	L3
G1/8	117	26	48	22
G1/4	132	34	66	32

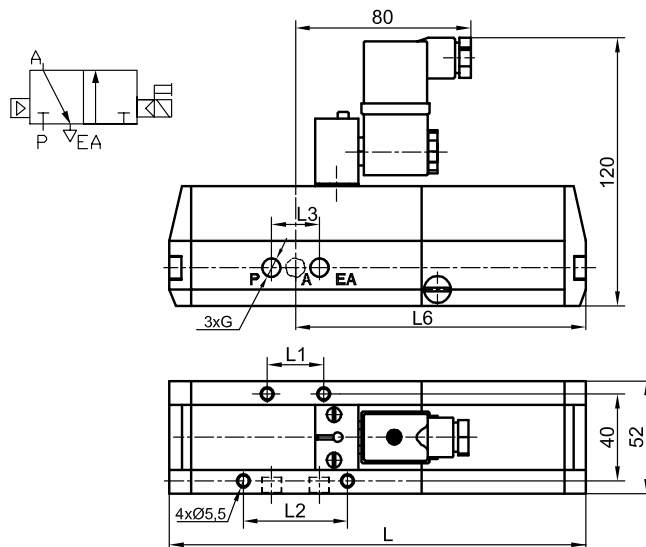

G	L	L1	L2	L3	L6
G1/8	155	26	48	22	96
G1/4	170	34	66	32	104

## VALVE DTE 3/3

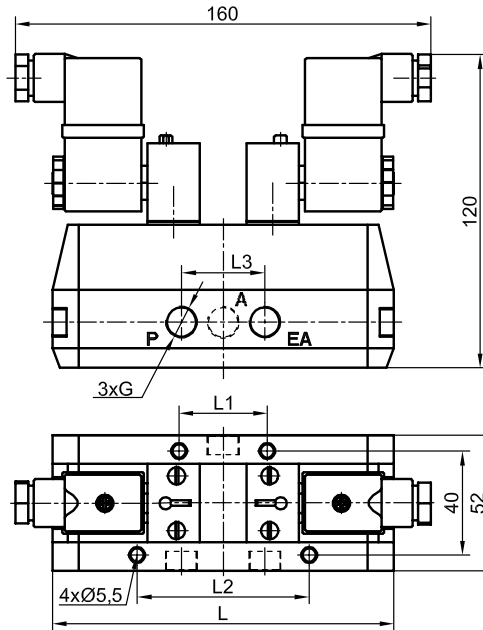
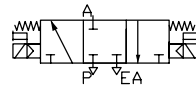

G	L	L1	L2	L3
G1/8	117	26	48	22
G1/4	132	34	66	32

## VALVE DTE 5/2

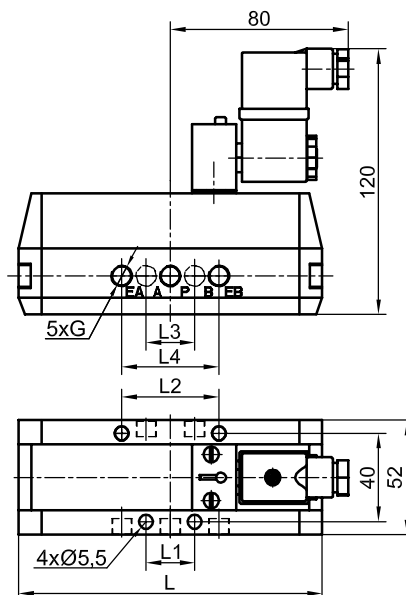
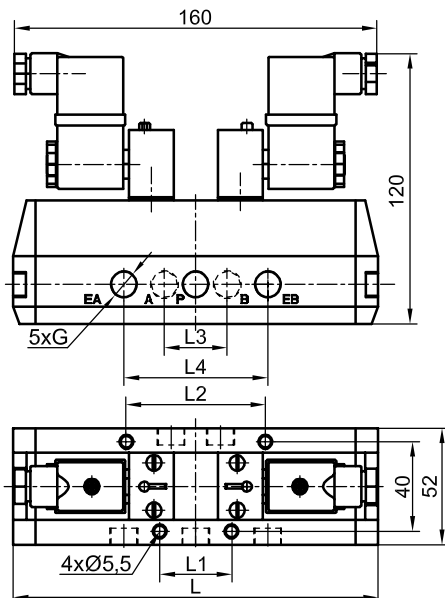
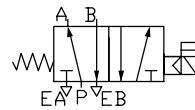
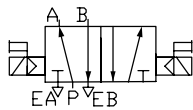

G	L	L1	L2	L3	L4
G1/8	139	22	44	22	44
G1/4	164	32	62	32	64

G	L	L1	L2	L3	L4
G1/8	139	22	44	22	44
G1/4	164	32	62	32	64

# DTE SERIES

Distribution valves

electromagnetically operated - wired supply



## VALVE DTE 5/2

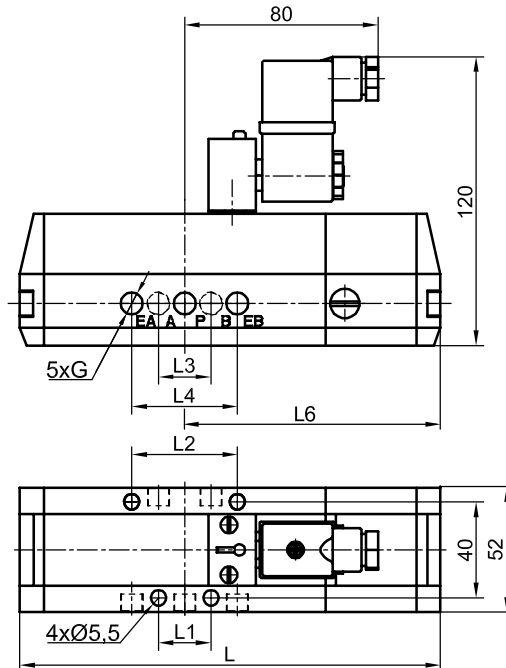
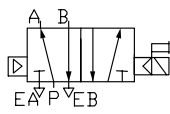

G	L	L1	L2	L3	L4	L6
G1/8	177	22	44	22	44	107
G1/4	202	32	62	32	64	120

## VALVE DTE 5/3

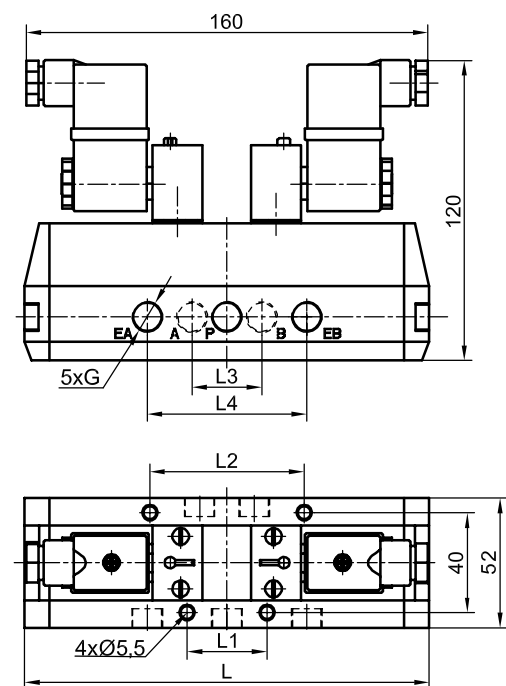
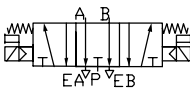

G	L	L1	L2	L3	L4
G1/8	139	22	44	22	44
G1/4	164	32	62	32	64

Support control valves type EVM for valves 22.02XX	catalogue page no. 4.01.05
Repair kits for DTE series valves	catalogue page no. 4.06.01

#### TECHNICAL SPECIFICATIONS

<b>Operating pressure range:</b>	according to the table
<b>Operating temperature range:</b>	0 to + 50°C
<b>Medium:</b>	compressed air, filtered, lubricated or non-lubricated
<b>Control voltage</b>	<b>A</b> - 12V <b>B</b> - 24 V
<b>designation "x" in the order number:</b>	50 Hz alternating current: <b>E</b> - 24 V <b>H</b> - 110 V <b>J</b> - 230 V
<b>Electrical protection:</b>	IP 65
<b>Solenoid supply voltage:</b>	DC 24V +/-10% AC 24V, 110V, 230V +/- 10%
<b>Power consumption for the direct current:</b>	G 1/4, G 3/8 - 4.8 - 6.5W G 1/2, G 3/4 - 10W
<b>Power consumption for the alternating current:</b>	G1/4, G3/8 - 7 - 8.5 VA G1/2, G 3/4 - 13,5 VA
<b>Construction materials:</b>	
<b>Body, slider</b>	- aluminium alloy
<b>Covers</b>	- ZnAl alloy
<b>Seals</b>	- polyurethane PU

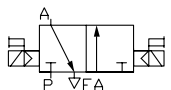
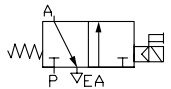
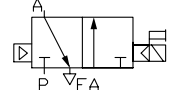
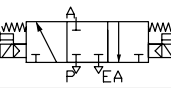
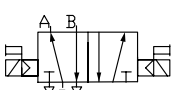
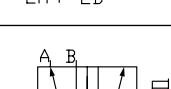
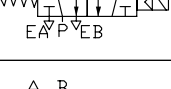

Valve function	Graphical symbol	Control type and operating pressure range	Connection thread	Nominal diameter	Order number	
					Valve	Subplate
3/2		electromagnetic 2.0 — 10 bar	G1/4	Ø 7.5	22.0202.3214x	25.0101.323314
			G3/8	Ø 12	22.0202.3238x	25.0101.323338
			G1/2	Ø 16	22.0902.3212x	25.0101.323312
		electromagnetic, spring return 3.0 — 10 bar	G1/4	Ø 7.5	22.0204.3214x	25.0101.323314
			G3/8	Ø 12	22.0204.3238x	25.0101.323338
			G1/2	Ø 16	22.0904.3212x	25.0101.323312
3/3		electromagnetic, own pressure return (differential piston) 1.5 — 10 bar	G1/4	Ø 7.5	22.0208.3214x	25.0101.323314
			G3/8	Ø 12	22.0208.3238x	25.0101.323338
			G1/2	Ø 16	22.0908.3212x	25.0101.323312
		electromagnetic, in the middle position all paths cut off 3.0 — 10 bar	G3/4	Ø 20	22.0908.3234x	25.0101.323334
			G1/4	Ø 7.5	22.0210.3314x	25.0101.323314
			G3/8	Ø 12	22.0210.3338x	25.0101.323338
5/2		electromagnetic 2.0 — 10 bar	G1/8	Ø 7.5	22.0202.521814x	25.0102.525318
			G1/4			25.0102.525314
			G1/4	Ø 12	22.0202.521438x	25.0103.525314
			G3/8			25.0103.525338
			G1/2	Ø 20	22.0902.521234x	25.0104.525312
			G3/4			25.0104.525334
		electromagnetic, spring return 3.0 — 10 bar	G1/8	Ø 7.5	22.0204.521814x	25.0102.525318
			G1/4			25.0102.525314
			G1/4	Ø 12	22.0204.521438x	25.0103.525314
			G3/8			25.0103.525338
			G1/2	Ø 20	22.0904.521234x	25.0104.525312
			G3/4			25.0104.525334
	electromagnetic, own pressure return (differential piston) 1.5 — 10 bar	G1/8	Ø 7.5	22.0208.521814x	25.0102.525318	
		G1/4			25.0102.525314	
		G1/4	Ø 12	22.0208.521438x	25.0103.525314	
		G3/8			25.0103.525338	
		G1/2	Ø 20	22.0908.521234x	25.0104.525312	
		G3/4			25.0104.525334	

# DTE SERIES

## Distribution valves

### electromagnetic control - for plate mounting



Valve function	Graphical symbol	Control type and operating pressure range	Connection thread	Nominal diameter	Order number	
					Valve	Subplate
5/3		electromagnetic, in the middle position all paths cut off 3.0 — 10 bar	G1/8	Ø 7.5	22.0210.531814x	25.0102.525318
			G1/4			25.0102.525314
			G1/4	Ø 12	22.0210.531438x	25.0103.525314
			G3/8			25.0103.525338
			G1/2	Ø 20	22.0910.531234x	25.0104.525312
			G3/4			25.0104.525334
		electromagnetic, in the middle position all paths vented 3.0 — 10 bar	G1/8	Ø 7.5	22.0212.531814x	25.0102.525318
			G1/4			25.0102.525314
			G1/4	Ø 12	22.0212.531438x	25.0103.525314
			G3/8			25.0103.525338
			G1/2	Ø 20	22.0912.531234x	25.0104.525312
			G3/4			25.0104.525334

### ORDERING PROCEDURE

In your order, please specify: name, number of valve paths/positions, connection thread and control voltage, order number and the number of pieces, e.g.:

**Distribution valve 5/2 electromagnetically operated, spring return G3/8, for plate mounting, 230 V 50 Hz, order no. 22.0204.521438J 1 pc.**

## VALVE DTE 3/2

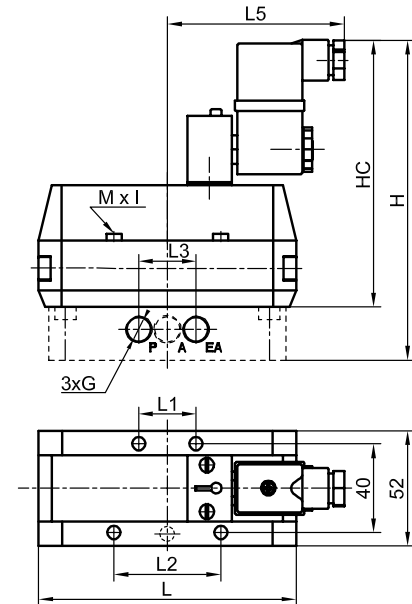
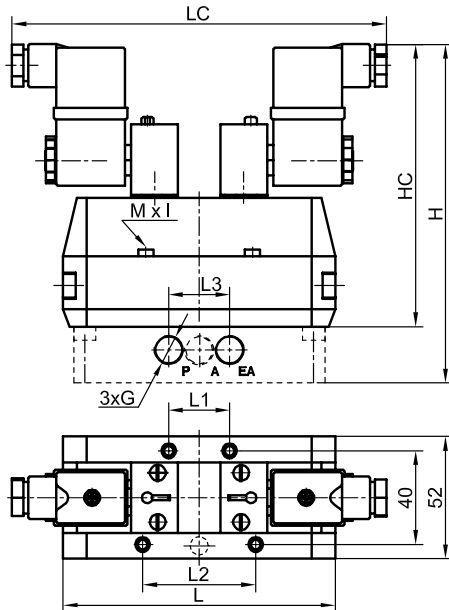
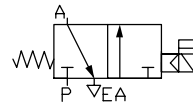
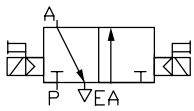

G	H	L	L1	L2	L3	LC	HC	MxI
G1/4	144	117	26	48	26	160	120	M5x50-4pcs
G3/8	149	132	34	66	35	160	120	M5x50-4pcs
G1/2	154	147	39	81	48	195	128	M5x50-4pcs
G3/4	159	172	52	92	52	195	128	M5x50-5pcs

G	H	L	L1	L2	L3	L5	HC	MxI
G1/4	144	117	26	48	26	80	120	M5x50-4pcs
G3/8	149	132	34	66	35	80	120	M5x50-4pcs
G1/2	154	147	39	81	48	96	128	M5x50-4pcs
G3/4	159	172	52	92	52	96	128	M5x50-5pcs

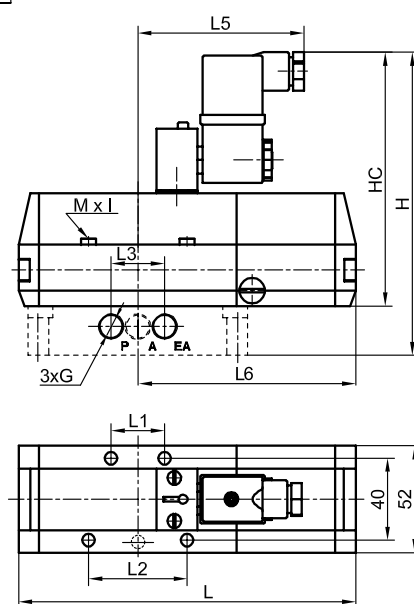
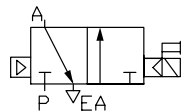

G	H	L	L1	L2	L3	L5	L6	HC	MxI
G1/4	144	155	26	48	26	80	96	120	M5x50-4pcs
G3/8	149	170	34	66	35	80	104	120	M5x50-4pcs
G1/2	154	195	39	81	48	96	121	128	M5x50-4pcs
G3/4	159	220	52	92	52	96	134	128	M5x50-5pcs



# DTE SERIES

Distribution valves

electromagnetic control - for plate mounting



## VALVE DTE 3/3

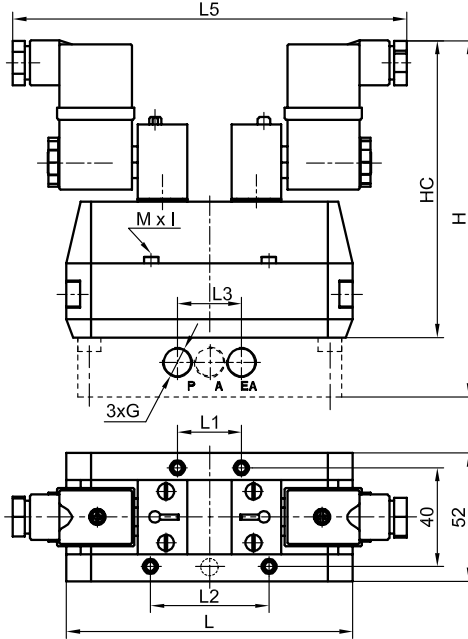
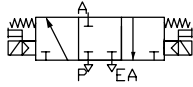

G	H	L	L1	L2	L3	L5	HC	Mxl
G1/4	144	117	26	48	26	160	120	M5x50-4pcs
G3/8	149	132	34	66	35	160	120	M5x50-4pcs
G1/2	154	147	39	81	48	192	128	M5x50-4pcs
G3/4	159	172	52	92	52	195	128	M5x50-5pcs

## VALVE DTE 5/2

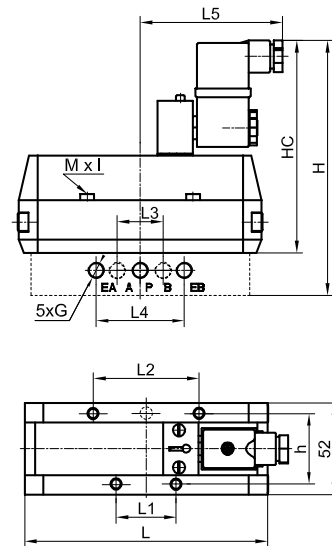
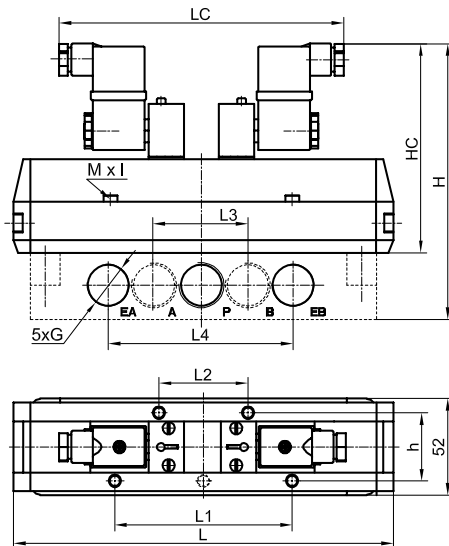
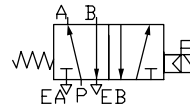
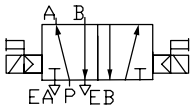

G	H	L	L1	L2	L3	L4	h	LC	HC	Mxl
G1/8-G1/4	164	139	60	34	26	56	40	160	120	M5x50-4pcs
G1/4-G3/8	150	164	86	48	35	70	42	160	120	M5x50-4pcs
G1/2-G3/4	158	224	104	52	52	104	40	195	128	M6x50-5pcs

G	H	L	L1	L2	L3	L4	L5	h	HC	Mxl
G1/8-G1/4	164	139	34	60	26	56	80	40	120	M5x50-4pcs
G1/4-G3/8	150	164	48	86	35	70	80	42	120	M5x50-4pcs
G1/2-G3/4	158	224	52	104	52	104	96	40	128	M6x50-5pcs

## VALVE DTE 5/2

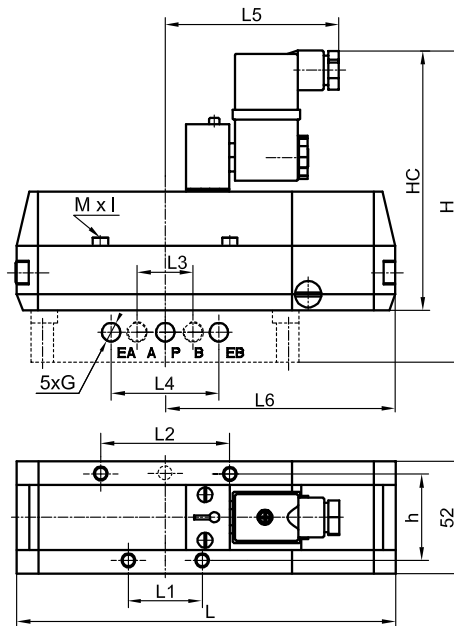
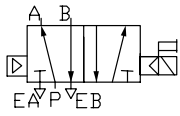

G	H	L	L1	L2	L3	L4	L5	L6	h	HC	Mxl
G1/8-G1/4	164	177	60	34	26	56	80	107	40	120	M5x50-4pcs
G1/4-G3/8	150	202	86	48	35	70	80	120	42	120	M5x50-4pcs
G1/2-G3/4	158	272	52	104	52	104	96	160	40	128	M6x50-5pcs

## VALVE DTE 5/3

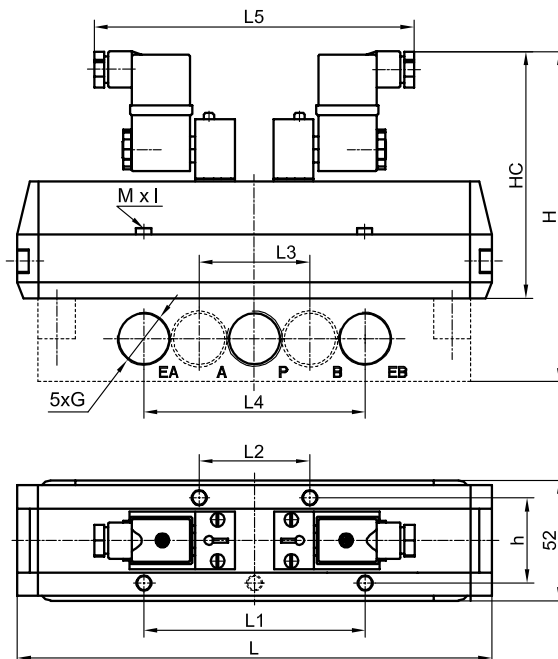
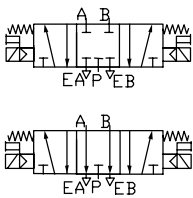

G	H	L	L1	L2	L3	L4	L5	h	HC	Mxl
G1/8-G1/4	164	139	34	60	26	56	160	40	120	M5x50-4pcs
G1/4-G3/8	150	164	48	86	35	70	160	42	120	M5x50-4pcs
G1/2-G3/4	158	224	104	52	52	104	192	40	128	M6x50-5pcs

Support control valves	- EVM type for valves 22.02XX	catalogue page no. 4.01.05
	- MVB type for valves 22.09XX	
Repair kits for DTE series valves		catalogue page no. 4.06.01



## TECHNICAL SPECIFICATIONS

<b>Operating pressure range:</b>	according to the table
<b>Operating temperature range:</b>	0 to + 65°C
<b>Medium:</b>	compressed air, filtered, lubricated or non-lubricated
<b>Construction materials:</b>	<p><b>Body</b> - aluminium alloy</p> <p><b>Covers</b> - plastic</p> <p><b>Slider</b> - stainless steel</p> <p><b>Seals</b> - polyurethane PU</p>



Number of paths / valve positions	Graphical symbol	Control type and operating pressure range	Connection thread	Nominal diameter	Order number
3/2		pneumatic 1.5 — 10 bar	G1/8	Ø 5	<b>23.0701.3218</b>
		pneumatic, spring and own pressure return 2.0 — 10 bar	G1/4	Ø 6	<b>23.0701.3214</b>
			G1/8	Ø 5	<b>23.0703.3218</b>
3/2		pneumatic, spring return 2.0 — 10 bar	G1/4	Ø 6	<b>23.0703.3214</b>
			G1/8	Ø 5	<b>23.0703.3218NO</b>
5/2		pneumatic 1.5 — 10 bar	G1/8	Ø 5	<b>23.0701.5218</b>
			G1/4	Ø 6	<b>23.0701.5214</b>
5/2		pneumatic, spring and own pressure return 2.0 — 10 bar	G1/8	Ø 5	<b>23.0703.5218</b>
			G1/4	Ø 6	<b>23.0703.5214</b>
5/3		pneumatic double-side, in the middle position all paths cut off 3.0 — 10 bar	G1/8	Ø 5	<b>23.0709.5318</b>
			G1/4	Ø 6	<b>23.0709.5314</b>
		pneumatic double-side, in the middle position all paths vented 3.0 — 10 bar	G1/8	Ø 5	<b>23.0710.5318</b>
G1/4			Ø 6	<b>23.0710.5314</b>	
5/3		pneumatic double-side, in the middle position all paths connected to the supply 3.0 — 10 bar	G1/8	Ø 5	<b>23.0711.5318</b>
			G1/4	Ø 6	<b>23.0711.5314</b>

## ORDERING PROCEDURE

In your order, please specify the name and function of the valve, connection thread, order number and the number of pieces, e.g.:

**Distribution valve 5/2 G1/8 pneumatically operated, spring and pressure return, no. 23.0703.5218 1 pc.**

# ZMG P SERIES

Compact distribution valves  
pneumatically operated - wired



## VALVE ZMG P 3/2 G1/8

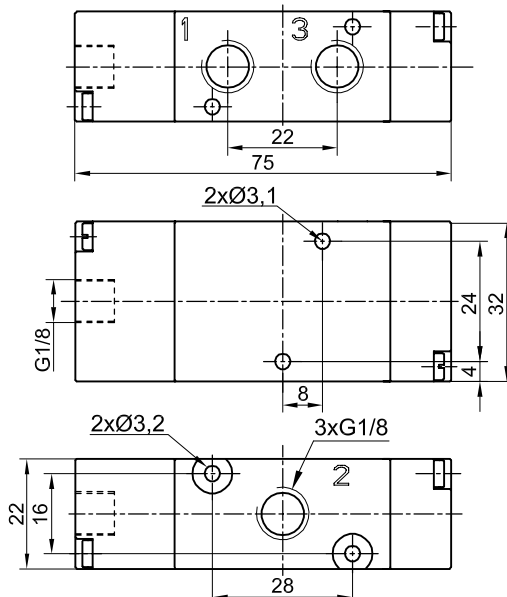
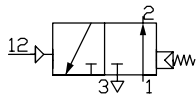
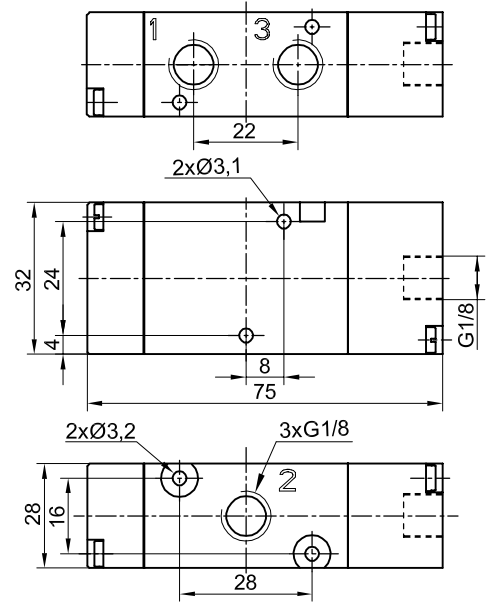
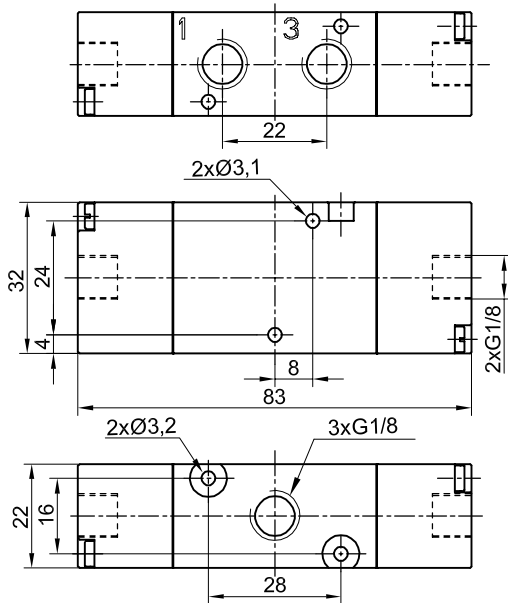
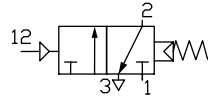
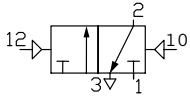

## VALVE ZMG P 3/2 G1/4

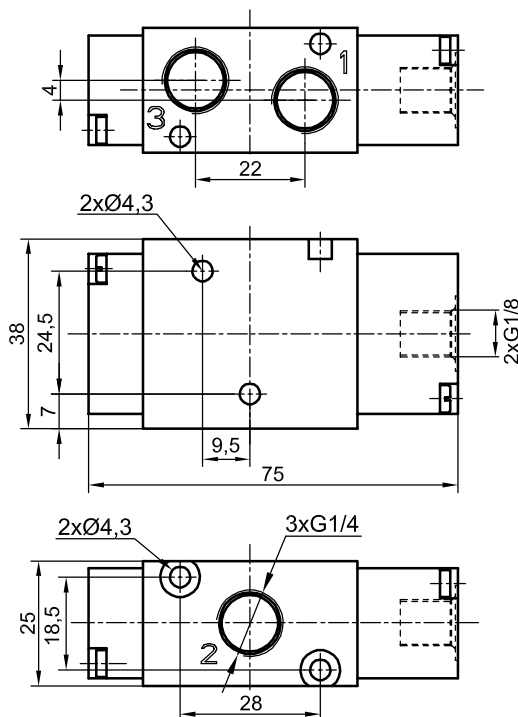
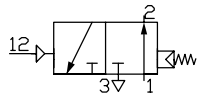
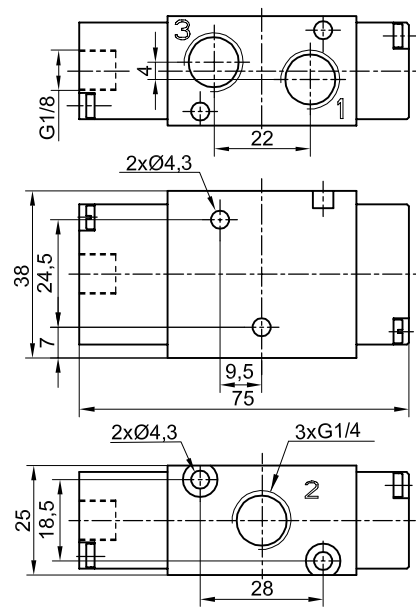
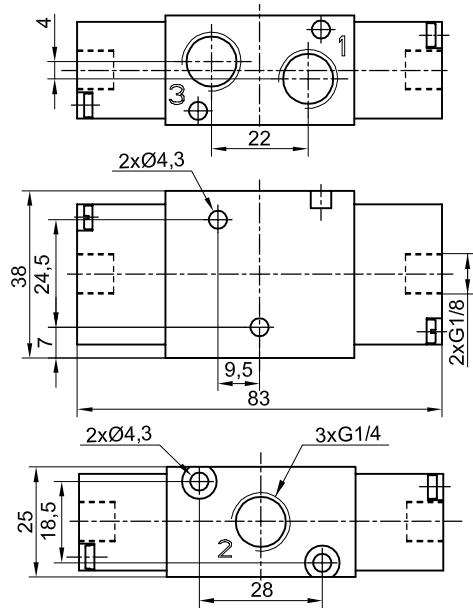
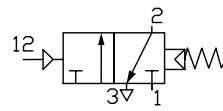
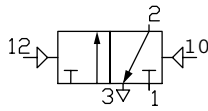

# ZMG P SERIES

Compact distribution valves  
pneumatically operated - wired



## VALVE ZMG P 5/2 G1/8

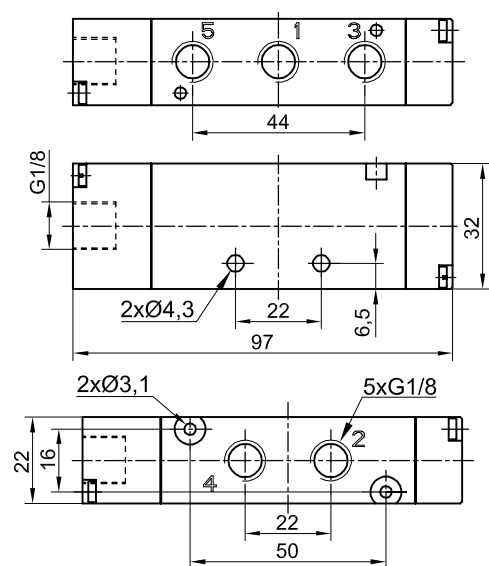
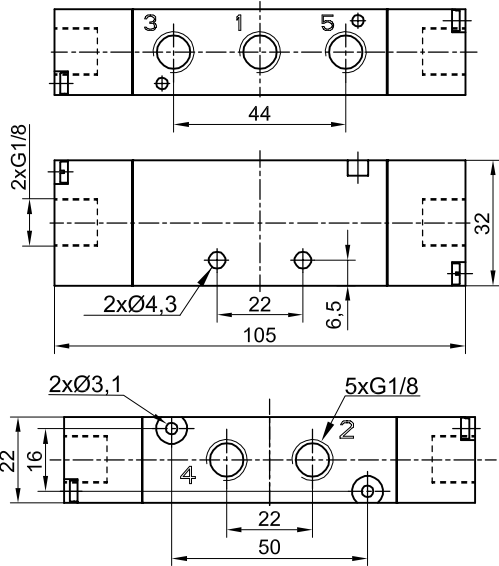
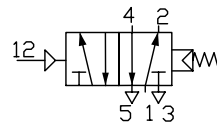
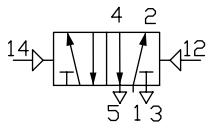

## VALVE ZMG P 5/2 G1/4

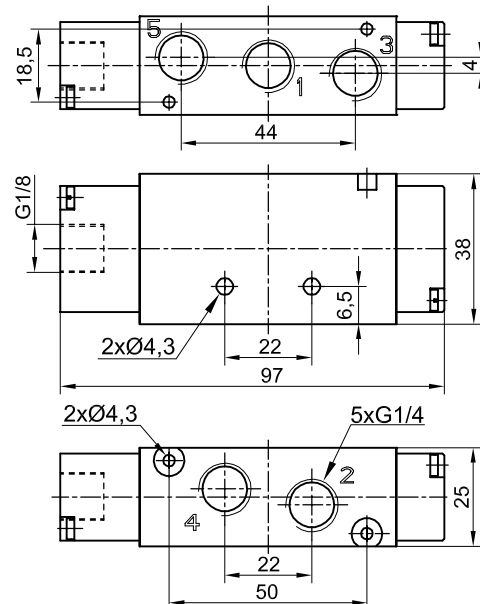
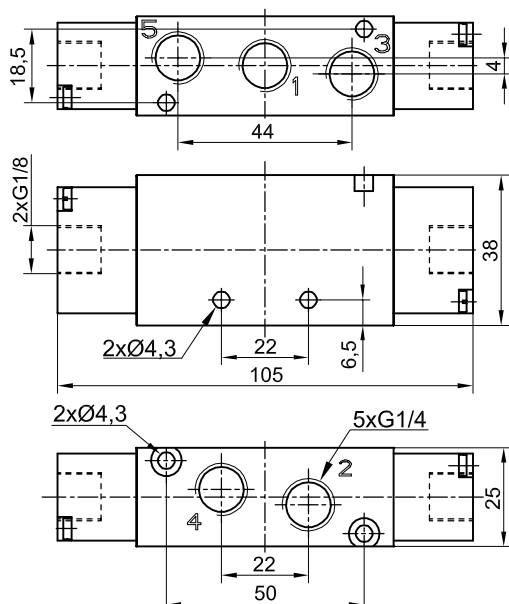
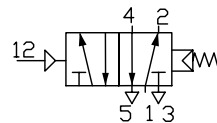
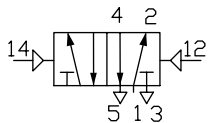

## VALVE ZMG P 5/3 G1/8

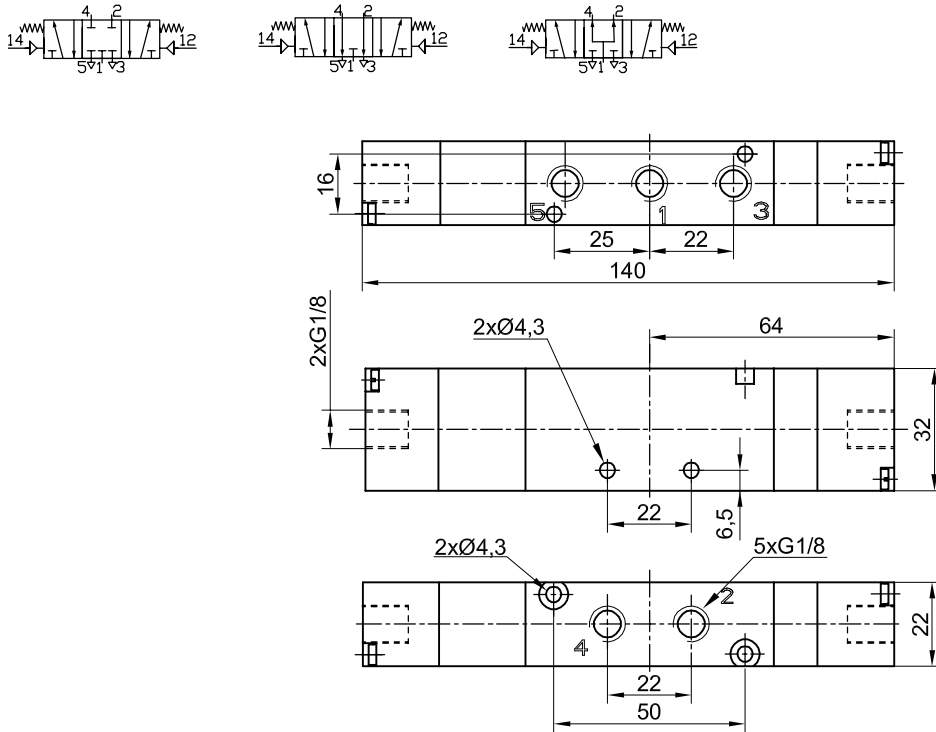

## VALVE ZMG P 5/3 G1/4

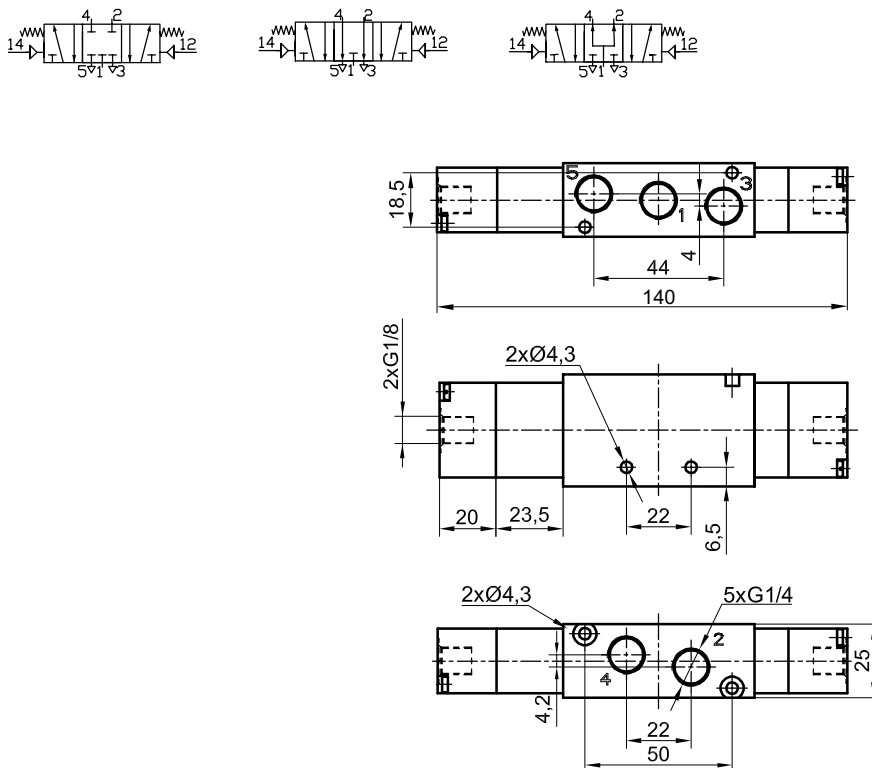





### TECHNICAL SPECIFICATIONS

<b>Operating pressure range:</b>	according to the table
<b>Operating temperature range:</b>	0 to + 65°C
<b>Medium:</b>	compressed air, filtered, lubricated or non-lubricated
<b>Construction materials:</b>	<p><b>Body</b> - aluminium alloy</p> <p><b>Covers</b> - plastic</p> <p><b>Slider</b> - aluminium alloy anodized</p> <p><b>Seals</b> - polyurethane PU</p>



Number of paths / valve positions	Graphical symbol	Control type and operating pressure range	Connection thread	Nominal diameter	Order number		
3/2		pneumatic double-side 1.5 — 10 bar	G3/8	Ø 11	<b>23.0801.3238</b>		
		pneumatic, spring return 3.0 — 10 bar			<b>23.0803.3238</b>		
		pneumatic single-side, own pressure return (differential piston) 1.5 — 10 bar			<b>23.0805.3238</b>		
3/3		pneumatic double-side, in the middle position all paths cut off 1.5 — 10 bar					<b>23.0809.3338</b>
5/2		pneumatic double-side 1.5 — 10 bar					<b>23.0801.5238</b>
		pneumatic, spring return 3.0 — 10 bar					<b>23.0803.5238</b>
		pneumatic single-side, own pressure return (differential piston) 1.5 — 10 bar					<b>23.0805.5238</b>
		pneumatic single-side, external pressure return (differential piston) 3.0 — 10 bar			<b>23.0807.5238</b>		

# ZP SERIES

## Pneumatically operated distribution valves



Number of paths / valve positions	Graphical symbol	Control type and operating pressure range	Connection thread	Nominal diameter	Order number
5/3		pneumatic double-side, in the middle position all paths cut off 3.0 — 10 bar	G3/8	Ø 11	<b>23.0809.5338</b>
		pneumatic double-side, in the middle position all paths vented 3.0 — 10 bar			<b>23.0810.5338</b>
		pneumatic double-side, in the middle position all paths connected to the supply 3.0 — 10 bar			<b>23.0811.5338</b>

### ORDERING PROCEDURE

In your order, please specify the name of the valve, number of paths/positions, connection thread, order number and the number of pieces, e.g.:

**Distribution valve ZP 5/2 G3/8 pneumatically operated, spring return, no. 23.0803.5238 1 pc.**

### VALVE ZP 3/2 G3/8

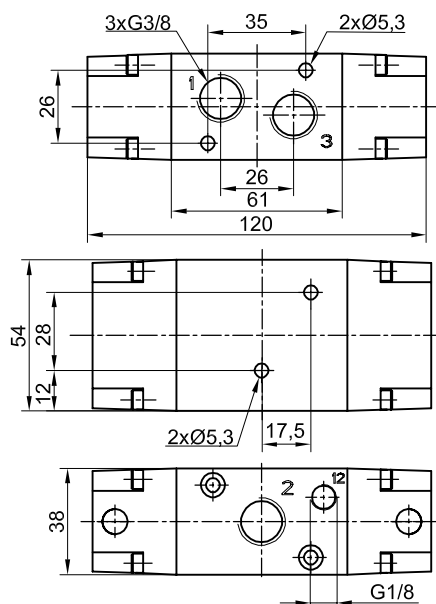
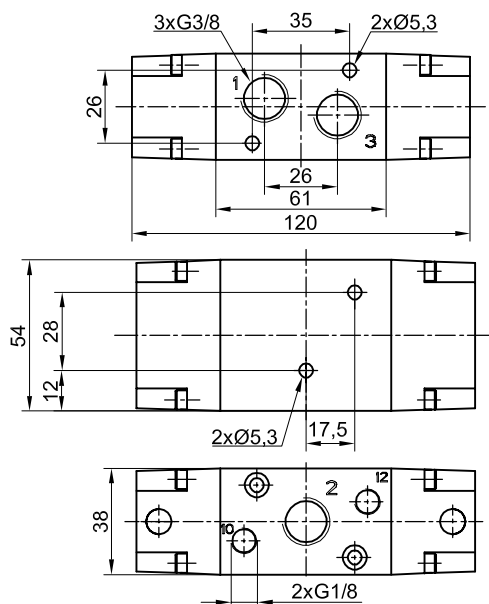
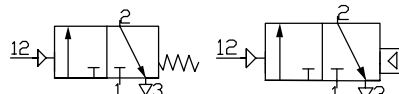
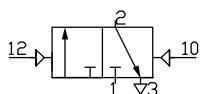

## VALVE ZP 3/3 G3/8

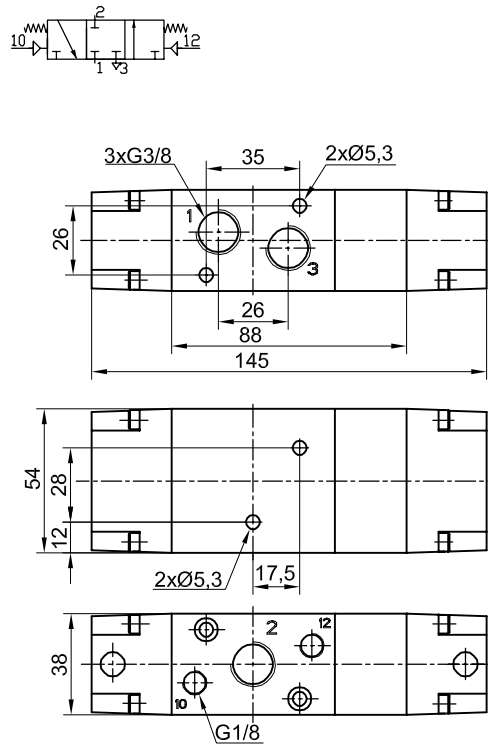

## VALVE ZP 5/2 G3/8

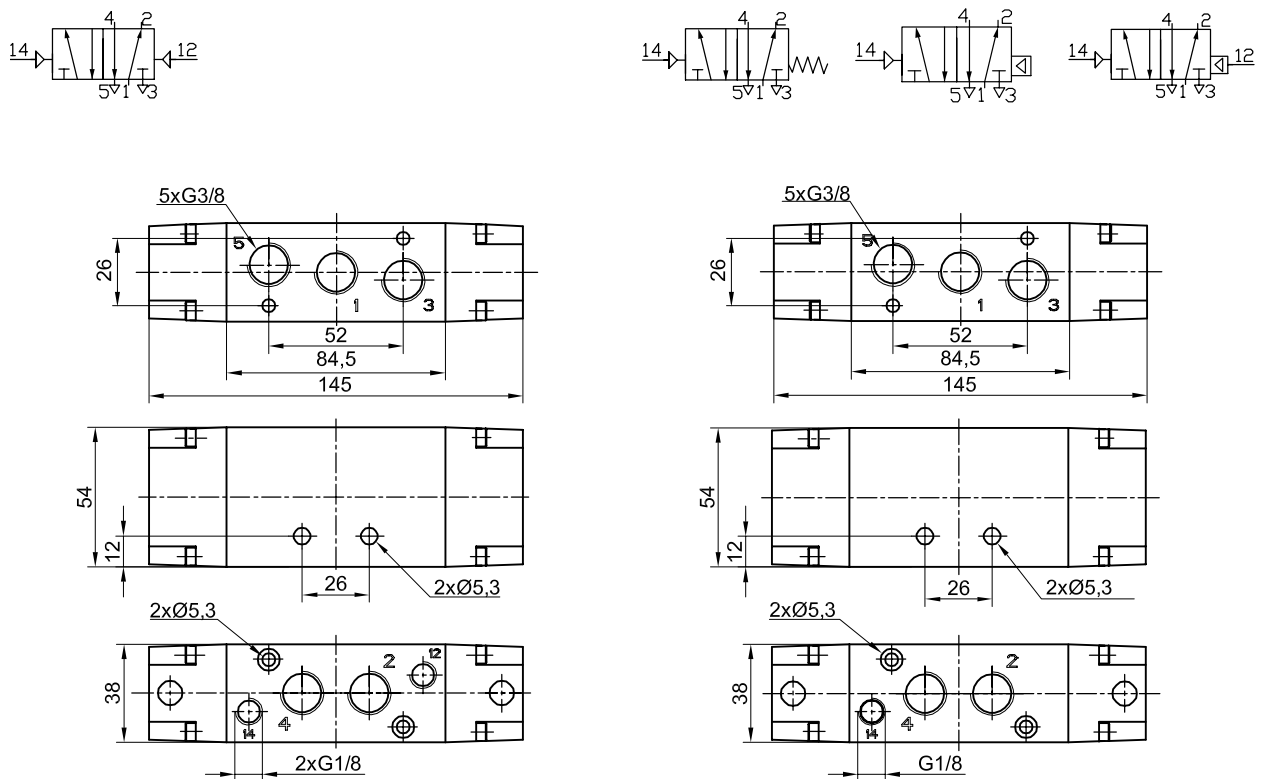

# ZP SERIES

Pneumatically operated distribution valves



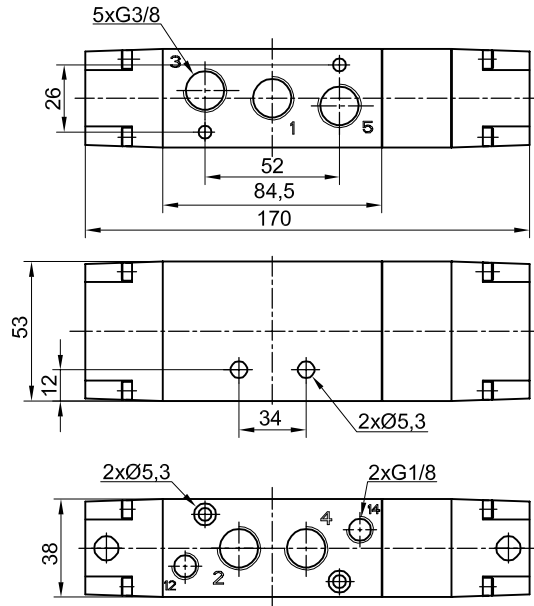
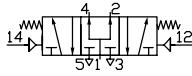
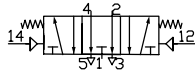
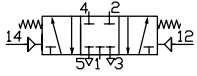

## VALVE ZP 5/3 G3/8



## TECHNICAL SPECIFICATIONS

<b>Operating pressure range:</b>	according to the table
<b>Operating temperature range:</b>	-10 to + 65°C
<b>Medium:</b>	compressed air, filtered, lubricated or non-lubricated
<b>Construction materials:</b>	<p><b>Body</b> - ZnAl alloy</p> <p><b>Covers</b> - ZnAl alloy</p> <p><b>Slider</b> - aluminium alloy, anodised</p> <p><b>Seals</b> - polyurethane PU</p>

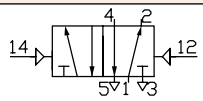
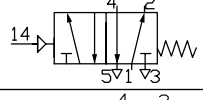
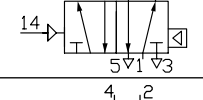

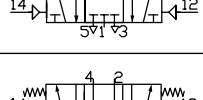
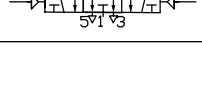
Number of paths / valve positions	Graphical symbol	Control type and operating pressure range	Connection thread	ISO size	ISO designation	Order number
5/2		pneumatic 1.5 — 10 bar	G3/8	2	201	<b>23.0301.521438</b>
		pneumatic, spring return 2.0 — 10 bar		2	204	<b>23.0304.521438</b>
		pneumatic, own pressure return (differential piston) 1.5 — 10 bar		2	202	<b>23.0302.521438</b>
		pneumatic, external pressure return (differential piston) 2.0 — 10 bar		2	203	<b>23.0303.521438</b>
5/3		pneumatic, in the middle position all paths cut off 2.0 — 10 bar		2	206	<b>23.0306.531438</b>
		pneumatic, in the middle position all paths vented 2.0 — 10 bar		2	208	<b>23.0308.531438</b>

## ORDERING PROCEDURE

In your order, please specify the name of the valve, number of paths/positions, connection thread, order number and the number of pieces, e.g.:

**Distribution valve ISO 5/3 G3/8 pneumatically operated, in the middle position all paths cut off, no. 23.0306.531438 1 pc.**

# ISO P SERIES

Distribution valves

pneumatically operated compliant with ISO 5599/1



## VALVE ISO P 5/2 AND 5/3

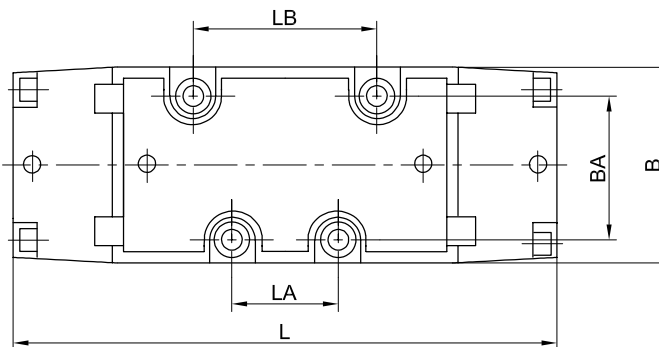
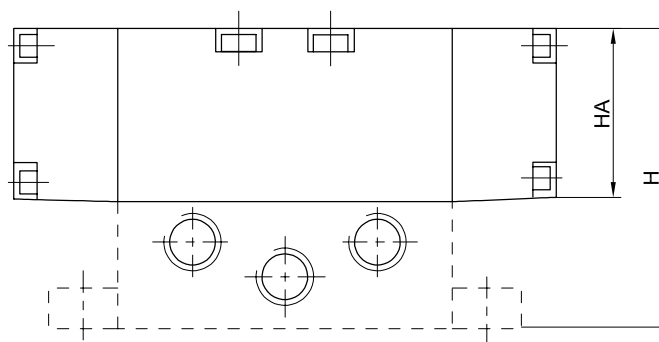
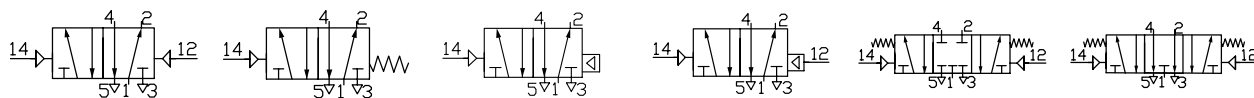

ISO SIZE	B	BA	L	LA	LB	H	HA
2	50	38	140	24	48	149	45

## TECHNICAL SPECIFICATIONS

<b>Operating pressure range:</b>	according to the table
<b>Operating temperature range:</b>	0 to + 65°C
<b>Medium:</b>	compressed air, filtered, lubricated or non-lubricated
<b>Construction materials:</b>	<p><b>Body</b> - aluminium alloy</p> <p><b>Covers</b> - ZnAl alloy</p> <p><b>Slider</b> - aluminium alloy</p> <p><b>Seals</b> - polyurethane PU</p>



Number of paths / valve positions	Graphical symbol	Control type and operating pressure range	Connection thread	Nominal diameter	Order number
3/2		pneumatic 2.0 — 10 bar	G1/8	Ø 5	<b>23.0101.3218</b>
			G1/4	Ø 7.5	<b>23.0101.3214</b>
		pneumatic, spring return 3.0 — 10 bar	G1/8	Ø 5	<b>23.0103.3218</b>
			G1/4	Ø 7.5	<b>23.0103.3214</b>
		pneumatic, with low pressure signal 1.5 — 10 bar	G1/8	Ø 5	<b>23.0107.3218</b>
			G1/4	Ø 7.5	<b>23.0107.3214</b>
		pneumatic with low-pressure signal, spring return 1.5 — 10 bar	G1/8	Ø 5	<b>23.0109.3218</b>
			G1/4	Ø 7.5	<b>23.0109.3214</b>
		pneumatic, with a differential piston 1.5 — 10 bar	G1/8	Ø 5	<b>23.0105.3218</b>
			G1/4	Ø 7.5	<b>23.0105.3214</b>
3/3		pneumatic, in the middle position all paths cut off 3.0 — 10 bar	G1/8	Ø 5	<b>23.0111.3318</b>
			G1/4	Ø 7.5	<b>23.0111.3314</b>



# DTP SERIES

## Pneumatically operated distribution valves - wired



Number of paths / valve positions	Graphical symbol	Control type and operating pressure range	Connection thread	Nominal diameter	Order number
5/2		pneumatic 2.0 — 10 bar	G1/8	Ø 5	<b>23.0101.5218</b>
			G1/4	Ø 7.5	<b>23.0101.5214</b>
		pneumatic, spring return 3.0 — 10 bar	G1/8	Ø 5	<b>23.0103.5218</b>
			G1/4	Ø 7.5	<b>23.0103.5214</b>
		pneumatic, with low pressure signal 1.5 — 10 bar	G1/8	Ø 5	<b>23.0107.5218</b>
			G1/4	Ø 7.5	<b>23.0107.5214</b>
		pneumatic with low-pressure signal, spring return 1.5 — 10 bar	G1/8	Ø 5	<b>23.0109.5218</b>
			G1/4	Ø 7.5	<b>23.0109.5214</b>
		pneumatic, with a differential piston 1.5 — 10 bar	G1/8	Ø 5	<b>23.0105.5218</b>
			G1/4	Ø 7.5	<b>23.0105.5214</b>
5/3		pneumatic, in the middle position all paths cut off 3.0 — 10 bar	G1/8	Ø 5	<b>23.0111.5318</b>
			G1/4	Ø 7.5	<b>23.0111.5314</b>
		pneumatic, in the middle position all paths vented 3.0 — 10 bar	G1/8	Ø 5	<b>23.0113.5318</b>
			G1/4	Ø 7.5	<b>23.0113.5314</b>

### ORDERING PROCEDURE

In your order, please specify the name and function of the valve, connection thread, order number and the number of pieces, e.g.:

**Distribution valve 5/2 G1/4 pneumatically operated, spring return, wired,  
order number 23.0103.5214 1 pc.**

## VALVE DTP 3/2

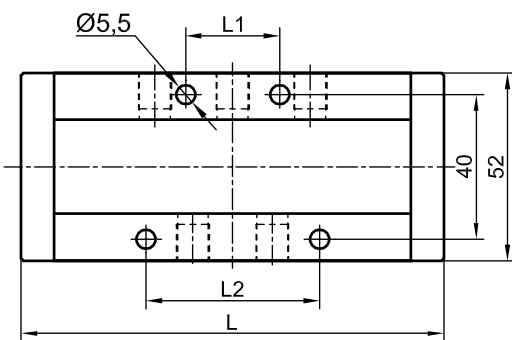
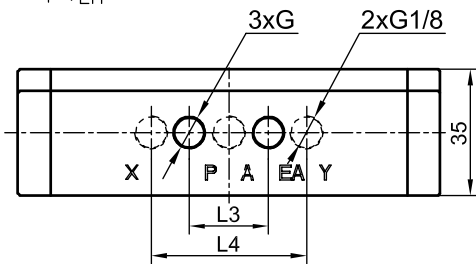
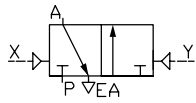

G	L	L1	L2	L3	L4
G1/8	117	26	48	22	43
G1/4	132	34	66	32	58

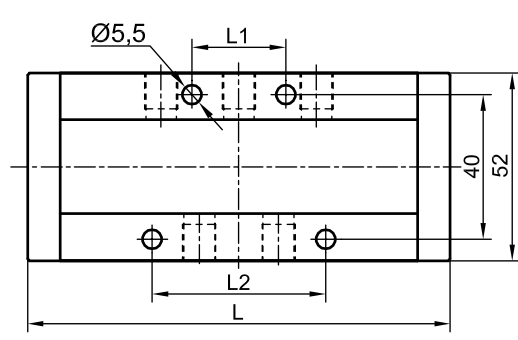
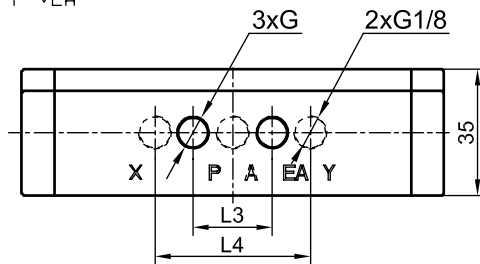
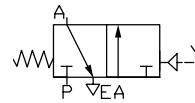

G	L	L1	L2	L3	L4
G1/8	117	26	48	22	43
G1/4	132	34	66	32	58

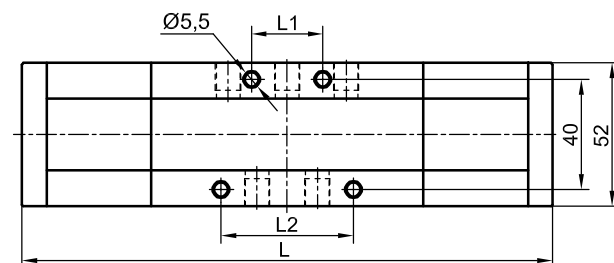
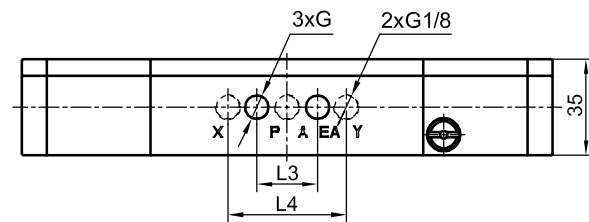
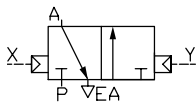

G	L	L1	L2	L3	L4
G1/8	193	26	48	22	43
G1/4	208	34	66	32	58

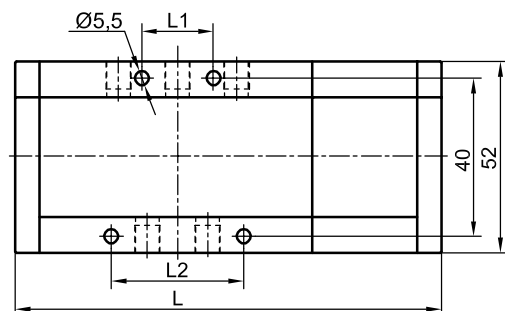
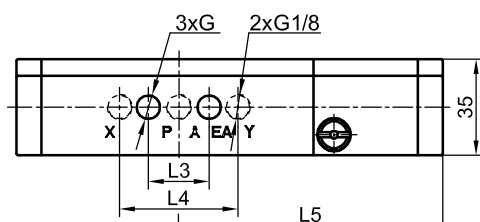
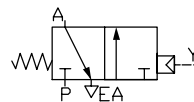

G	L	L1	L2	L3	L4	L5
G1/8	155	26	48	22	43	96
G1/4	170	34	66	32	58	104

# DTP SERIES

Pneumatically operated distribution valves - wired



## VALVE DTP 3/2

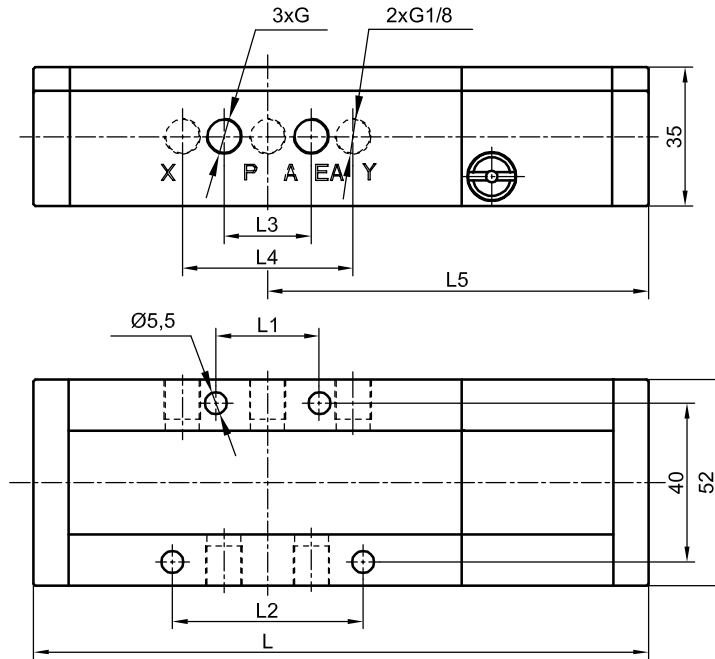
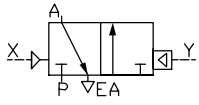

G	L	L1	L2	L3	L4	L5
G1/8	155	26	48	22	43	96
G1/4	170	34	66	32	58	104

## VALVE DTP 3/3

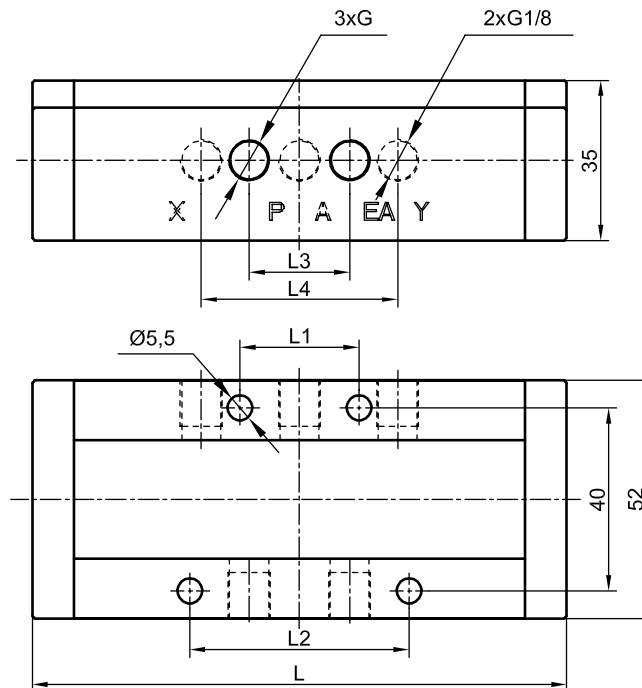
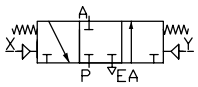

G	L	L1	L2	L3	L4
G1/8	117	26	48	22	43
G1/4	132	34	66	32	58

## VALVE DTP 5/2

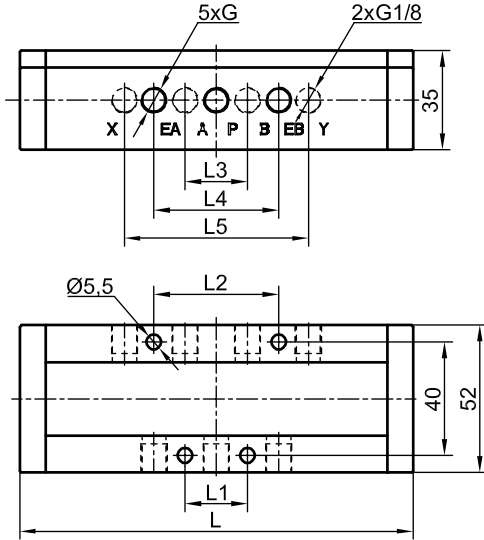
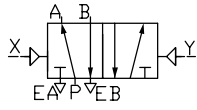

G	L	L1	L2	L3	L4	L5
G1/8	139	22	44	22	44	65
G1/4	164	32	62	32	64	90

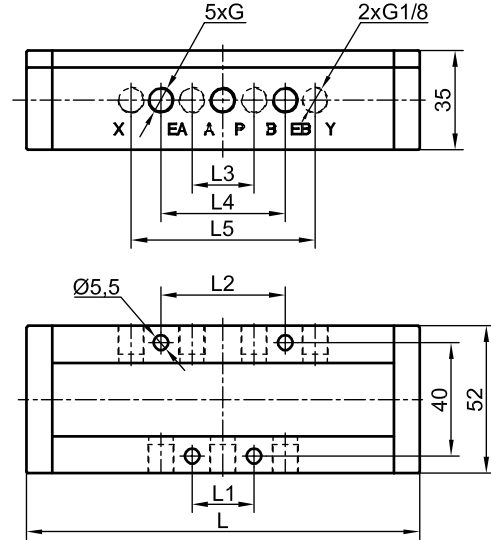
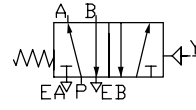

G	L	L1	L2	L3	L4	L5
G1/8	139	22	44	22	44	65
G1/4	164	32	62	32	64	90

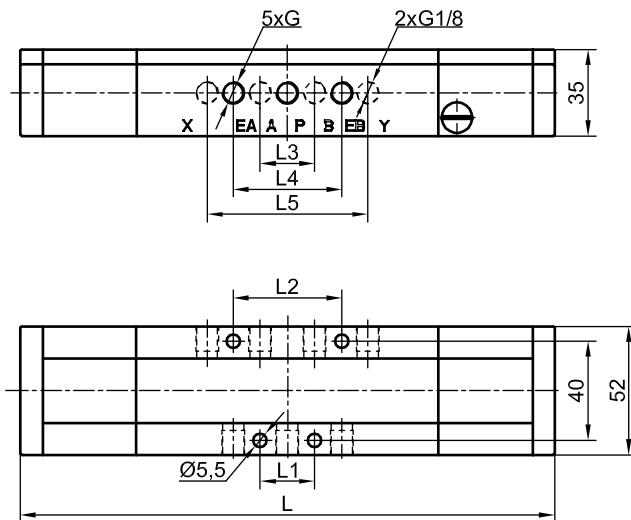
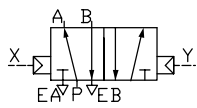

G	L	L1	L2	L3	L4	L5
G1/8	216	22	44	22	44	65
G1/4	240	32	62	32	64	90

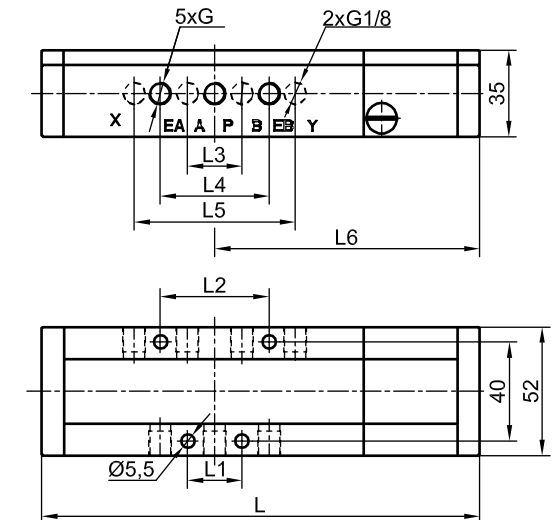
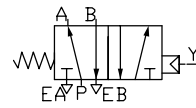

G	L	L1	L2	L3	L4	L5	L6
G1/8	177	22	44	22	44	65	107
G1/4	202	32	62	32	64	90	120

# DTP SERIES

Pneumatically operated distribution valves - wired



## VALVE DTP 5/2

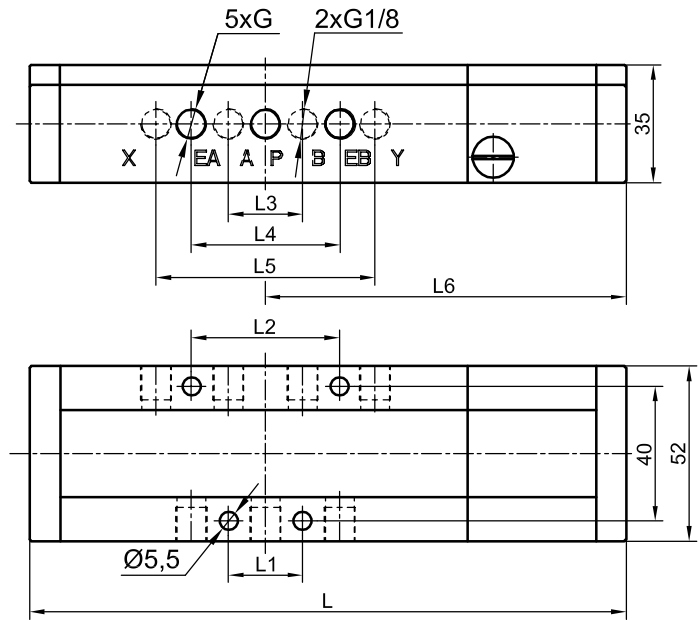
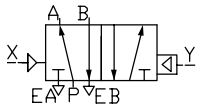

G	L	L1	L2	L3	L4	L5	L6
G1/8	216	22	44	22	44	65	107
G1/4	240	32	62	32	64	90	120

## VALVE DTP 5/3

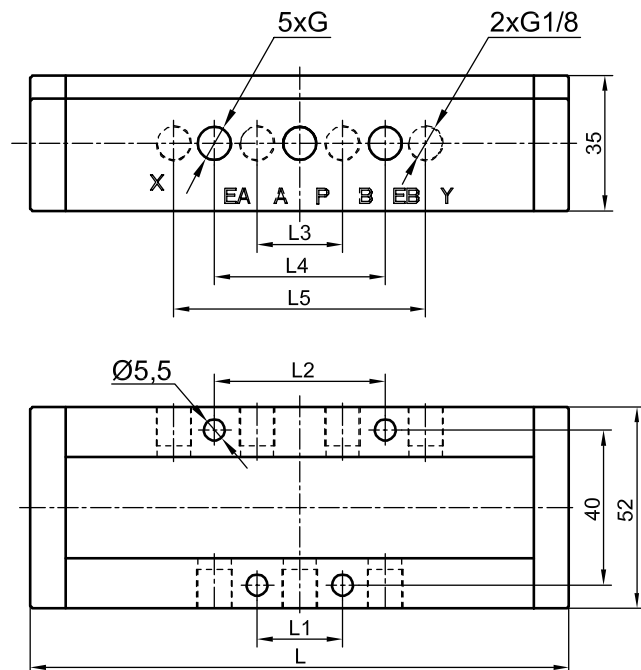

G	L	L1	L2	L3	L4	L5
G1/8	139	22	44	22	44	65
G1/4	164	32	62	32	64	90

### TECHNICAL SPECIFICATIONS

<b>Operating pressure range:</b>	according to the table
<b>Operating temperature range:</b>	0 to + 65°C
<b>Medium:</b>	compressed air, filtered, lubricated or non-lubricated
<b>Construction materials:</b>	<p><b>Body</b> - aluminium alloy</p> <p><b>Covers</b> - ZnAl alloy</p> <p><b>Slider</b> - aluminium alloy</p> <p><b>Seals</b> - polyurethane PU</p>



Number of paths / valve positions	Graphical symbol	Control type and operating pressure range	Con-nection thread	Nominal diameter	Order number	
					Valve	Subplate
3/2		pneumatic 2.0 — 10 bar	G1/4	Ø 7.5	23.0102.3214	25.0101.323314P
			G3/8	Ø 12	23.0102.3238	25.0101.323338P
			G1/2	Ø 16	23.0102.3212	25.0101.323312P
			G3/4	Ø 20	23.0102.3234	25.0101.323334P
		pneumatic, spring return 3.0 — 10 bar	G1/4	Ø 7.5	23.0104.3214	25.0101.323314P
			G3/8	Ø 12	23.0104.3238	25.0101.323338P
			G1/2	Ø 16	23.0104.3212	25.0101.323312P
			G3/4	Ø 20	23.0104.3234	25.0101.323334P
		pneumatic, with low pressure signal 1.5 — 10 bar	G1/4	Ø 7.5	23.0108.3214	25.0101.323314P
			G3/8	Ø 12	23.0108.3238	25.0101.323338P
			G1/2	Ø 16	23.0108.3212	25.0101.323312P
			G3/4	Ø 20	23.0108.3234	25.0101.323334P
	pneumatic with low-pressure signal, spring return 1.5 — 10 bar	G1/4	Ø 7.5	23.0110.3214	25.0101.323314P	
		G3/8	Ø 12	23.0110.3238	25.0101.323338P	
		G1/2	Ø 16	23.0110.3212	25.0101.323312P	
		G3/4	Ø 20	23.0110.3234	25.0101.323334P	
	pneumatic, with a differential piston	G1/4	Ø 7.5	23.0106.3214	25.0101.323314P	
		G3/8	Ø 12	23.0106.3238	25.0101.323338P	
		G1/2	Ø 16	23.0106.3212	25.0101.323312P	
		G3/4	Ø 20	23.0106.3234	25.0101.323334P	
3/3		pneumatic, in the middle position all paths cut off 3.0 — 10 bar	G1/4	Ø 7.5	23.0112.3314	25.0101.323314P
			G3/8	Ø 12	23.0112.3338	25.0101.323338P
			G1/2	Ø 16	23.0112.3312	25.0101.323312P
			G3/4	Ø 20	23.0112.3334	25.0101.323334P

# DTP SERIES

## Pneumatically operated distribution valves - for plate mounting



Number of paths / valve positions	Graphical symbol	Control type and operating pressure range	Con-nection thread	Nominal diameter	Order number		
					Valve	Subplate	
5/2		pneumatic 0.20 — 1.0 bar	G1/8	Ø 7.5	23.0102.521814	25.0102.525318P	
			G1/4			25.0102.525314P	
			G1/4		Ø 12	23.0102.521438	25.0103.525314P
			G3/8				25.0103.525338P
			G1/2			25.0104.525312P	
	G3/4	Ø 20	23.0102.521234	25.0104.525334P			
	G1/8			25.0102.525318P			
	G1/4		Ø 7.5	23.0104.521814	25.0102.525314P		
	G1/4				25.0103.525314P		
	G3/8			25.0103.525338P			
	G1/2	Ø 12	23.0104.521438	25.0104.525312P			
	G3/4			25.0104.525334P			
	G1/8		Ø 7.5	23.0108.521814	25.0102.525318P		
	G1/4	25.0102.525314P					
	G1/4	Ø 12		23.0108.521438	25.0103.525314P		
	G3/8				25.0103.525338P		
	G1/2			25.0104.525312P			
	G3/4	Ø 20	23.0108.521234	25.0104.525334P			
	G1/8			25.0102.525318P			
	G1/4		Ø 7.5	23.0110.521814	25.0102.525314P		
G1/4	25.0103.525314P						
G3/8	25.0103.525338P						
G1/2	Ø 12	23.0110.521438	25.0104.525312P				
G3/4			25.0104.525334P				
G1/8		Ø 7.5	23.0110.521234	25.0102.525318P			
G1/4	25.0102.525314P						
G1/4	Ø 12		23.0106.521814	25.0103.525314P			
G3/8				25.0103.525338P			
G1/2			25.0104.525312P				
G3/4	Ø 20	23.0106.521234	25.0104.525334P				
G1/8			25.0102.525318P				
G1/4		Ø 7.5	23.0112.531814	25.0102.525314P			
G1/4				25.0103.525314P			
G3/8			25.0103.525338P				
G1/2	Ø 12	23.0112.531438	25.0104.525312P				
G3/4			25.0104.525334P				
G1/8		Ø 7.5	23.114.531814	25.0102.525318P			
G1/4	25.0102.525314P						
G1/4	Ø 12		23.114.531438	25.0103.525314P			
G3/8				25.0103.525338P			
G1/2			25.0104.525312P				
G3/4	Ø 20	23.0114.531234	25.0104.525334P				
G1/8			25.0102.525318P				

### ORDERING PROCEDURE

In your order, please specify the name of the valve, number of paths/positions, connection thread, order number and the number of pieces, e.g.:

**Distribution valve 5/2 electromagnetically operated, spring return G3/8, for plate mounting, order number 22.0204.521438J 1 pc.**

## VALVE DTP 3/2

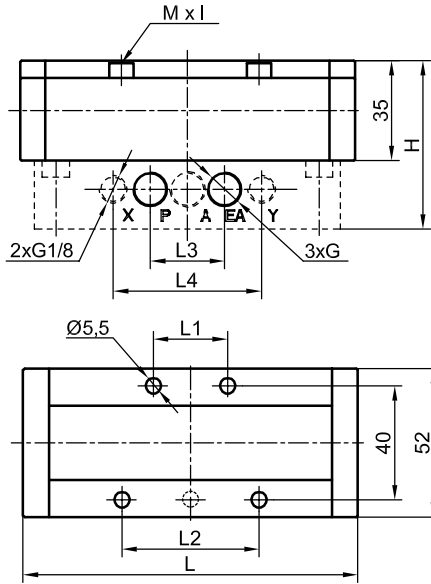
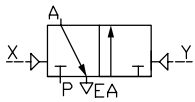

G	H	L	L1	L2	L3	L4	MxI
G1/4	59	117	26	48	26	52	M5x40-4pcs
G3/8	64	132	34	66	35	66	M5x40-4pcs
G1/2	69	147	39	81	48	88	M5x40-4pcs
G3/4	74	172	52	92	52	104	M5x50-5pcs

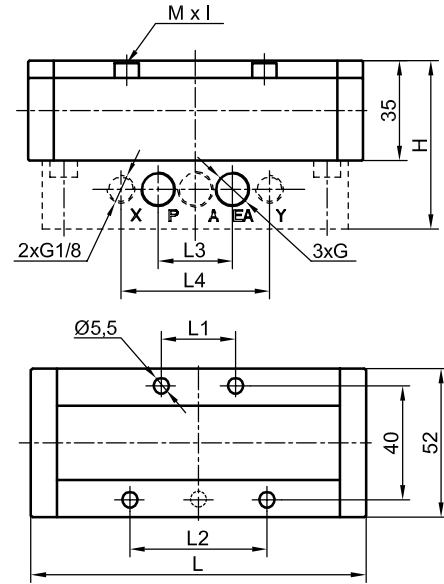
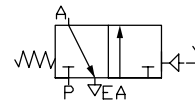

G	H	L	L1	L2	L3	L4	MxI
G1/4	59	117	26	48	26	52	M5x40-4pcs
G3/8	64	132	34	66	35	66	M5x40-4pcs
G1/2	69	147	39	81	48	88	M5x40-4pcs
G3/4	74	172	52	92	52	104	M5x50-5pcs

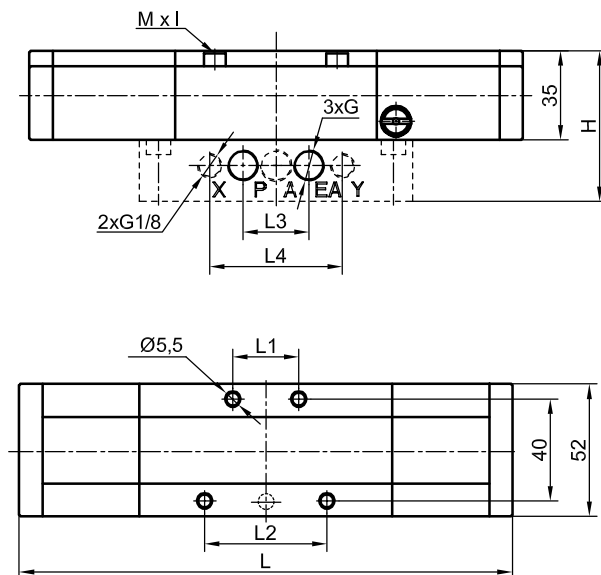
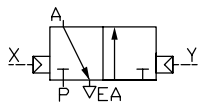

G	H	L	L1	L2	L3	L4	MxI
G1/4	59	193	26	48	26	52	M5x40-4pcs
G3/8	64	203	34	66	35	66	M5x40-4pcs
G1/2	69	243	39	81	48	88	M5x40-4pcs
G3/4	74	268	52	92	52	104	M5x50-5pcs

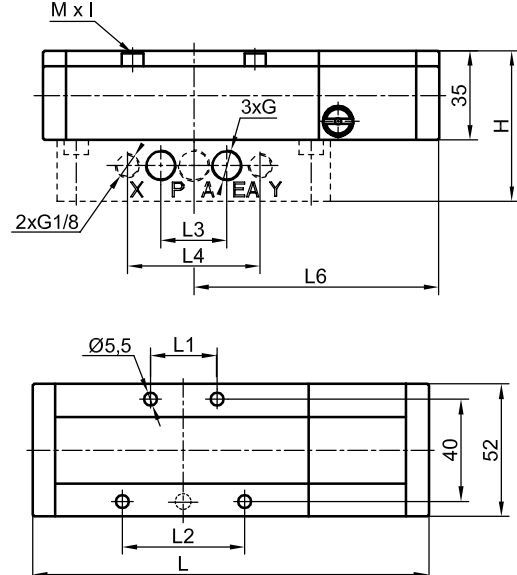
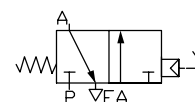

G	H	L	L1	L2	L3	L4	L6	MxI
G1/4	59	155	26	48	26	52	96	M5x40-4pcs
G3/8	64	170	34	66	35	66	104	M5x40-4pcs
G1/2	69	195	39	81	48	88	123	M5x40-4pcs
G3/4	74	220	52	92	52	104	134	M5x50-5pcs



# DTP SERIES

Pneumatically operated distribution valves - for plate mounting



## VALVE DTP 3/2

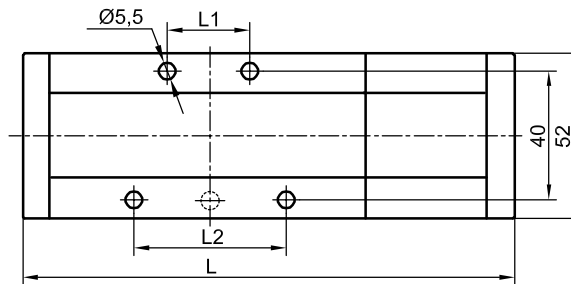
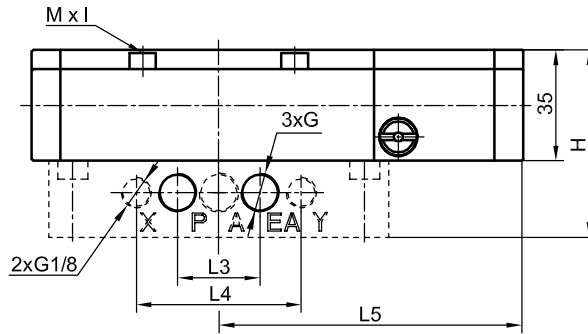
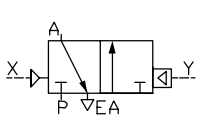

G	H	L	L1	L2	L3	L4	L5	MxI
G1/4	59	155	26	48	26	52	96	M5x40-4pcs
G3/8	64	170	34	66	35	66	104	M5x40-4pcs
G1/2	69	195	39	81	48	88	123	M5x40-4pcs
G3/4	74	220	52	92	52	104	134	M5x50-5pcs

## VALVE DTP 3/3

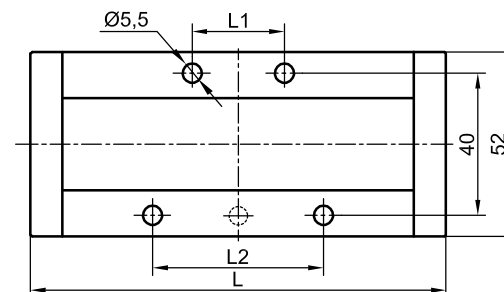
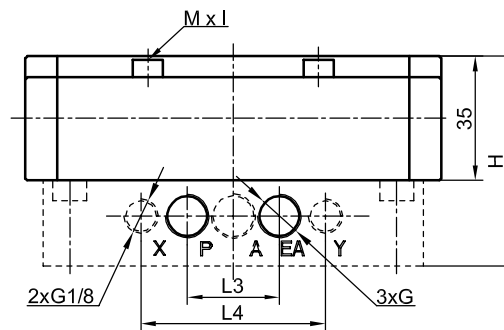
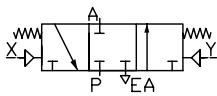

G	H	L	L1	L2	L3	L4	MxI
G1/4	59	117	26	48	26	52	M5x40-4pcs
G3/8	64	132	34	66	35	66	M5x40-4pcs
G1/2	69	147	39	81	48	88	M5x40-4pcs
G3/4	74	172	52	92	52	104	M5x50-5pcs

## VALVE DTP 5/2

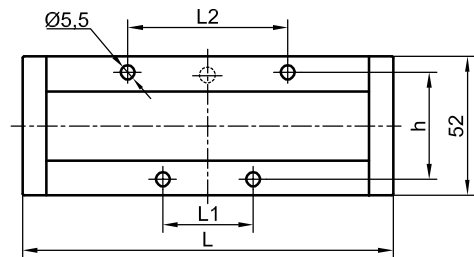
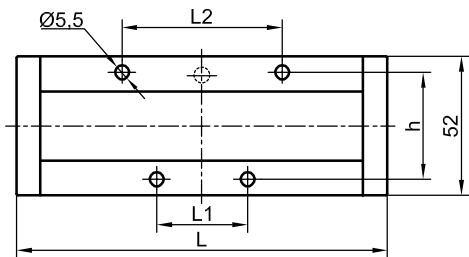
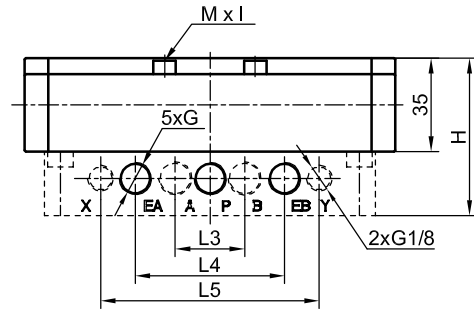
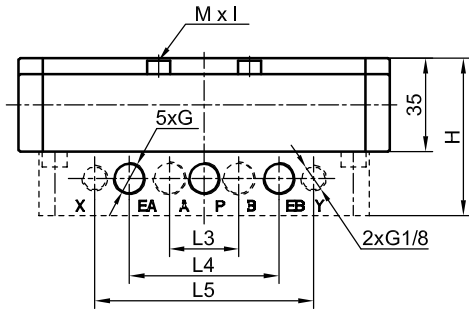
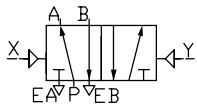

G	H	L	L1	L2	L3	L4	L5	h	Mxl
G1/8-G1/4	59	139	34	60	26	56	82	40	M5x40-4pcs
G1/4-G3/8	65	164	48	86	35	70	112	42	M5x40-4pcs
G1/2-G3/4	73	224	52	104	52	104	144	40	M6x40-5pcs

G	H	L	L1	L2	L3	L4	L5	h	Mxl
G1/8-G1/4	59	139	34	60	26	56	82	40	M5x40-4pcs
G1/4-G3/8	65	164	48	86	35	70	112	42	M5x40-4pcs
G1/2-G3/4	73	224	52	104	52	104	144	40	M6x40-5pcs

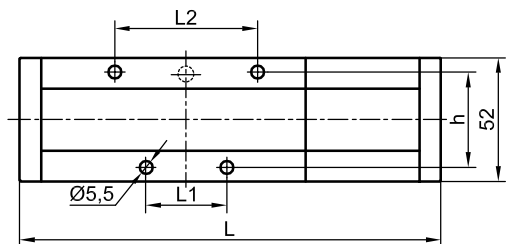
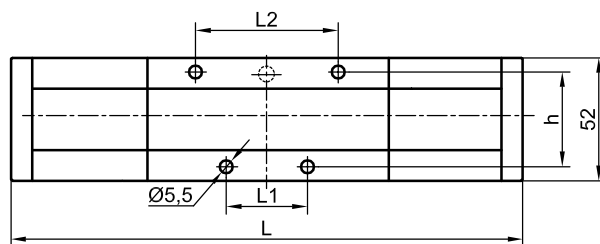
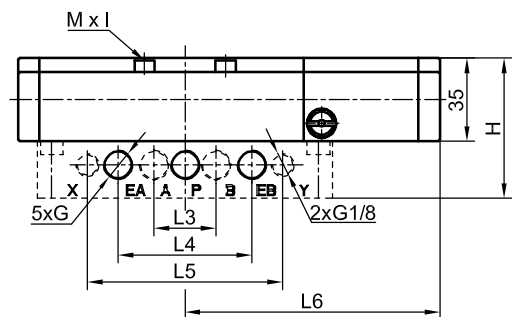
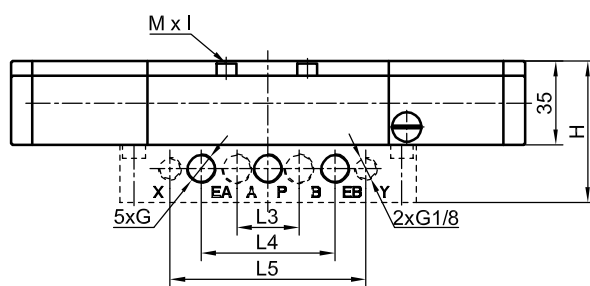
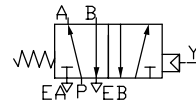
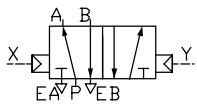

G	H	L	L1	L2	L3	L4	L5	h	Mxl
G1/8-G1/4	59	215	34	60	26	56	82	40	M5x40-4pcs
G1/4-G3/8	65	240	48	86	35	70	112	42	M5x40-4pcs
G1/2-G3/4	73	320	52	104	52	104	144	40	M6x40-5pcs

G	H	L	L1	L2	L3	L4	L5	L6	h	Mxl
G1/8-G1/4	59	177	34	60	26	56	82	107	40	M5x40-4pcs
G1/4-G3/8	65	202	48	86	35	70	112	120	42	M5x40-4pcs
G1/2-G3/4	73	272	52	104	52	104	144	160	40	M6x40-5pcs

# DTP SERIES

Pneumatically operated distribution valves - for plate mounting



## VALVE DTP 5/2

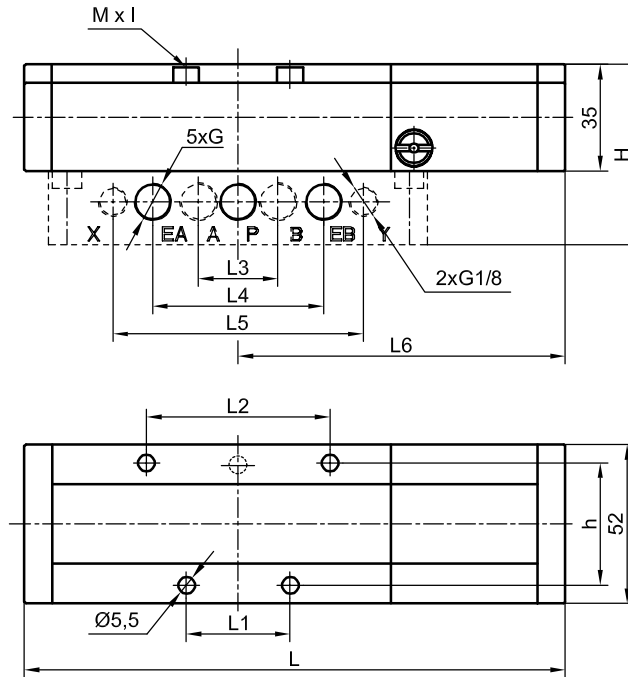
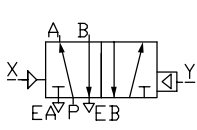

G	H	L	L1	L2	L3	L4	L5	L6	h	Mxl
G1/8-G1/4	59	177	34	60	26	56	82	107	40	M5x40-4pcs
G1/4-G3/8	65	202	48	86	35	70	112	120	42	M5x40-4pcs
G1/2-G3/4	73	272	52	104	52	104	144	160	40	M6x40-5pcs

## VALVE DTP 5/3

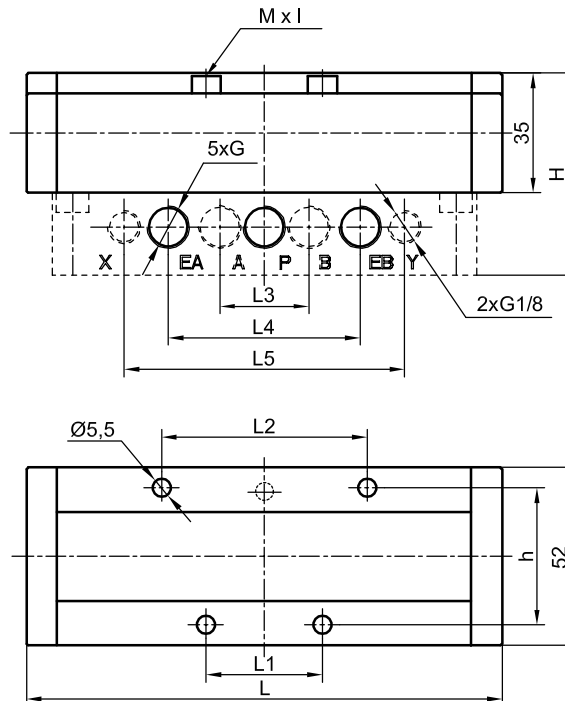
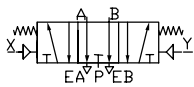
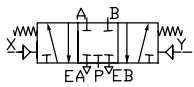

G	H	L	L1	L2	L3	L4	L5	h	Mxl
G1/8-G1/4	59	139	34	60	26	56	82	40	M5x40-4pcs
G1/4-G3/8	65	164	48	86	35	70	112	42	M5x40-4pcs
G1/2-G3/4	73	224	52	104	52	104	144	40	M6x40-5pcs

## TECHNICAL SPECIFICATIONS

<b>Operating pressure range:</b>	2.0 — 10 bar
<b>Operating temperature range:</b>	0 to + 65°C
<b>Medium:</b>	compressed air, filtered, lubricated
<b>Construction materials:</b>	<p><b>Body</b> - aluminium alloy</p> <p><b>Slider</b> - aluminium alloy</p> <p><b>Seals</b> - polyurethane PU</p>



The two-hand control block is used in pneumatic control systems where a risk is present for personnel during the manual operation of a machine, e.g. a press.

The valve is operated by simultaneously receiving input signals P1 and P2.

If one of them is missing, the valve will return to its initial position and the output signal A will fade.

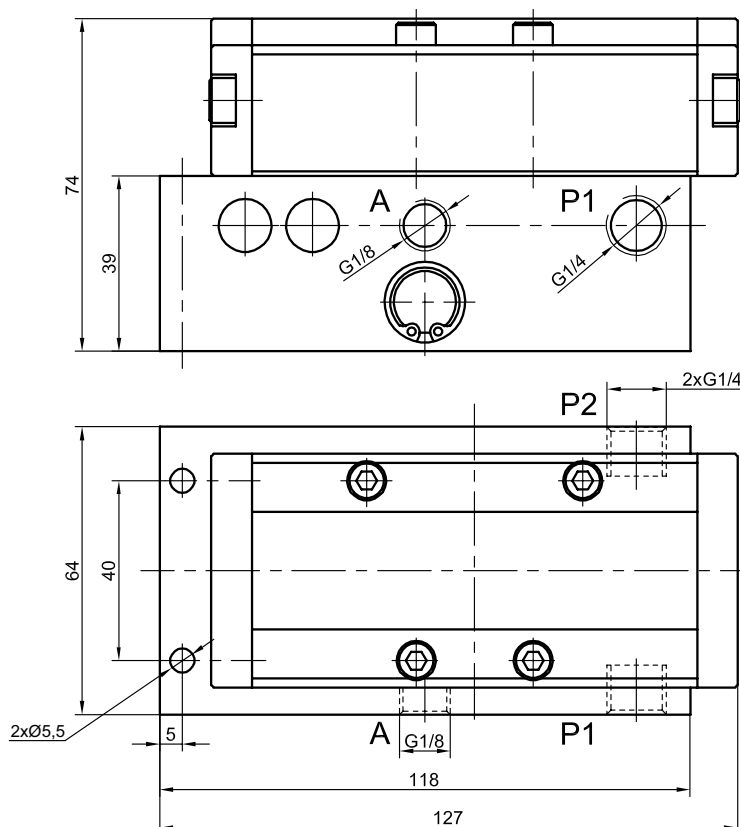

## GRAPHIC DIAGRAM

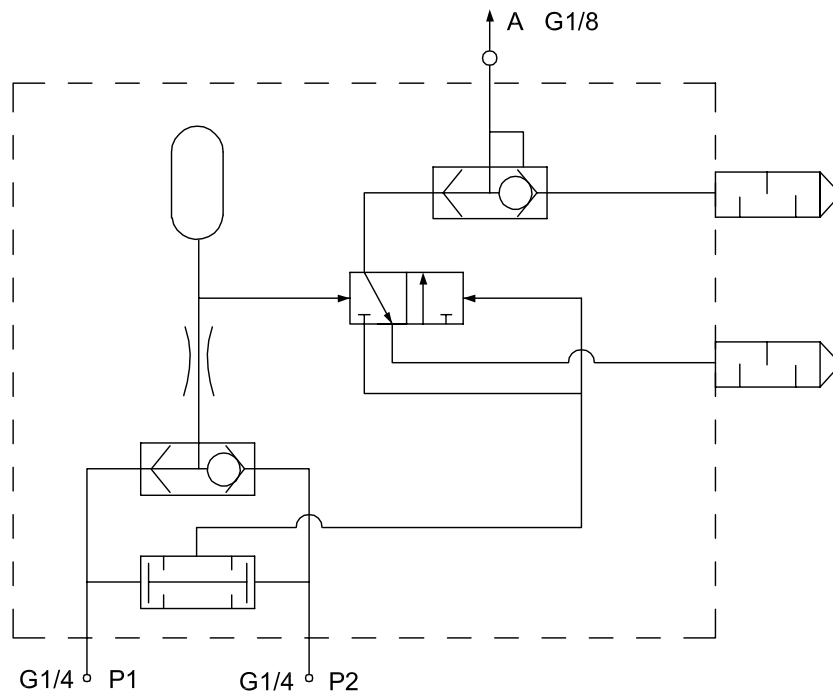

<b>Order number</b>	90.0011.18
---------------------	------------

## ORDERING PROCEDURE

In your order, please specify: name, connection thread, order number and the number of pieces, e.g.:

**Two-hand control block G1/8 no. 90.0011.18 1 pc.**

## TECHNICAL SPECIFICATIONS

<b>Operating pressure range:</b>	2.5 — 10 bar
<b>Operating temperature range:</b>	0 to + 65°C
<b>Medium:</b>	compressed air, filtered, lubricated or non-lubricated
<b>Construction materials:</b>	<p><b>Body</b> - aluminium alloy</p> <p><b>Subplate</b> - aluminium alloy</p> <p><b>Slider</b> - stainless steel</p> <p><b>Seals</b> - polyurethane PU</p>



Number of paths / valve positions	Graphical symbol	Control type and operating pressure range	Connection thread	Nominal diameter	Order number	
					Valve	Subplate
5/2		pneumatic 2.5 — 10 bar	G1/8	Ø 5	<b>28.0027.5218</b>	<b>28.2525.5218</b>
		pneumatic, spring return 2.5 — 10 bar			<b>28.0025.5218</b>	<b>28.2525.5218</b>

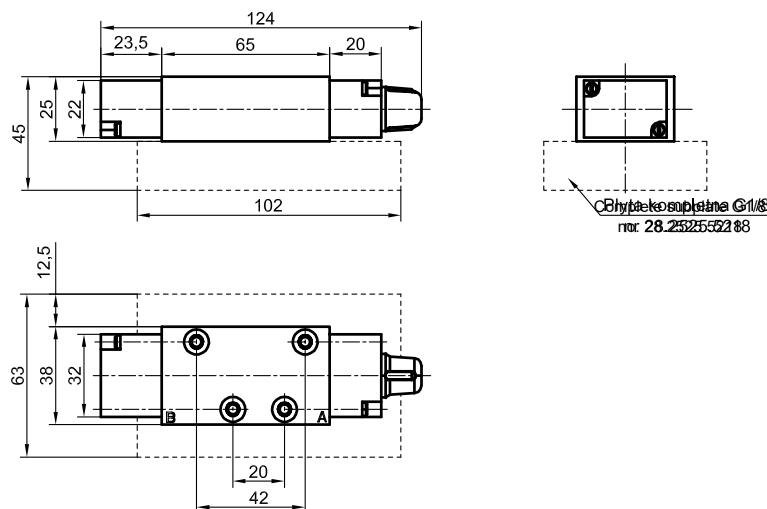

## ORDERING PROCEDURE

In your order, please specify: name, number of paths / positions, connection thread, order number and number of pieces, e.g.:

**Distribution valve 5/2 G1/8 pneumatically operated, spring return,  
no. 28.0025.5218 1 pc., with subplate No. 28.2525.5218 1 pc.**



### TECHNICAL SPECIFICATIONS

<b>Operating pressure range:</b> 0 — 10 bar
<b>Operating temperature range:</b> 0 to + 65°C
<b>Medium:</b> compressed air, filtered, lubricated
<b>Construction materials:</b>
<b>Body</b> - aluminium alloy
<b>Covers</b> - ZnAl alloy
<b>Slider</b> - aluminium alloy
<b>Seals</b> - nitrile-butadiene rubber (NBR)



Number of paths / valve positions	Graphical symbol	Control type and operating pressure range	Connection thread	Nominal diameter	Order number
3/2		lever, spring return 0 — 10 bar	G1/8	Ø 5	<b>24.0509.3218</b>
			G1/4	Ø 7.5	<b>24.0509.3214</b>
		lever, locking with a latch 0 — 10 bar	G1/8	Ø 5	<b>24.0510.3218</b>
			G1/4	Ø 7.5	<b>24.0510.3214</b>
		lever, locking with a latch, vertical 0 — 10 bar	G1/8	Ø 5	<b>24.0511.3218</b>
			G1/4	Ø 7.5	<b>24.0511.3214</b>
5/2		lever, spring return 0 — 10 bar	G1/8	Ø 5	<b>24.0509.5218</b>
			G1/4	Ø 7.5	<b>24.0509.5214</b>
		lever, locking with a latch 0 — 10 bar	G1/8	Ø 5	<b>24.0510.5218</b>
			G1/4	Ø 7.5	<b>24.0510.5214</b>
		lever, locking with a latch, vertical 0 — 10 bar	G1/8	Ø 5	<b>24.0511.5218</b>
			G1/4	Ø 7.5	<b>24.0511.5214</b>



# TM SERIES

## Manual lever operated distribution valves - wired



Number of paths / valve positions	Graphical symbol	Control type and operating pressure range	Connection thread	Nominal diameter	Order number
5/3		lever, locking with a latch, in the middle position all paths cut off 0 — 10 bar	G1/8	Ø 5	<b>24.0514.5318</b>
			G1/4	Ø 7.5	<b>24.0514.5314</b>
		lever, locking with a latch, in the middle position all paths vented 0 — 10 bar	G1/8	Ø 5	<b>24.0515.5318</b>
			G1/4	Ø 7.5	<b>24.0515.5314</b>
		lever, locking with a latch, in the middle position all paths connected to the supply 0 — 10 bar	G1/8	Ø 5	<b>24.0516.5318</b>
			G1/4	Ø 7.5	<b>24.0516.5314</b>
		lever, spring-centred, in the middle position all paths cut off 0 — 10 bar	G1/8	Ø 5	<b>24.0517.5318</b>
			G1/4	Ø 7.5	<b>24.0517.5314</b>
		lever, spring-centred, in the middle position all paths vented 0 — 10 bar	G1/8	Ø 5	<b>24.0518.5318</b>
			G1/4	Ø 7.5	<b>24.0518.5314</b>
		lever, spring-centred, in the middle position all paths connected to the supply 0 — 10 bar	G1/8	Ø 5	<b>24.0519.5318</b>
			G1/4	Ø 7.5	<b>24.0519.5314</b>

### ORDERING PROCEDURE

In your order, please specify: name, number of paths / positions, connection thread, order number and number of pieces, e.g.:

**Distribution valve 3/2 G1/8, manual lever operated, no. 24.0401.4338 1 pc.**

### VALVE TM 3/2 G1/8

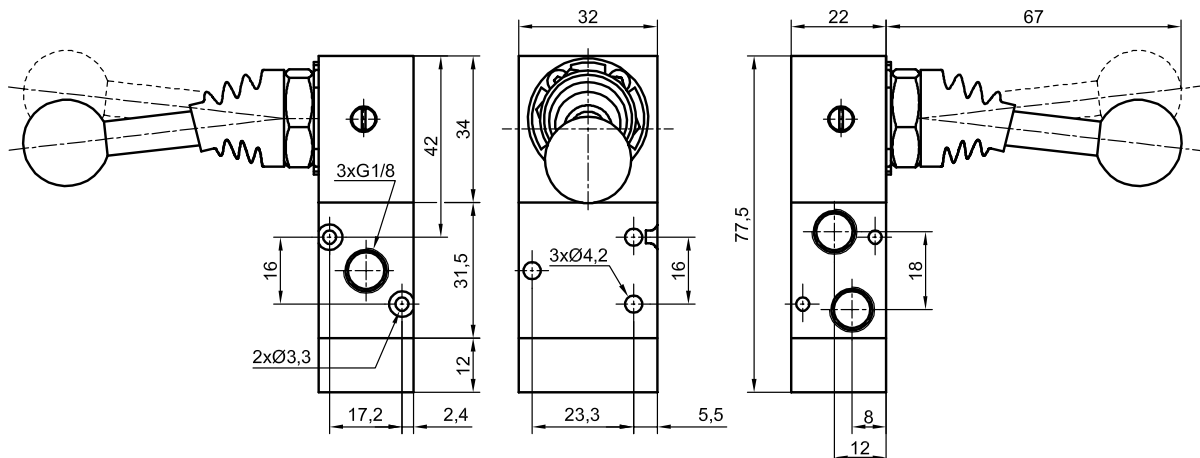
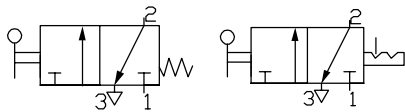

## VALVE TM 3/2 G1/8

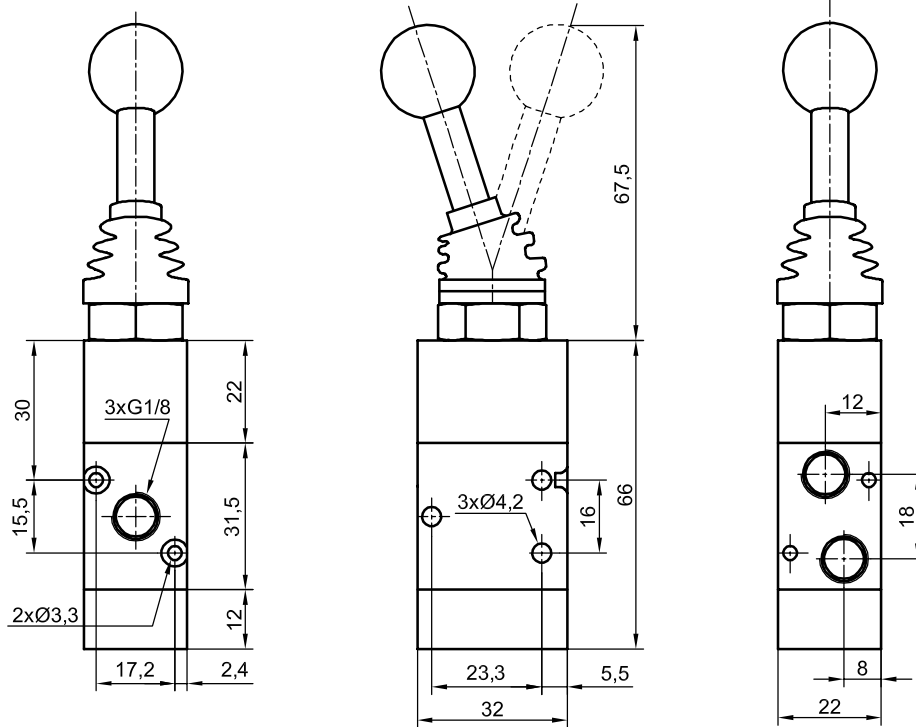
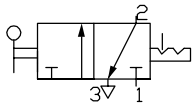

## VALVE TM 3/2 G1/4

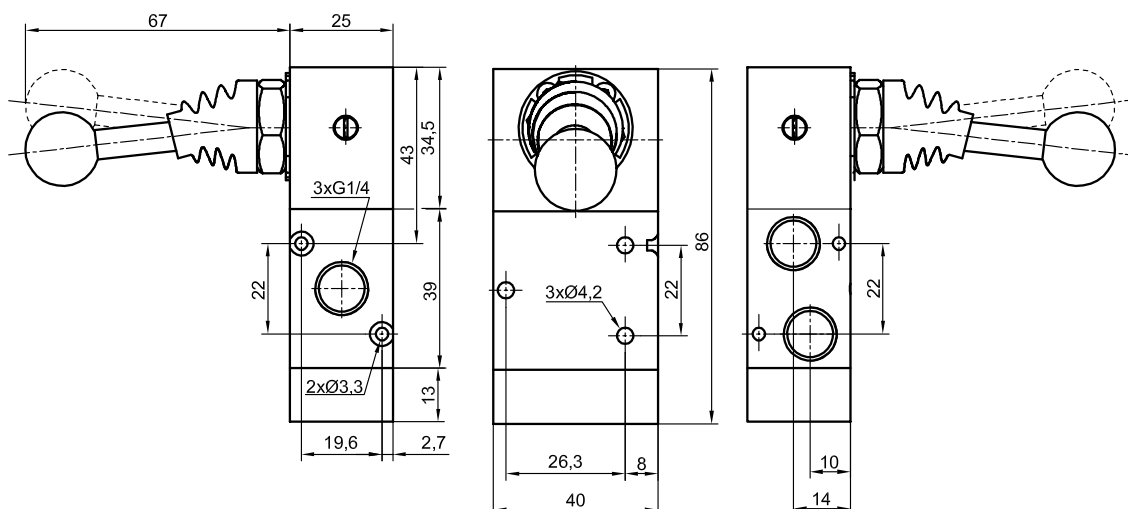
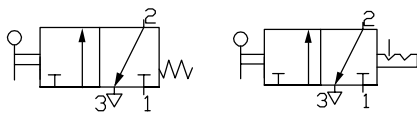

# TM SERIES

Manual lever operated  
distribution valves - wired



## VALVE TM 3/2 G1/4

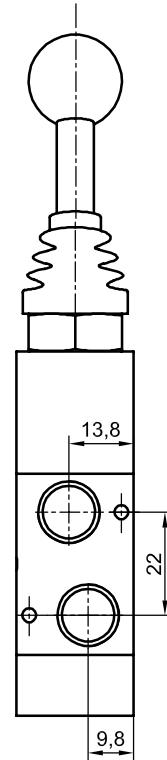
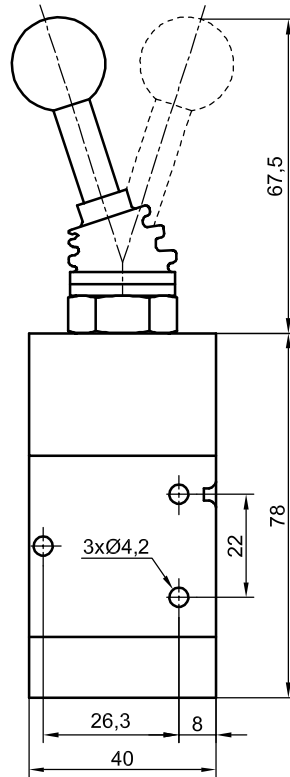
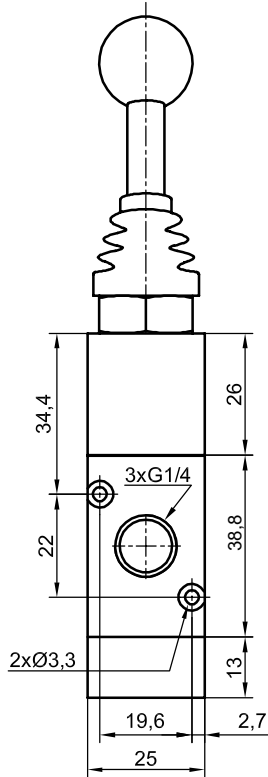
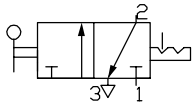

## VALVE TM 5/2 G1/8

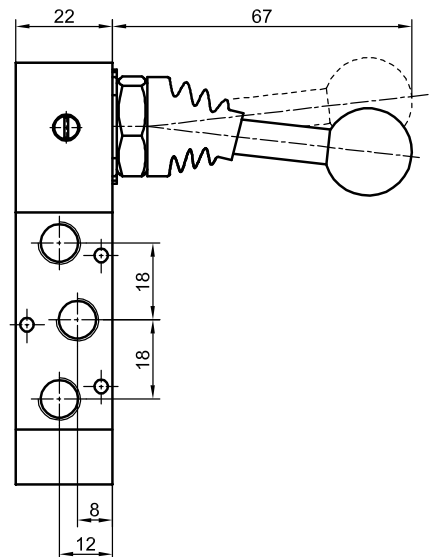
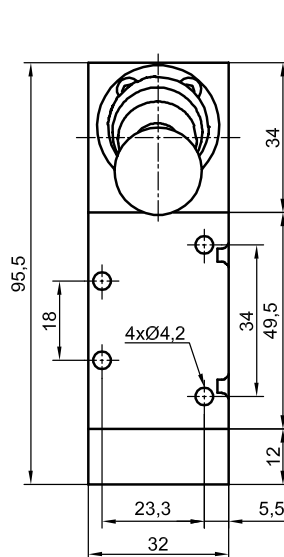
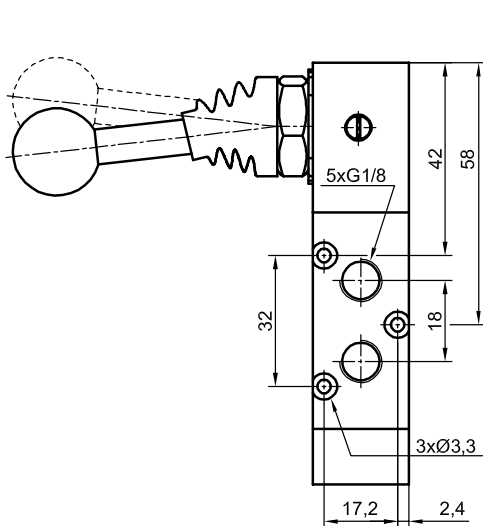
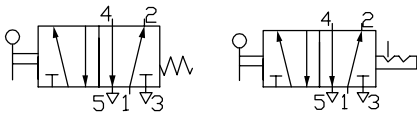

## VALVE TM 5/2 G1/4

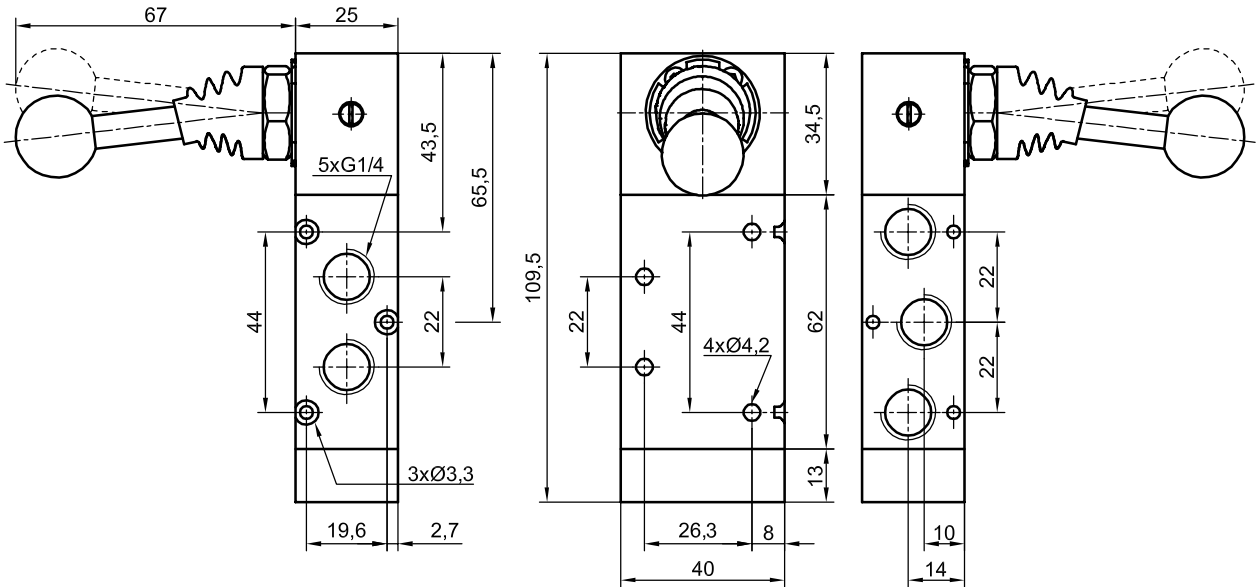
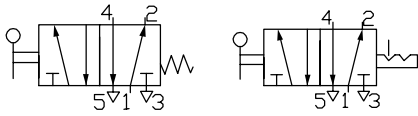

## VALVE TM 5/2 G1/8

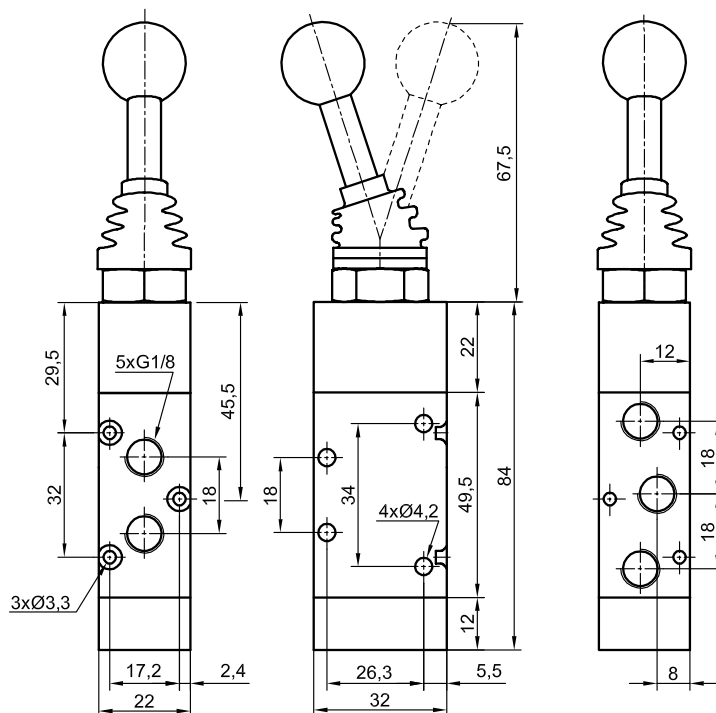
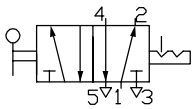

# TM SERIES

Manual lever operated  
distribution valves - wired



## VALVE TM 5/2 G1/4

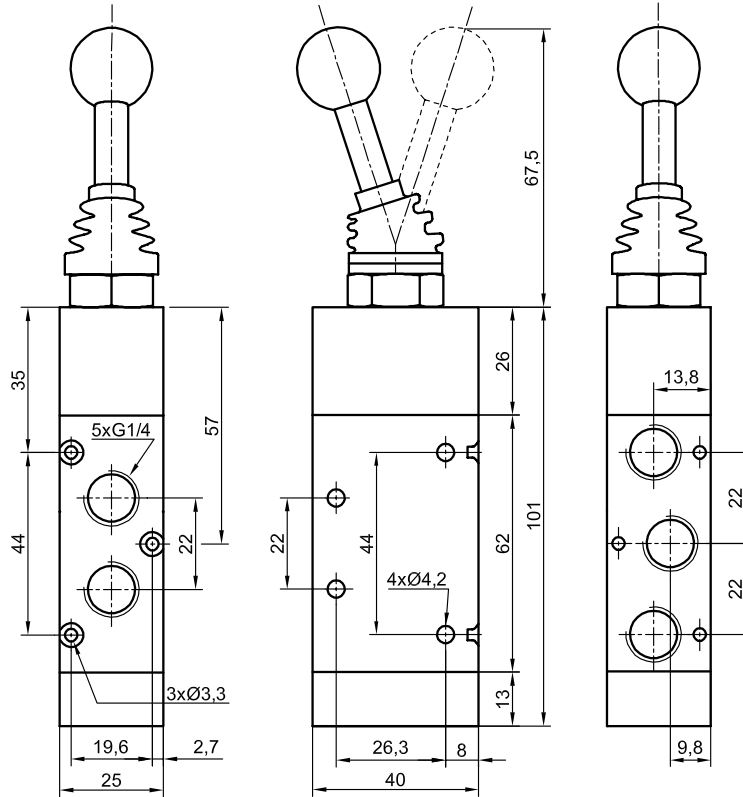
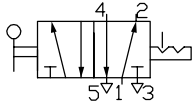

## VALVE TM 5/3 G1/8

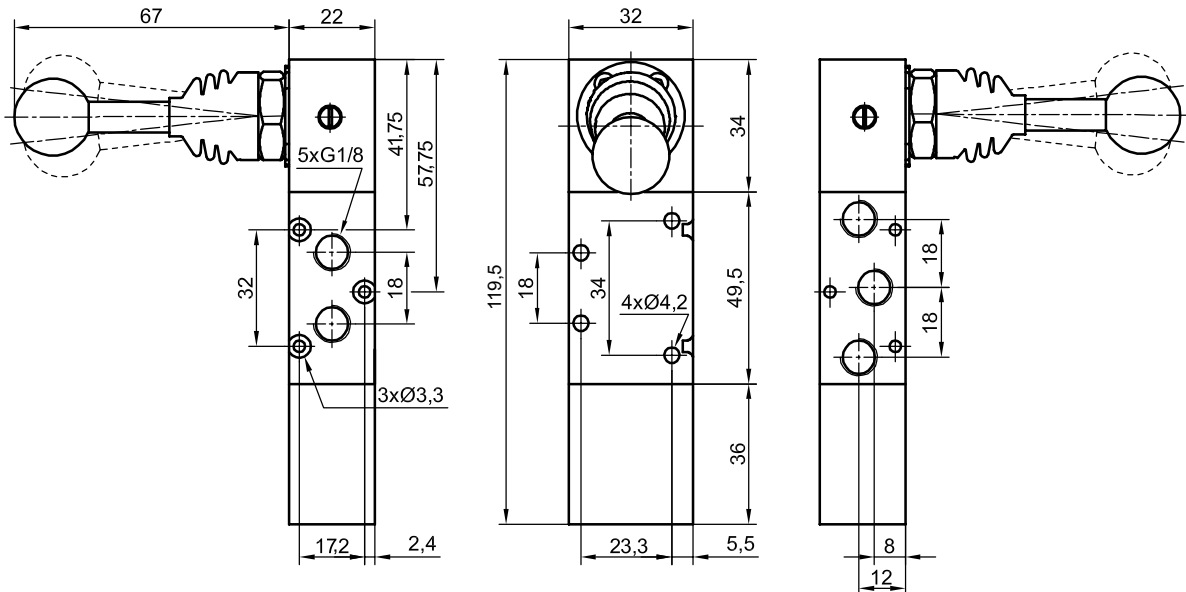
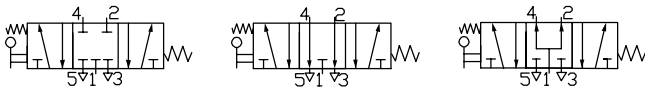

## VALVE TM 5/3 G1/4

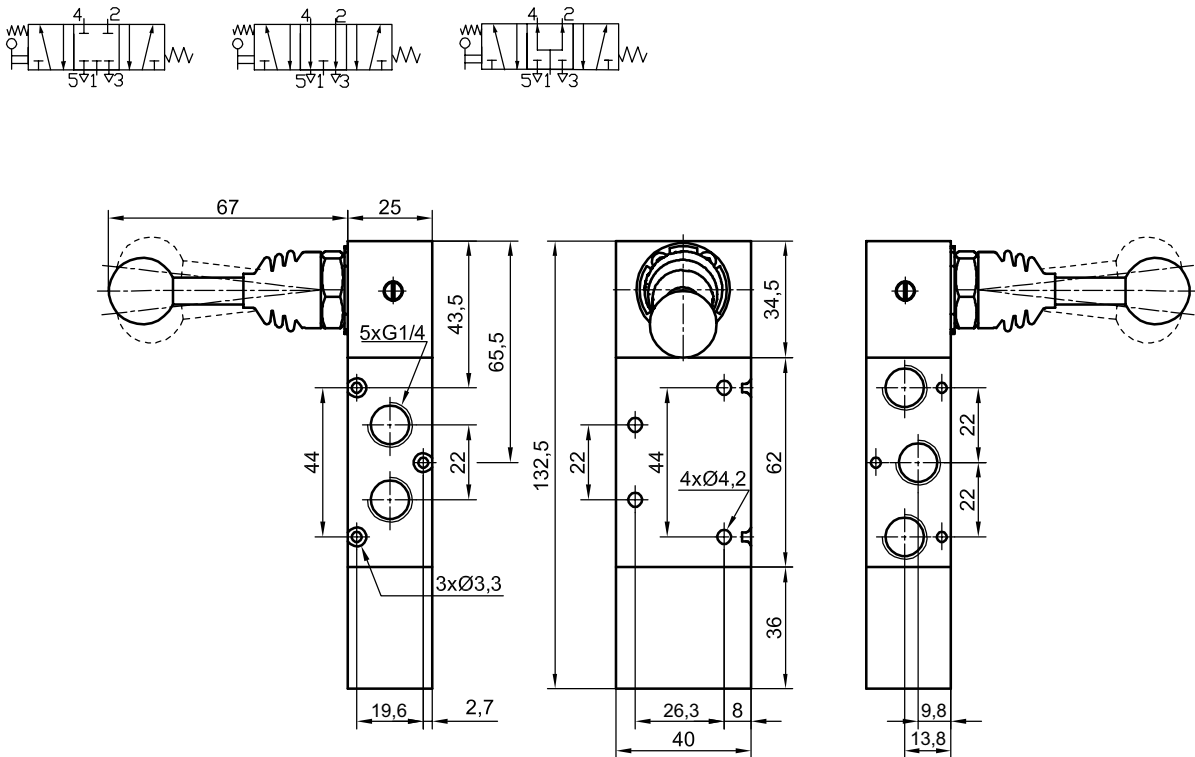

## VALVE TM 5/3 G1/8

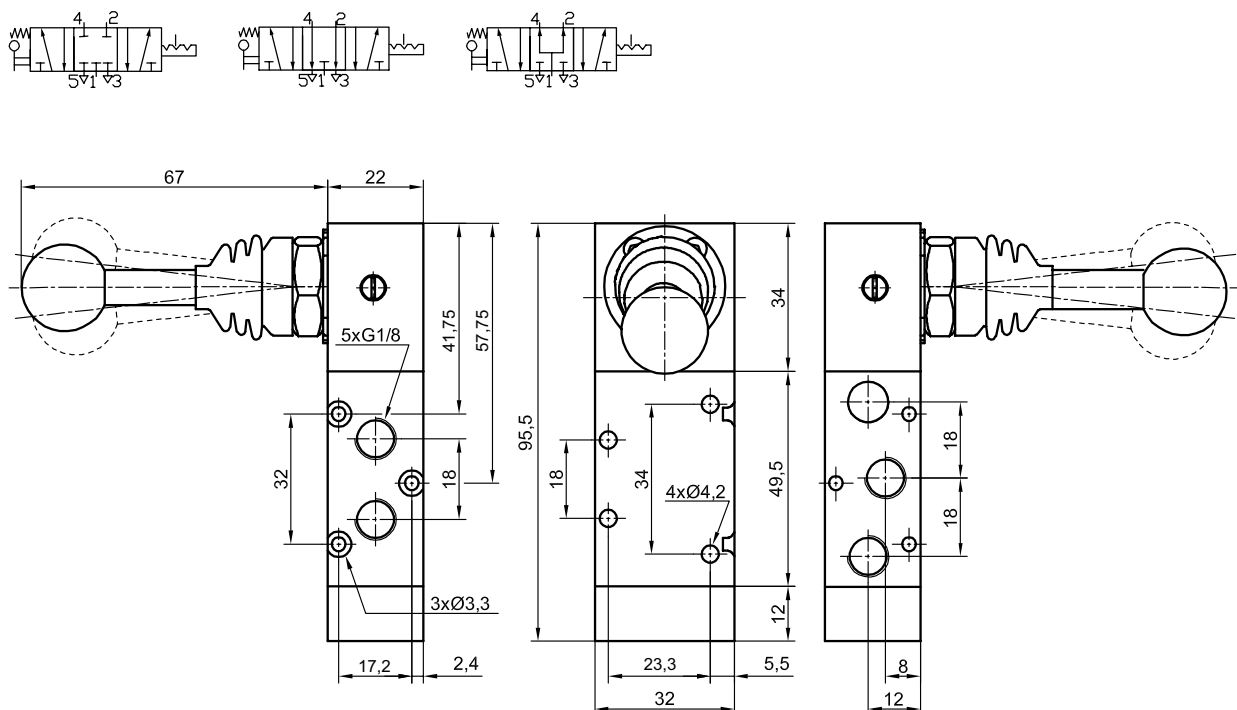

# TM SERIES

Manual lever operated  
distribution valves - wired



## VALVE TM 5/3 G1/4

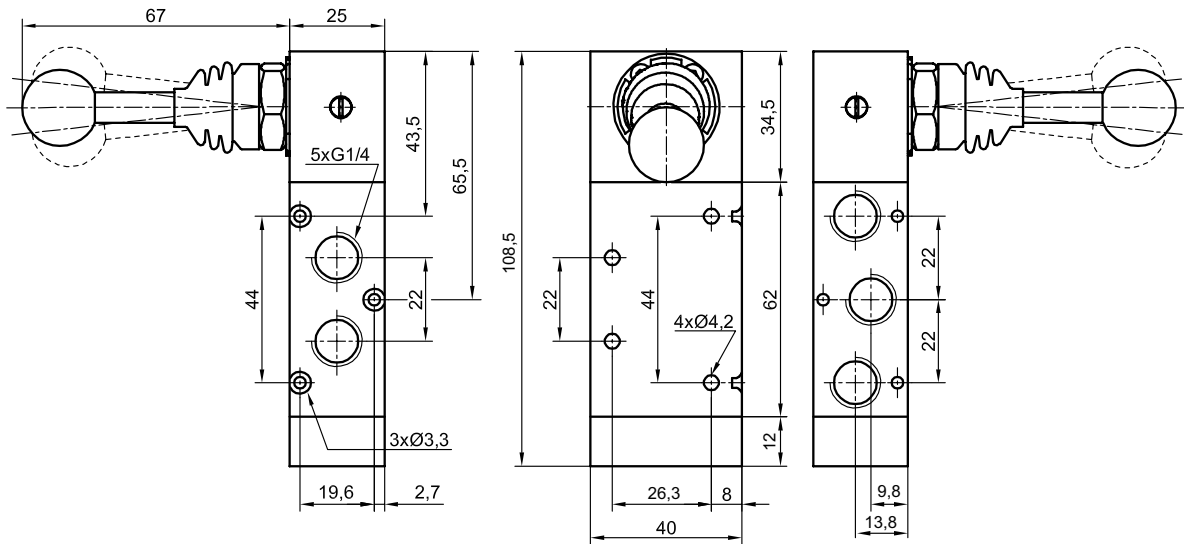
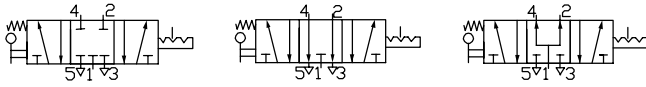

### TECHNICAL SPECIFICATIONS

<b>Operating pressure range:</b>	0 — 10 bar
<b>Operating temperature range:</b>	0 to + 65°C
<b>Medium:</b>	compressed air, filtered, lubricated
<b>Construction materials:</b>	<p><b>Body</b> - aluminium alloy</p> <p><b>Covers</b> - ZnAl alloy</p> <p><b>Slider</b> - aluminium alloy</p> <p><b>Seals</b> - polyurethane PU</p>



Number of paths / valve positions	Graphical symbol	Control type and operating pressure range	Connection thread	Order number
3/2		pull rod 0 — 10 bar	G1/8	<b>24.0101.3218</b>
			G1/4	<b>24.0101.3214</b>
		pull rod, spring return 0 — 10 bar	G1/8	<b>24.0103.3218</b>
			G1/4	<b>24.0103.3214</b>
		lever 0 — 10 bar	G1/8	<b>24.0107.3218</b>
			G1/4	<b>24.0107.3214</b>
3/2		lever, spring return 0 — 10 bar	G1/8	<b>24.0109.3218</b>
			G1/4	<b>24.0109.3214</b>
		rollers 0 — 10 bar	G1/8	<b>24.0121.3218</b>
			G1/4	<b>24.0121.3214</b>
		roller, spring return 0 — 10 bar	G1/8	<b>24.0123.3218</b>
			G1/4	<b>24.0123.3214</b>
3/3		lever, locking with a latch, in the middle position all paths cut off 0 — 10 bar	G1/8	<b>24.0111.3318</b>
			G1/4	<b>24.0111.3314</b>
		lever, locking with springs, in the middle position all paths cut off 0 — 10 bar	G1/8	<b>24.0117.3318</b>
			G1/4	<b>24.0127.3314</b>



# DTM SERIES

Manual pull rod, lever, roller operated  
distribution valves - wired



5/2		pull rod 0 — 10 bar	G1/8	<b>24.0101.5218</b>
			G1/4	<b>24.0101.5214</b>
		pull rod, spring return 0 — 10 bar	G1/8	<b>24.0103.5218</b>
			G1/4	<b>24.0103.5214</b>
		lever 0 — 10 bar	G1/8	<b>24.0107.5218</b>
			G1/4	<b>24.0107.5214</b>
		lever, spring return 0 — 10 bar	G1/8	<b>24.0109.5218</b>
			G1/4	<b>24.0109.5214</b>
		rollers 0 — 10 bar	G1/8	<b>24.0121.5218</b>
			G1/4	<b>24.0121.5214</b>
		roller, spring return 0 — 10 bar	G1/8	<b>24.0123.5218</b>
			G1/4	<b>24.0123.5214</b>
5/3		lever, locking with a latch, in the middle position all paths vented 0 — 10 bar	G1/8	<b>24.0113.5318</b>
			G1/4	<b>24.0113.5314</b>
		lever, locking with a latch, in the middle position all paths cut off 0 — 10 bar	G1/8	<b>24.0115.5318</b>
			G1/4	<b>24.0115.5314</b>
		lever, locking with springs, in the middle position all paths vented 0 — 10 bar	G1/8	<b>24.0119.5318</b>
			G1/4	<b>24.0119.5314</b>
		lever, locking with springs, in the middle position all paths cut off 0 — 10 bar	G1/8	<b>24.0117.5318</b>
			G1/4	<b>24.0117.5314</b>

## ORDERING PROCEDURE

In your order, please specify the name and function of the valve, connection thread,  
order number and the number of pieces, e.g.:

**Distribution valve 3/2 G1/8 pull rod operated, spring return, wired no. 24.0103.3218 1 pc.**

## VALVE DTM 3/2

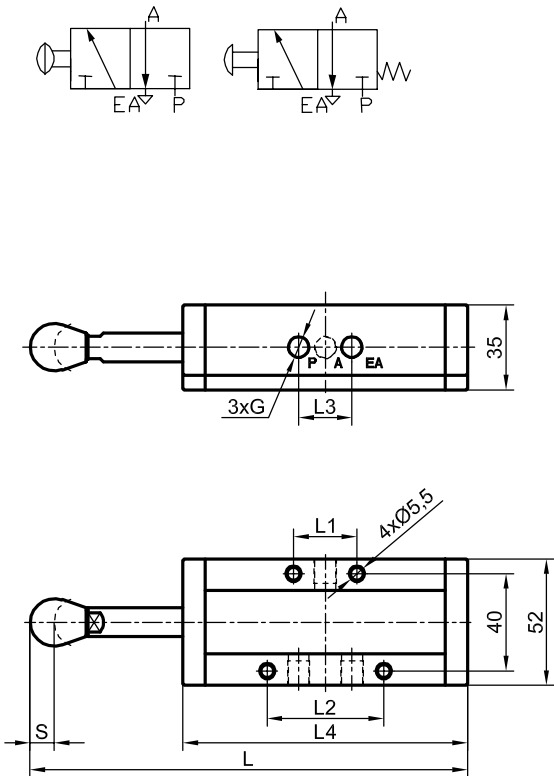

G	L	L1	L2	L3	L4	S
G1/8	180	26	48	22	117	10
G1/4	200	34	66	32	132	15

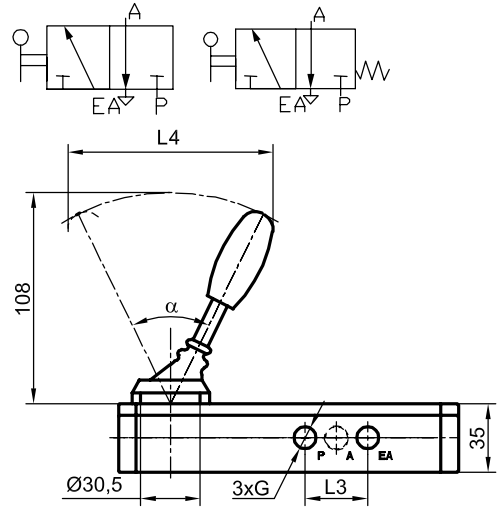

G	L	L1	L2	L3	L4	L5	α
G1/8	159	26	48	22	72	76	26
G1/4	174	34	66	32	96	85	36

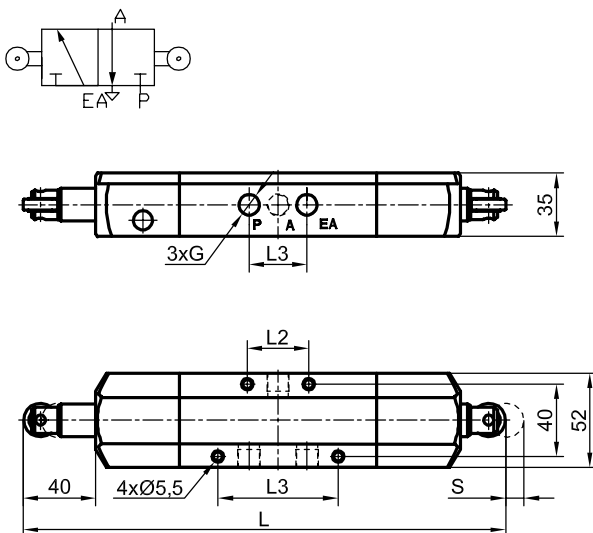

G	L	L1	L2	L3	S
G1/8	256	26	48	22	10
G1/4	266	34	66	32	15

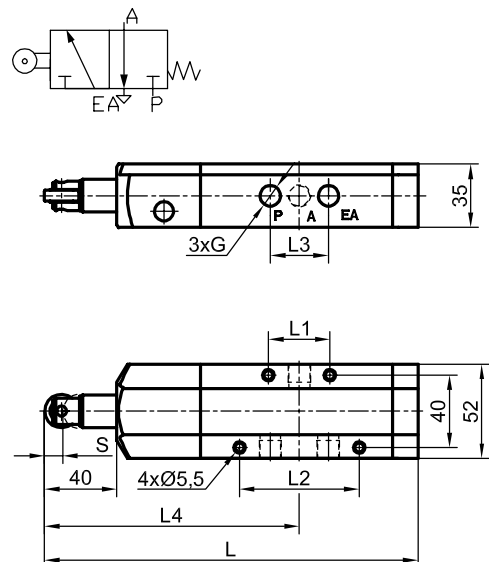

G	L	L1	L2	L3	L4	S
G1/8	191	26	48	22	133	10
G1/4	206	34	66	32	140	15

# DTM SERIES

Manual pull rod, lever, roller operated distribution valves - wired



## VALVE DTM 3/3

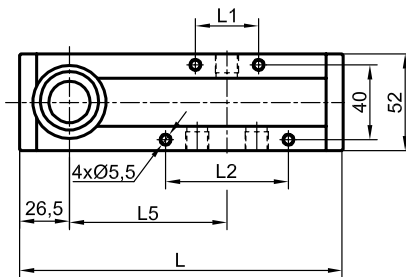
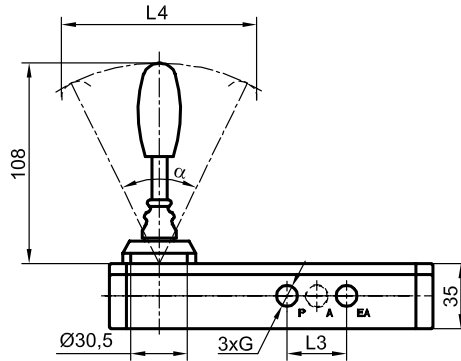
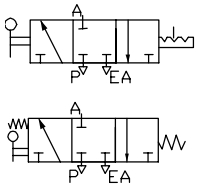

G	L	L1	L2	L3	L4	L5	$\alpha$
G1/8	159	26	48	22	72	76	26
G1/4	174	34	66	32	96	85	36

## VALVE DTM 5/2

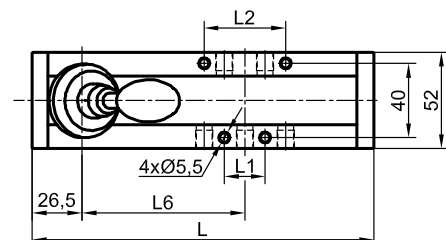
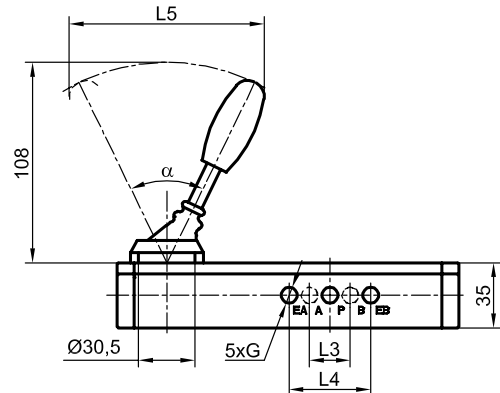
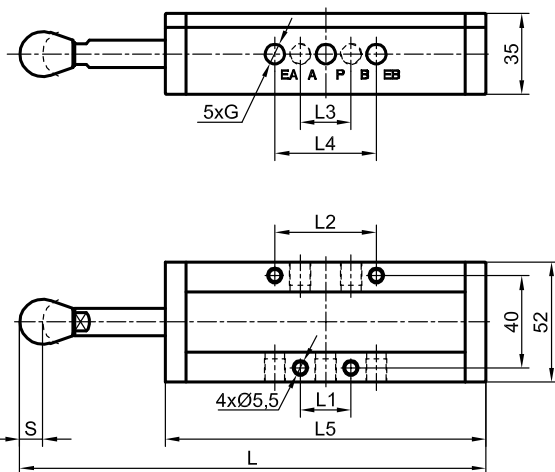
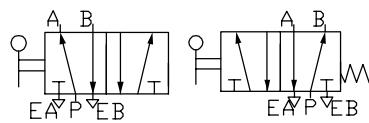
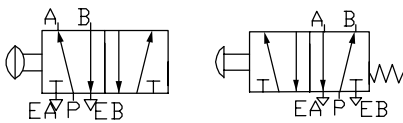

G	L	L1	L2	L3	L4	L5	S
G1/8	202	22	44	22	44	139	10
G1/4	232	32	62	32	64	164	15

G	L	L1	L2	L3	L4	L5	L6	$\alpha$
G1/8	184	22	44	22	44	72	88	26
G1/4	209	32	62	32	64	96	100	36

## VALVE DTM 5/2

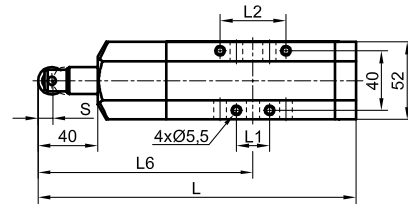
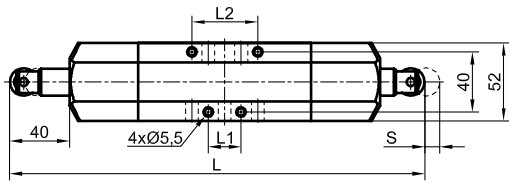
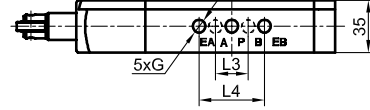
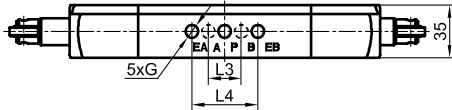
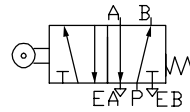
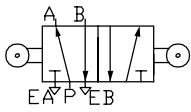

G	L	L1	L2	L3	L4	S
G1/8	278	22	44	22	44	10
G1/4	298	32	62	32	64	15

G	L	L1	L2	L3	L4	L6	S
G1/8	213	22	44	22	44	144	10
G1/4	238	32	62	32	64	156	15

## VALVE DTM 5/3

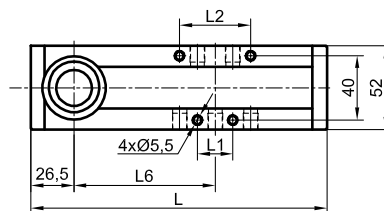
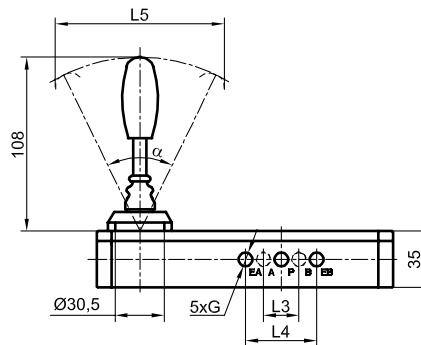
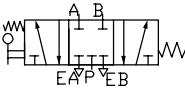
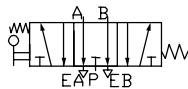
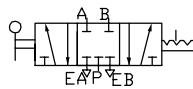
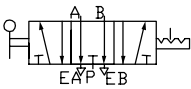

G	L	L1	L2	L3	L4	L5	L6	$\alpha$
G1/8	184	22	44	22	44	72	88	26
G1/4	209	32	62	32	64	96	100	36



## TECHNICAL SPECIFICATIONS

<b>Operating pressure range:</b>	0 — 10 bar
<b>Operating temperature range:</b>	0 to + 65°C
<b>Medium:</b>	compressed air, filtered, lubricated
<b>Construction materials:</b>	<p><b>Body</b> - aluminium alloy</p> <p><b>Covers</b> - ZnAl alloy</p> <p><b>Slider</b> - aluminium alloy</p> <p><b>Seals</b> - polyurethane PU</p>



Number of paths / valve positions	Graphical symbol	Control type and operating pressure range	Connection thread	Order number
3/2		pull rod 0 — 10 bar	G1/8	<b>24.0105.3218</b>
			G1/4	<b>24.0105.3214</b>
		pull rod, spring return 0 — 10 bar	G1/8	<b>24.0106.3218</b>
			G1/4	<b>24.0106.3214</b>
5/2		pull rod 0 — 10 bar	G1/8	<b>24.0105.5218</b>
			G1/4	<b>24.0105.5214</b>
		pull rod, spring return 0 — 10 bar	G1/8	<b>24.0106.5218</b>
			G1/4	<b>24.0106.5214</b>

## ORDERING PROCEDURE

In your order, please specify the name and function of the valve, connection thread, order number and the number of pieces, e.g.:

**DTM distribution valve 3/2 pull rod operated, spring return G1/8, wired, no. 24.0105.3218 1 pc.**

# DTM SERIES

Distribution valves for pent mounting,  
manually operated by means of a pull rod - wired



## VALVE DTM 3/2 (FOR PENT)

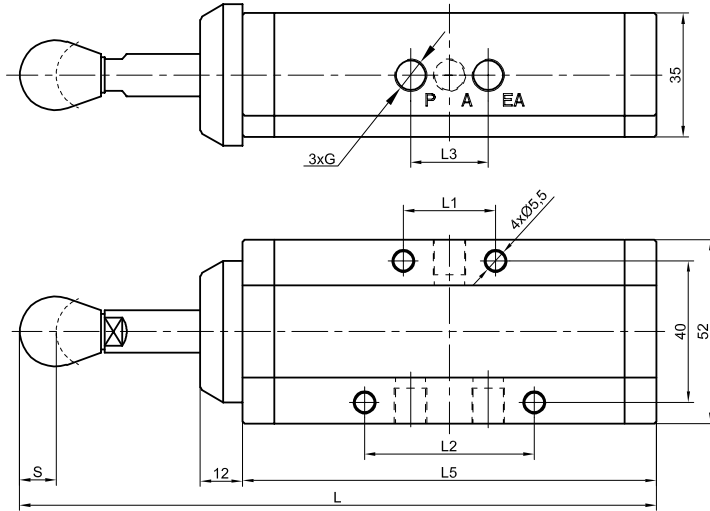
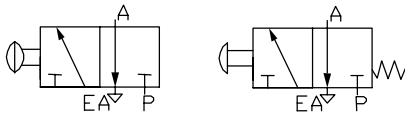

G	L	L1	L2	L3	L5	S
G1/8	180	26	48	22	117	10
G1/4	200	34	66	32	132	15

## VALVE DTM 5/2 (FOR PENT)

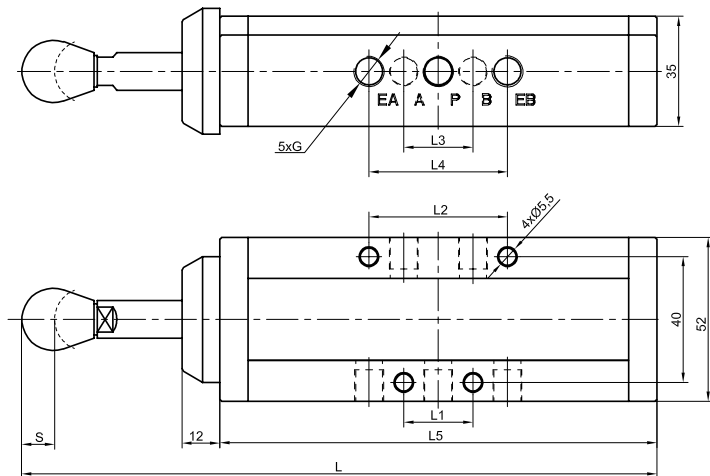
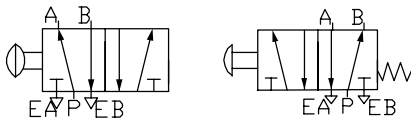

G	L	L1	L2	L3	L4	L5	S
G1/8	202	22	44	22	44	139	10
G1/4	232	32	62	32	64	164	15

## TECHNICAL SPECIFICATIONS

<b>Operating pressure range:</b>	0 — 10 bar
<b>Operating temperature range:</b>	0 to + 65°C
<b>Medium:</b>	compressed air, filtered, lubricated
<b>Construction materials:</b>	<p><b>Body</b> - aluminium alloy</p> <p><b>Covers</b> - ZnAl alloy</p> <p><b>Slider</b> - aluminium alloy</p> <p><b>Seals</b> - polyurethane PU</p>



Number of paths / valve positions	Graphical symbol	Control type and operating pressure range	Connection thread	Nominal diameter	Order number	
					Valve	Subplate
3/2		pull rod 0 — 10 bar	G1/4	Ø 7.5	24.0102.3214	25.0101.323314
			G3/8	Ø 12	24.0102.3238	25.0101.323338
			G1/2	Ø 16	24.0102.3212	25.0101.323312
			G3/4	Ø 20	24.0102.3234	25.0101.323334
		pull rod, spring return 0 — 10 bar	G1/4	Ø 7.5	24.0104.3214	25.0101.323314
			G3/8	Ø 12	24.0104.3238	25.0101.323338
			G1/2	Ø 16	24.0104.3212	25.0101.323312
			G3/4	Ø 20	24.0104.3234	25.0101.323334
		lever 0 — 10 bar	G1/4	Ø 7.5	24.0108.3214	25.0101.323314
			G3/8	Ø 12	24.0108.3238	25.0101.323338
			G1/2	Ø 16	24.0108.3212	25.0101.323312
			G3/4	Ø 20	24.0108.3234	25.0101.323334
	lever, spring return 0 — 10 bar	G1/4	Ø 7.5	24.0110.3214	25.0101.323314	
		G3/8	Ø 12	24.0110.3238	25.0101.323338	
		G1/2	Ø 16	24.0110.3212	25.0101.323312	
		G3/4	Ø 20	24.0110.3234	25.0101.323334	
	rollers 0 — 10 bar	G1/4	Ø 7.5	24.0122.3214	25.0101.323314	
		G3/8	Ø 12	24.0122.3238	25.0101.323338	
	roller, spring return 0 — 10 bar	G1/4	Ø 7.5	24.0124.3214	25.0101.323314	
		G3/8	Ø 12	24.0124.3238	25.0101.323338	
3/3		lever, locking with a latch, in the middle position all paths cut off 0 — 10 bar	G1/4	Ø 7.5	24.0112.3314	25.0101.323314
			G3/8	Ø 12	24.0112.3338	25.0101.323338
			G1/2	Ø 16	24.0112.3312	25.0101.323312
			G3/4	Ø 20	24.0112.3334	25.0101.323334
		lever, locking with springs, in the middle position all paths cut off 0 — 10 bar	G1/4	Ø 7.5	24.0118.3314	25.0101.323314
			G3/8	Ø 12	24.0118.3338	25.0101.323338
			G1/2	Ø 16	24.0118.3312	25.0101.323312
			G3/4	Ø 20	24.0118.3334	25.0101.323334



# DTM SERIES

Distribution valves for plate mounting,  
manually operated by means of a pull rod, lever, roller



5/2		pull rod 0 — 10 bar	G1/8	Ø 7.5	24.0102.521814	25.0102.525318		
			G1/4			25.0102.525314		
			G1/4			Ø 12	24.0102.521438	25.0103.525314
			G3/8					25.0103.525338
			G1/2					25.0104.525312
			G3/4			Ø 20	24.0102.521234	25.0104.525334
	G1/8	25.0102.525318						
		pull rod, spring return 0 — 10 bar	G1/8	Ø 7.5	24.0104.521814	25.0102.525318		
			G1/4			25.0102.525314		
			G1/4			Ø 12	24.0104.521438	25.0103.525314
			G3/8					25.0103.525338
			G1/2					25.0104.525312
G3/4			Ø 20			24.0104.521234	25.0104.525334	
G1/8	25.0102.525318							
	lever 0 — 10 bar	G1/4	Ø 7.5	24.0108.521814	25.0102.525318			
		G1/4			25.0102.525314			
		G1/4			Ø 12	24.0108.521438	25.0103.525314	
		G3/8					25.0103.525338	
		G1/2					25.0104.525312	
		G3/4			Ø 20	24.0108.521234	25.0104.525334	
G1/8	25.0102.525318							
	lever, spring return 0 — 10 bar	G1/4	Ø 7.5	24.0110.521814	25.0102.525318			
		G1/4			25.0102.525314			
		G1/4			Ø 12	24.0110.521438	25.0103.525314	
		G3/8					25.0103.525338	
		G1/2					25.0104.525312	
		G3/4			Ø 20	24.0110.521234	25.0104.525334	
G1/8	25.0102.525318							
	rollers 0 — 10 bar	G1/4	Ø 7.5	24.0122.521814	25.0102.525318			
		G1/4			25.0102.525314			
		G1/4			Ø 12	24.0122.521438	25.0103.525314	
		G3/8					25.0103.525338	
		G1/2					25.0104.525312	
		G3/4			Ø 20	24.0122.521234	25.0104.525334	
G1/8	25.0102.525318							
5/3		lever, locking with a latch, in the middle position all paths vented 0 — 10 bar	G1/8	Ø 7.5	24.0114.531814	25.0102.525318		
			G1/4			25.0102.525314		
			G1/4			Ø 12	24.0114.531438	25.0103.525314
			G3/8					25.0103.525338
			G1/2					25.0104.525312
			G3/4			Ø 20	24.0114.531234	25.0104.525334
	G1/8	25.0102.525318						
		lever, locking with a latch, in the middle position all paths cut off 0 — 10 bar	G1/4	Ø 7.5	24.0116.531814	25.0102.525318		
			G1/4			25.0102.525314		
			G1/4			Ø 12	24.0116.531438	25.0103.525314
			G3/8					25.0103.525338
			G1/2					25.0104.525312
G3/4			Ø 20			24.0116.531234	25.0104.525334	
G1/8	25.0102.525318							
	lever, locking with springs, in the middle position all paths vented 0 — 10 bar	G1/4	Ø 7.5	24.0120.531814	25.0102.525318			
		G1/4			25.0102.525314			
		G1/4			Ø 12	24.0120.531438	25.0103.525314	
		G3/8					25.0103.525338	
		G1/2					25.0104.525312	
		G3/4			Ø 20	24.0120.531234	25.0104.525334	
G1/8	25.0102.525318							
	lever, locking with springs, in the middle position all paths cut off 0 — 10 bar	G1/4	Ø 7.5	24.0118.531814	25.0102.525318			
		G1/4			25.0102.525314			
		G1/4			Ø 12	24.0118.531438	25.0103.525314	
		G3/8					25.0103.525338	
		G1/2					25.0104.525312	
		G3/4			Ø 20	24.0118.531234	25.0104.525334	

## ORDERING PROCEDURE

In your order, please specify the name of the valve, number of paths/positions, connection thread, order number and the number of pieces, e.g.:

Distribution valve 3/2 pull rod operated, spring return G3/8, for plate mounting, no. 24.0104.3238 1 pc.

## VALVE DTM 3/2

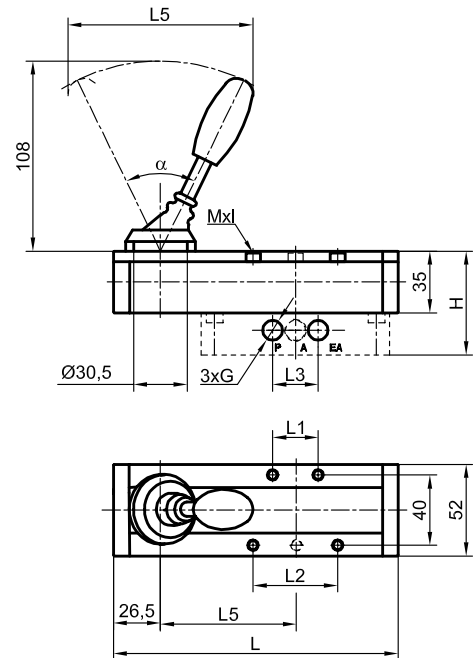
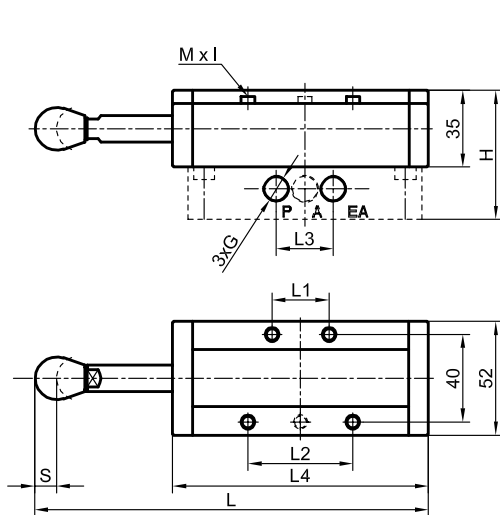
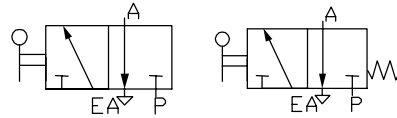
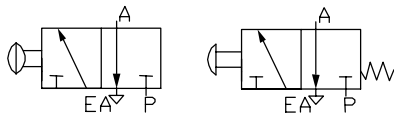

G	H	L	L1	L2	L3	L4	S	M x l
G1/4	59	180	26	48	26	117	10	M5x40-4pcs
G3/8	64	200	34	66	35	132	15	M5x40-4pcs
G1/2	69	220	39	81	48	147	20	M5x40-4pcs
G3/4	74	250	52	92	52	172	25	M5x40-5pcs

G	H	L	L1	L2	L3	L4	L5	alpha	M x l
G1/4	59	162	26	48	26	72	77	26	M5x40-4pcs
G3/8	64	177	34	66	35	96	85	36	M5x40-4pcs
G1/2	69	192	39	81	48	112	92	48	M5x40-4pcs
G3/4	74	217	52	92	52	126	105	56	M5x40-5pcs

## VALVE DTM 3/2

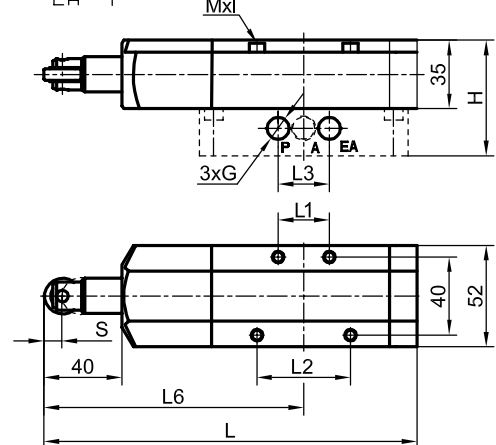
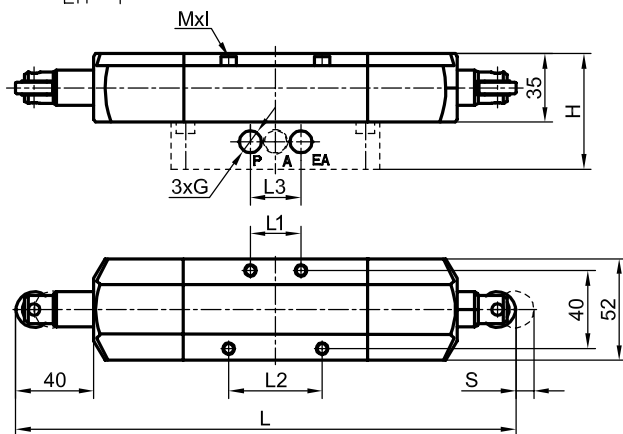
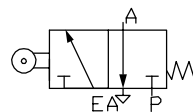
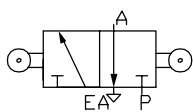

G	H	L	L1	L2	L3	S	M x l
G1/4	59	256	26	48	26	10	M5x40-4pcs
G3/8	64	266	34	66	35	15	M5x40-4pcs

G	H	L	L1	L2	L3	L6	S	M x l
G1/4	59	191	26	48	26	133	10	M5x40-4 pcs
G3/8	64	206	34	66	35	140	15	M5x40-4 pcs

# DTM SERIES

Distribution valves for plate mounting,  
manually operated by means of a pull rod, lever, roller



## VALVE DTM 3/3

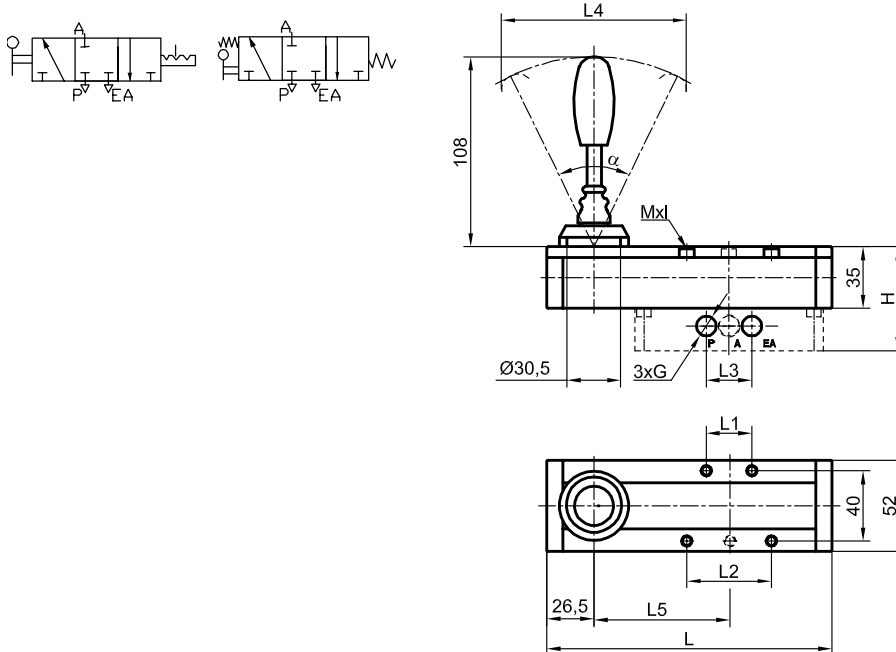

G	H	L	L1	L2	L3	L4	L5	α	Mxl
G1/4	59	162	26	48	26	72	77	26	M5x40-4pcs
G3/8	64	177	34	66	35	96	85	36	M5x40-4pcs
G1/2	69	192	39	81	48	112	92	48	M5x40-4pcs
G3/4	74	217	52	92	52	126	105	56	M5x40-5pcs

## DISTRIBUTION VALVE 5/2

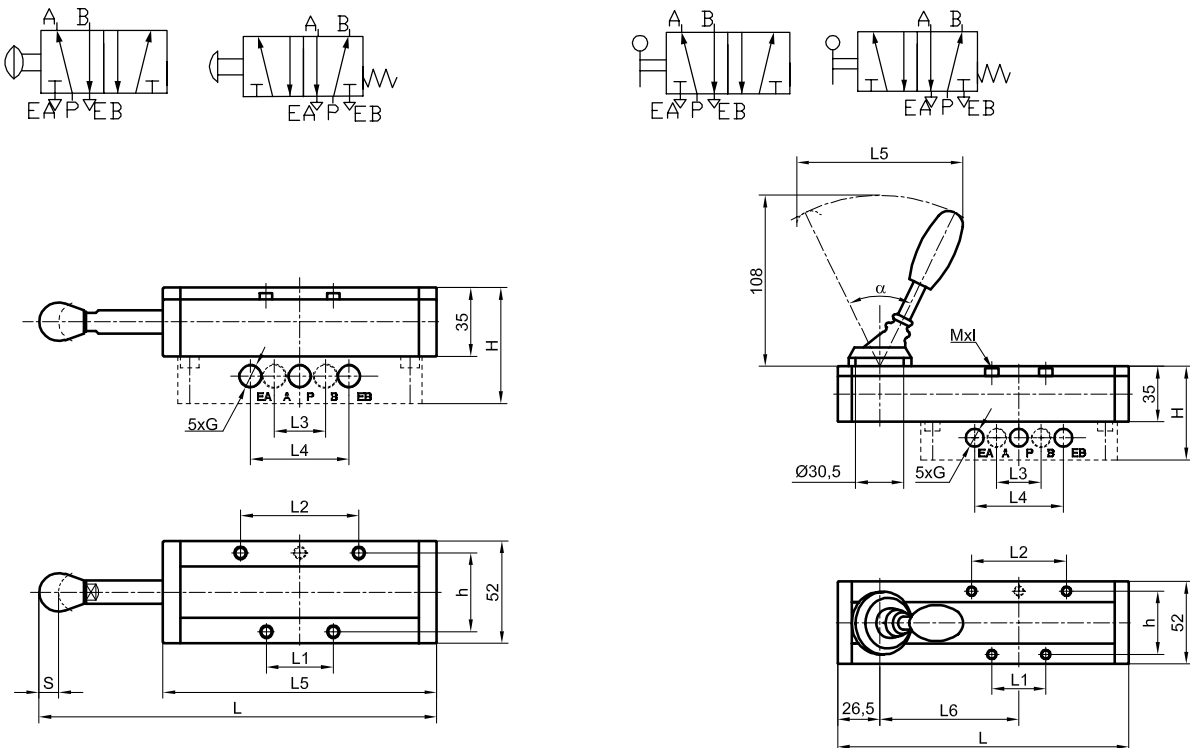

G	H	L	L1	L2	L3	L4	L5	S	h	Mxl
G1/8-G1/4	59	202	34	60	26	56	139	10	40	M5x40-4pcs
G1/4-G3/8	65	232	48	86	35	70	164	15	42	M5x40-4pcs
G1/2-G3/4	73	282	52	104	52	104	224	25	40	M6x40-5pcs

G	H	L	L1	L2	L3	L4	L5	L6	α	h	Mxl
G1/8-G1/4	59	184	34	60	26	56	72	88	26	40	M5x40-4pcs
G1/4-G3/8	65	209	48	86	35	70	96	100	36	42	M5x40-4pcs
G1/2-G3/4	73	269	52	104	52	104	126	131	56	40	M6x40-5pcs

## VALVE DTM 5/2

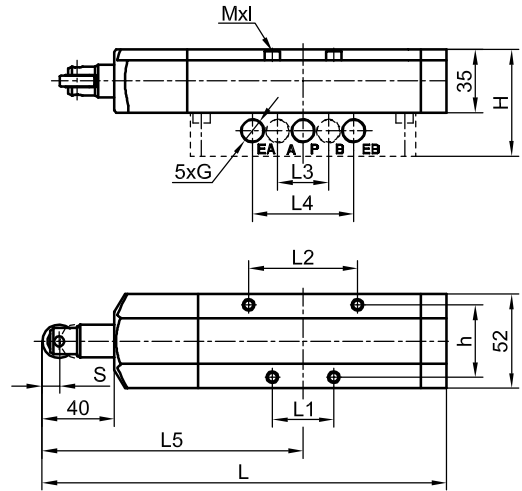
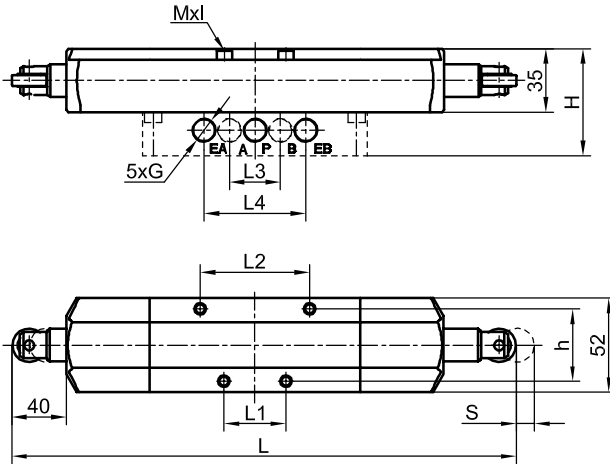
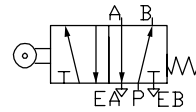
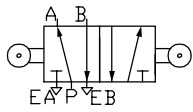

G	H	L	L1	L2	L3	L4	S	h	Mxl
G1/8-G1/4	59	278	34	60	26	56	10	40	M5x40-4 pcs
G1/4-G3/8	65	298	48	86	35	70	15	42	M5x40-4 pcs

G	H	L	L1	L2	L3	L4	L5	S	h	Mxl
G1/8-G1/4	59	213	34	60	26	56	144	10	40	M5x40-4 pcs
G1/4-G3/8	65	238	48	86	35	70	156	15	42	M5x40-4 pcs

## VALVE DTM 5/3

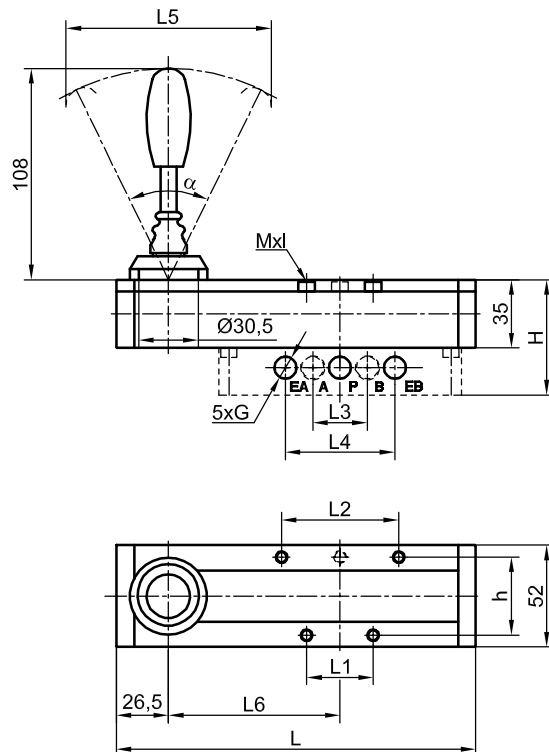
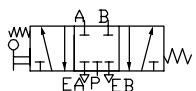
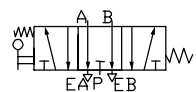
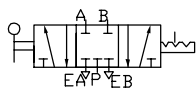
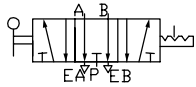

G	H	L	L1	L2	L3	L4	L5	L6	$\alpha$	h	Mxl
G1/8-G1/4	59	184	34	60	26	56	72	88	26	40	M5x40-4pcs
G1/4-G3/8	65	209	48	86	35	70	96	100	35	42	M5x40-4pcs
G1/2-G3/4	73	269	52	104	52	104	126	131	56	40	M6x40-5pcs



### TECHNICAL SPECIFICATIONS

<b>Operating pressure range:</b>	0 — 10 bar
<b>Operating temperature range:</b>	0 to + 90°C
<b>Medium:</b>	compressed air, filtered, lubricated
<b>Construction materials:</b>	
<b>Body</b>	- aluminium
<b>Distribution plate</b>	- brass



Number of paths / valve positions	Graphical symbol	Control type and operating pressure range	Connection thread	Order number
4/3		lever, in the middle position all paths cut off 0 — 10 bar	G1/8	<b>24.0407.4318</b>
			G3/8	<b>24.0407.4338</b>
			G1/2	<b>24.0407.4312</b>
		lever, in the middle position all paths vented 0 — 10 bar	G1/8	<b>24.0401.4318</b>
			G3/8	<b>24.0401.4338</b>
			G1/2	<b>24.0401.4312</b>
		lever, in the middle position all paths connected with the supply 0 — 10 bar	G1/8	<b>24.0404.4318</b>
			G3/8	<b>24.0404.4338</b>
			G1/2	<b>24.0404.4312</b>
		lever with pneumatic lock, middle position - cut off 0 — 10 bar	G3/8	<b>24.0408.4338</b>
		lever with pneumatic lock, middle position - vented 0 — 10 bar		<b>24.0402.4338</b>
		lever with pneumatic lock, middle position - connected to supply 0 — 10 bar		<b>24.0405.4338</b>

### ORDERING PROCEDURE

In your order, please specify the name of the valve, number of paths/positions, connection thread, order number and the number of pieces, e.g.:

**Distribution valve 4/3 G3/8 lever-operated, no. 24.0401.4338 1 pc.**

# PM SERIES

## Distribution valves lever-operated - plate



### VALVE PM 4/3 G1/8

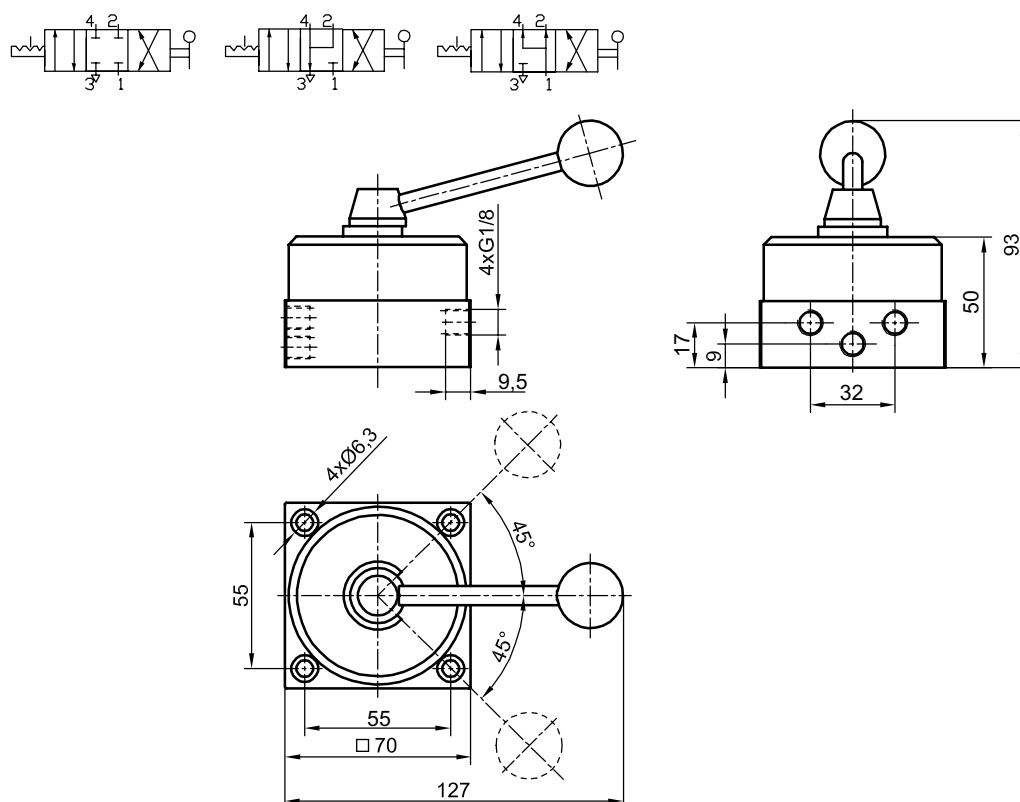

### VALVE PM 4/3 G3/8

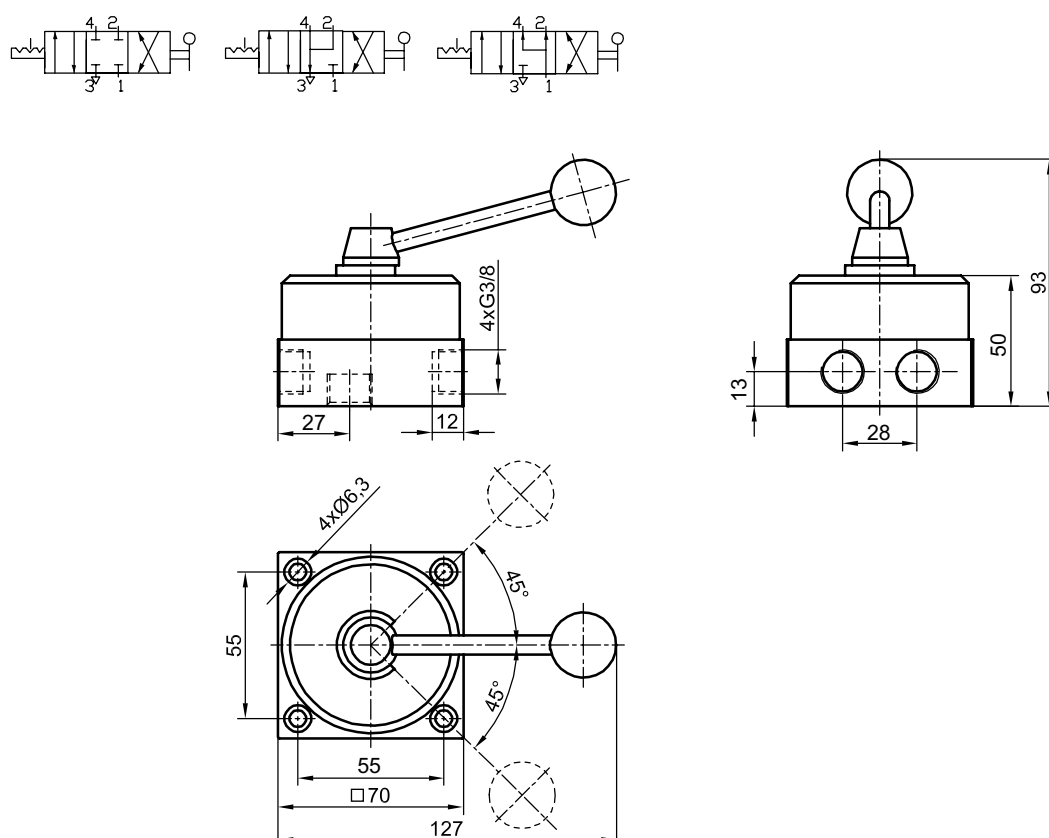

## VALVE PM 4/3 G3/8

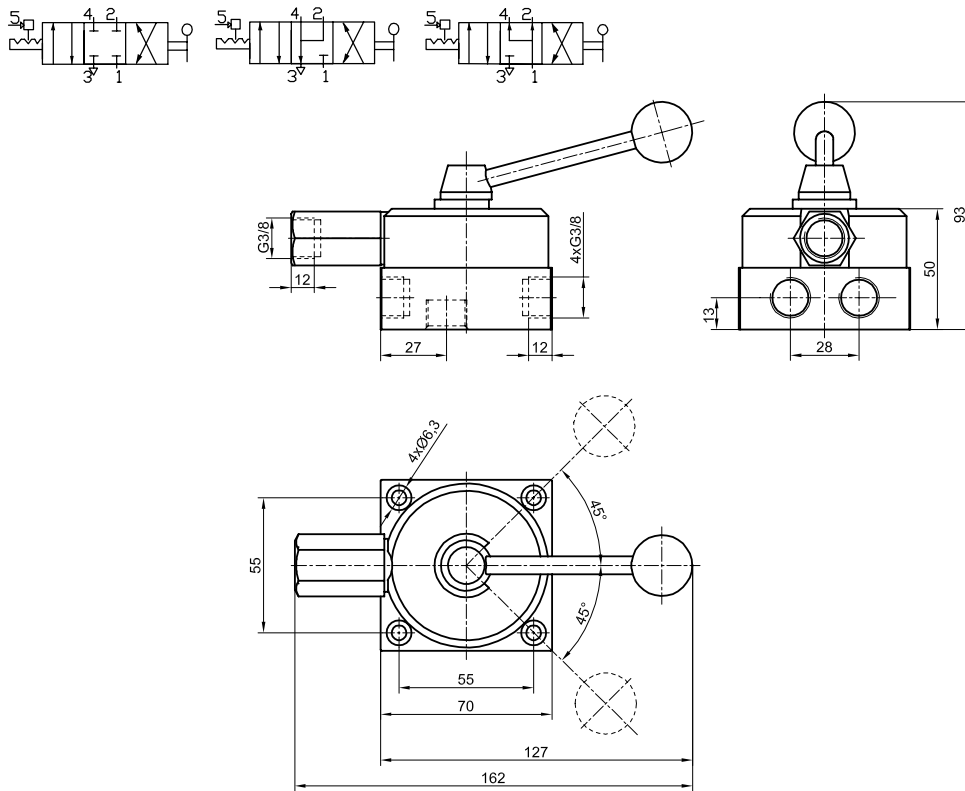

## VALVE PM 4/3 G1/2

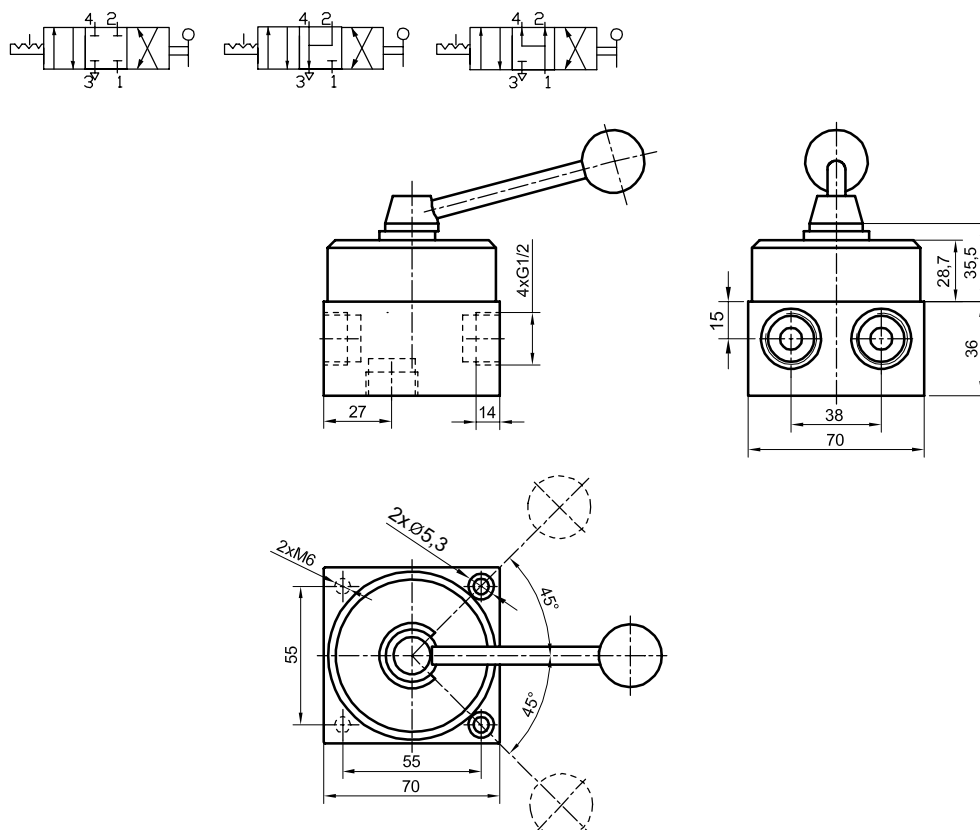





## TECHNICAL SPECIFICATIONS

<b>Operating pressure range:</b>	0 — 10 bar
<b>Operating temperature range:</b>	0 to + 65°C
<b>Medium:</b>	wired or plate-based, compressed air, filtered, lubricated or non-lubricated
<b>Construction materials:</b>	<p><b>Body</b> - aluminium</p> <p><b>Slider</b> - stainless steel</p> <p><b>Seals</b> - polyurethane PU</p>



## SUPPORT DISTRIBUTION VALVE G1/8 - HEAD MOUNTING METHOD

### VALVE PZR 3/2

### VALVE PZR 5/2

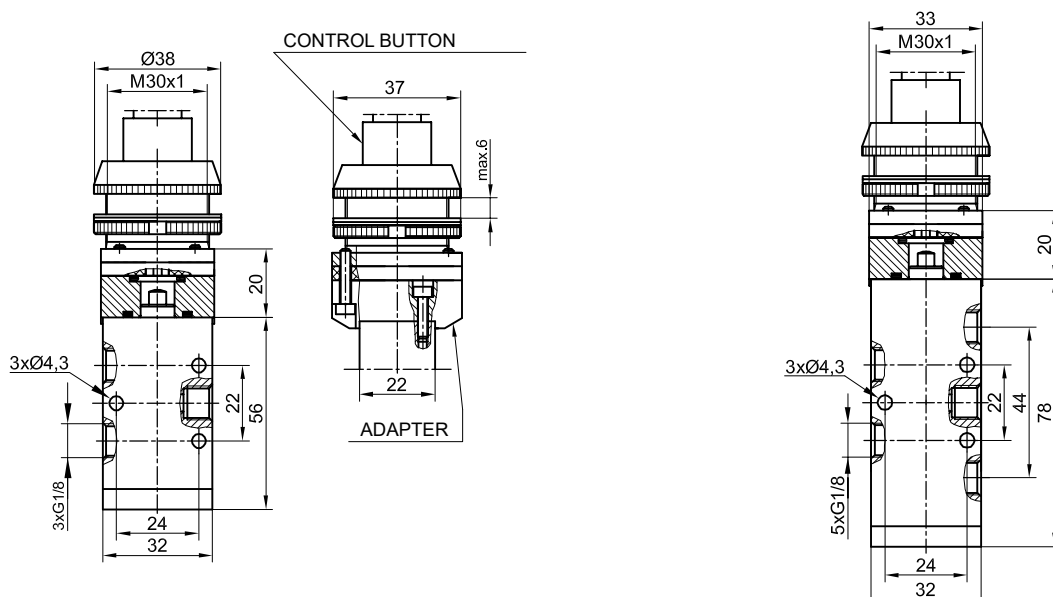

# PZR SERIES

Support distribution valves  
mechanically operated



## SUPPORT DISTRIBUTION VALVE G1/8 - BASIC VALVE, PUSH ROD OPERATED

### VALVE PZR 3/2

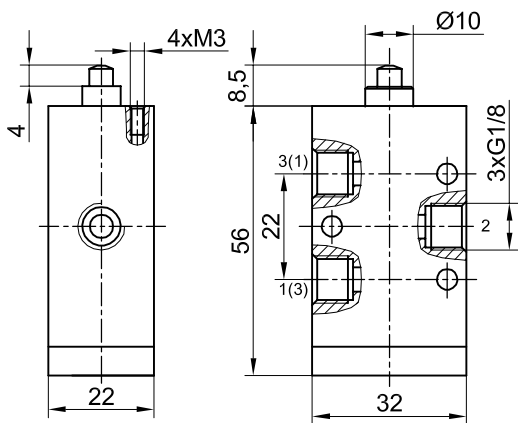

Number of paths / valve positions	Order number
3/2	24.2600.3218

### VALVE PZR 5/2

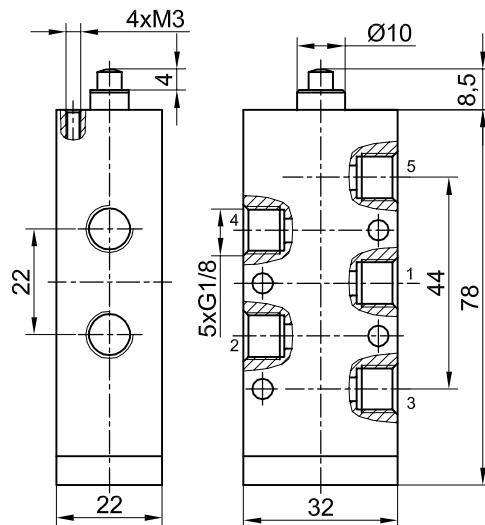

Number of paths / valve positions	Order number
5/2	24.2600.5218

## SUPPORT DISTRIBUTION VALVE 2/2, 3/2 G1/8

### - operated by a covered button

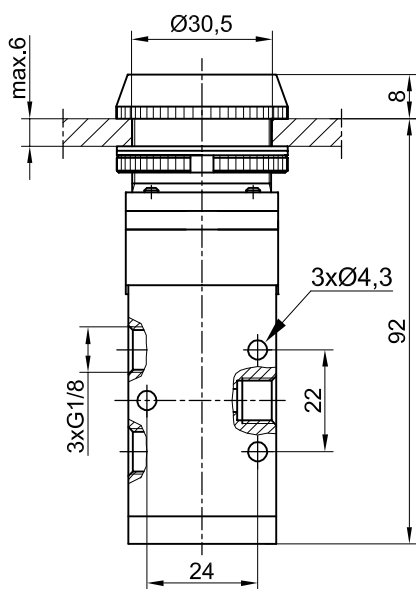
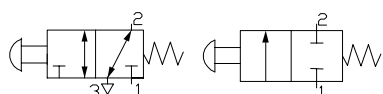

Number of paths / valve positions	Order number	
	Red button	Green button
2/2 NC (NO)	24.2603.2218	24.2604.2218
3/2 NC (NO)	24.2603.3218	24.2604.3218

### - operated by a protruding button

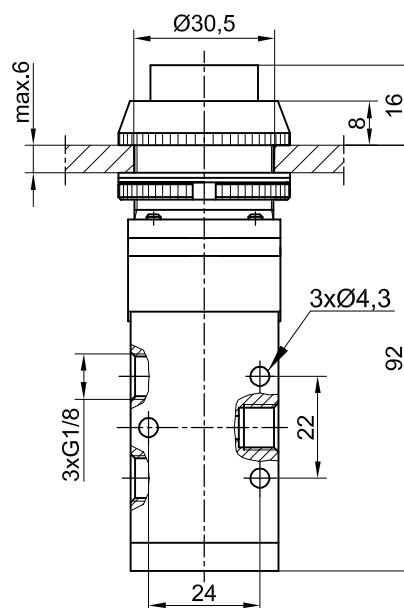
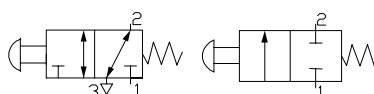

Number of paths / valve positions	Order number	
	Red button	Green button
2/2 NC (NO)	24.2622.2218	24.2606.2218
3/2 NC (NO)	24.2622.3218	24.2606.3218

### SUPPORT DISTRIBUTION VALVE 2/2, 3/2 G1/8

- operated by a hand button

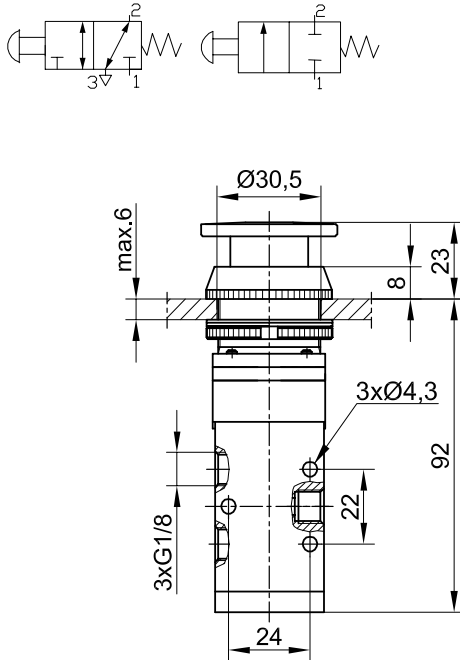

Number of paths / valve positions	Order number	
	Red button	Green button
2/2 NC (NO)	24.2623.2218	24.2602.2218
3/2 NC (NO)	24.2623.3218	24.2602.3218

- operated by a lockable hand button

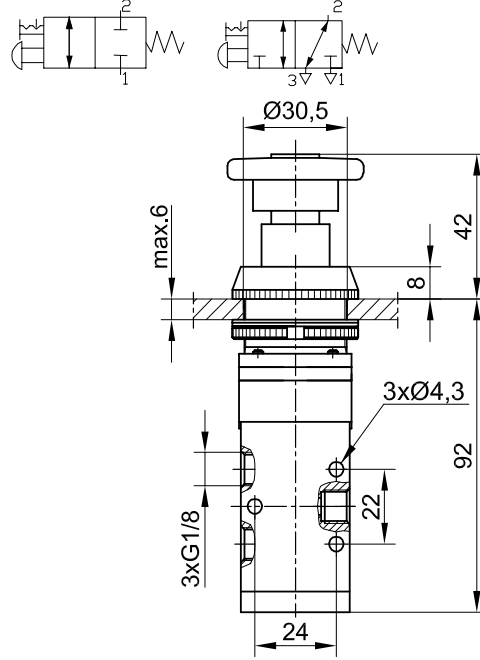

Number of paths / valve positions	Order number
	Red button
2/2 NC (NO)	24.2619.2218
3/2 NC (NO)	24.2619.3218

### SUPPORT DISTRIBUTION VALVE 2/2, 3/2 G1/8

- operated by a rotary switch

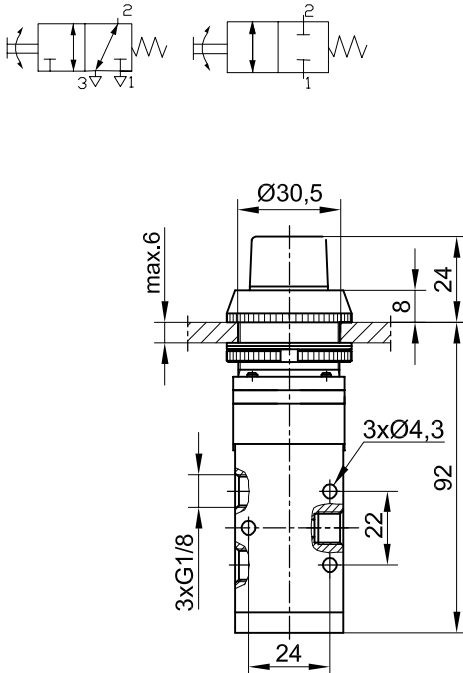

Number of paths / valve positions	Order number
	2/2 NC (NO)
3/2 NC (NO)	24.2605.3218

- key operated

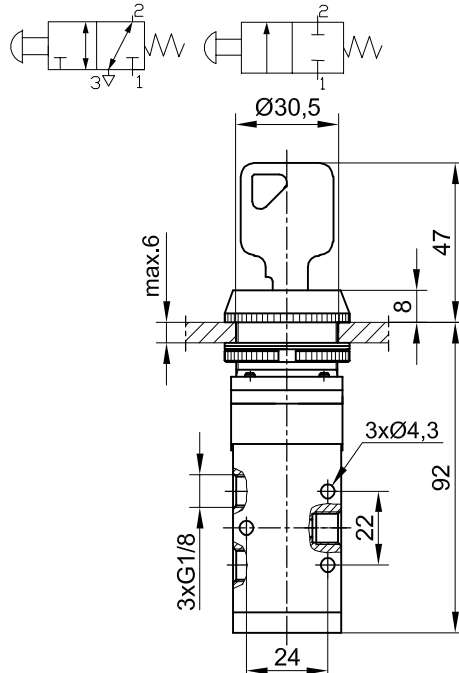

Number of paths / valve positions	Order number
	2/2 NC (NO)
3/2 NC (NO)	24.2608.3218

Note: The key can only be removed/inserted in its initial position

### SUPPORT DISTRIBUTION VALVE 5/2 G1/8

- operated by a covered button

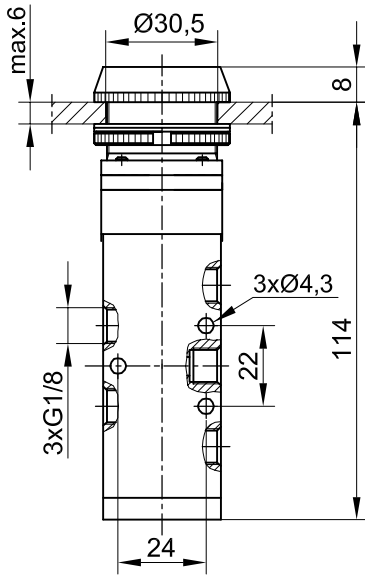
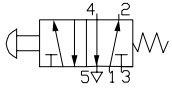

Number of paths / valve positions	Order number	
	Red button	Green button
5/2	24.2603.5218	24.2604.5218

- operated by a protruding button

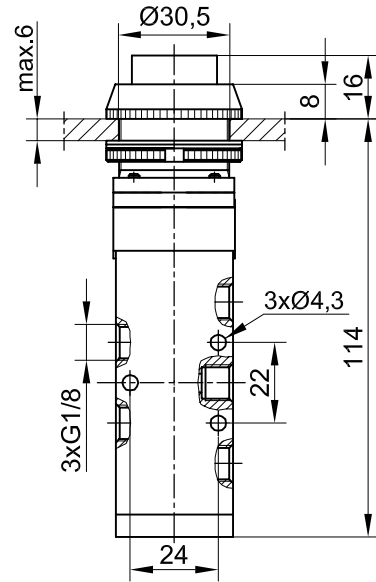
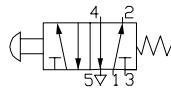

Number of paths / valve positions	Order number	
	Red button	Green button
5/2	24.2622.5218	24.2606.5218

### SUPPORT DISTRIBUTION VALVE 5/2 G1/8

- operated by a hand button

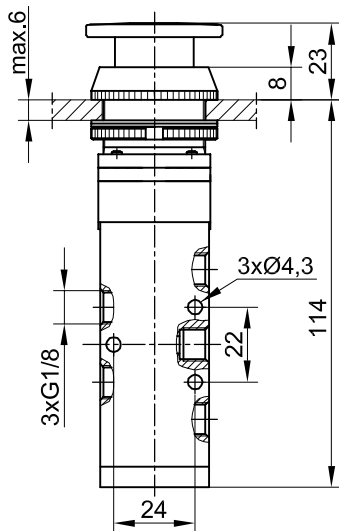
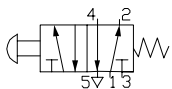

Number of paths / valve positions	Order number	
	Red button	Green button
5/2	24.2623.5218	24.2602.5218

- operated by a lockable hand button

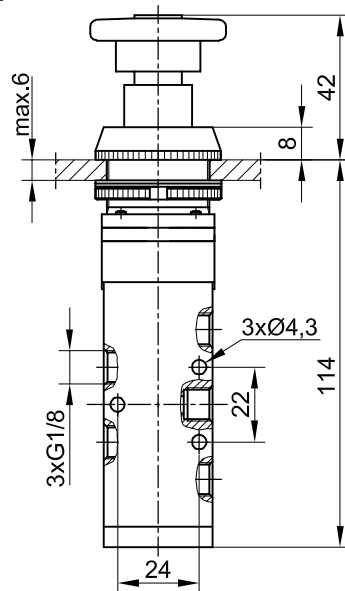
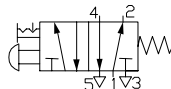

Number of paths / valve positions	Order number	
	Red button	
5/2	24.2619.5218	

### SUPPORT DISTRIBUTION VALVE 5/2 G1/8

- operated by a rotary switch

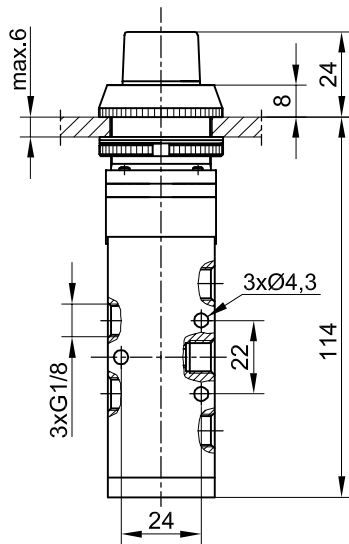
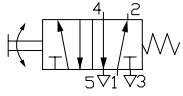

Number of paths / valve positions	Order number
5/2	24.2605.5218

- key operated

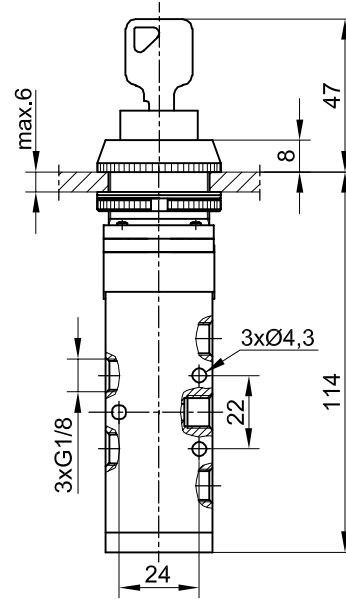
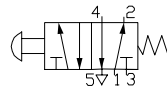

Number of paths / valve positions	Order number
5/2	24.2608.5218

Note: The key can only be removed/inserted in its initial position

### SUPPORT DISTRIBUTION VALVE 3/2 NO, NC G1/8

- double-acting operation – lever with roller

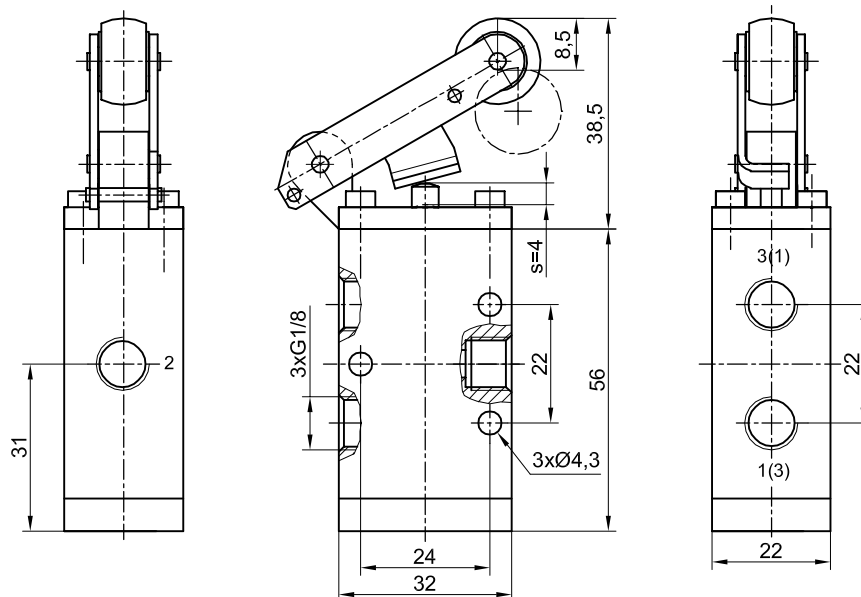
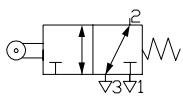

Number of paths / valve positions	Order number
3/2	24.2616.3218

# PZR SERIES

Mechanically operated support distribution valves



## SUPPORT DISTRIBUTION VALVE 5/2 G1/8

- double-acting operation – lever with roller

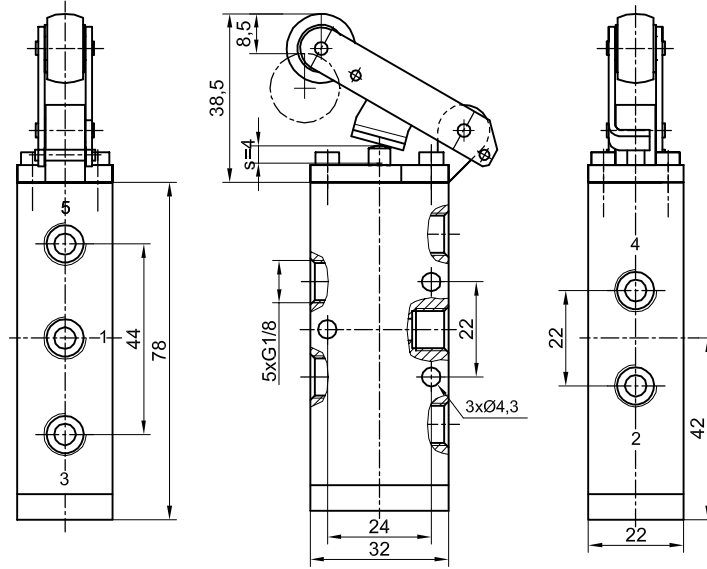
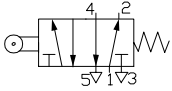

Number of paths / valve positions	Order number
5/2	24.2616.5218

### ORDERING PROCEDURE

In your order, please specify: name, number of paths / positions, connection thread, order number and number of pieces, e.g.:

**Support distribution valve PZR 3/2 G1/8 mechanically operated by a covered button no. 24.2603.2218 1 pc.**

## TECHNICAL SPECIFICATIONS

<b>Operating pressure range:</b>	1.5 — 10 bar
<b>Operating temperature range:</b>	0 to + 65°C
<b>Medium:</b>	compressed air, filtered, lubricated
<b>Construction materials:</b>	<p><b>Body</b> - aluminium alloy</p> <p><b>Slider</b> - aluminium alloy</p> <p><b>Seals</b> - nitrile-butadiene rubber (NBR)</p>



## VALVE PZR FOR HOSE Ø4, BOTTOM CONNECTION

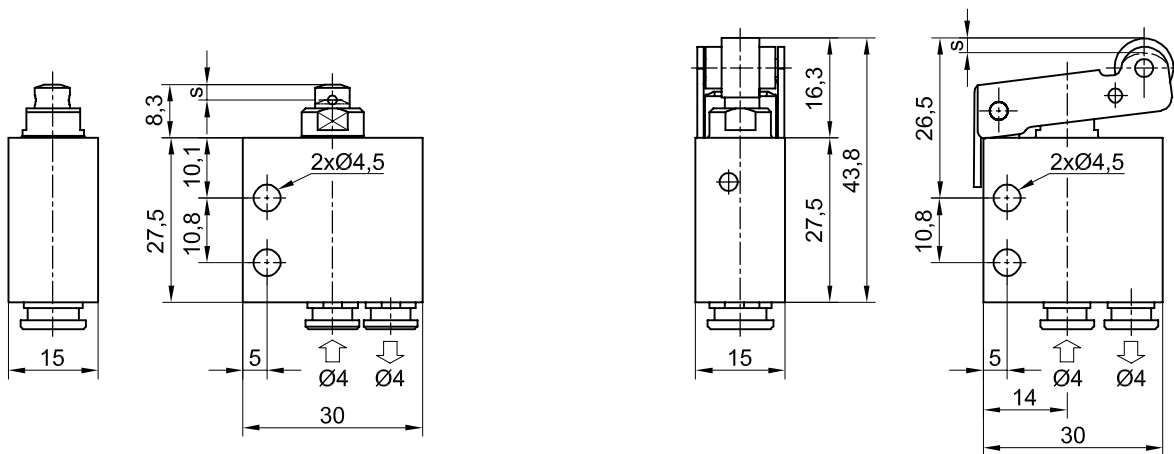

Number of paths / valve positions	Graphical symbol	Operating pressure range	s	Order number
2/2 NC		1.5– 10 bar	1.75	24.1601.204MA
3/2 NC			1.75	24.1601.304MA
3/2 NO			2	24.1601.314MA

Number of paths / valve positions	Graphical symbol	Operating pressure range	s	Order number
2/2 NC		1.5 — 10 bar	3	24.1603.204MR
3/2 NC			4	24.1603.304MR
3/2 NO			5	24.1603.314MR



# PZR MINI SERIES

Support distribution valves  
mechanically operated



## VALVE PZR FOR HOSE Ø4, BOTTOM CONNECTION

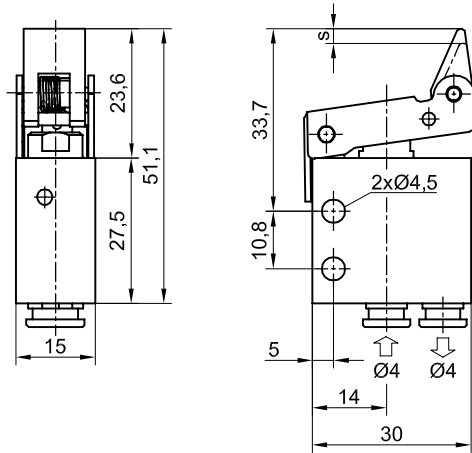

Number of paths / valve positions	Graphical symbol	Operating pressure range	s	Order number
2/2 NC		1.5 — 10 bar	4	24.1605.204MS
3/2 NC			4	24.1605.304MS
3/2 NO			6	24.1605.314MS

## VALVE PZR FOR HOSE Ø4, SIDE CONNECTION

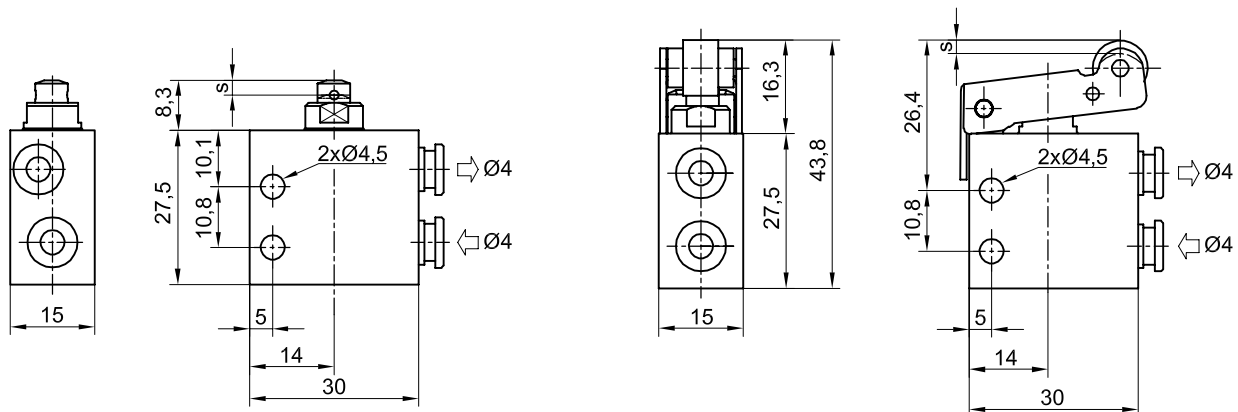

Number of paths / valve positions	Graphical symbol	Operating pressure range	s	Order number	Number of paths / valve positions	Graphical symbol	Operating pressure range	s	Order number
2/2 NC		1.5 — 10 bar	1.75	24.1601.204MAUL	2/2 NC		15 — 10 bar	3	24.1603.204MRUL
3/2 NC			1.75	24.1601.304MAUL	3/2 NC			4	24.1603.304MRUL
3/2 NO			2	24.1601.314MAUL	3/2 NO			5	24.1603.314MRUL

## VALVE PZR FOR HOSE Ø4, SIDE CONNECTION

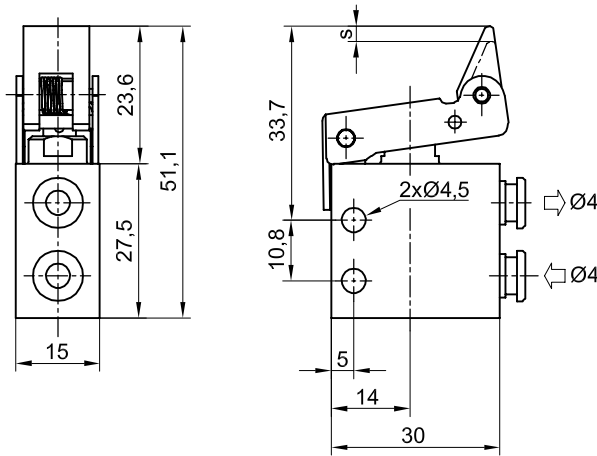

Number of paths / valve positions	Graphical symbol	Operating pressure range	s	Order number
2/2 NC		1.5 — 10 bar	4	24.1605.204MSUL
3/2 NC			4	24.1605.304MSUL
3/2 NO			5	24.1605.314MSUL

## VALVE PZR WITH M5 THREAD, SIDE CONNECTION

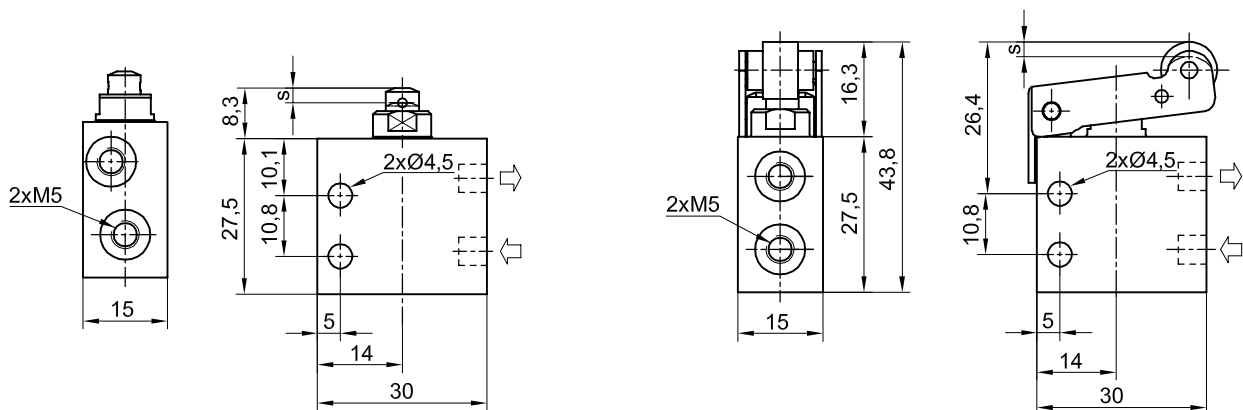

Number of paths / valve positions	Graphical symbol	Operating pressure range	s	Order number	Number of paths / valve positions	Graphical symbol	Operating pressure range	s	Order number
2/2 NC		1.5 — 10 bar	1.75	24.1601.205MAUL	2/2 NC		1.5 — 10 bar	3	24.1603.205MRUL
3/2 NC			1.75	24.1601.305MAUL	3/2 NC			4	24.1603.305MRUL
3/2 NO			2	24.1601.315MAUL	3/2 NO			5	24.1603.315MRUL

# PZR MINI SERIES

Support distribution valves  
mechanically operated



## VALVE PZR WITH M5 THREAD, SIDE CONNECTION

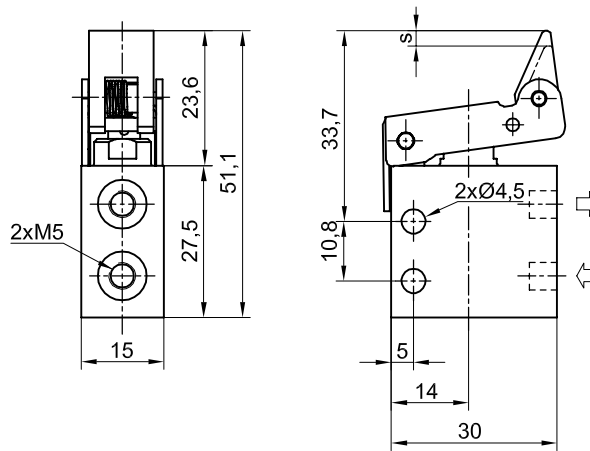

Number of paths / valve positions	Graphical symbol	Operating pressure range	s	Order number
2/2 NC		1.5 — 10 bar	4	24.1605.205MSUL
3/2 NC			4	24.1605.305MSUL
3/2 NO			6	24.1605.315MSUL

## VALVE PZR WITH M5 THREAD, BOTTOM CONNECTION

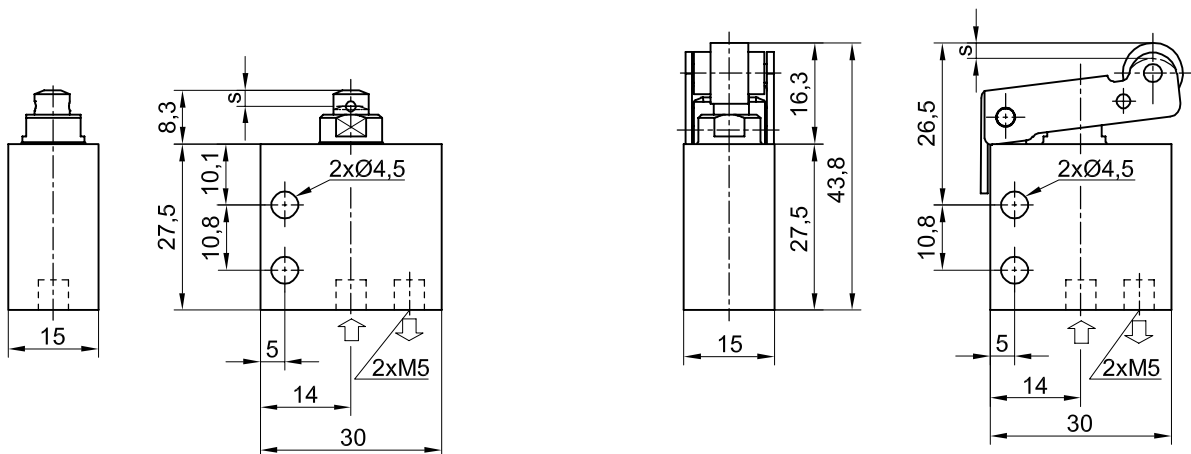

Valve function	Graphical symbol	Operating pressure range	s	Order number	Valve function	Graphical symbol	Operating pressure range	s	Order number
2/2 NC		1.5 — 10 bar	1.75	24.1601.205MA	2/2 NC		1.5 — 10 bar	3	24.1603.205MR
3/2 NC			1.75	24.1601.305MA	3/2 NC			4	24.1603.305MR
3/2 NO			2	24.1601.315MA	3/2 NO			5	24.1603.315MR

## VALVE PZR WITH M5 THREAD, BOTTOM CONNECTION

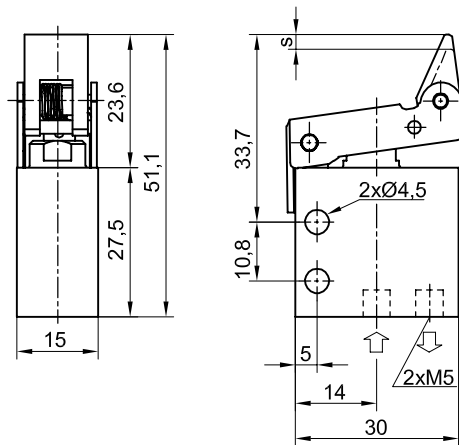

Number of paths / valve positions	Graphical symbol	Operating pressure range	s	Order number
2/2 NC		1.5 — 10 bar	4	24.1605.205MS
3/2 NC			4	24.1605.305MS
3/2 NO			6	24.1605.315MS

## VALVE PZR WITH M5 THREAD TO HEAD, BOTTOM CONNECTION

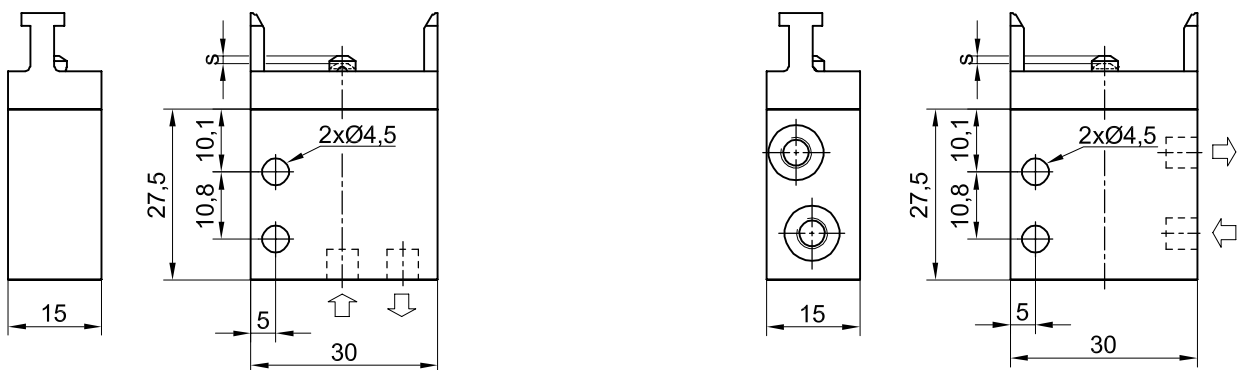

Number of paths / valve positions	Graphical symbol	Operating pressure range	s	Order number	Number of paths / valve positions	Graphical symbol	Operating pressure range	s	Order number
2/2 NC		1.5 — 10 bar	1.75	24.1611.205MB	2/2 NC		1.5 — 10 bar	1.75	24.1611.205MBUL
3/2 NC			1.75	24.1611.305MB	3/2 NC			1.75	24.1611.305MBUL
3/2 NO			2	24.1611.315MB	3/2 NO			2	24.1611.315MBUL

# PZR MINI SERIES

## Support distribution valves mechanically operated



### HEADS FOR VALVES SERIES 24.1611

#### - with a covered button

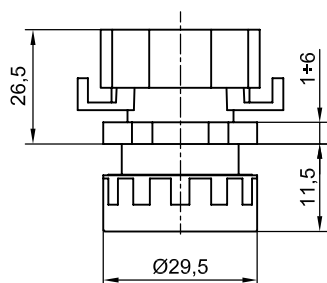

Button colour	Order number
RED	24.1611.01RED
GREEN	24.1611.01GREEN

#### - with a mushroom button

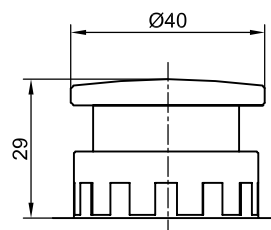

Button colour	Order number
RED	24.1611.02RED
BLACK	24.1611.02BLACK

#### - with rotary knob

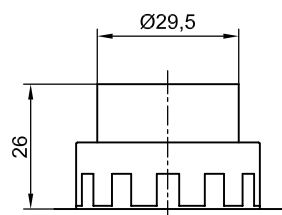

Button colour	Order number
BLACK	24.1611.03BLACK

### ORDERING PROCEDURE

In your order, please specify: name, number of paths / positions, connection thread, order number and number of pieces, e.g.:

**Support distribution valve PZR 3/2 G1/8 mechanically operated by a covered button no. 24.2603.2218 1 pc.**

### TECHNICAL SPECIFICATIONS

<b>Operating pressure range:</b>	2.0 — 10 bar
<b>Operating temperature range:</b>	0 to + 60°C
<b>Medium:</b>	compressed air, filtered, lubricated
<b>Construction materials:</b>	
<b>Base, foot, housing, cover</b>	- plastic
<b>Distribution valve</b>	- aluminium alloy
<b>Seals</b>	- nitrile-butadiene rubber (NBR)

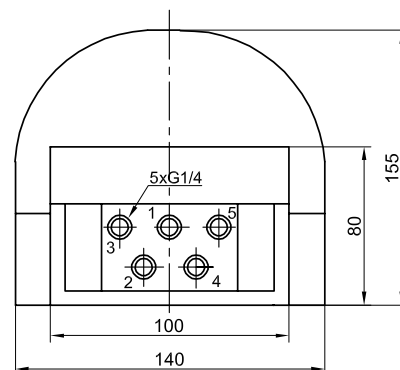
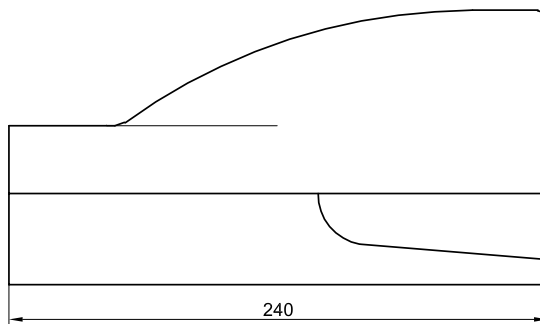

Valve name	Order number
Distribution valve 5/2 G1/4 foot-operated with locking	<b>24.0414.5214</b>
Distribution valve 5/2 G1/4 foot-operated, spring return	<b>24.0413.5214</b>

### ORDERING PROCEDURE

In your order, please specify: name, connection thread, order number and the number of pieces, e.g.:

**Distribution valve 5/2 G1/4 foot-operated, spring return, no. 24.0413.5214 1 pc.**



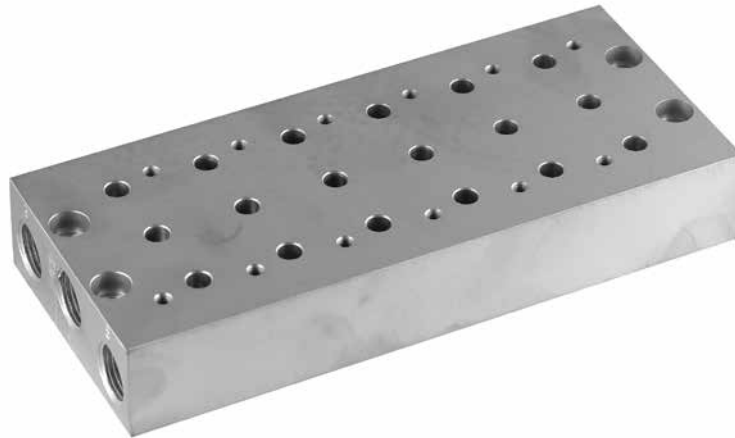

## ORDER NUMBERS

Number of paths in the plate-mounted distribution valves	Valve connection thread	Subplate connection thread marked: 1, 3, 5	Order number of blanking plugs	Order number of the subplate
3-way	G1/8	G1/4	29.2630.3218	<b>26.0701.3218nn</b>
	G1/4	G3/8	29.2630.3214	<b>26.0701.3214nn</b>
5-way	G1/8	G3/8	29.2630.5218	<b>26.0701.5218nn</b>
	G1/4		29.2630.5214	<b>26.0701.5214nn</b>

## ORDERING PROCEDURE

In your order, please specify: name, order number of the subplate (nn- number of valves mounted on the plate), number and type of distribution valves used (order numbers of ZMG valves can be found on pages 245, 283), e.g.:

- 1) Subplate for ZMG 5/2 G1/8 valves n=06 no. 26.1701.521806 1 pc.
- 2) Distribution valve ZMG 5/2 G1/8 electromagnetically operated, spring return 24V no. 22.0703.5218B 3 pcs.
- 3) Distribution valve ZMG 5/2 G1/8 electromagnetically operated, 24V no. 22.0701.5214B 3 pcs.



# SUBPLATE

for distribution valves series ZMG, ZMG P



## SUBPLATE FOR 3/2 G1/8 ZMG VALVES

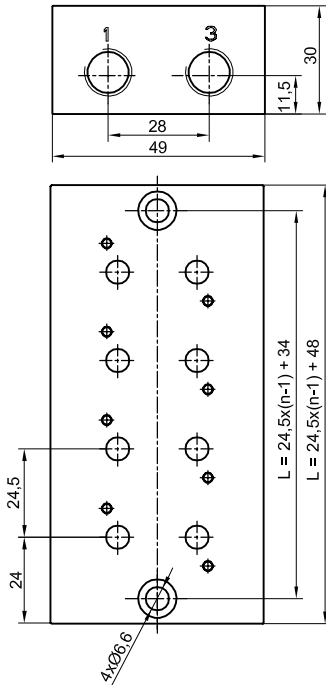

## SUBPLATE FOR 3/2 G1/4 ZMG VALVES

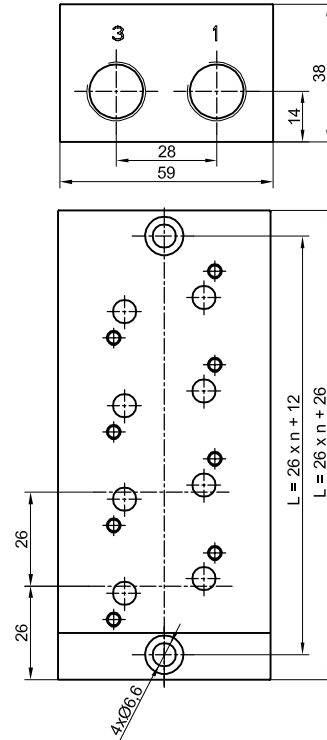

## SUBPLATE FOR 5/2 G1/8 ZMG VALVES

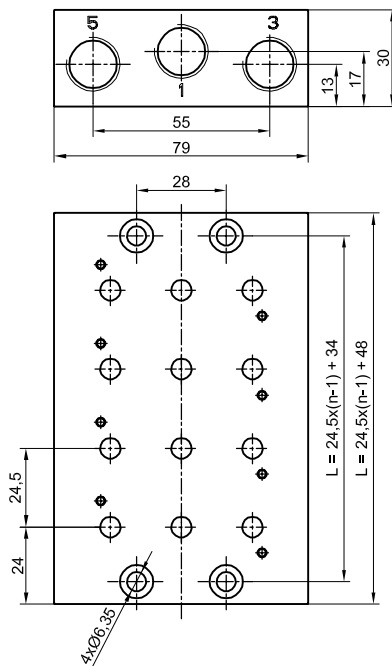

## SUBPLATE FOR 5/2 G1/4 ZMG VALVES

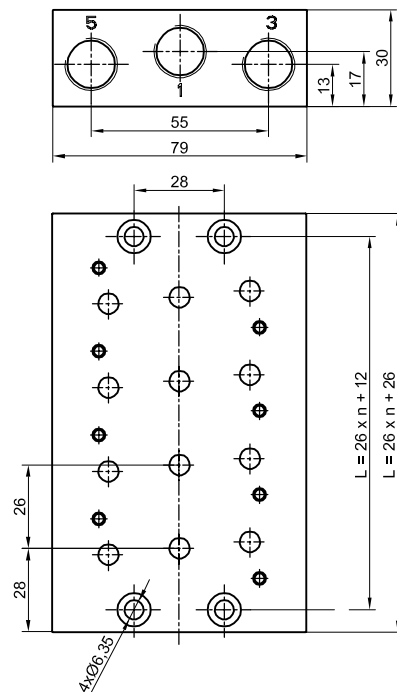



### VALVE FUNCTION: 5/2, 5/3

### VALVE FUNCTION: 3/2

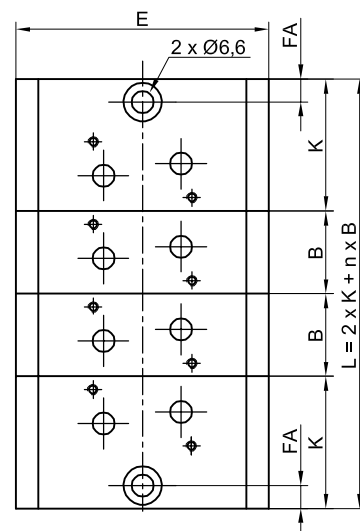
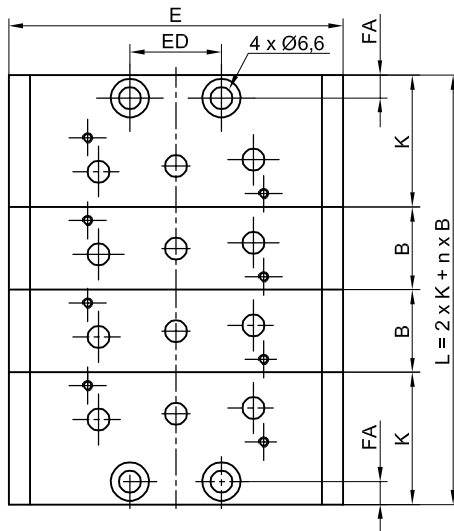
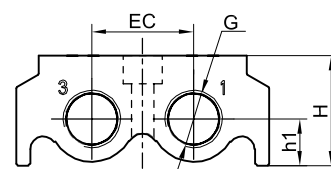
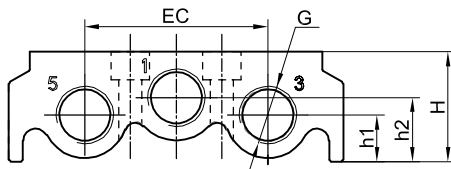

Number of paths / valve positions	Valve connection thread	B	E	EC	ED	FA	G	H	h1	h2	K	Order number of the blinding plug	Order number of the subplate
3/2	G1/8	23.5	72	29	-	6.5	G3/8	31.5	13.5	-	37.5	29.2630.3218	26.2701.3218xx
3/2	G1/4	27	72	29	-	6.5	G3/8	31.5	13.5	-	41	29.2630.3214	26.2701.3214xx
5/2, 5/3	G1/8	23.5	95	52	26	6.5	G3/8	31.5	13.5	18.5	37.5	29.2630.5218	26.2701.5218xx
5/2, 5/3	G1/4	27	95	52	26	6.5	G3/8	31.5	13.5	18.5	41	29.2630.5214	26.2701.5214xx

### ORDERING PROCEDURE

In your order, please specify the name and function of the valve, connection thread, order number, (nn - number of valves installed in the terminal) and the number of pieces, e.g.:

**Segmented subplate ZMG 5/2 G1/4 nn=06 no. 26.2701.521406 1 pc.**





## ORDER NUMBERS

Number of paths in the plate-mounted distribution valves	Valve connection thread	Subplate connection thread marked: 1, 3, 5	Order number of blanking plugs	Order number of the subplate
3-way	G1/4	G3/8	29.2635.3214	26.1701.3214nn
5-way	G1/4	G3/8	29.2635.5214	26.1701.5214nn

## ORDERING PROCEDURE

In your order, please specify: name, order number of the subplate (nn- number of valves installed in the terminal), number and type of distribution valves used (order numbers of ZEM valves can be found on page 251) and the number of pieces e.g.:

- 1) Subplate for ZEM 5/2 G1/4 valves n=06 no. 26.1701.521406 1 pc.
- 2) Distribution valve ZEM 5/2 G1/4 electromagnetically operated, spring return 24V no. 22.1703.5214B 3 pcs.
- 3) Distribution valve ZEM 5/2 G1/4 electromagnetically operated, 24V no. 22.1701.5214B 3 pcs.

## VALVE TERMINAL FOR ZEM 3/2 G1/4 VALVES

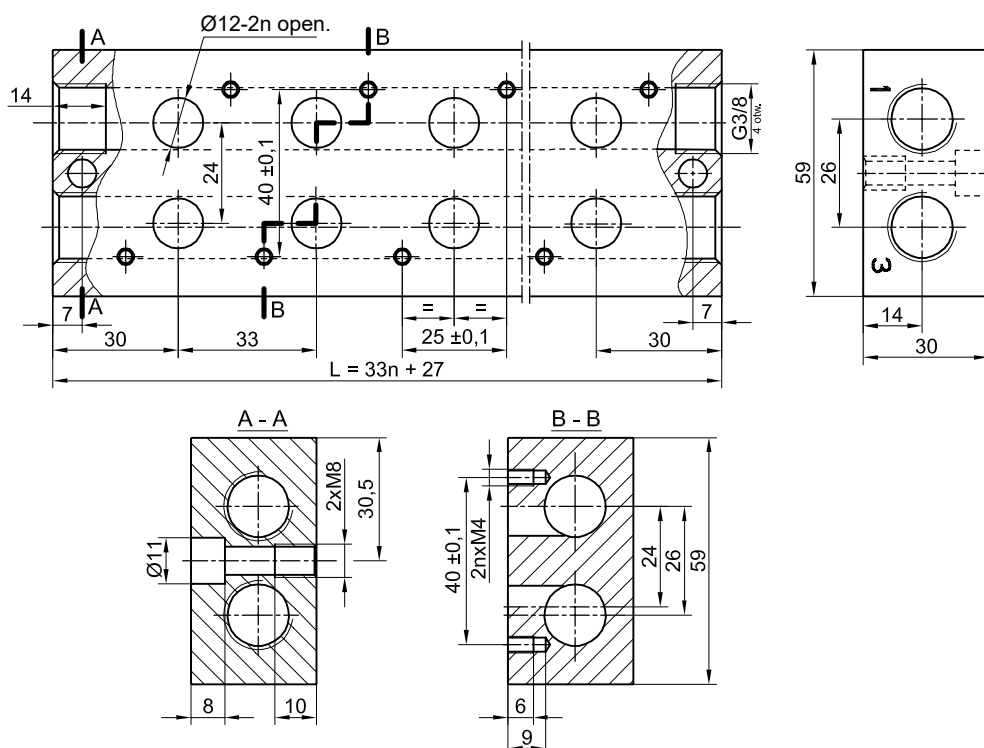

# SUBPLATE

for distribution valves series ZEM G1/4



## VALVE TERMINAL FOR ZEM 5/2 G1/4 VALVES

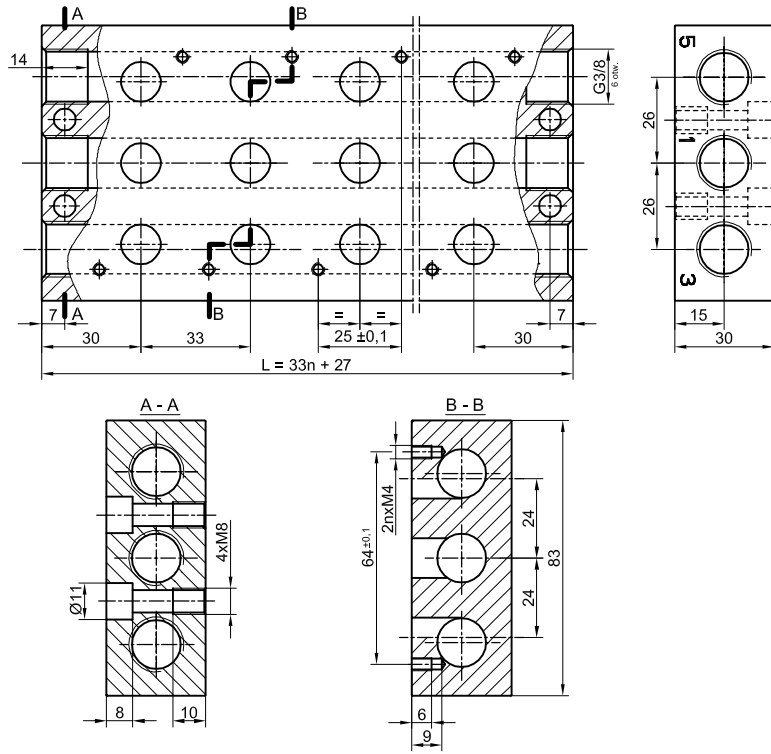



## VALVE FUNCTION: 5/2, 5/3

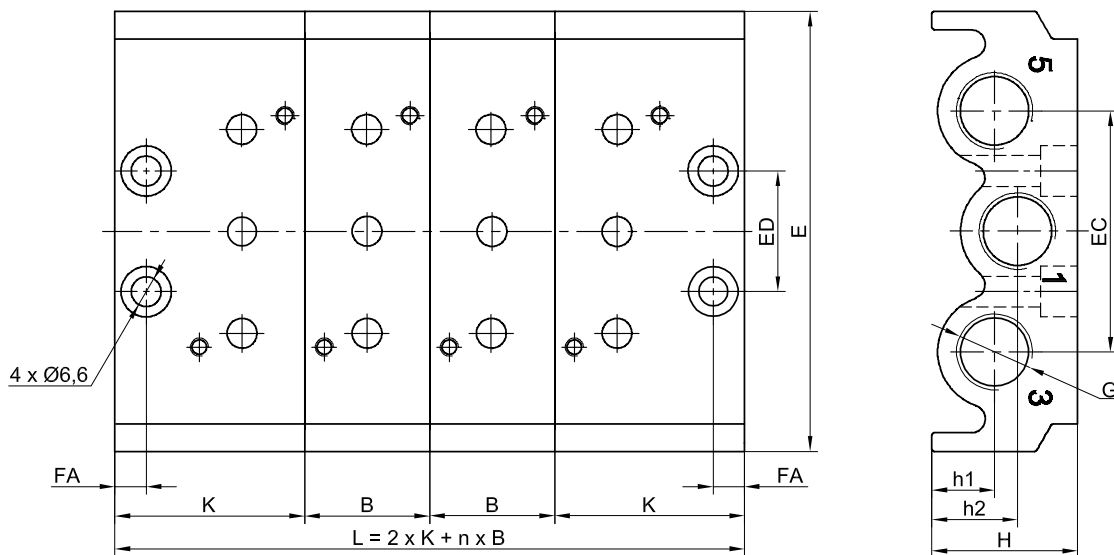

## VALVE FUNCTION: 3/2, 3/3

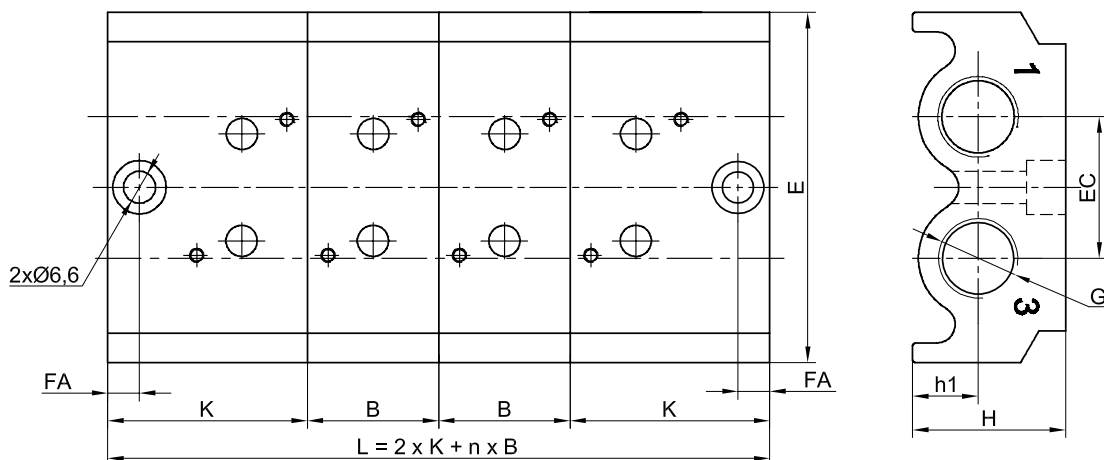

Valve function	Valve connection thread	B	E	EC	ED	FA	G	H	h1	h2	K	Order number of the blinding plug	Order number of the block
5/2, 5/3	G1/4	34	95	52	26	6.5	G3/8	31.5	13.5	18.5	48	29.2635.5214	26.2711.5214xx
3/2, 3/3	G1/4	34	72	29	-	6.5	G3/8	31.5	13.5	-	48	29.2635.3214	26.2711.3214xx

## ORDERING PROCEDURE

In your order, please specify the name and function of the valve, connection thread, order number, (nn - number of valves mounted on the plate) and the number of pieces (order numbers for ZEM valves can be found on page 251), e.g.:

Segmented subplate ZEM 5/2 G1/4 nn=08 no. 26.2711.521408 1 pc.



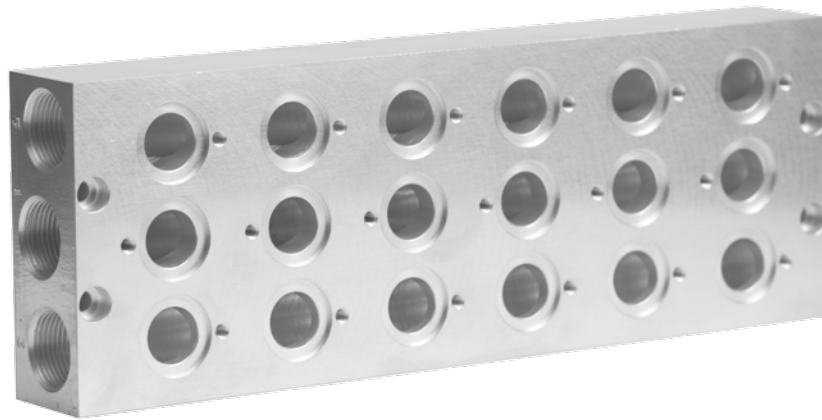

## ORDER NUMBERS

Number of paths in the plate-mounted distribution valves	Valve connection thread	Subplate connection thread marked: 1, 3, 5	Order number of blanking plugs	Order number of the subplate
3-way	G1/2	G3/4	29.2634.3212	26.1901.3212nn
5-way	G1/2	G3/4	29.2634.5212	26.1901.5212nn

## ORDERING PROCEDURE

In your order, please specify: name, order number of the subplate (nn- number of valves mounted on the plate), number and type of distribution valves used (order numbers of ZDE valves can be found on pages 265, 266), e.g.:

- 1) Subplate for ZDE 5/2 G1/2 valves n=05 no. 26.1901.521205 1 pc.
- 2) Distribution valve ZDE 5/2 G1/2 electromagnetically operated, spring return 24V no. 22.1903.5212B 3 pcs.
- 3) Distribution valve ZDE 5/2 G1/2 electromagnetically operated 24V no. 22.1901.5212B 2 pcs.

## VALVE TERMINAL FOR ZDE 3/2 G1/2 VALVES

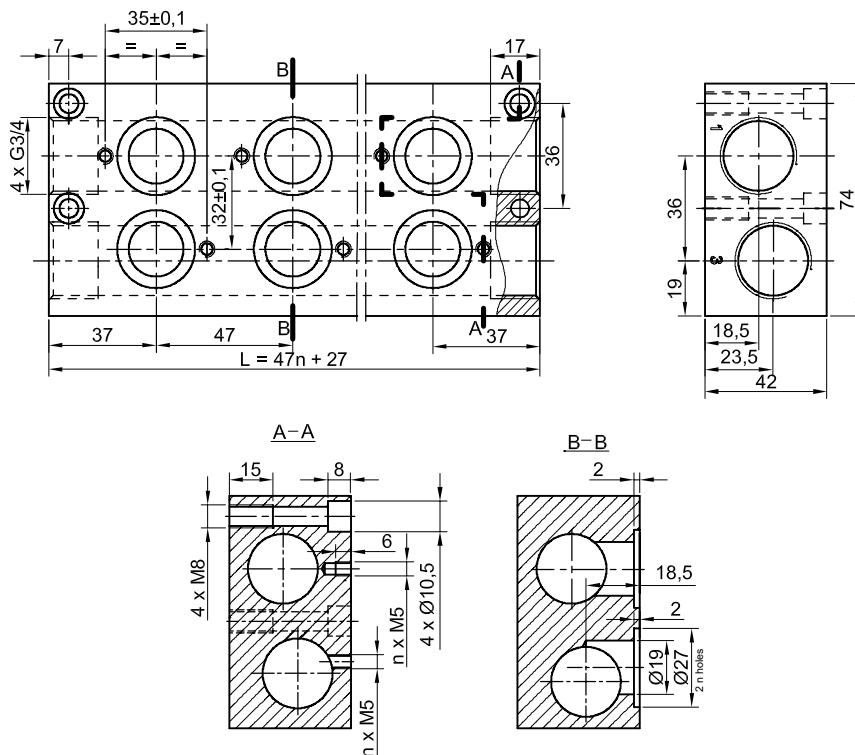



# SUBPLATE

for distribution valves series ZDE



## VALVE TERMINAL FOR ZDE 5/2 G1/2 VALVES

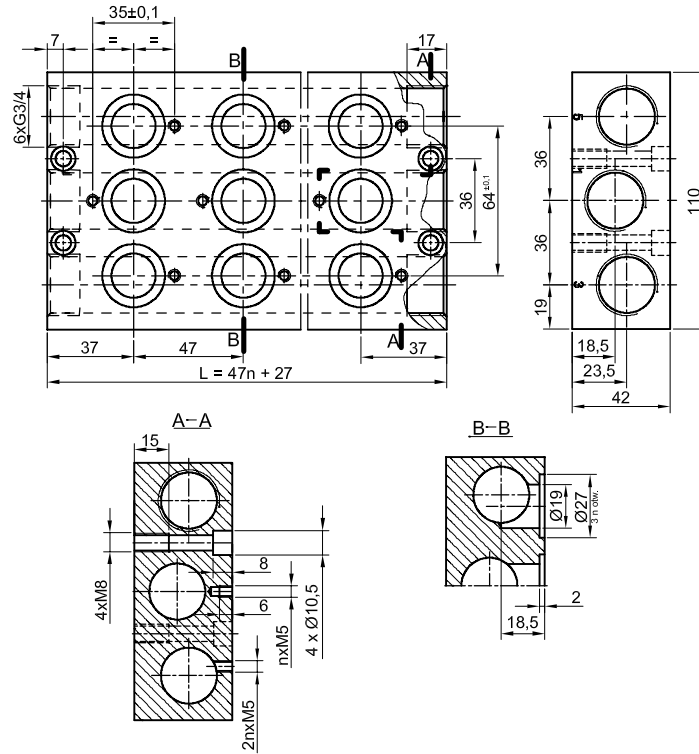

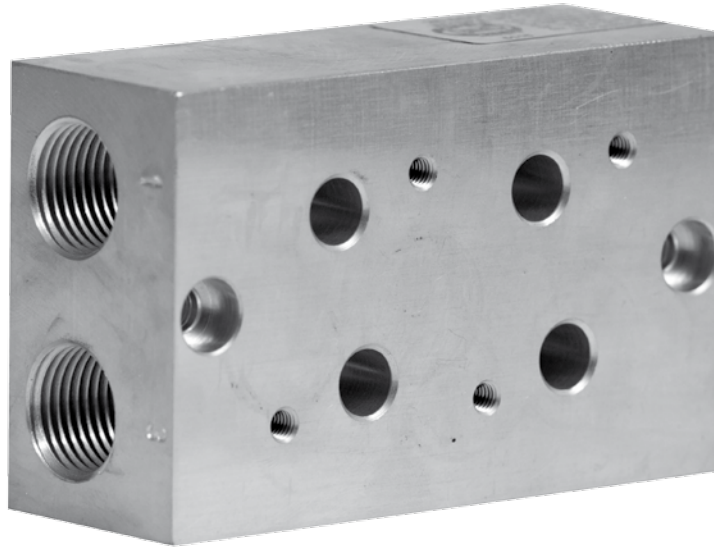

## ORDER NUMBERS

Number of paths in the plate-mounted distribution valves	Valve connection thread	Subplate connection thread marked: 1, 3, 5	Order number of blanking plugs	Order number of the subplate
3-way	G3/8	G1/2	29.2632.3238	26.0801.3238nn
5-way			29.2632.5238	26.0801.5238nn

## ORDERING PROCEDURE

In your order, please specify: name, order number of the subplate (nn- number of valves installed in the terminal), number and type of distribution valves used (order numbers of ZE valves can be found on pages 259, 260) and number of pieces e.g.:

- 1) Subplate for ZE 5/2 G3/8 valves n=06 no. 26.0801.523806 1 pc.
- 2) Distribution valve ZE 5/2 G3/8 electromagnetically operated, spring return 24V no. 22.0803.5238B 3 pcs.
- 3) Distribution valve ZE 5/2 G3/8 electromagnetically operated, 24V no. 22.0801.5238B 3 pcs.

## SUBPLATE FOR ZE 3/2 G3/8 VALVES

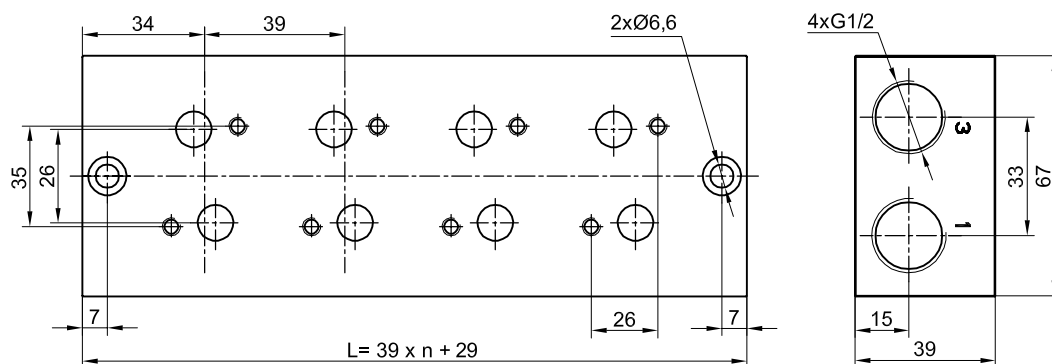

# SUBPLATE

for distribution valves series ZE



## SUBPLATE FOR ZE 5/2 G3/8 VALVES

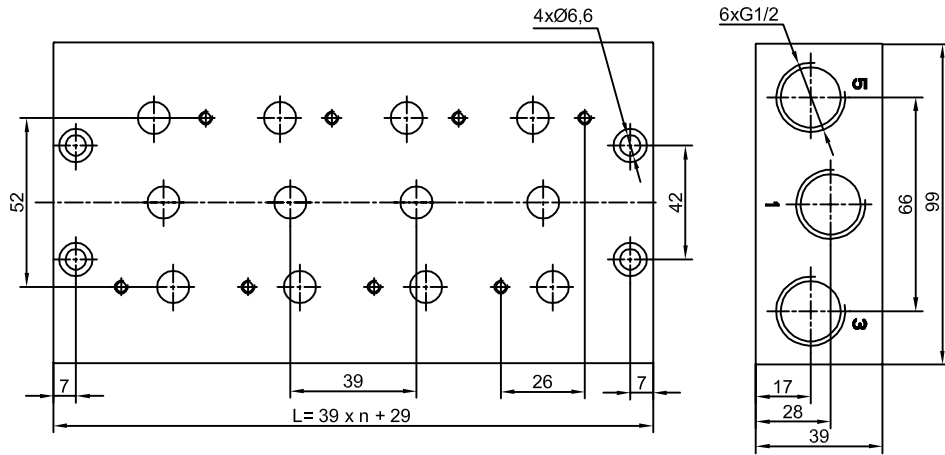



## ORDER NUMBERS

Connection thread in the central plates	Connection thread in the side plates	Size	Valve control type	Order number
G1/8	G1/4	1	electromagnetic, mechanical	26.0101.5218nn
G1/4	G3/8			26.0101.5214nn
G1/8	G1/4		pneumatic	26.0101.5218nnP
G1/4	G3/8			26.0101.5214nnP
G1/4	G3/8	2	electromagnetic, mechanical	26.0102.5214nn
G3/8	G1/2			26.0102.5238nn
G1/4	G3/8		pneumatic	26.0102.5214nnP
G3/8	G1/2			26.0102.5238nnP

## ORDERING PROCEDURE

In your order, please specify the name and function of the valve, connection thread, order number, (nn - number of valves mounted on the plate) and number of pieces (order numbers for DTE, DTP, DTM valves can be found on pages 273, 277, 278, 295, 296, 301, 302, 319, 320, 327, 328), e.g.:

**Subplate G3/8 n=04 no. 26.0102.523804 1 pc.**

## SUBPLATE for DTE, DTM and DTP 5/2, 5/3 VALVES

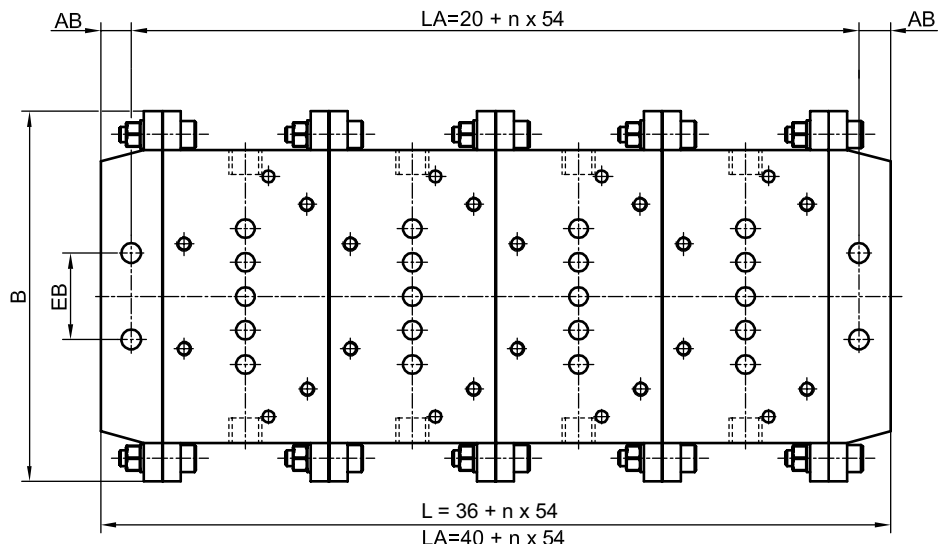

Size	AB	B	EB
1	10	120	28
2	10	165	34

# SEGMENTED SUBPLATE

for distribution valves series DTE, DTP and DTM



## SUBPLATE for DTE, DTM and DTP 5/2, 5/3 VALVES

### SIDE PLATES

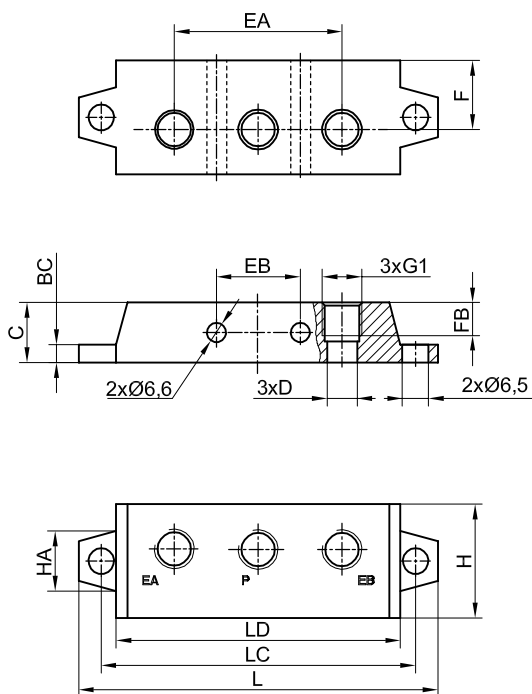

### CENTRAL PLATE

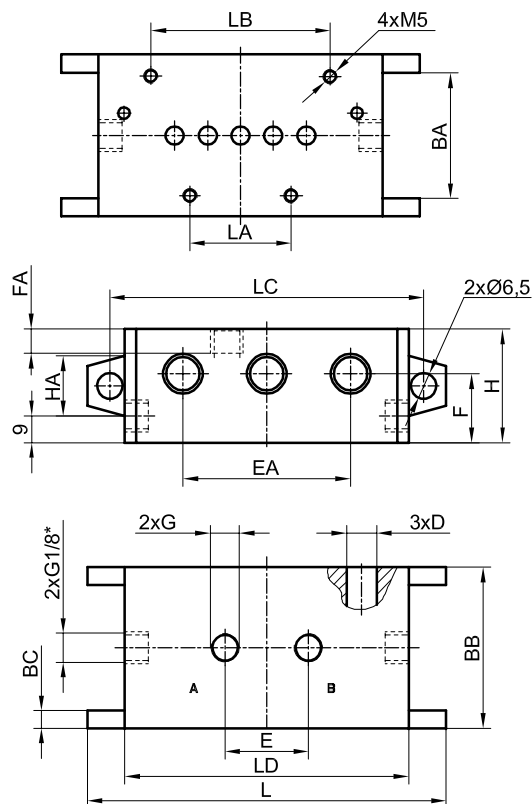

Size	G	G1	BA	BB	BC	C	D	E	EA	EB	F	FA	FB	H	HA	L	LA	LB	LC	LD
1	G1/8	G1/4	40	54	6	20	10	28	56	28	23	8	11	38	20	120	34	60	105	95
	G1/4	G3/8	40	54	6	20	10	28	56	28	23	8	11	38	20	120	34	60	105	95
2	G1/4	G3/8	42	54	8	20	15	32	67	34	23	11	12	46	20	165	48	86	152	138
	G3/8	G1/2	42	54	8	20	15	32	67	34	23	11	12	46	20	165	48	86	152	138

\*) Applies only to central plates for DTP valves



### SUBPLATE 3/2, 3/3, G1/4

Subplate for valve	Order number
series DTE, DTM	25.0101.323314
series DTP	25.0101.323314P

### SUBPLATE 3/2, 3/3, G3/8

Subplate for valve	Order number
series DTE, DTM	25.0101.323338
series DTP	25.0101.323338P

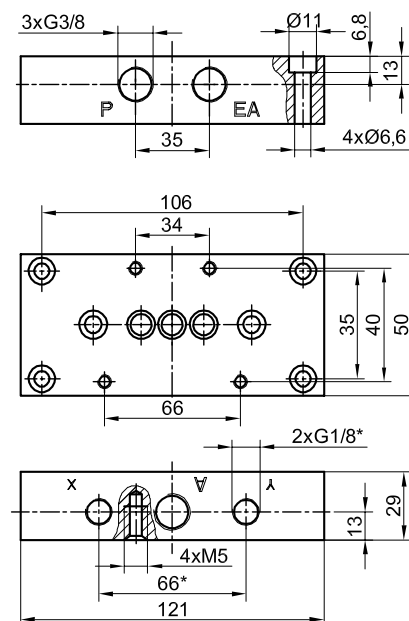
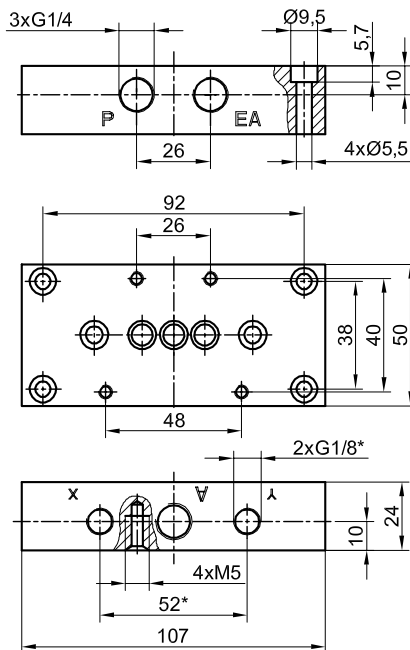

\* Applies to DTP valve subplates

# SUBPLATE

for distribution valves series DTE, DTP and DTM



## SUBPLATE 3/2, 3/3, G1/2

Subplate for valve	Order number
series DTE, DTM	25.0101.323312
series DTP	25.0101.323312P

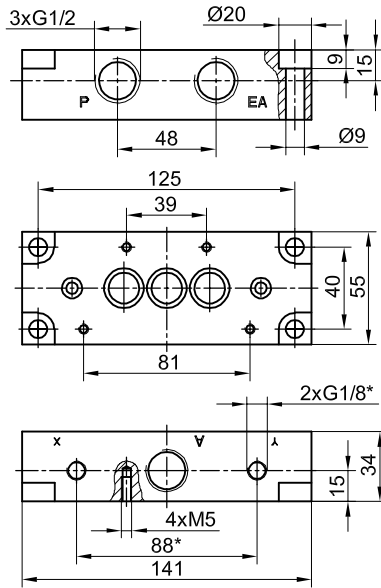

## SUBPLATE 3/2, 3/3, G3/4

Subplate for valve	Order number
series DTE, DTM	25.0101.323334
series DTP	25.0101.323334P

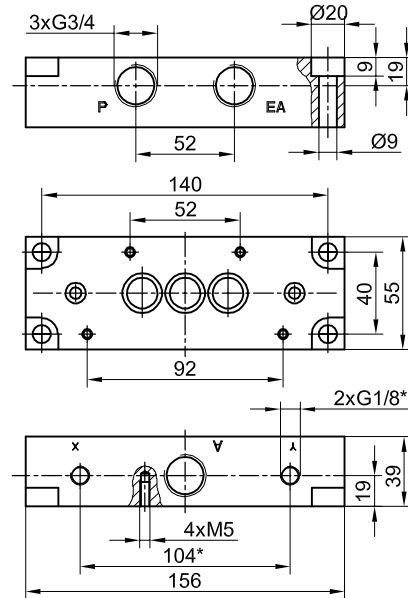

## SUBPLATE 5/2, 5/3, G1/8, G1/4

Connection thread	Subplate for valve	Order number
G1/8	series DTE, DTM	25.0102.525318
G1/8	series DTP	25.0102.525318P
G1/4	series DTE, DTM	25.0102.525314
G1/4	series DTP	25.0102.525314P

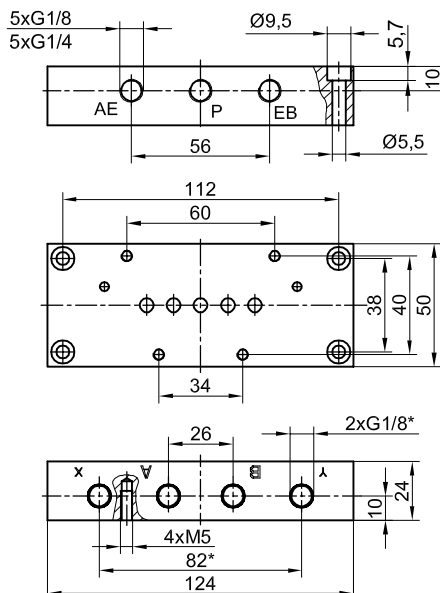

## SUBPLATE 5/2, 5/3, G1/4, G3/8

Connection thread	Subplate for valve	Order number
G1/4	series DTE, DTM	25.0103.525314
G1/4	series DTP	25.0103.525314P
G3/8	series DTE, DTM	25.0103.525338
G3/8	series DTP	25.0103.525338P

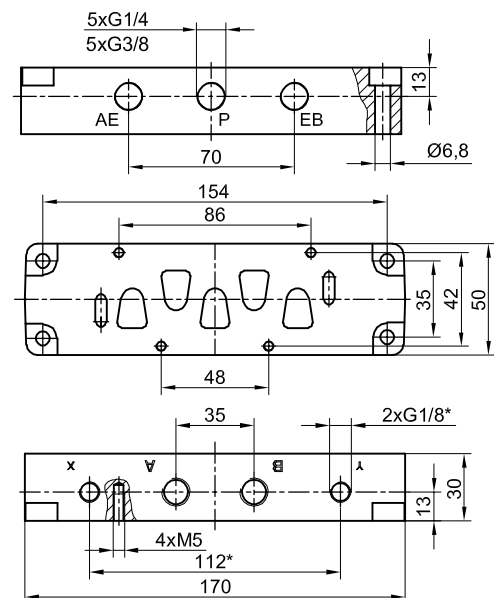

\* Applies to DTP valve subplates

## SUBPLATE 5/2, 5/3, G1/2, G3/4

Connection thread	Subplate for valve	Order number
G1/2	series DTE, DTM	25.0104.525312
G1/2	series DTP	25.0104.525312P
G3/4	series DTE, DTM	25.0104.525334
G3/4	series DTP	25.0104.525334P

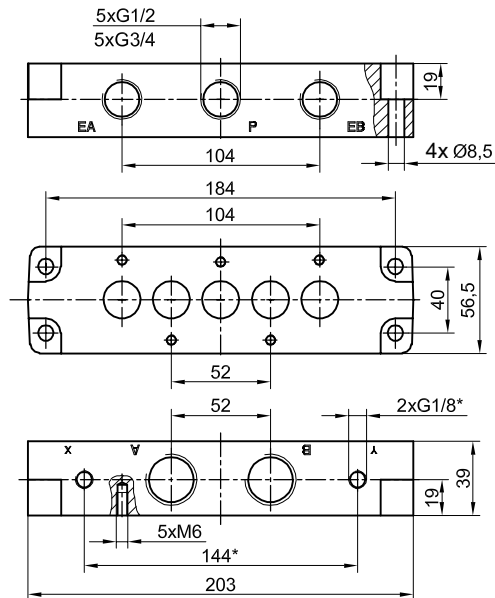

## ORDERING PROCEDURE

In your order, please specify the name of the plate, connection thread, order number and the number of pieces, e.g.:

**Subplate for 5/2 DTP valve, G3/8 no. 25.0103.525338P 1 pc.**

\* Applies to DTP valve subplates





## SUBPLATE FOR DISTRIBUTION VALVE

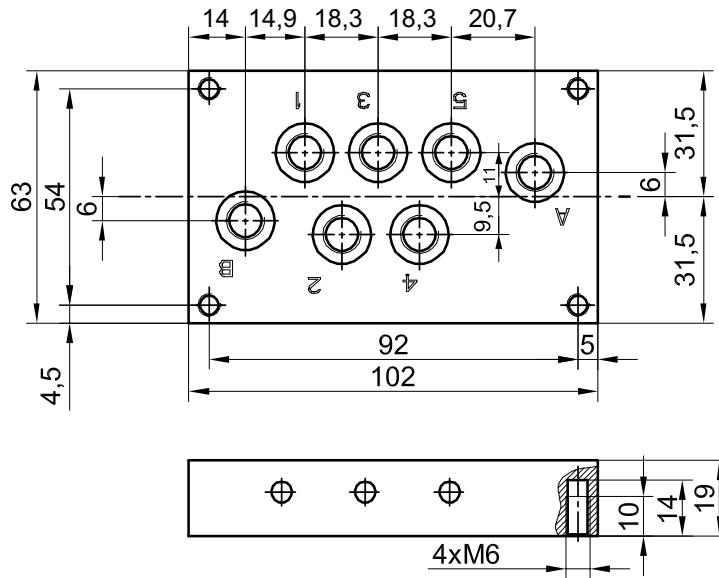

## ORDER NUMBERS

Number of paths in the plate-mounted distribution valves	Valve connection thread	Nominal diameter	Order number of the subplate
5-way	G1/8	Ø5	28.2525.5218

## ORDERING PROCEDURE

In your order, please specify the name of the plate, connection thread, order number and the number of pieces, e.g.:

- 1) Subplate for distribution valve 5/2 G1/8 no. 28.2525.5218 1 pc.
- 2) Distribution valve 5/2 G1/8 pneumatically operated with spring support, no. 28.0025.5218 1 pc.

# SUBPLATES

for ISO E and ISO P distribution valves



## SUBPLATE FOR ISO E AND ISO P VALVES

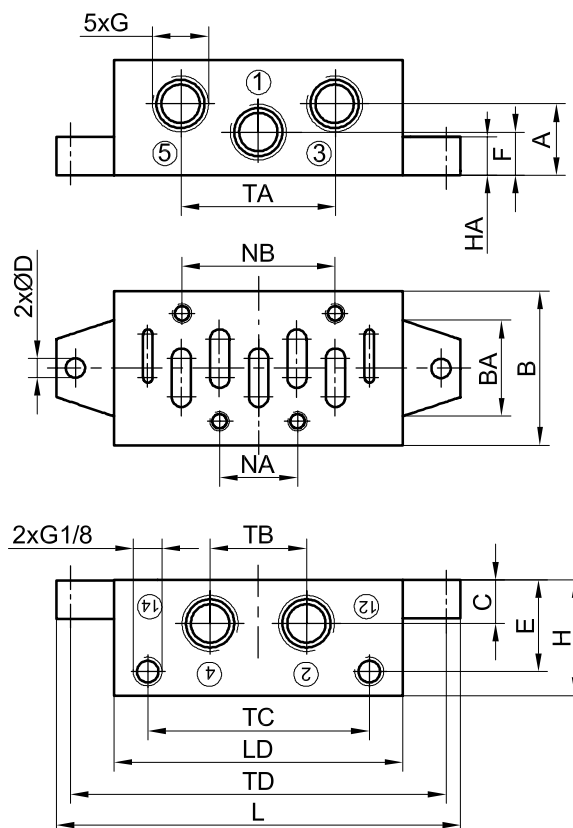

E	F	H	HA	L	LD	NA	NB	TA	TB	TC	TD
25	13	34	10	124	100	24	48	52	26	68	112

## ORDER NUMBERS

Number of paths in the plate-mounted distribution valves	Connection thread	ISO size	Order number
5-way	G1/4	2	25.0302.525314P
	G3/8		25.0302.525338P

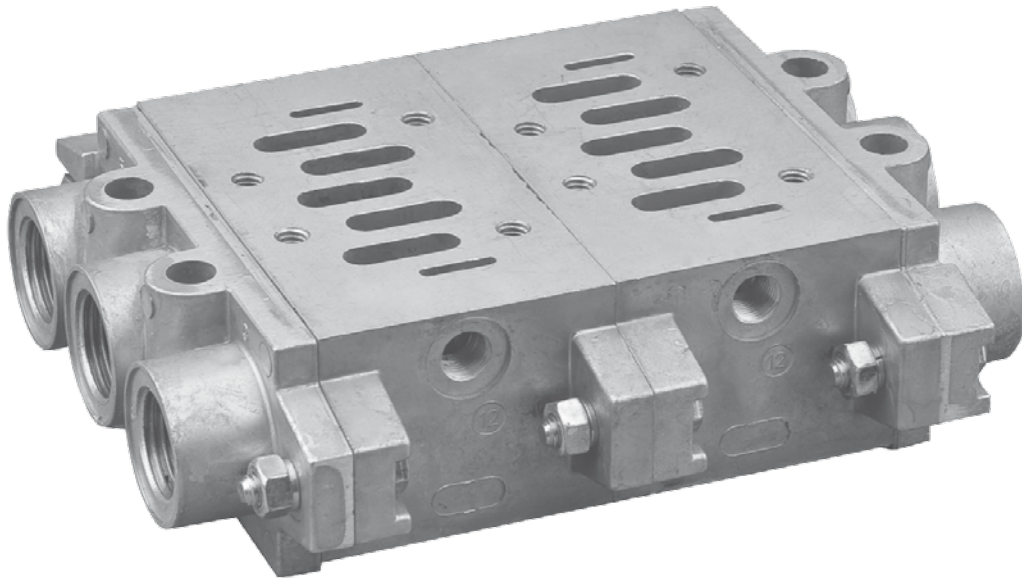

## ORDER NUMBERS

Connection thread in central plates	Connection thread in side plates	ISO size	Order number
G1/4	G3/8	2	26.0302.5214nn
G3/8	G1/2		26.0302.5238nn

## ORDERING PROCEDURE

In your order, please specify the name and function of the valve, connection thread, order number, (nn - number of valves mounted on the plate) and the number of pieces (order numbers for ISO valves can be found on pages 271, 272, 293), e.g.:

**Subplate G3/8 n=04 no. 26.0302.523804 1 pc.**

## SUBPLATE FOR ISO E, ISO P 5/2, 5/3 VALVES

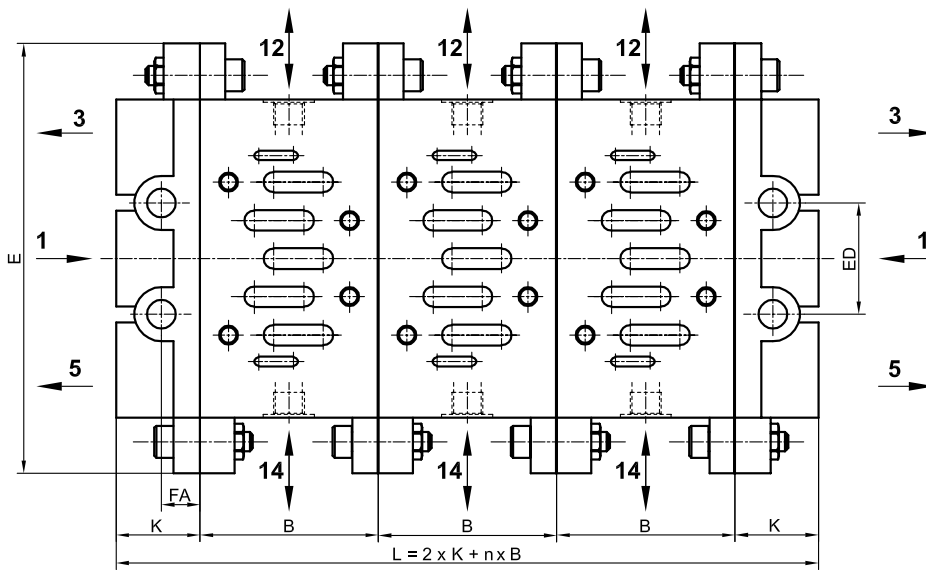

Size	B	E	ED	FA	K
1	43	110	28	11	22
2	56	135	35	12	26
3	71	180	45	15	30

# SEGMENTED SUBPLATES

for ISO E and ISO P distribution valves



## SIDE PLATES

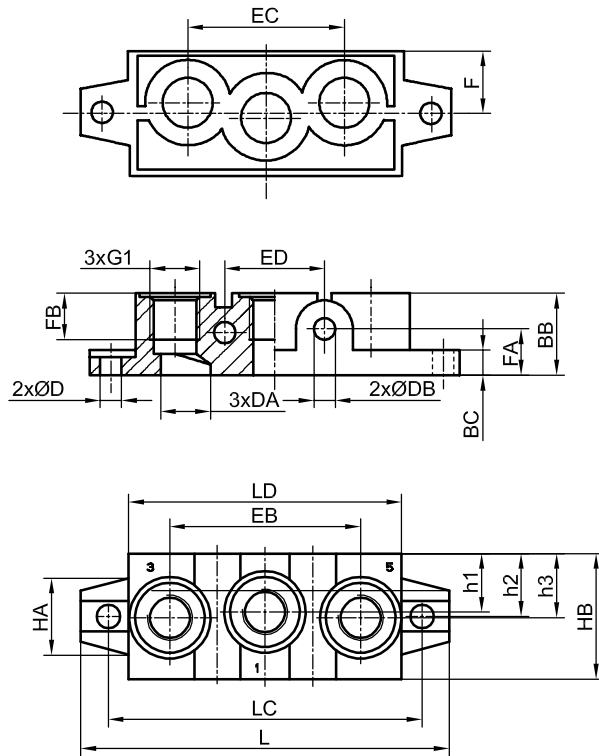

## CENTRAL PLATE

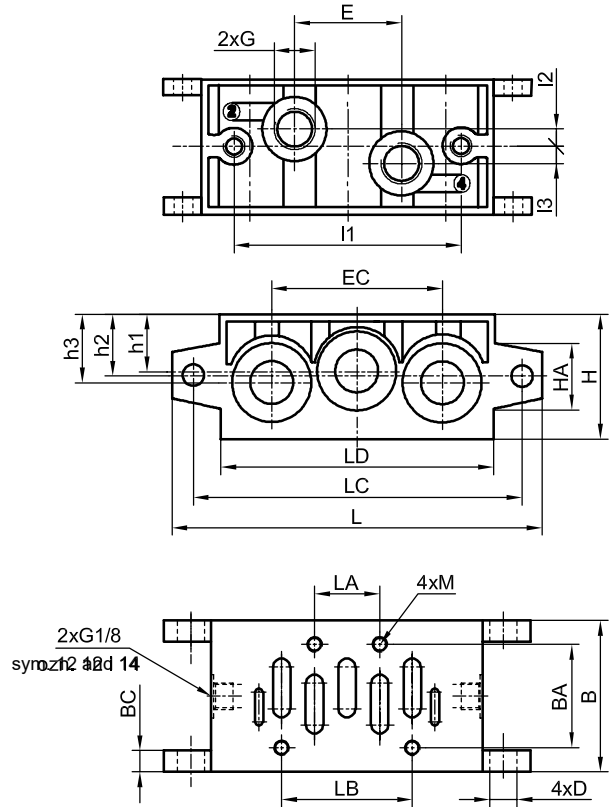

Size	G	G1	B	BA	BB	BC	D	DA	DB	EB	EC	ED	FA	FB	H	HA	HB	h1	h2	h3	L	LA	LB	LC	LD	I1	I2	I3
1	G1/8	G1/4	43	28	22	6	5.5	11.6	7	56	47.5	28	11	11.5	44	25	46	22	22	25	110	18	36	98	82	68	7.5	1.5
	G1/4	G3/8	43	28	22	6	5.5	15.1	7	56	47.5	28	11	12	44	25	46	22	22	25	110	18	36	98	82	68	7.5	1.5
2	G1/4	G3/8	56	38	26	8	6.6	15.1	9	70	64	35	12	12	45	28	47	21.5	22.5	23.5	135	24	48	115	100	86	6	5
	G3/8	G1/2	56	38	26	8	6.6	19	9	70	64	35	12	15	45	28	47	21.5	22.5	23.5	135	24	48	115	100	86	6	5
3	G3/8	G1/2	71	48	30	8	9	24.5	12	90	85	45	15	17	54	30	56	26.5	27	28	180	32	64	158	130	114	9	6
	G1/2	G3/4	71	48	30	8	9	19	12	90	85	45	15	15	54	30	56	26.5	27	28	180	32	64	158	130	114	9	6

## DTE SERIES

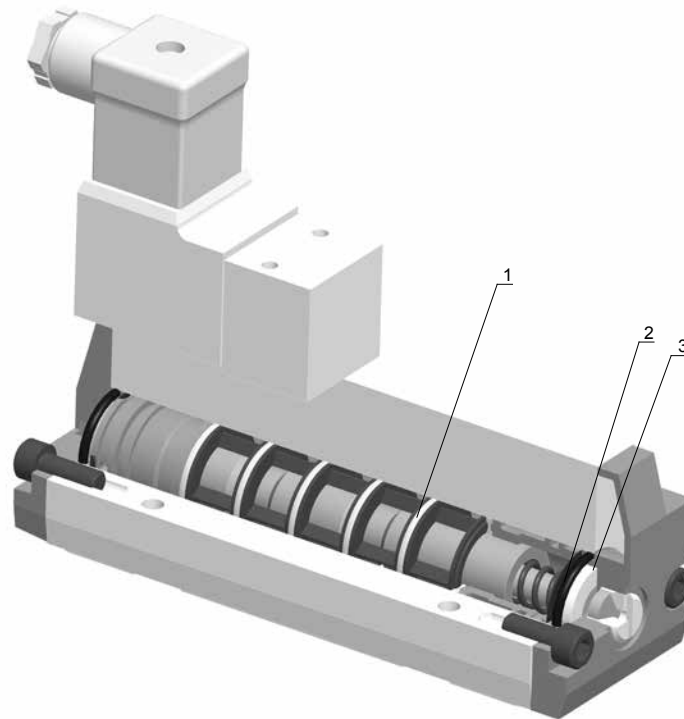

Position	1	2	3	Repair kit number	
Spare part name	Slider gasket	O-ring	Stop	5-way	3-way
Order number	29.0105	19.0001.0008	29.0103	29.2201.5KN	29.2201.3KN
<b>Number of pieces in a</b>					
5-way valve	6	2	2	1	-
3-way valve	4	2	2	-	1

## ORDERING PROCEDURE

In your order, please specify:  
the name of the spare part or repair kit, order number and the number of pieces, e.g.:

**Slider gasket for DTE valve no. 29.0105 1 pc.**

# REPAIR KITS

for valves compliant with ISO 5599/1



## ISO E SERIES

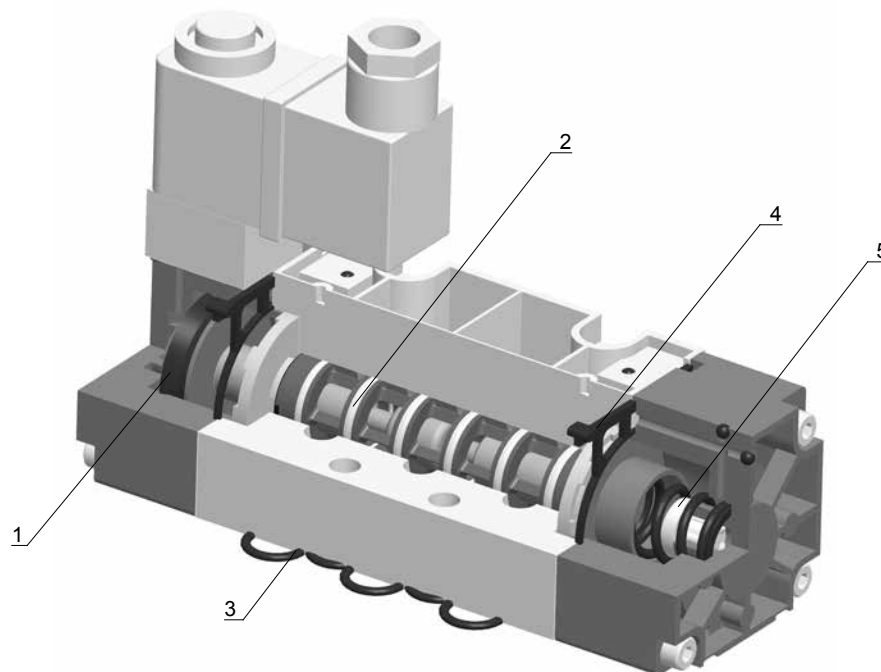

Position	1	2	3	4	5	Repair kit number
Spare part name	Piston gasket	Slider gasket	Plate gasket	Cover gasket	Stop	
Order number	29.0306	29.0304	29.0307	29.0305	29.0314.01	29.0310.KN
<b>Number of pieces in the</b>						
5-way valve	2	6	1	2	2	1

## ORDERING PROCEDURE

In your order, please specify:  
the name of the spare part or repair kit, order number and the number of pieces, e.g.:

**Piston seal for valve compliant with ISO no. 29.0306 1 pc.**

## ZEM SERIES

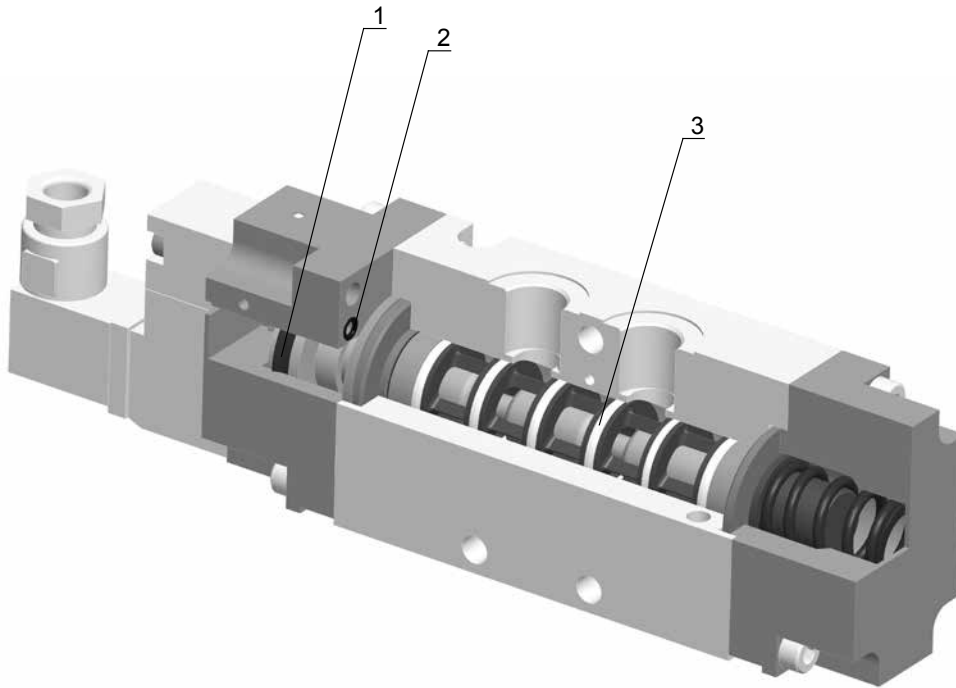

Position	1	2	3	Repair kit number	
Spare part name	Piston gasket	O-ring	Slider gasket	5-way	3-way
Order number	19.018D.04	19.0001.0033	29.0304	29.1701.5KN	29.1701.3KN
<b>Number of pieces in the</b>					
5-way valve	2	2	6	1	-
3-way valve	2	2	4	-	1

## ORDERING PROCEDURE

In your order, please specify:  
the name of the spare part or repair kit, order number and the number of pieces, e.g.:

**Slider gasket for ZEM valve no. 29.0304 1 pc.**



## ZEM NAMUR SERIES

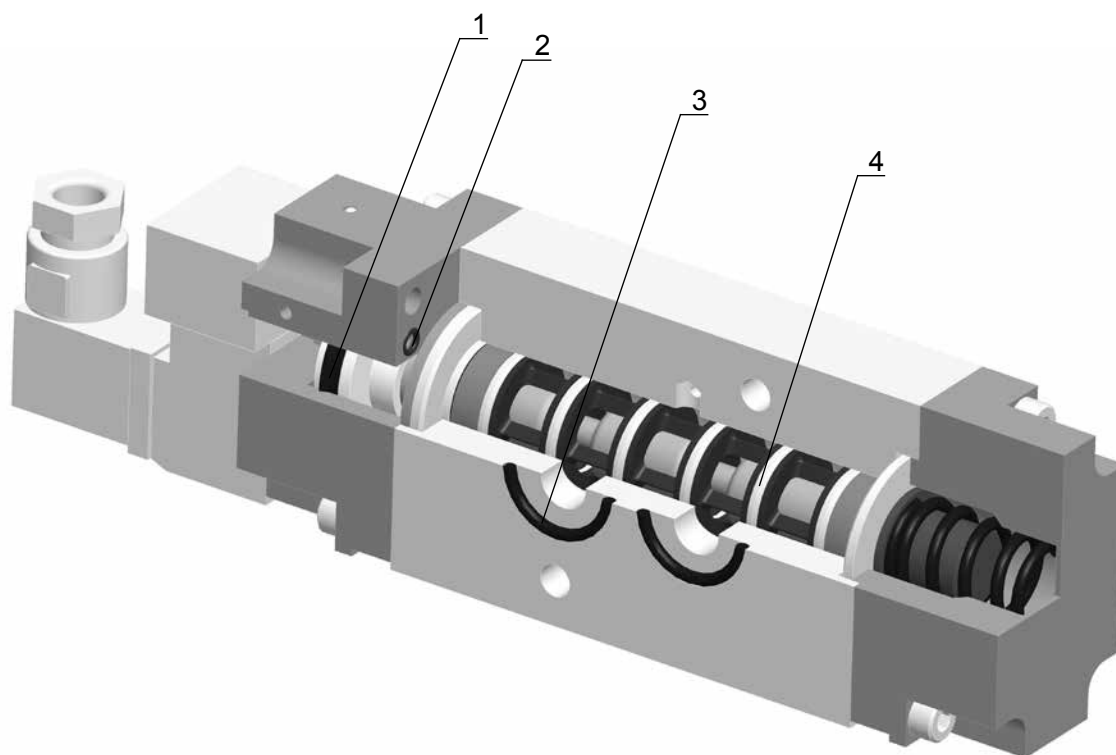

Position	1	2	3	4	Repair kit number	
Spare part name	Piston seal	O-ring	O-ring	Slider gasket	5-way	3-way
Order number	19.018D.04	19.0001.0033	19.0001.0006	29.0706.02	29.2214.5KN	29.2214.3KN
<b>Number of pieces in the</b>						
5-way valve	2	2	2	6	1	-
3-way valve	2	2	2	4	-	1

## ORDERING PROCEDURE

In your order, please specify:  
the name of the spare part or repair kit, order number and the number of pieces, e.g.:

**Slider gasket for ZEM NAMUR valve no. 29.0304 1 pc.**

## ZMG SERIES

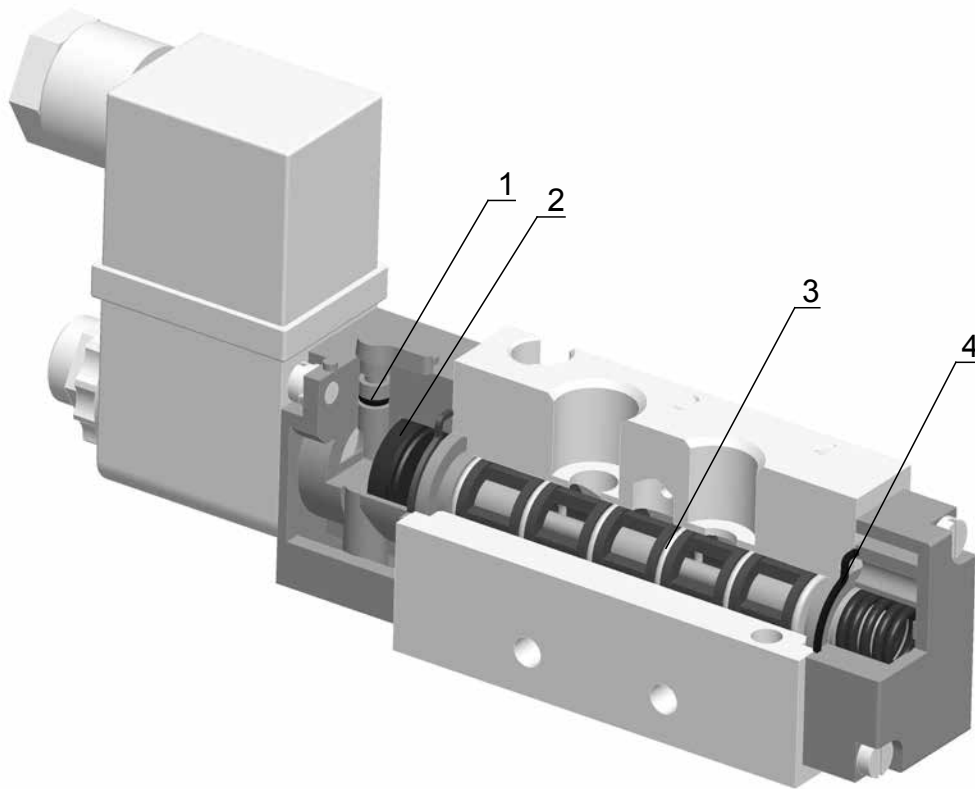

Position	1	2	3	4	Repair kit number	
Spare part name	O-ring	Piston gasket	Slider gasket	Cover gasket	5-way	3-way
Order number	19.0001.0033	19.018B.04	29.0706.02	29.0706.01	29.2207.5KN	29.2207.3KN
<b>Number of pieces in the</b>						
5-way valve	2	2	6	2	1	-
3-way valve	2	2	4	2	-	1

## ORDERING PROCEDURE

In your order, please specify:  
the name of the spare part or repair kit, order number and the number of pieces, e.g.:

**Slider gasket for ZMG valve no. 29.0706.02 1 pc.**

## ZMG NAMUR SERIES

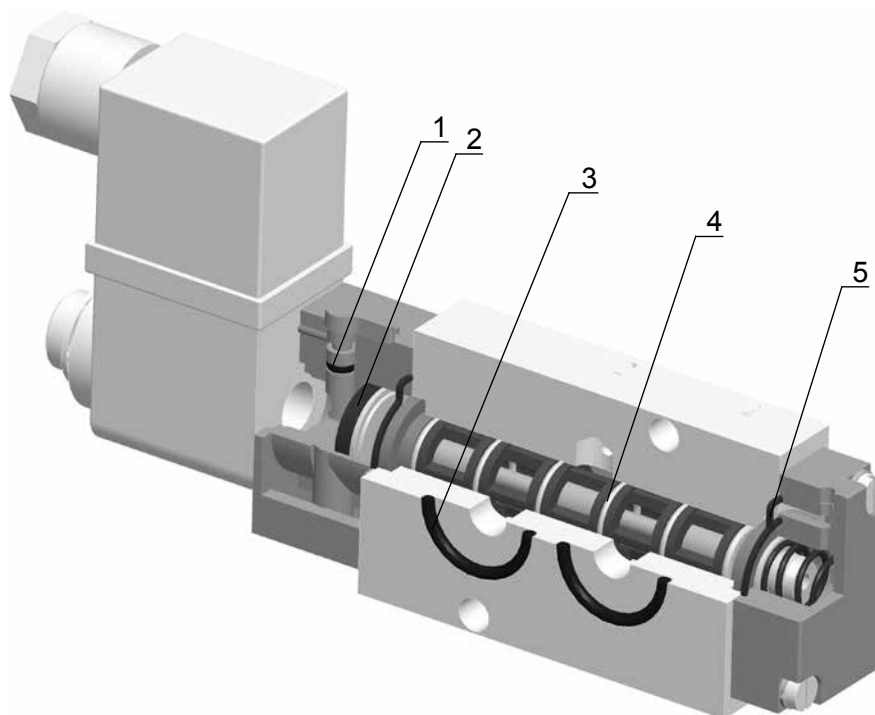

Position	1	2	3	4	5	Repair kit number
Spare part name	O-ring	Piston seal	O-ring	Slider gasket	Cover gasket	
Order number	19.0001.0033	19.018B.04	19.0001.0006	29.0706.02	29.0706.01	29.2204.5KN
<b>Number of pieces in the</b>						
5-way valve	2	2	2	6	2	1

## ORDERING PROCEDURE

In your order, please specify:  
the name of the spare part or repair kit, order number and number of pieces, e.g.

**Slider gasket for ZMG NAMUR valve no. 29.0706.02 1 pc.**

## ZE SERIES

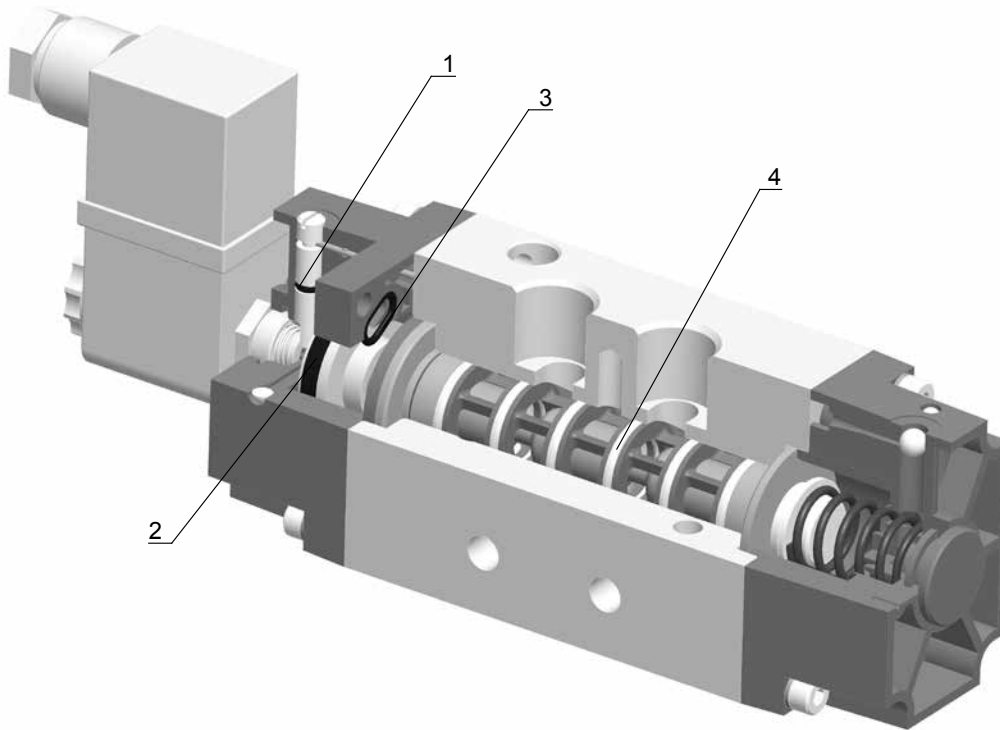

Position	1	2	3	4	Repair kit number	
Spare part name	O-ring	Piston gasket	O-ring	Slider gasket	5-way	3-way
Order number	19.0001.0091	19.018D.04	19.0001.0061	29.0304	29.2208.5KN	29.2208.3KN
<b>Number of pieces in the</b>						
5-way valve	2	2	2	6	1	-
3-way valve	2	2	2	4	-	1

## ORDERING PROCEDURE

In your order, please specify:  
the name of the spare part or repair kit, order number and the number of pieces, e.g.:

**Slider gasket for ZE valve no. 29.0304 1 pc.**

## ZDE SERIES

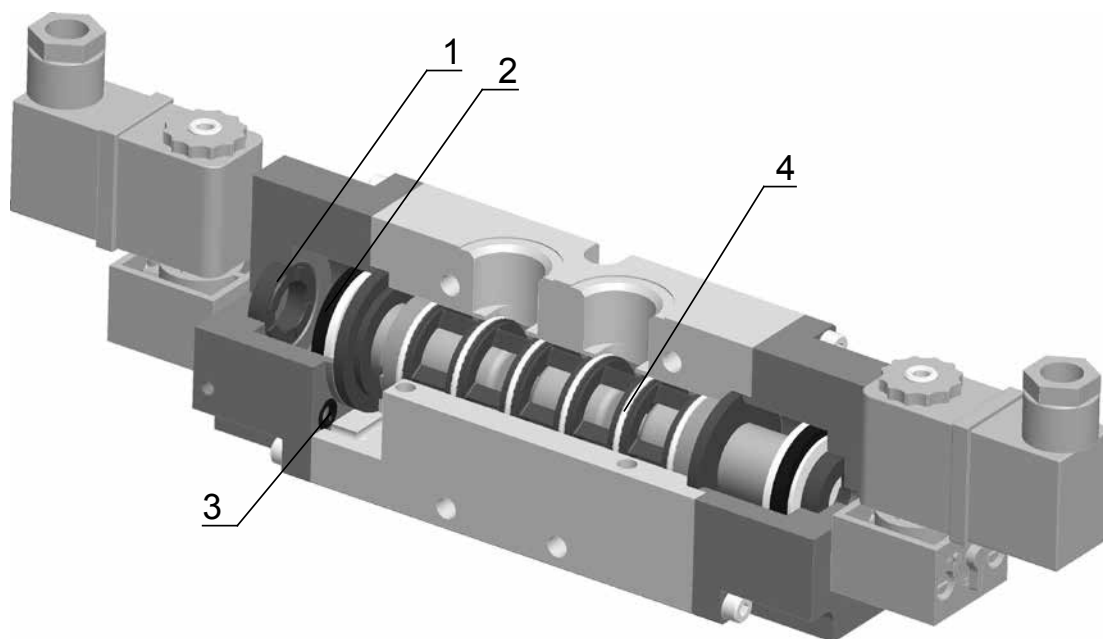

Position	1	2	3	4	Repair kit number	
Spare part name	Piston gasket	O-ring	Stop	Shaped gasket	5-way	3-way
Order number	19.019E.04	19.0001.0039	29.0103	29.0105	29.1901.5KN	29.1901.3KN
<b>Number of pieces in the</b>						
<b>5-way valve</b>	2	2	2	6	1	-
<b>3-way valve</b>	2	2	2	4	-	1

## ORDERING PROCEDURE

In your order, please specify:  
the name of the spare part or repair kit, order number and the number of pieces, e.g.:

**Piston gasket for ZDE valve no. 19.019E.04 1 pc.**

## DTP SERIES

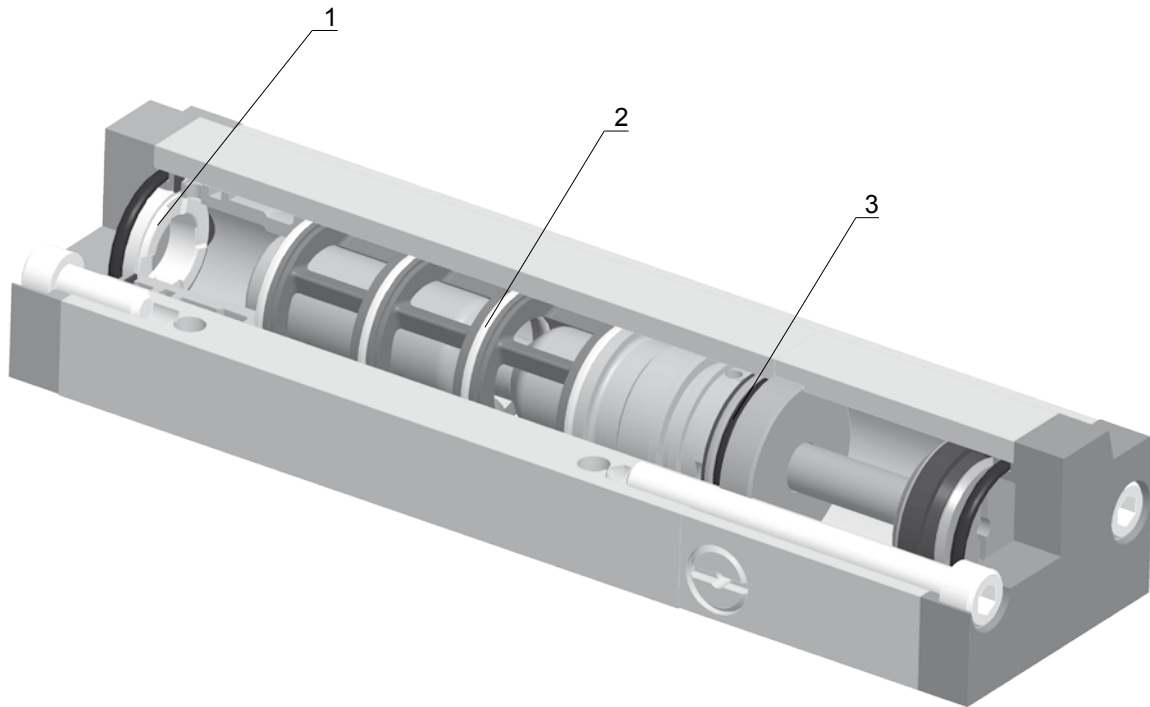

Position	1	2	3	Repair kit number	
Spare part name	Stop	Slider gasket	O-ring	5-way	3-way
Order number	29.0103	29.0105	19.0001.0008	29.2201.5KN	29.2201.3KN
<b>Number of pieces in the</b>					
5-way valve	2	6	2	1	-
3-way valve	2	4	2	-	1

## ORDERING PROCEDURE

In your order, please specify:  
the name of the spare part or repair kit, order number and the number of pieces, e.g.:

**Slider gasket for DTP valve no. 29.0105 1 pc.**

# REPAIR KITS

for valves compliant with ISO 5599/1



## ISO P SERIES

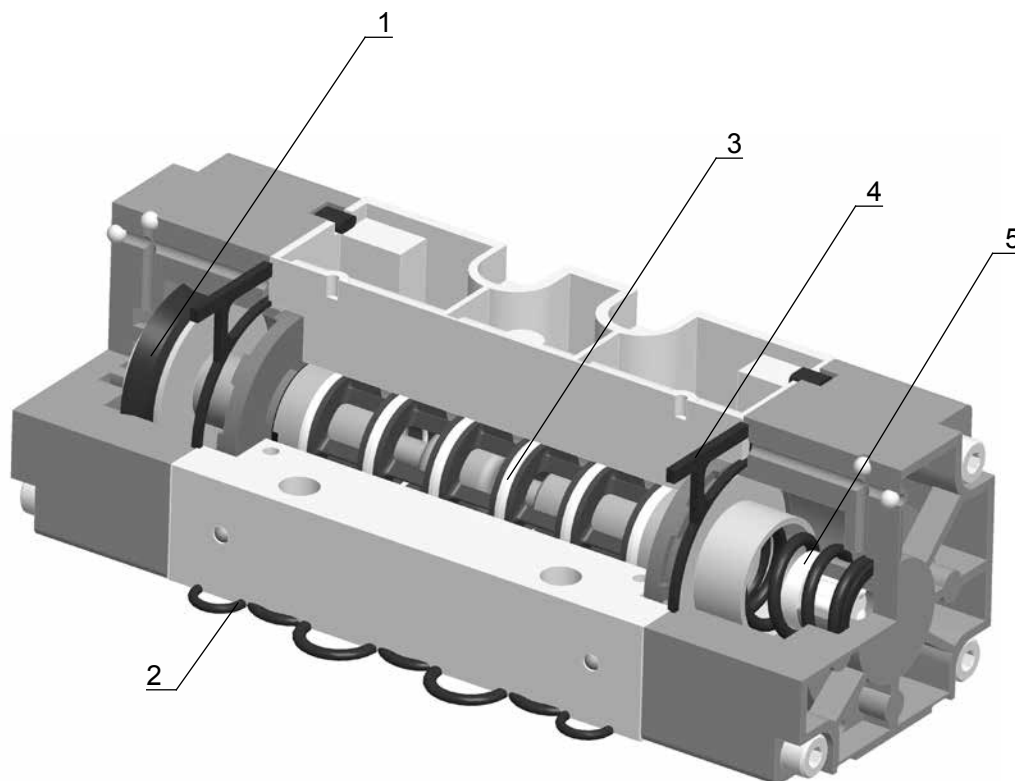

Position	1	2	3	4	5	Repair kit number
Spare part name	Piston gasket	Plate gasket	Slider gasket	Cover gasket	Stop	
Order number	29.0306	29.0307	29.0304	29.0305	29.0314.01	29.0312.KN
<b>Number of pieces in the</b>						
5-way valve	2	1	6	2	2	1

## ORDERING PROCEDURE

In your order, please specify:  
the name of the spare part or repair kit, order number and the number of pieces, e.g.:

**Piston seal for valve compliant with ISO no. 29.0306 1 pc.**

## ZMG P SERIES

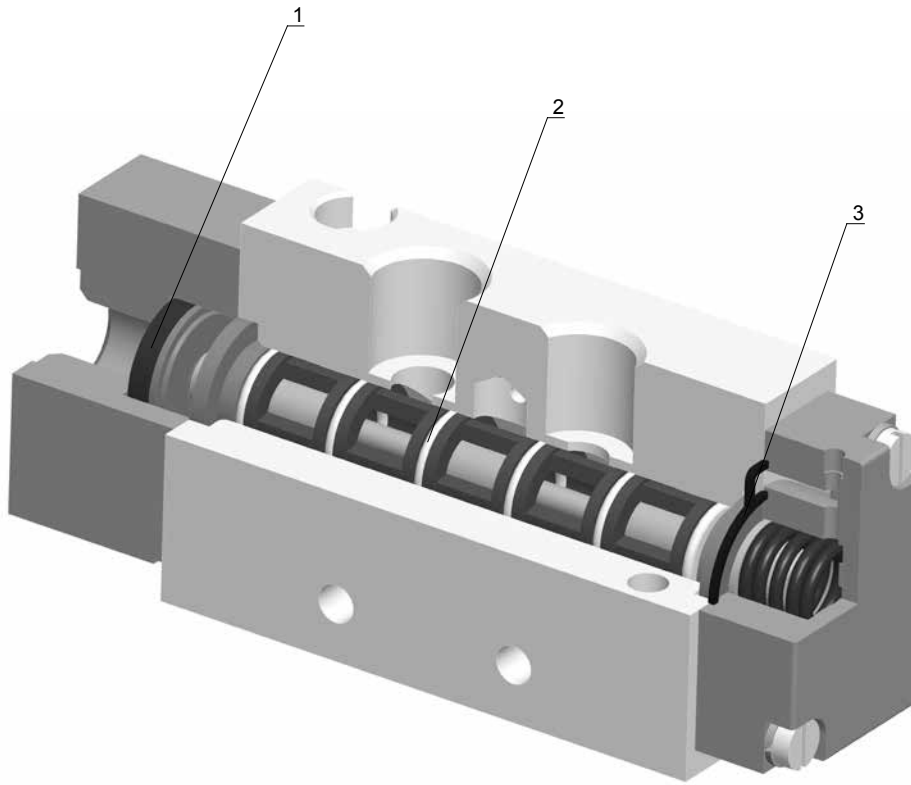

Position	1	2	3	Repair kit number	
Spare part name	Piston gasket	Slider gasket	Cover gasket	5-way	3-way
Order number	19.018B.04	29.0706.02	29.0706.01	29.2207.5KN	29.2207.3KN
<b>Number of pieces in the</b>					
5-way valve	2	6	2	1	-
3-way valve	2	4	2	-	1

## ORDERING PROCEDURE

In your order, please specify:  
the name of the spare part or repair kit, order number and the number of pieces, e.g.:

**Slider gasket for ZMG valve no. 29.0706.02 1 pc.**



# REPAIR KITS

for ZP valves



## ZP SERIES

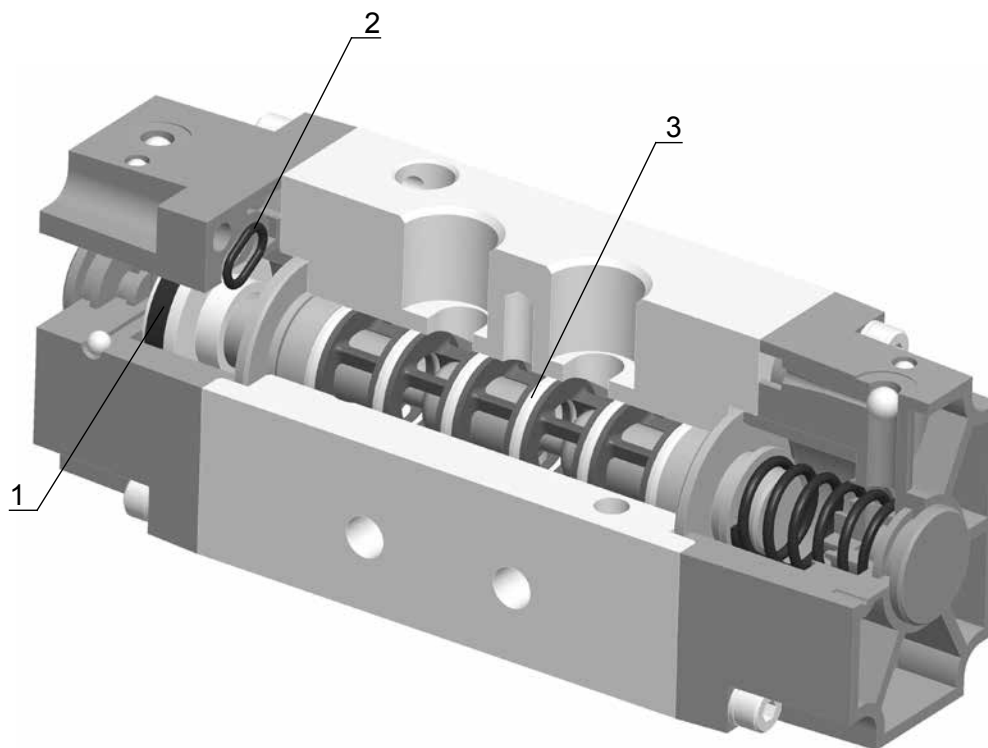

Position	1	2	3	Repair kit number	
<b>Spare part name</b>	Piston gasket	O-ring	Slider gasket	5-way	3-way
<b>Order number</b>	19.018D.04	19.0001.0061	29.0304	29.2208.5KN	29.2208.3KN
<b>Number of pieces in the</b>					
<b>5-way valve</b>	2	2	6	1	-
<b>3-way valve</b>	2	2	4	-	1

## ORDERING PROCEDURE

In your order, please specify:  
the name of the spare part or repair kit, order number and the number of pieces, e.g.:

**Piston gasket for ZP valve no. 19.018D.04 1 pc.**

## DTM SERIES

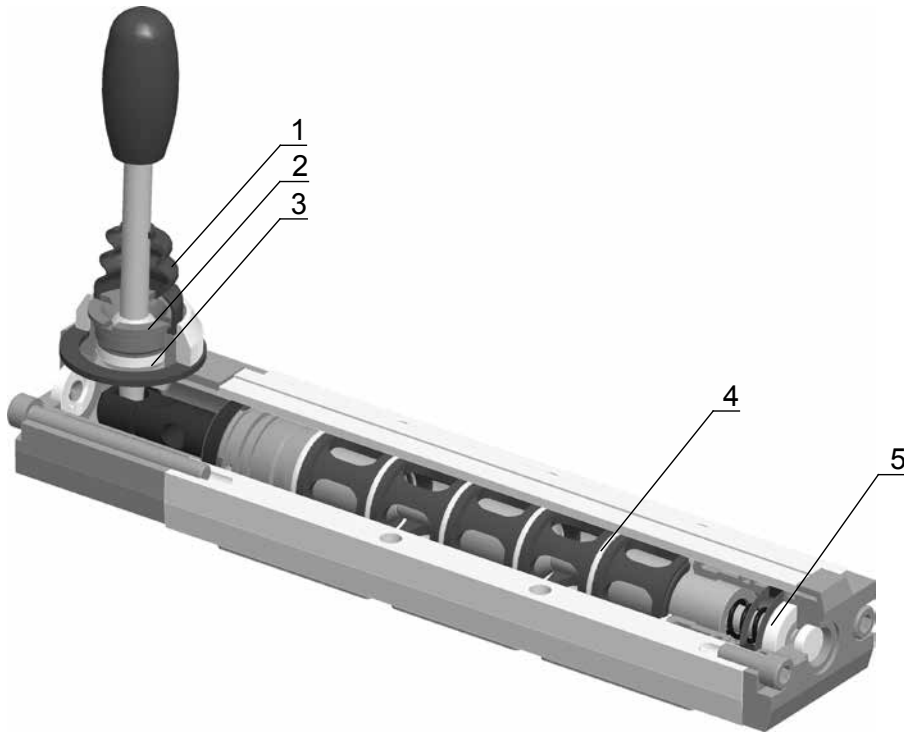

Position	1	2	3	4	5	Repair kit number	
Spare part name	Bellows	Top socket	Bottom socket	Slider gasket	Stop	5-way	3-way
Order number	29.0109	29.0108	29.0107	29.0105	29.0103	29.2401.5KND	29.2401.3KND
<b>Number of pieces in the</b>							
5-way valve	1	1	1	6	1	1	-
3-way valve	1	1	1	4	1	-	1

## ORDERING PROCEDURE

In your order, please specify:  
the name of the spare part or repair kit, order number and the number of pieces, e.g.:

**Slider gasket for lever operated DTM valve no. 29.0105 1 pc.**

# REPAIR KITS

for pull rod operated DTM valves



## DTM SERIES

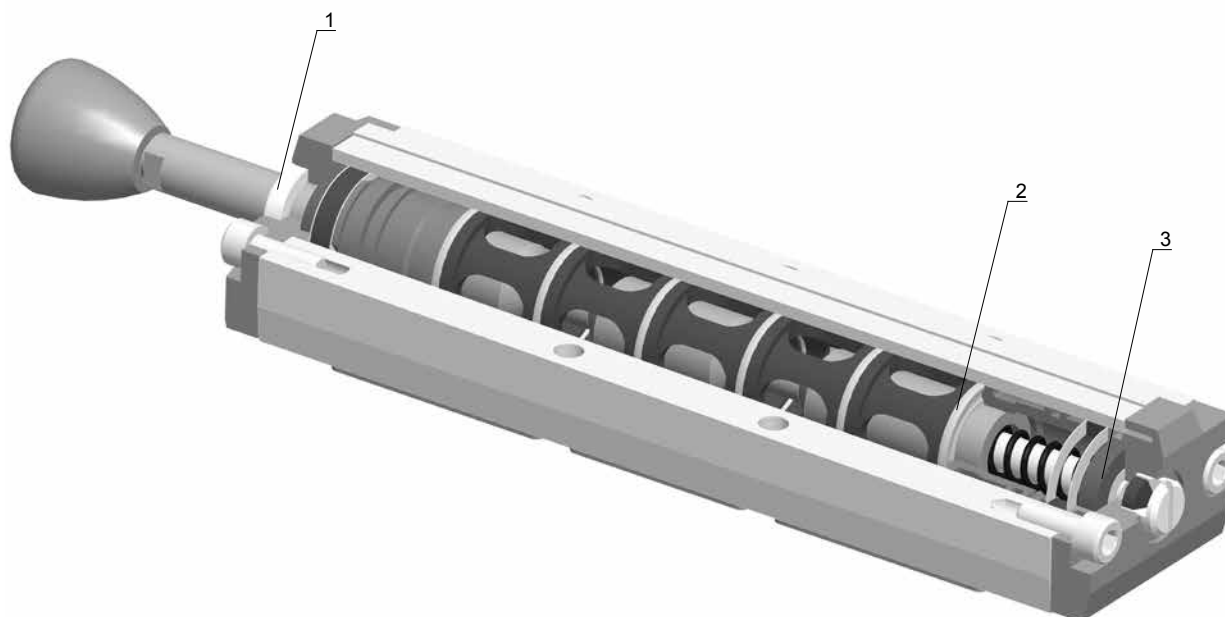

Position	1	2	3	Repair kit number	
Spare part name	Piston gasket	O-ring	Slider gasket	5-way	3-way
Order number	19.018D.04	19.0001.0061	29.0304	29.2208.5KN	29.2208.3KN
<b>Number of pieces in the</b>					
5-way valve	2	2	6	1	-
3-way valve	2	2	4	-	1

## ORDERING PROCEDURE

In your order, please specify:  
the name of the spare part or repair kit, order number and the number of pieces, e.g.:

**Slider gasket for pull rod operated DTM valve no. 29.0105 1 pc.**

## PLATE VALVE SERIES

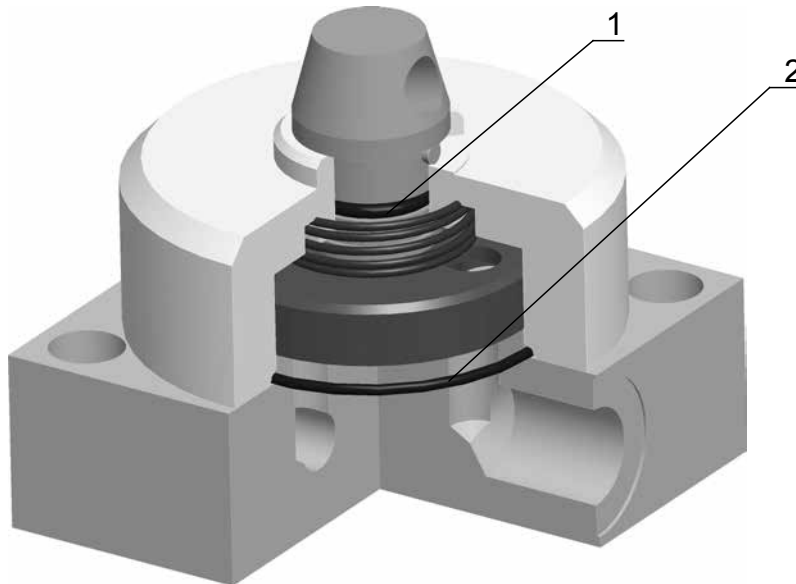

Position	1	2	Repair kit number	
Spare part name	O-ring	O-ring		3-way
Order number	19.0001.0032	19.0001.0082	29.2404.4KN	29.2208.3KN
<b>Number of pieces in the</b>				
4-way valve	1	1	1	-

## ORDERING PROCEDURE

In your order, please specify:  
the name of the spare part or repair kit, order number and the number of pieces, e.g.:

**Sealing ring for plate valve No. 19.0001.0032 1 pc.**

## PZR SERIES

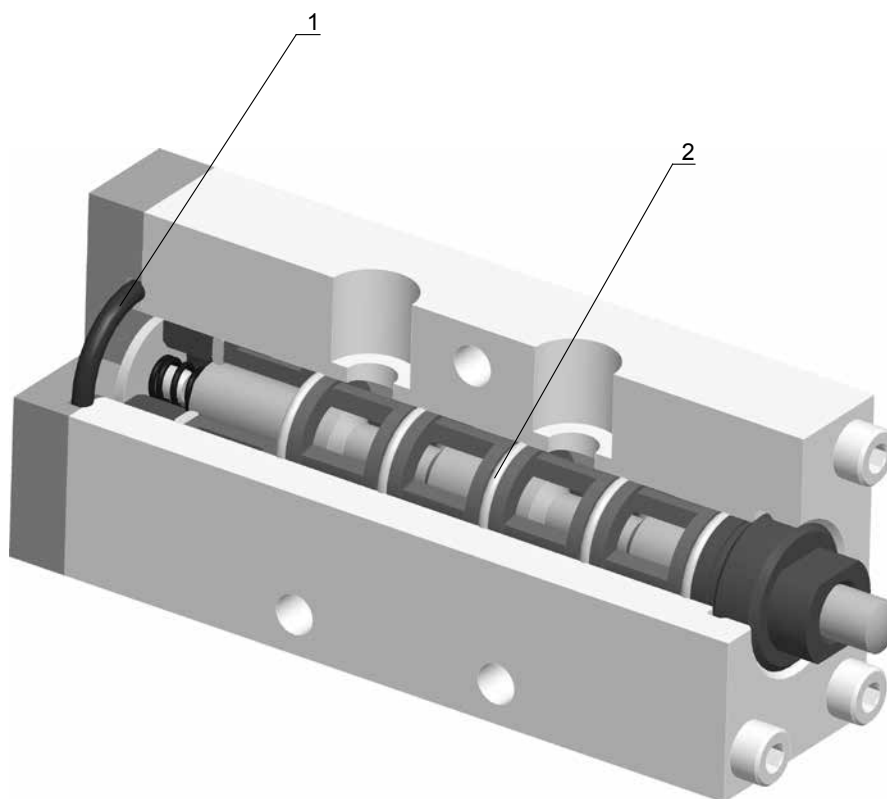

Position	1	2	Repair kit number	
Spare part name	O-ring	Slider gasket	5-way	3-way
Order number	19.0001.0052	29.0706.02	29.2426.5KN	29.2426.3KN
<b>Number of pieces in the</b>				
5-way valve	1	6	1	-
3-way valve	1	4	-	1

## ORDERING PROCEDURE

In your order, please specify:  
the name of the spare part or repair kit, order number and the number of pieces, e.g.:

**Slider seal for support distribution valve no. 29.0706.02 1 pc.**



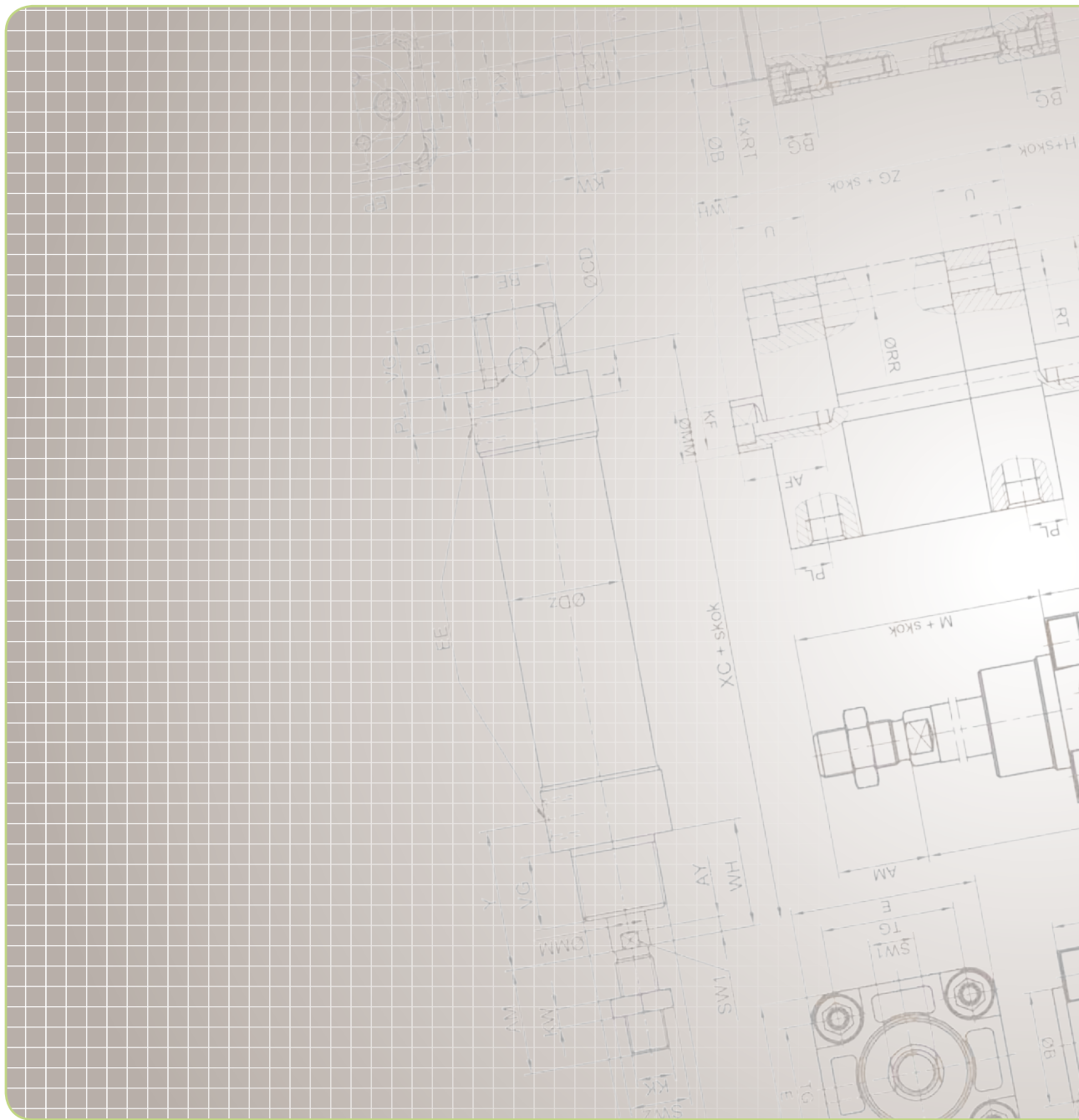

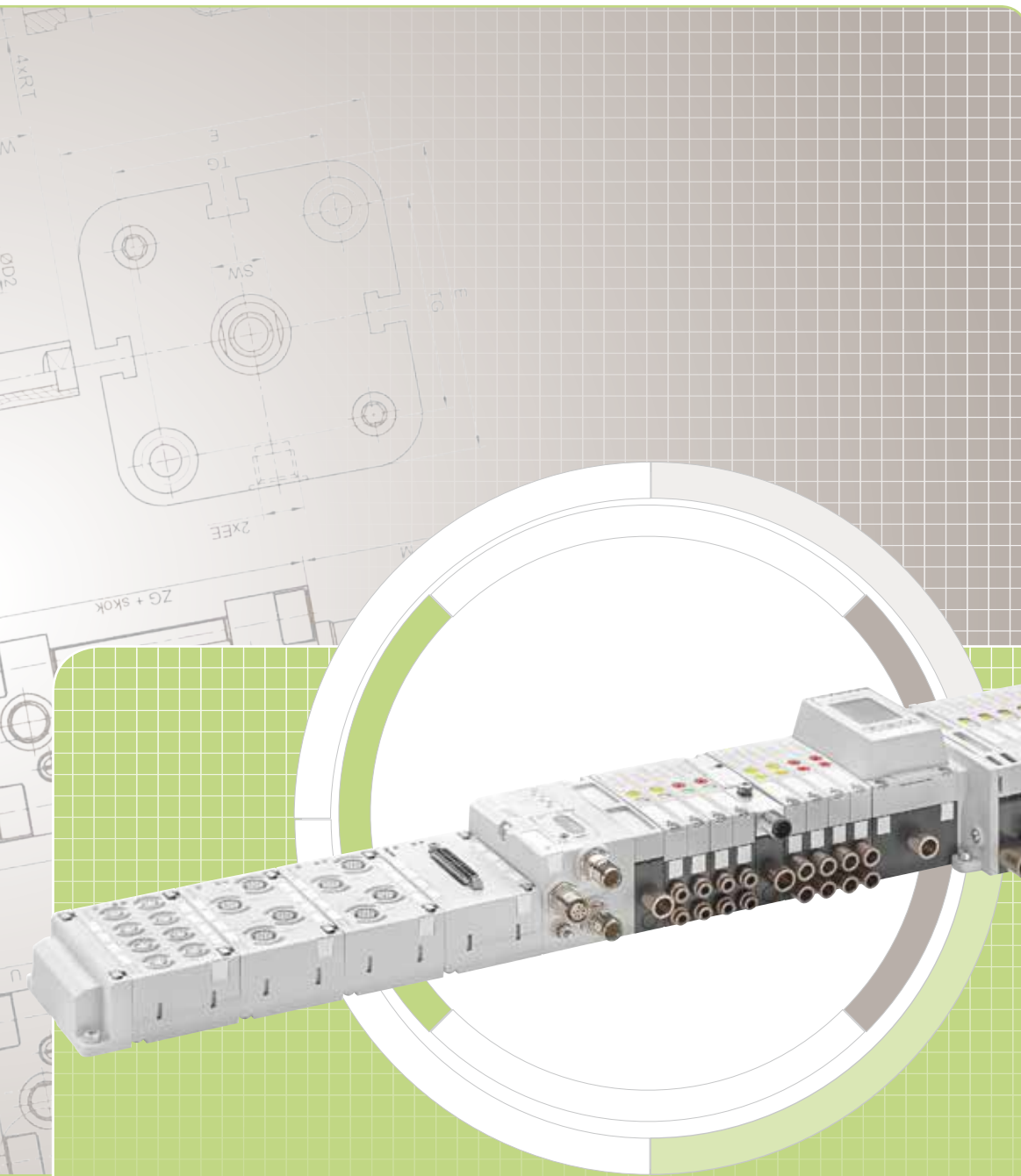

# VALVE TERMINALS





## TECHNICAL SPECIFICATIONS

<b>Operating pressure min/max:</b>	-0.9 bar / 10 bar
<b>Control pressure min/max:</b>	3 bar / 8 bar
<b>Ambient temperature min/max:</b>	from -10°C to +60°C
<b>Medium:</b>	compressed air
<b>Max. particle size:</b>	40 µm
<b>Oil content of the compressed air:</b>	0 mg/m <sup>3</sup> - 5 mg/m <sup>3</sup>
<b>Protection class with connection:</b>	IP65
<b>Electrical connectors:</b>	D-Sub 25-pin D-Sub 44-pin
<b>Max. number of solenoid coils:</b>	for 25-pin - 24 coils for 44-pin - 40 coils
<b>Operating voltage:</b>	DC 24 V ± 10%

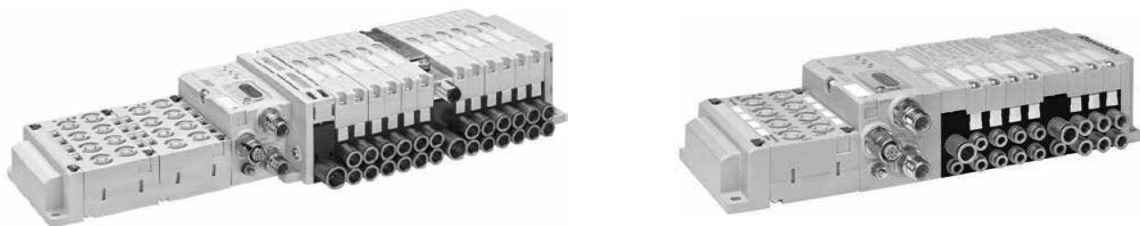

## GENERAL INFORMATION

Valve terminals of modular and compact design with Multipol D-SUB connection are used for mounting distribution valves with 5/2, 5/3, 2 x 2/2 and 2 x 3/2 functions, electromagnetically controlled. The valves are characterised by high flow parameters (nominal flow 300 or 700 l/min), while maintaining minimum assembly dimensions. The terminals are equipped with built-in noise reduction systems. The side plates have a common vent for all the valve paths. The pneumatic supply to the terminal is provided from the port marked 1 as in the side plates, and for a larger number of valves, additional supply plates are used to provide an adequate flow of compressed air.

The power supply to the solenoids is routed to one common connector, and the switching status of the valves is indicated by LED indicators which are an integral part of the solenoid valves. The valve terminals are configured according to customer requirements and are fully assembled and tested.

# VALVE TERMINALS

with multipol (D-SUB) connection



## VALVE TERMINAL AV03

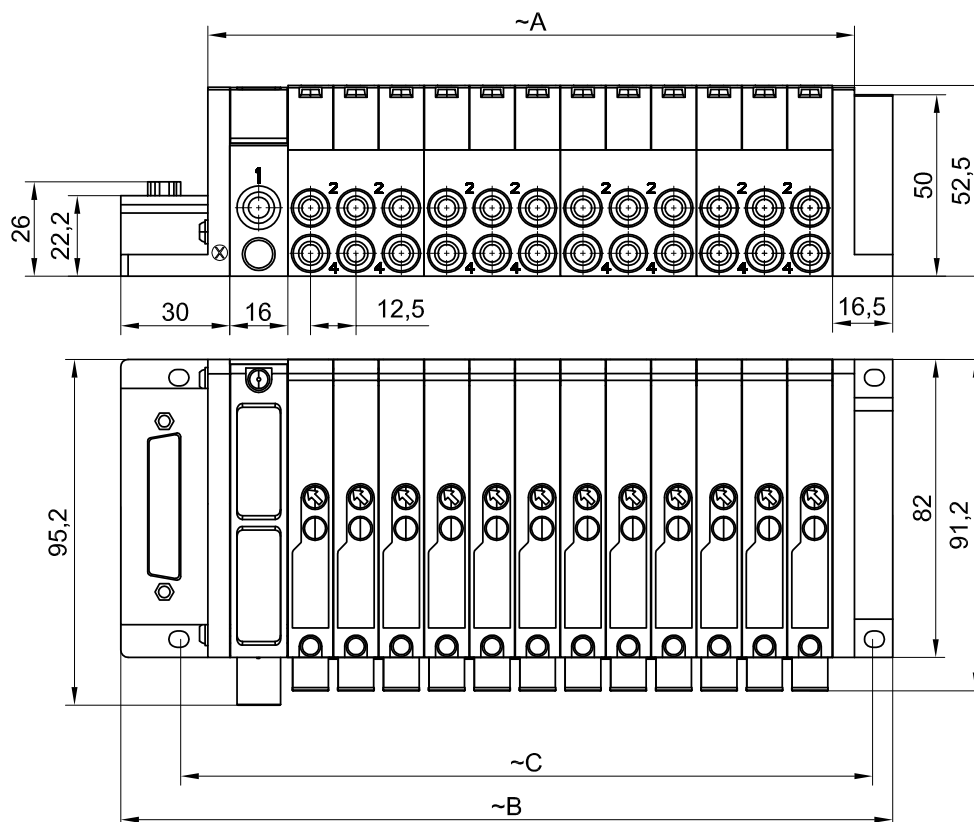

A = number of valve positions x 12.5 mm + number of supply plates x 16 mm + 12 mm

B = number of valve positions x 12.5 mm + number of supply plates x 16 mm + 46.5 mm

C = number of valve positions x 12.5 mm + number of supply plates x 16 mm + 25.5 mm

When determining the dimensions, consider the supply plate before the first valve.

R = limited preliminary control air outlet, plug connection Ø4 mm. Direction of connection: straight

X = external preliminary control, plug connection Ø4 mm. Direction of connection: straight

## AVAILABLE DIAMETERS FOR PLUG CONNECTIONS

Connector	Available diameters	Direction of connection
1	Ø4 mm, Ø6 mm and Ø8 mm	straight and 90° angle (interchangeable connectors)
2 and 4	Ø3 mm	90° angle
2 and 4	Ø4 mm and Ø6 mm	straight and 90° angle (interchangeable connectors)
3 and 5	Ø8 mm	straight

## VALVE TERMINAL AV05

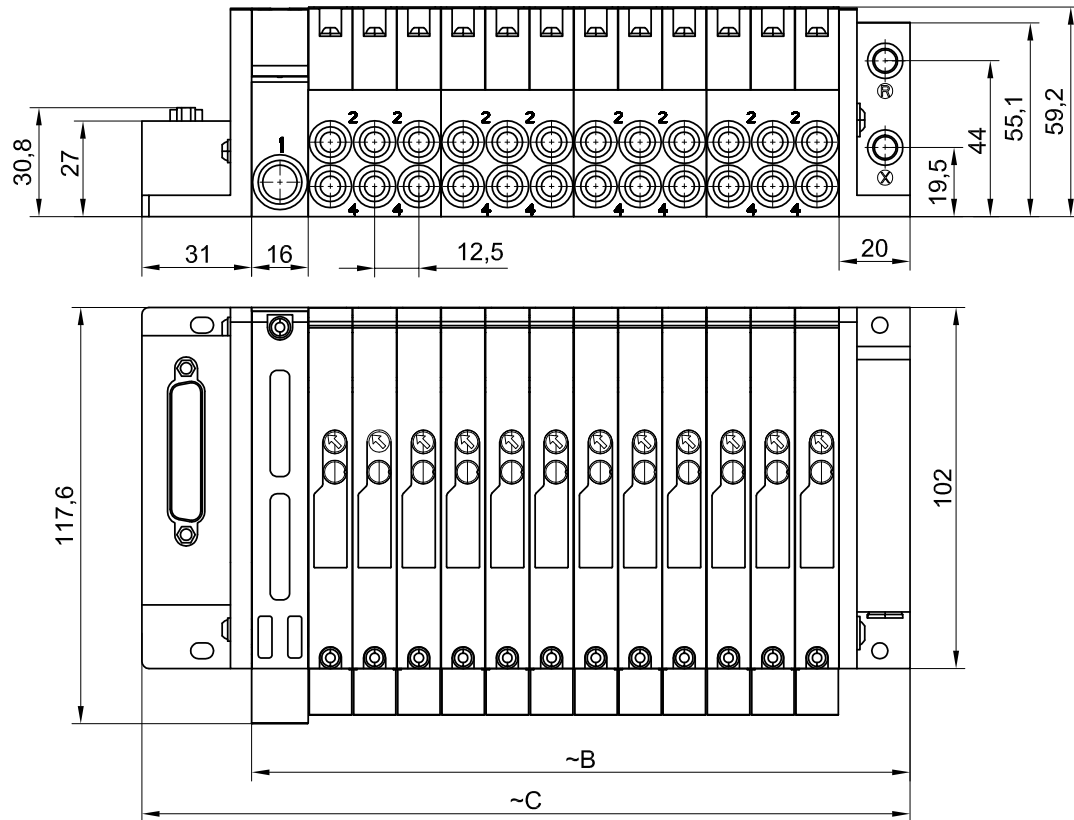

A = number of valve positions x 12.5 mm + number of supply plates x 16 mm + 25.5 mm

B = number of valve positions x 12.5 mm + number of supply plates x 16 mm + 20 mm

C = number of valve positions x 12.5 mm + number of supply plates x 16 mm + 51 mm

When determining the dimensions, consider the supply plate before the first valve.

R = limited preliminary control air outlet, plug connection Ø6 mm. Direction of connection: straight

X = external preliminary control, plug connection Ø6 mm. Direction of connection: straight

## AVAILABLE DIAMETERS FOR PLUG CONNECTIONS

Connector	Available diameters	Direction of connection
1	Ø12 mm	straight
2 and 4	Ø6 mm and Ø8 mm	straight and 90° angle (interchangeable connectors)
3 and 5	Ø12 mm	straight

# VALVE TERMINALS

with multipol (D-SUB) connection



## TECHNICAL PARAMETERS OF VALVES AND TERMINALS

<b>Valve design:</b>	Solenoid valves
<b>Terminal material:</b>	Plastic, aluminium alloy
<b>Fastening:</b>	Ø6 through openings on the plate blocks
<b>Pneumatic connections:</b>	Plug connection
<b>Allowable operating voltage:</b>	24V DC ±10%
<b>Nominal valve flow rate:</b>	for AV03 - 300 l/min; for AV05 - 700 l/min
<b>Installation of valves on the terminal:</b>	in pairs – 2 valves per block, an unused valve space can be plugged with a plate, obtaining an odd number of distributors

## FUNCTIONS OF VALVES INSTALLED ON THE TERMINAL

Valve function	Valve letter code	Order number AV05	Order number AV03	Graphic diagram
2x2/2	K	22. R422103315	22.R422102436	
2x3/2	I	22. R422103008	22. R422102432	
	J	22. R422103006	22. R422102430	
	G	22. R422103010	22. R422102434	
5/2	A	22. R422103004	22. R422102428	
	B	22. R422103002	22. R422102426	
	C	22. R422103012	22. R422102503	
5/3	D	22. R422103000	22. R422102424	
endcap	-	22. R422102526	22. R422102462	



# VALVE TERMINALS

with multipol (D-SUB) connection

## ORDERING PROCEDURE

The configuration of the valve terminals is performed by qualified staff.  
To order a terminal, send an enquiry to the e-mail or telephone number:

**e-mail: [prema@prema.pl](mailto:prema@prema.pl)**

**tel.: +48 41 361 95 24**

In your order, please specify: the name of the terminal, the number and letter code of the valves,  
the diameters of the plug connections, e.g:

**Valve terminal AV03, 6 J valves (2x3/2), connection 1- Ø4 mm, connection 2 and 4 -Ø3 mm**



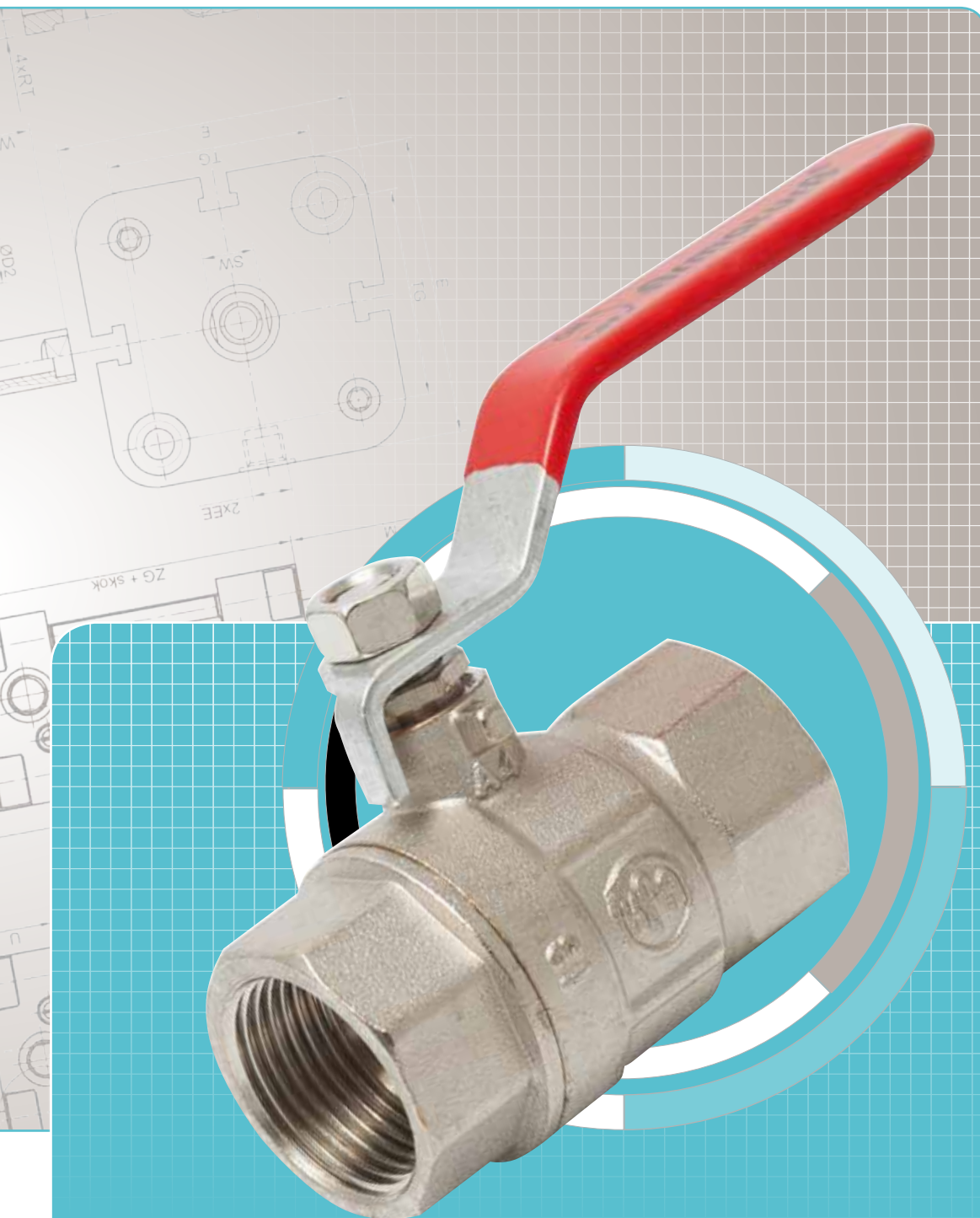

# FLOW, CUT-OFF AND LOGIC VALVES



## Flow, cut-off and logic valves

- 6.01.** Cut-off valves
- 6.02.** Ball cut-off valves
- 6.03.** Throttle valves
- 6.04.** Throttle-check valves
- 6.05.** Check valves
- 6.06.** Quick exhaust valves
- 6.07.** Logic valves
- 6.08.** Safety valves



## TECHNICAL SPECIFICATIONS

<b>Maximum operating pressure:</b>	10 bar	
<b>Operating temperature range:</b>	from 0°C to +60°C	
<b>Operation position</b>	any position	
<b>Supply method:</b>	Hoses with compressed air with a maximum particle size of 40 µm, lubricated with oil mist 2 – 5 drops/m <sup>3</sup>	
<b>Materials:</b>		
<b>Body, cover</b> - aluminium alloy <b>Tube, knob</b> - plastic <b>Needle</b> - carbon steel with zinc-plated external surface <b>Seals</b> - nitrile-butadiene rubber		



## DIMENSIONS

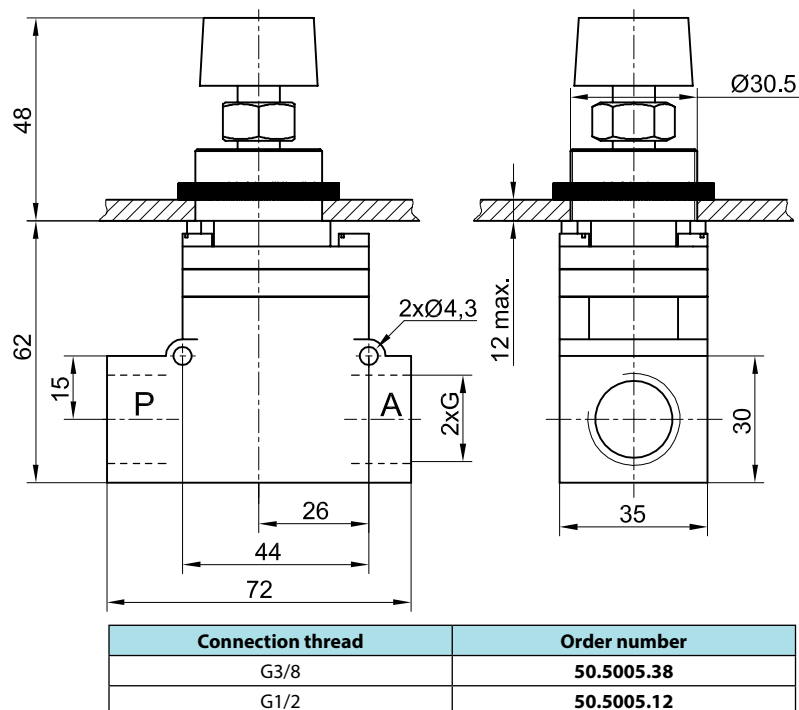

## ORDERING PROCEDURE

In your order, please specify: name, connection thread, order number and the number of pieces, e.g.:

**Cut-off valve G1/2 no. 50.5005.12 1 pc.**



## TECHNICAL SPECIFICATIONS

<b>Maximum operating pressure:</b>	10 bar
<b>Medium:</b>	compressed air or other non-aggressive gas, non-aggressive liquids
<b>Operating temperature range:</b>	0 to +80°C
<b>Materials:</b>	
<b>Body</b>	- nickel-plated brass
<b>Clamping ring</b>	- brass
<b>Nut</b>	- nickel-plated brass
<b>Ball sealing</b>	- PTFE
<b>Sealing ring</b>	- NBR 70
<b>Joint</b>	- brass
<b>Handle</b>	- polyamide
<b>Handle insert</b>	- polyamide
<b>Screw</b>	- steel
<b>Ball</b>	- chrome-plated brass
<b>Sealing ring</b>	- NBR 70

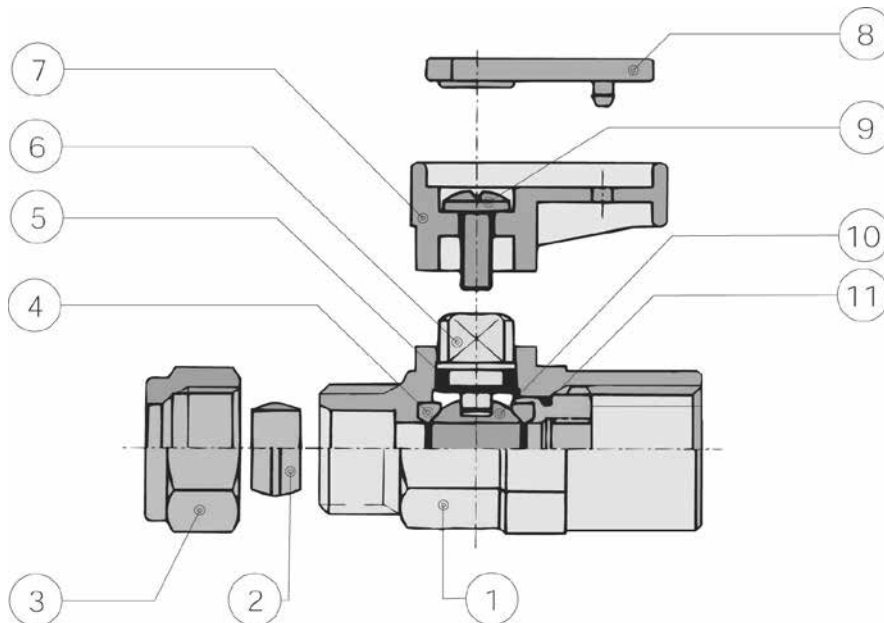

1) Body, 2) Clamping ring, 3) Nut, 4) Ball sealing, 5) Seal. ring, 6) Connector, 7) Handle, 8) Handle insert, 9) Screw, 10) Ball, 11) Seal. ring

Cut-off valves are used to manually close the flow of the working medium in industrial systems. The advantage of these valves are small overall dimensions and the possibility of direct mounting on pipes made of copper, polyamide, nylon, etc. (in the version with a connector).

## - WITH FEMALE THREAD G1/8 TO G3/4

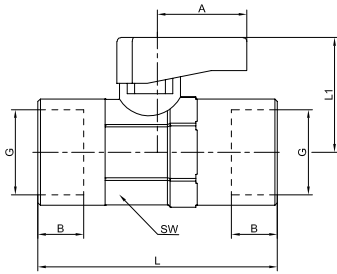

Connection thread G	DIMENSIONS					Order number
	A	B	L	L1	SW	
G 1/8	19	7	35	21	14-15	80.6400.18W
G 1/4	19	8	37	21	14-15	80.6400.14W
G 3/8	19	9	42	22	18-19	80.6400.38W
G 1/2	26	10	49	30.5	22-23	80.6400.12W
G 3/4	26	12	58	33	28-30	80.6400.34W

## - WITH FEMALE AND MALE THREAD G1/8 TO G3/4

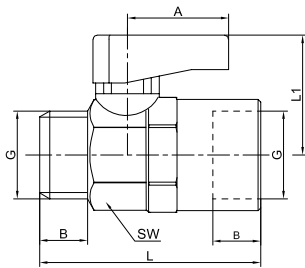

Connection thread G	DIMENSIONS					Order number
	A	B	L	L1	SW	
G 1/8	19	7	34	21	14-15	80.6410.18WZ
G 1/4	19	8	35	21	14-15	80.6410.14WZ
G 3/8	19	9	39	22	18-19	80.6410.38WZ
G 1/2	26	10	45	30.5	22-23	80.6410.12WZ
G 3/4	26	12	52	33	28-30	80.6410.34WZ

## - WITH MALE THREAD G1/8 TO G3/8

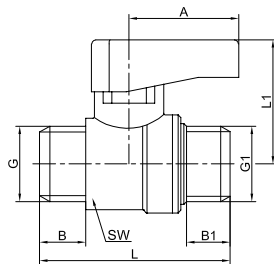

Connection thread		DIMENSIONS						Order number
G	G1	A	B	B1	L	L1	SW	
G 1/8	1/8	19	7	7	32	21	14-15	80.6420.1818Z
G 1/8	1/4	19	7	8	32	21	14-15	80.6420.1814Z
G 1/4	1/4	19	8	8	33	21	14-15	80.6420.1414Z
G 3/8	1/4	19	9	8	33	21	14-15	80.6420.3814Z
G 3/8	3/8	19	9	9	37	22	18-19	80.6420.3838Z

## - WITH THREAD G1/8 TO G3/8 WITH VENT

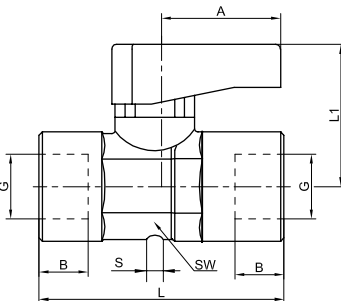

Connection thread G	DIMENSIONS						Order number
	A	B	L	L1	SW	S	
G 1/8	19	7.4	36	21	14-15	1.5	80.6600.1818
G 1/4	19	11	43	21	14-15	1.5	80.6600.1414
G 3/8	19	11.4	47	22	18-19	2	80.6600.3838

Connection thread G	DIMENSIONS						Order number
	Dz	A	B	L	L1	SW	
G 1/8	8	19	7	43	21	14-15	80.6430.1808
G 1/4	8	19	8	43	21	14-15	80.6430.1408
G 3/8	10	19	9	48	22	14-15	80.6430.3810
G 1/2	12	19	9	49	22	18-19	80.6430.1212
G 1/2	14	26	10	55.5	30.5	22-23	80.6430.1214

## - WITH CONNECTOR FOR COPPER PIPES AND FEMALE THREAD G1/8 TO G1/2

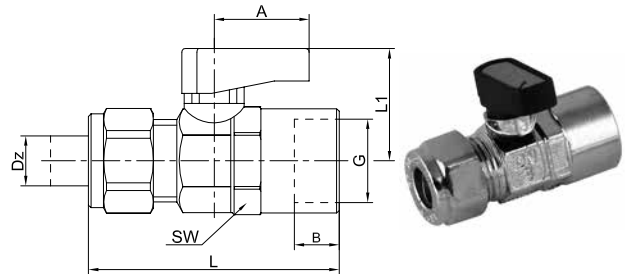

DIMENSIONS					Order number
Dz	A	L	L1	SW	
6	19	46	21	14-15	80.6450.0606
8	19	48	21	14-15	80.6450.0808
10	19	51	22	18-19	80.6450.1010

## - WITH CONNECTORS FOR COPPER PIPES

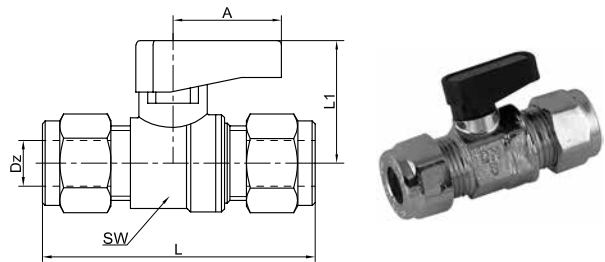

DIMENSIONS					Order number
D	A	L	L1	SW	
4	19	44	21	14-15	80.6560.0404
6	19	48	21	14-15	80.6560.0606
8	19	48	22	14-15	80.6560.0808

## - WITH PUSH-IN FITTINGS

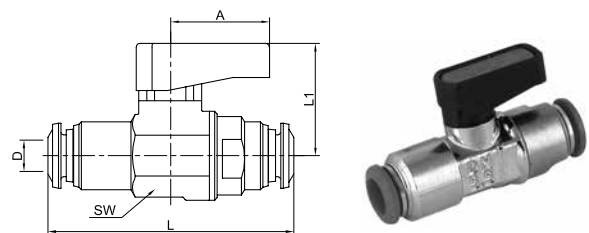

DIMENSIONS						Order number
Dz	L	L1	L2	P	SW	
8	50	21	32	30	14-15	80.6500.0808

## - WITH CONNECTORS FOR COPPER PIPES WITH HANDLE

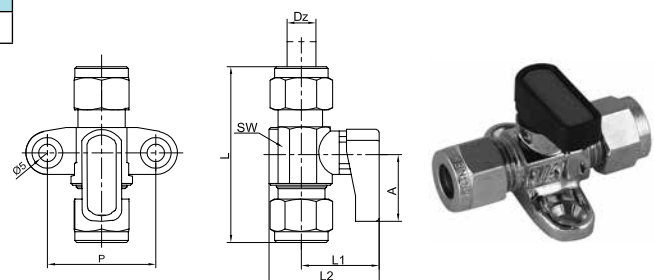

## - TYPE L

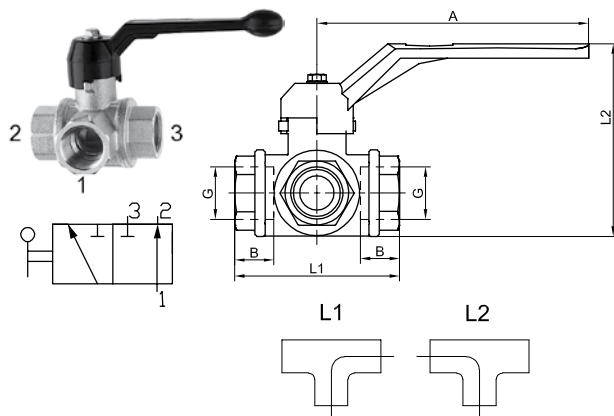

DIMENSIONS					Order number
G	A	B	L1	L2	
1/4	125	12	77	85	80.1081.A14
3/8	125	15	77	85	80.1081.B14
1/2	125	15	77	85	80.1081.C14
3/4	145	18	92	107	80.1081.D14
1	170	22	104	124	80.1081.E14

## - TYPE T

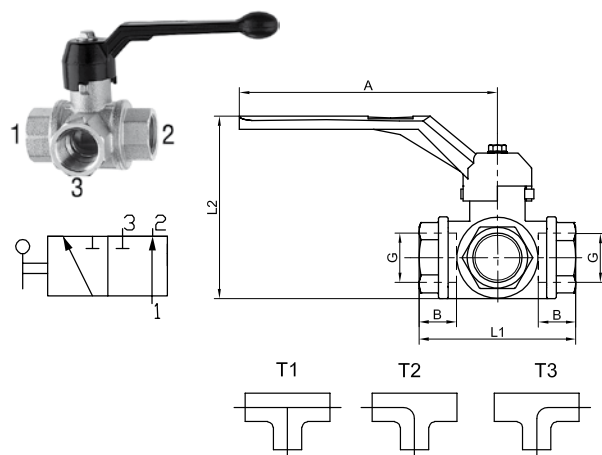

DIMENSIONS					Order number
G	A	B	L1	L2	
1/4	125	12	77	85	80.1084.A14
3/8	125	15	77	85	80.1084.B14
1/2	125	15	77	85	80.1084.C14
3/4	145	18	92	107	80.1084.D14
1	170	22	104	124	80.1084.E14

## - WITH FEMALE THREAD ISO 228

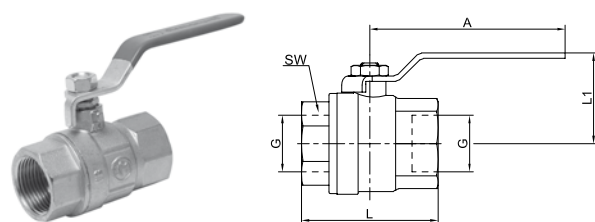

DIMENSIONS					Order number
G	A	L	L1	SW	
1/2	75	46	47.5	25	80.6067.12W
3/4	75	56.5	51	31	80.6067.34W
1	110	65.5	63	38	80.6067.10W
1 1/4	110	77	68.5	48	80.6067.1014W
1 1/2	140	88.5	84.5	54	80.6067.1012W
2	140	101.5	92.5	67	80.6067.20W

## - WITH MALE AND FEMALE THREAD AND EXTERNAL ISO 228

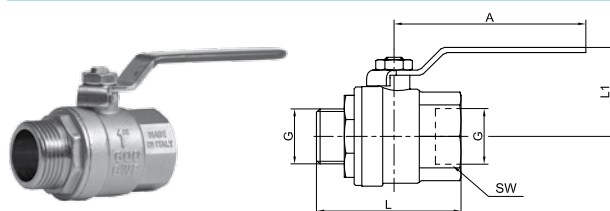

DIMENSIONS					Order number
G	A	L	L1	SW	
1/2	75	56	47.5	25	80.6069.12WZ
3/4	75	63.5	51	31	80.6069.34WZ
1	110	74	63	38	80.6069.10WZ
1 1/4	110	85	68.5	48	80.6069.1014WZ
1 1/2	140	100	84.5	54	80.6069.1012WZ
2	140	121.5	92.5	67	80.6069.20WZ

DIMENSIONS									Order number
G	A	L	L1	L2	P	Smax	SW1	SW2	
1/8-1/8-1/8	19	35	33.5	15.5	14.5	4.5	17	17	80.6700.181818
1/4-1/4-1/4	19	37	33.5	17.5	14.5	4.5	17	17	80.6700.141414
3/8-3/8-3/8	19	42	35	19.5	14.5	4.5	17	21	80.6700.383838

## - TYPE L

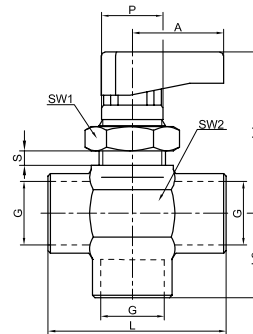

DIMENSIONS									Order number
G	A	L	L1	L2	P	Smax	SW1	SW2	
1/8-1/8-1/8	19	35	33.5	15.5	14.5	4.5	17	17	80.6710.181818
1/4-1/4-1/4	19	37	33.5	17.5	14.5	4.5	17	17	80.6710.141414
3/8-3/8-3/8	19	42	35	19.5	14.5	4.5	17	21	80.6710.383838

## - TYP T

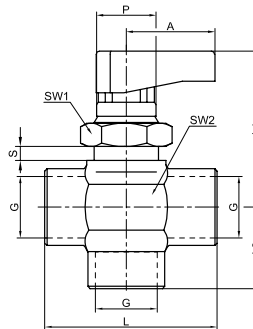

DIMENSIONS									Order number
G	A	L	L1	L2	P	Smax	SW1	SW2	
1/8-1/8-1/8	19	28.5	33.5	15.5	14.5	4.5	17	17	80.6720.181818
1/4-1/4-1/4	19	28.5	33.5	17.5	14.5	4.5	17	17	80.6720.141414
3/8-3/8-3/8	19	42	35	19.5	14.5	4.5	17	21	80.6720.383838

## - TYPE L

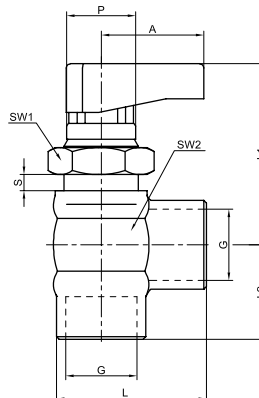

## ORDERING PROCEDURE

In your order, please specify: name, connection thread, order number and the number of pieces, e.g.:

**Ball cut-off valve with female thread G 1/4 No. 80.6400.14W 1 pc.**



## TECHNICAL SPECIFICATIONS

<b>Maximum operating pressure:</b> 10 bar
<b>Materials:</b>
<b>Body</b> - brass OT58 nickel-plated
<b>Ball</b> - brass OT58 nickel-plated
<b>Seals</b> - Teflon (working temperature from 0 to + 60°C)
<b>Handle</b> - cast aluminium, black

## DIMENSIONS

### Ball cut-off valve with vent

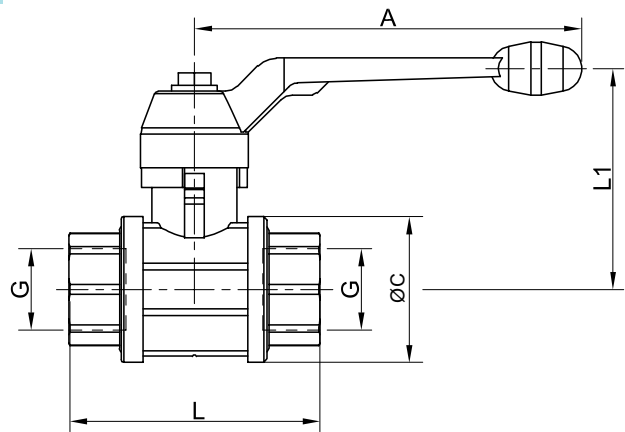
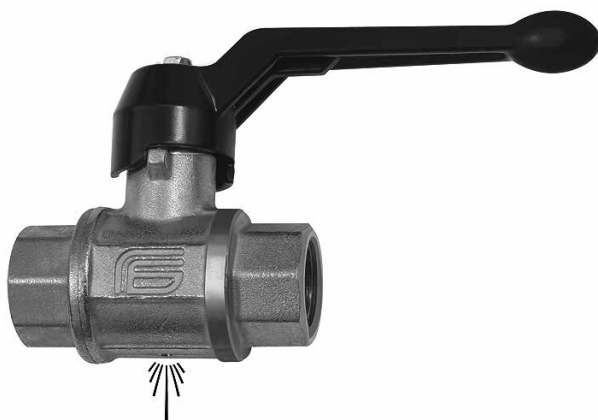

Dimension [mm]					Order number
G	A	C	L	L1	
Rp 1/4	100	29	52	61	80.0350.0014
Rp 3/8	100	29	55	61	80.0350.0038
Rp 1/2	100	36	69	64	80.0350.0012
Rp 3/4	120	45	77	76	80.0350.0034
Rp 1	120	54	89	80	80.0350.0100
Rp 1 1/4	150	65	103	98	80.0350.0114
Rp 1 1/2	150	79	114	104	80.0350.0112
Rp 2	175	96	134	119	80.0350.0200

### Ball cut-off valve with vent

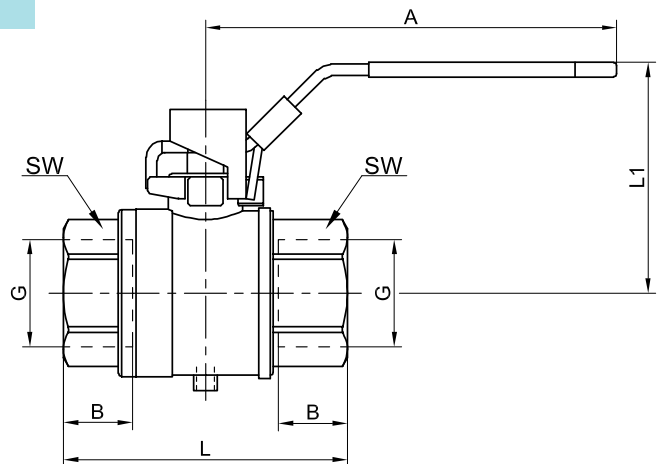

Dimension [mm]						Order number
G	A	B	L	L1	SW	
Rp 1/4	96	12	45	48.5	20	80.0321.0014
Rp 3/8	96	12	45	48.5	20	80.0321.0038
Rp 1/2	96	15.5	59	51	25	80.0321.0012
Rp 3/4	117	17	64	60	31	80.0321.0034
Rp 1	117	21	81	64	40	80.0321.0100
Rp 1 1/4	157	23	93	80	49	80.0321.0114
Rp 1 1/2	157	23	102	86	54	80.0321.0112
Rp 2	157	26.5	121	93	68.5	80.0321.0200

## TECHNICAL SPECIFICATIONS

<b>Maximum operating pressure:</b> 500 bar
<b>Operating temperature:</b> from -10°C to +100°C
<b>Materials:</b> Body, ball, handle - steel

## DIMENSIONS

### CUT-OFF VALVES FOR HIGH PRESSURE

#### Ball cut-off valve

Connection thread	Order number
G 1/4	80.0799.0014
G3/8	80.0799.0038
G1/2	80.0799.0012
G 3/4	80.0799.0034
G 1	80.0799.0100
G 1 1/4	80.0799.0114
G 1 1/2	80.0799.0112
G 2	80.0799.0200

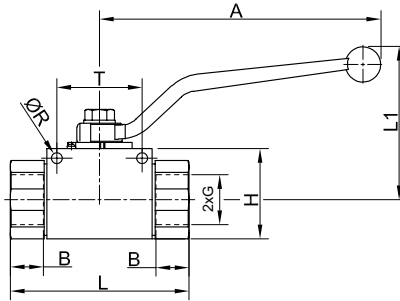

#### 3-way valve type L

Connection thread	Order number
G 1/4	80.0721.0014
G3/8	80.0721.0038
G1/2	80.0721.0012
G 3/4	80.0721.0034
G 1	80.0721.0100

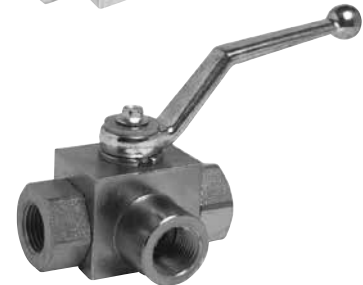
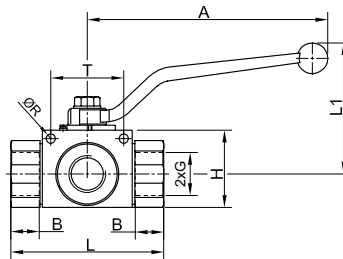

Dimension [mm]									
G	A	B	H	L	L1	Pressure [bar]	ØR	T	
G 1/4	110	15.5	35	71	91.5	500*/400	5.25	34	
G3/8	110	15.5	40	73	96.5	500*/400	5.25	34	
G1/2	110	17	43	83	99.5	500*/350	5.25	36	
G 3/4	180	21	55	95	106.5	315*/350	6.25	50	
G 1	180	24	65	112	116.5	315*/350	6.25	50	
G1 1/4*	180	24	65	120	116.5	315*	6.25	50	
G 1 1/2*	300	23	107	131	134.5	315*	-	-	
G 2*	300	21	114	140	141.5	315*	-	-	

\* Only applies to 2-way valve (80.0799)

#### Ball cut-off valve with a safety device

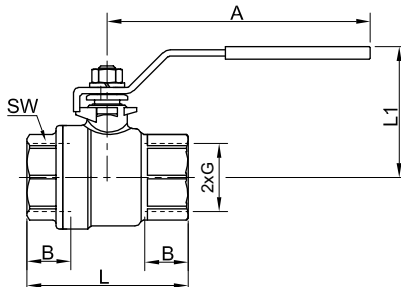

Dimension [mm]							Order number
G	A	B	L	L1	SW		
G 1/4	100	10.5	46.8	53	17	80.0715.0014	
G3/8	100	10.5	48.5	53	20.8	80.0715.0038	
G1/2	100	13	58	57	25.5	80.0715.0012	
G 3/4	127	13.2	65.7	66	31	80.0715.0034	
G 1	127	15.2	77	70	38.5	80.0715.0100	
G 1 1/4	154	18	90	85	48	80.0715.0114	
G 1 1/2	154	18.3	98	89	54	80.0715.0112	
G 2	192	22.5	121	140	67	80.0715.0200	
G 2 1/2	244	25.5	145	142	83.5	80.0715.0212	
G 3	244	28.4	166	151	98	80.0715.0300	
G 4	330	36	214	176	128	80.0715.0400	

## TECHNICAL SPECIFICATIONS

<b>Maximum operating pressure:</b> 10 bar
<b>Operating temperature range:</b> from -30°C to +160°C
<b>Materials:</b>
<b>Body</b> - brass OT58 nickel-plated
<b>Ball</b> - brass coated with nickel-chromium plating
<b>Seals</b> - Teflon
<b>Handle</b> - steel coated with red epoxy enamel

### - WITH FEMALE THREAD G3/8 TO G3/4

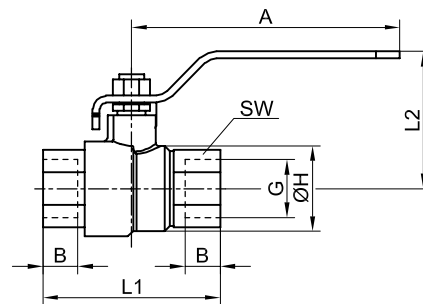

Connection thread G	DIMENSIONS						Order number
	A	B	H	L1	L2	SW	
G3/8	83	11.4	23	51.5	47	20	50.5006.383W
G1/2	95	13.5	33	55	51	25	50.5006.123W
G3/4	110	12.5	39	57	60	31	50.5006.343W

### - WITH MALE AND FEMALE THREAD 3/8 TO G3/4

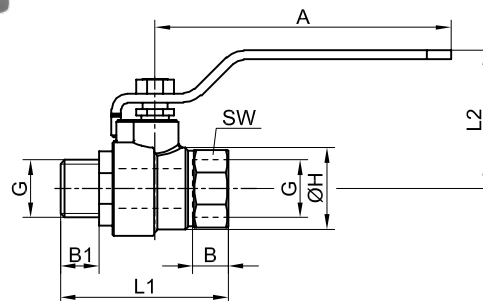

Connection thread G	DIMENSIONS							Order number
	A	B	B1	H	L1	L2	SW	
G3/8	83	11.4	13	23	59.5	47	20	50.5006.383Z
G1/2	95	13.5	15	33	67	51	25	50.5006.123Z
G3/4	110	12.5	16.5	39	73.5	60	31	50.5006.343Z

## TECHNICAL SPECIFICATIONS

<b>Temperature range:</b> -10°C - 110°C
<b>Max. operating pressure</b> 138/250 bar
<b>Materials:</b>
<b>Body</b> - cast iron
<b>Seals</b> - EPDM
<b>Flap</b> - nickel-plated



Connection threads	Order numbers							
	Welded connection				Threaded connection			
	butterfly valve		ball valve		butterfly valve		ball valve	
	138 bar	250 bar	138 bar	250 bar	138 bar	250 bar	138 bar	250 bar
<b>G1/2</b>	85.0119.012	85.0121.012	85.0419.012	85.0421.012	85.0118.012	85.0120.012	85.0418.012	85.0420.012
<b>G3/4</b>	85.0119.034	85.0121.034	85.0419.034	85.0421.034	85.0118.034	85.0120.034	85.0418.034	85.0420.034
<b>G1/2</b>	85.0119.012	85.0121.012	85.0419.012	85.0421.012	85.0118.012	85.0120.012	85.0418.012	85.0420.012
<b>G1/ 1/2</b>	85.0119.112	85.0121.112	85.0419.112	85.0421.112	85.0118.112	85.0120.112	85.0418.112	85.0420.112
<b>G2</b>	85.0119.200	85.0121.200	85.0419.200	85.0421.200	85.0118.200	85.0120.200	85.0418.200	85.0420.200

## ORDERING PROCEDURE

In your order, please specify: name, connection thread, order number and number of pieces, e.g.:

**Cut-off valve with welded connection, G 1/2, no. 85.0119.012 1 pc.**



## TECHNICAL SPECIFICATIONS

<b>Maximum operating pressure:</b>	10 bar	
<b>Operating temperature range:</b>	from 0°C to +60°C	
<b>Minimum opening pressure of the check valve</b>	1.5 bar	
<b>Operation position</b>	any position	
<b>Supply method:</b>	Hoses with compressed air with a maximum particle size of 40 µm, lubricated with oil mist 2 – 5 drops/m <sup>3</sup>	
<b>Materials:</b>		
<b>Body, cover</b> - aluminium or zinc alloy <b>Tube, knob</b> - plastic <b>Needle</b> - carbon steel or brass with galvanised surface <b>Seals</b> - nitrile-butadiene rubber		



## HOSE THROTTLE VALVE

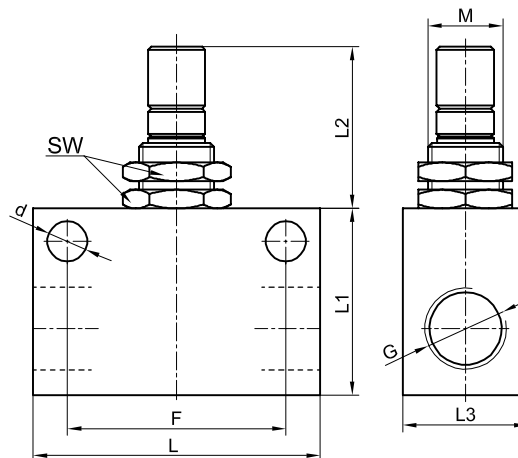

Connection thread G	DIMENSIONS								Order number
	d	F	L	L1	L2	L3	M	SW	
<b>M5</b>	ø4.5	18	26	16	34-39	12	M10x0.75	12	<b>80.5094.M5</b>
<b>G1/8</b>	ø4.5	24.7	35	22	48-56	20	M12x0.75	15	<b>80.5094.18</b>
<b>G1/4</b>	ø6.5	35	46	30	56-64	20	M12x0.75	15	<b>80.5094.14</b>
<b>G3/8</b>	ø6.5	35	50	30	68-73	25	M18x1	22	<b>80.5094.38</b>
<b>G1/2</b>	ø6.5	44	60	40	76-83	25	M18x1	22	<b>80.5094.12</b>

## ORDERING PROCEDURE

In your order, please specify: name, connection thread, order number and number of pieces, e.g.:

**Hose throttle valve G3/8 no. 80.5094.38 1 pc.**



## TECHNICAL SPECIFICATIONS

<b>Maximum operating pressure:</b>	10 bar
<b>Operating temperature range:</b>	from 0°C to +60°C
<b>Minimum opening pressure of the check valve</b>	0.15 bar
<b>Operation position</b>	any position
<b>Supply method:</b>	Hoses with compressed air with a maximum particle size of 40 µm, lubricated with oil mist 2 – 5 drops/m <sup>3</sup>
<b>Materials:</b>	
<b>Body, cover</b>	- aluminium or zinc alloy
<b>Tube, knob</b>	- plastic
<b>Needle</b>	- carbon steel or brass with galvanised surface
<b>Seals</b>	- nitrile-butadiene rubber

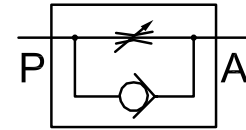

## THROTTLE-CHECK VALVE M5

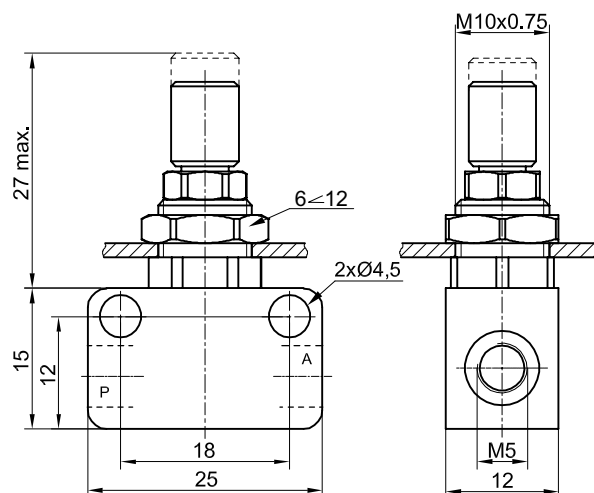

Connection thread G	Order number
M5	50.5001.RFUM5



## THROTTLE-CHECK VALVE G1/8 - G1/4

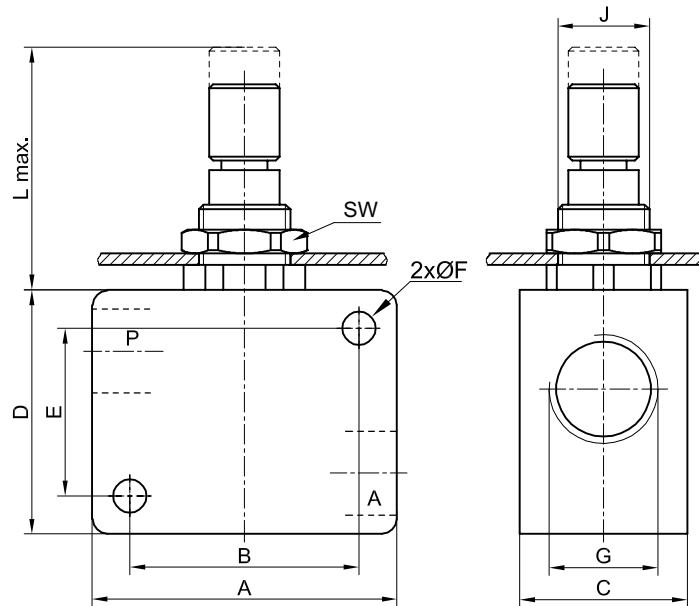

Connection thread G	DIMENSIONS									Order number
	A	B	C	D	E	F	J	L	SW	
G1/8	32	23	16.8	22	13	ø4.5	M12x0.75	35	15	50.5001.RFU18
G1/4	40	30	22	32	22					50.5001.RFU14

## THROTTLE-CHECK VALVE G3/8 - G1/2

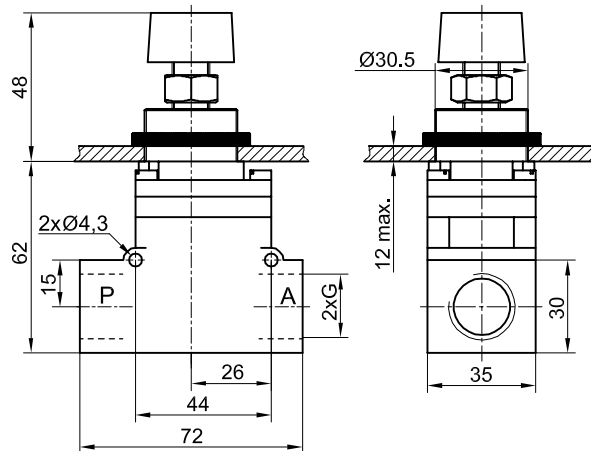

Connection thread G	Order number
G3/8	50.5001.38
G1/2	50.5001.12

## HOSE THROTTLE-CHECK VALVE WITH THREAD M5 TO G1/2

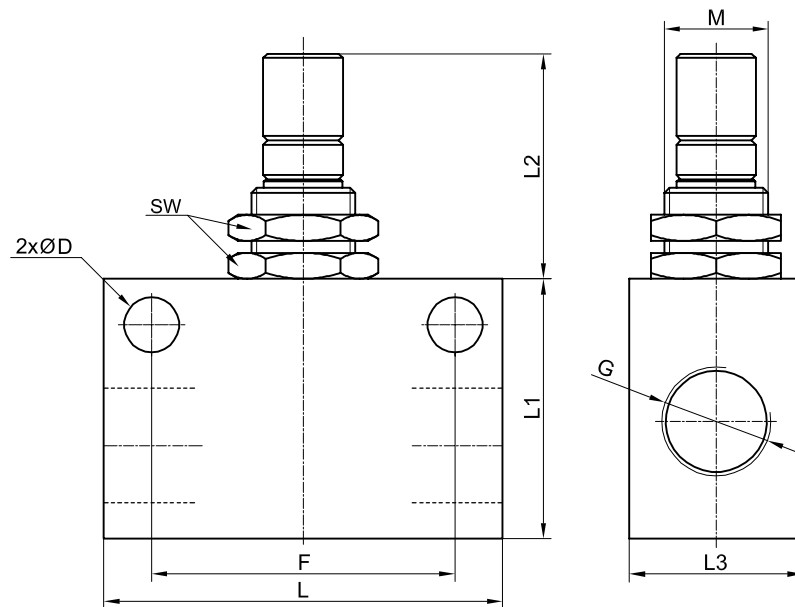

Connection thread G	DIMENSIONS								Order number
	L	L1	L2	L3	ØD	F	M	SW	
<b>M5</b>	26	16	34-39	12	ø4.5	18	M10x0.75	12	80.5093.M5
<b>G1/8</b>	35	22	48-56	20	ø4.5	24.7	M12x0.75	15	80.5093.18
<b>G1/4</b>	46	30	56-64	20	ø6.5	35	M12x0.75	15	80.5093.14
<b>G3/8</b>	50	30	68-73	25	ø6.5	35	M18x1	22	80.5093.38
<b>G1/2</b>	60	40	76-83	25	ø6.5	44	M18x1	22	80.5093.12

## ORDERING PROCEDURE

In your order, please specify: name, connection thread, order number and number of pieces, e.g.:

**Throttle-check valve G3/8 no. 50.5001.38 1 pc.**



## TECHNICAL SPECIFICATIONS

<b>Maximum operating pressure:</b>	10 bar	
<b>Operating temperature range:</b>	from 0°C to +60°C	
<b>Operation position:</b>	any position	
<b>Supply method:</b>	Hoses with compressed air with a maximum particle size of 40 µm, lubricated with oil mist 2 – 5 drops/m <sup>3</sup>	
<b>Materials:</b>		
<b>Body, nut</b>	- aluminium alloy	
<b>Seals</b>	- nitrile-butadiene rubber	



## DIMENSIONS

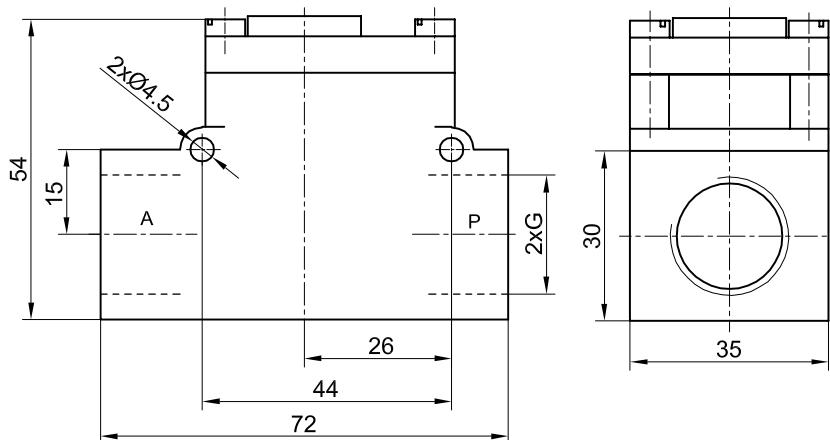

Connection thread G	Order number
G3/8	50.5002.38
G1/2	50.5002.12

## ORDERING PROCEDURE

In your order, please specify: name, connection thread, order number and number of pieces, e.g.:

**Check valve G3/8 no. 50.5002.38 1 pc.**



## TECHNICAL SPECIFICATIONS

<b>Maximum operating pressure:</b>	10 bar	
<b>Operating temperature range:</b>	from 0°C to +60°C	
<b>Operation position:</b>	any position	
<b>Supply method:</b>	Hoses with compressed air with a maximum particle size of 40 µm, lubricated with oil mist 2 – 5 drops/m <sup>3</sup>	
<b>Materials:</b>		
<b>Body, nut</b>	- aluminium alloy	
<b>Seals</b>	- nitrile-butadiene rubber	

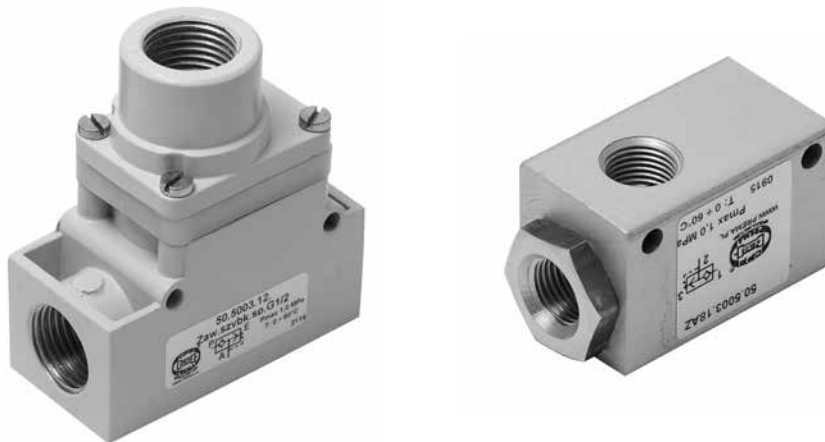

## QUICK EXHAUST VALVE G1/8 TO G1/4

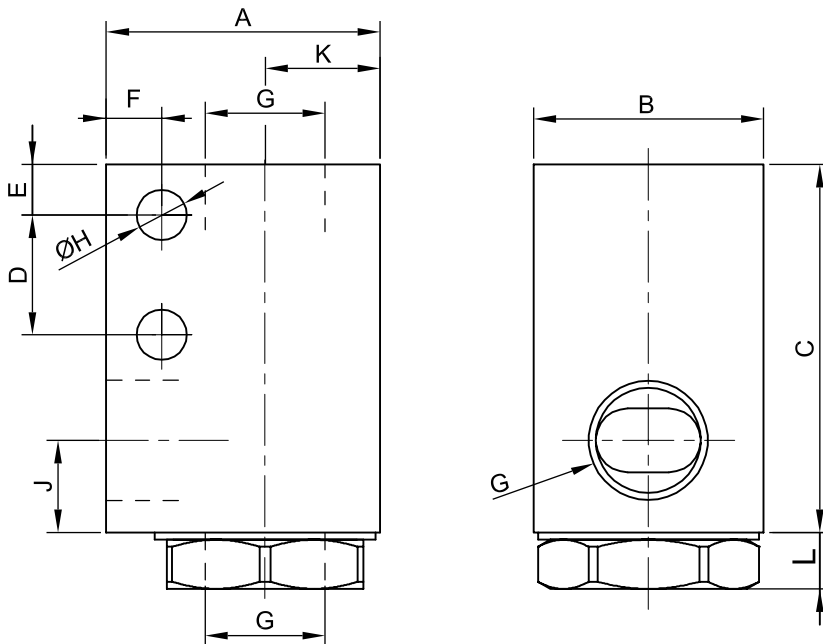

Connection thread	DIMENSIONS										Order number
	A	B	C	D	E	F	ØH	J	K	L	
G1/8	22.5	20	34.5	26.5	4	3	3.5	12.5	9	4	50.5003.18 AZ
G1/4	35	25	40	13	5.5	6	5.5	10	12.5	5	50.5003.14 AZ

## QUICK EXHAUST VALVE G3/8 TO G1/2

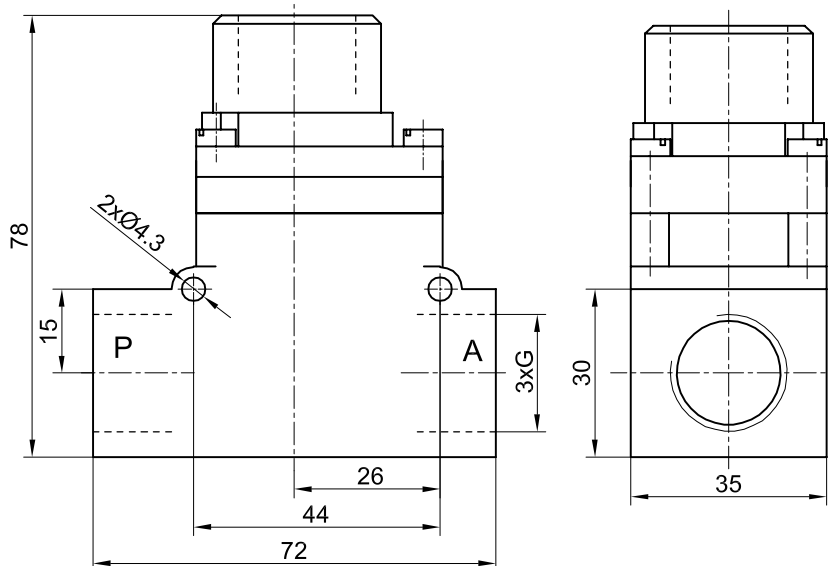

Connection thread	Order number
G3/8	50.5003.38
G1/2	50.5003.12

## QUICK EXHAUST VALVE M5 - G1 - G1

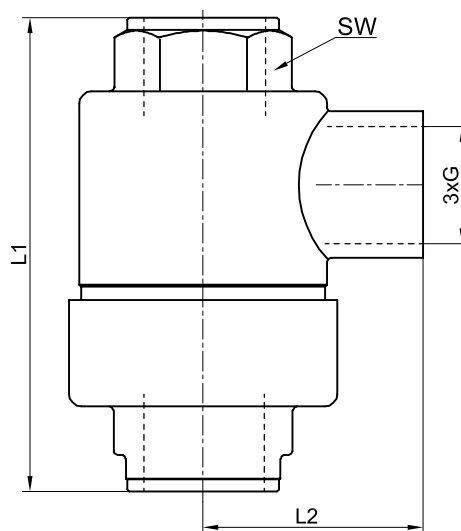

Connection thread	DIMENSIONS			Order number
	L1	L2	SW	
M5	25	10	17	80.5003.M5
G1/8	42	20	15	80.5003.18
G1/4	54	25	19	80.5003.14
G3/8	61	27	22	80.5003.38
G1/2	72	32	26	80.5003.12
G3/4	88	37	32	80.5003.34
G1	109	48	46	80.5003.100

## ORDERING PROCEDURE

In your order, please specify: name, connection thread, order number and the number of pieces, e.g.:

**Quick exhaust valve G1/8 No. 50.5003.18 1 pc.**

## TECHNICAL SPECIFICATIONS

<b>Maximum operating pressure:</b>	10 bar
<b>Operating temperature range:</b>	from 0°C to +60°C
<b>Operation position</b>	any position
<b>Supply method:</b>	Hoses with compressed air with a maximum particle size of 40 µm, lubricated with oil mist 2 – 5 drops/m <sup>3</sup>
<b>Materials:</b>	
<b>Body, nut</b>	- aluminium alloy
<b>Seals</b>	- nitrile-butadiene rubber

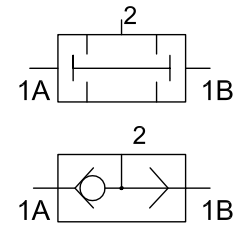

## LOGIC VALVE SUM OR G1/8 TO G1/4

## LOGIC VALVE PRODUCT G1/8

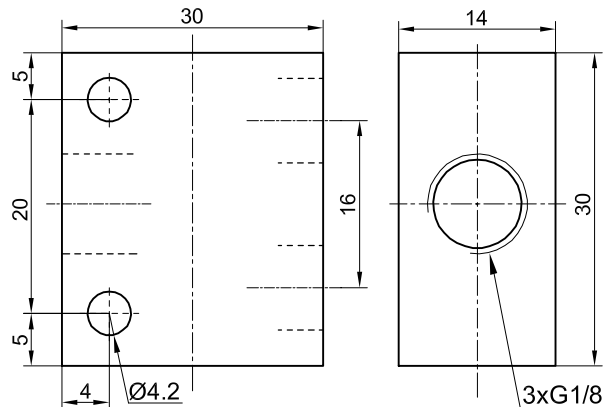
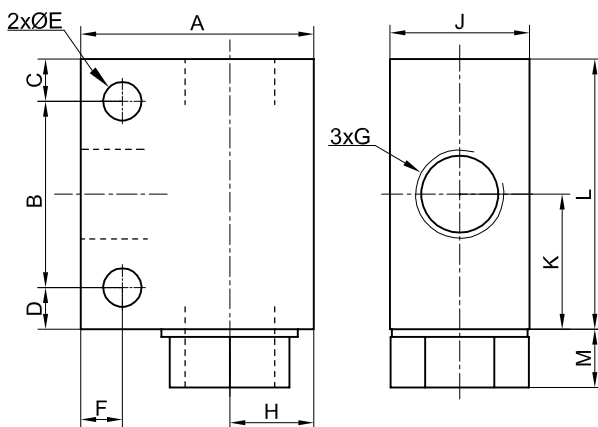

Connection thread	DIMENSIONS											Order number
	A	B	C	D	E	F	ØH	J	K	L	M	
G1/8	25	20	4.5	4.5	4.2	4.5	9	15	14.5	29	5.8	50.5004.18AZ
G1/4	30	33	5	5	4.2	5	10	20	25	43	-	50.5004.14AZ

Connection thread	Order number
G1/8	50.5005.18AZ

## ORDERING PROCEDURE

In your order, please specify: name, connection thread, order number and the number of pieces, e.g.:

**Shuttle valve G1/8 No. 50.5004.18AZ 1 pc.**





## TECHNICAL SPECIFICATIONS

<b>Operating pressure range:</b>	3 — 10 bar
<b>Operating temperature range:</b>	from -20°C to +80°C
<b>Medium:</b>	compressed air, filtered, lubricated or non-lubricated
<b>Flow rate (6 bar):</b>	750 NI/min for G1/8 1420 NI/min for G1/4
<b>Materials:</b>	
<b>Body, swivel cover, base</b>	- nickel-plated brass
<b>Seals</b>	- NBR, PU



## USE

Controlled valves (check valves and cut-off valves) are used in pneumatic systems to control the actuators. They are mounted directly to the actuator connections, which increases their efficiency and responsiveness. They are mainly used as elements protecting against uncontrolled movement of actuating elements in case of e.g. damage to supply hoses, loss of compressed air or electric power supply (solenoid valves). They can also be used as an emergency stop. Their use avoids mechanical damage and minimises the risk of injury to the operator.

The valves are available in two versions: as a controlled check valve and as a controlled cut-off valve. The upper part of the valves, to which the control signal is fed, can be rotated to match the direction of the supply line. The valves can cooperate with valves controlling the speed of pneumatic actuator movement (screw-in throttle-check valves).

### U - CONTROLLED CHECK VALVE

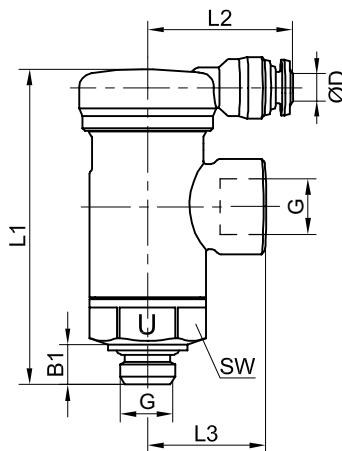

DIMENSIONS							Order number
G	B1	ØD	L1	L2	L3	SW	
1/8	6	4	56	25	18,5	18	80.8880.18
1/4	8	4	58,5	25	20,5	18	80.8880.14

### B - CONTROLLED CUT-OFF VALVE

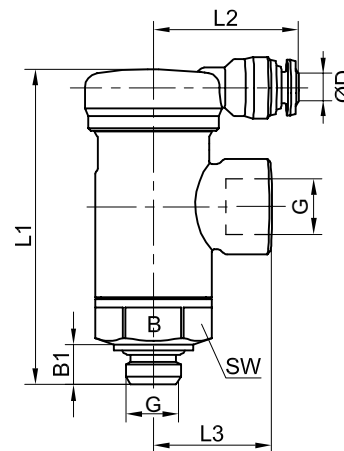

DIMENSIONS							Order number
G	B1	ØD	L1	L2	L3	SW	
1/8	6	4	56	25	18,5	18	80.8890.18
1/4	8	4	58,5	25	20,5	18	80.8890.14

## U - CONTROLLED CHECK VALVE

## B - CONTROLLED CUT-OFF VALVE

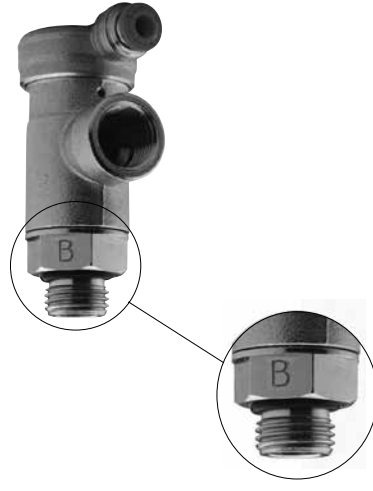
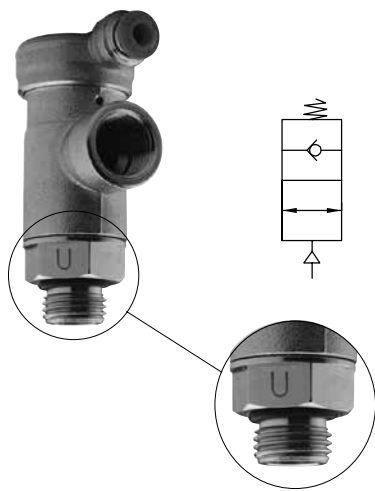

## PRINCIPLE OF OPERATION OF A CONTROLLED CHECK VALVE IN A PNEUMATIC SYSTEM

### ACTUATOR IN MOVEMENT

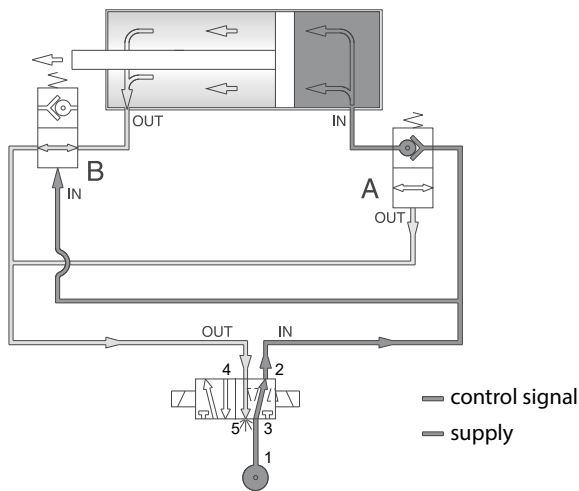

### ACTUATOR STOP

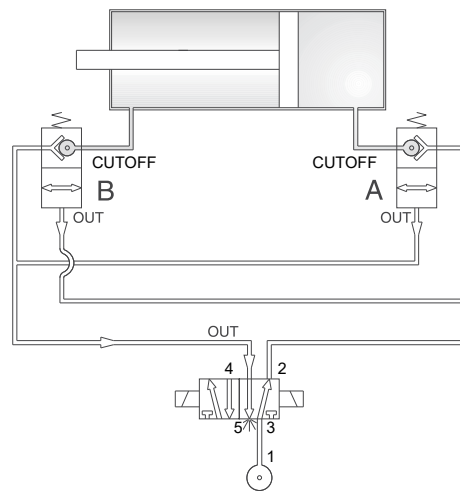

The pneumatic actuator can move in the direction marked with an arrow when a control signal is sent to the controlled check valve B, which opens the valve. This signal is received from the actuator supply conduit (route "2"). The change of direction of actuator movement causes sending a control signal from the second actuator supply line (route "4") to the controlled check valve A and its opening.

The actuator is always stopped if the supply of air to its chambers fails. Controlled check valves A and B cut off the air in the actuator chambers and prevent it from moving. This also occurs in emergency situations, e.g. when the electric power supply to the solenoid of the control valve is interrupted or the supply conduits are mechanically damaged. Valves in systems perform the function of safety valves (so-called pneumatic locks).

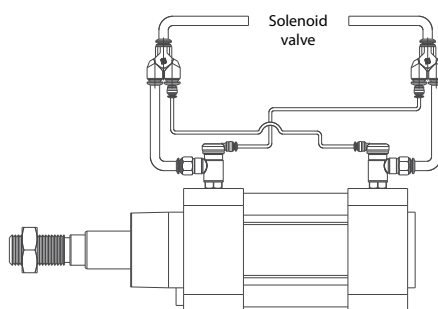

## PRINCIPLE OF OPERATION OF A CONTROLLED CUT-OFF VALVE IN A PNEUMATIC SYSTEM

### ACTUATOR IN MOVEMENT

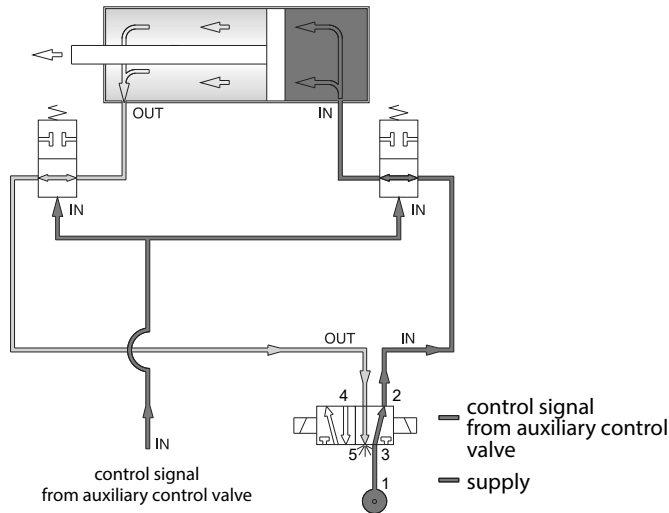

### ACTUATOR STOP

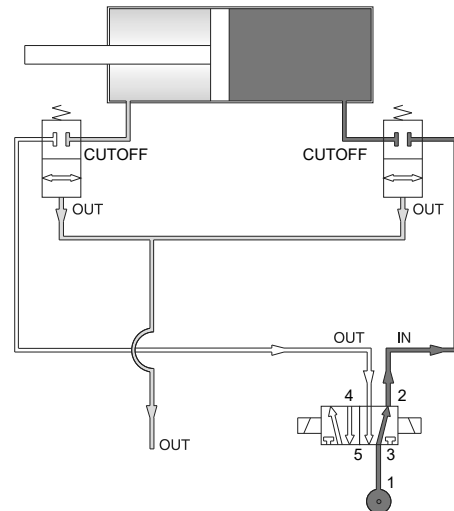

The working and return movement of the pneumatic actuator is only possible with a continuous pneumatic control signal sent to the controlled cut-off valves. This signal can be sent from an independent auxiliary control valve.

The actuator is always stopped if the control signal from an independent control valve or other source fails. Controlled cut-off valves will cut off the working medium in the actuator chambers. Controlled cut-off valves in systems perform a safety function.

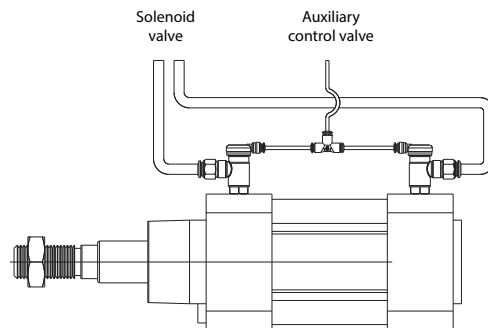

## FLOW CHARACTERISTICS OF VALVES

SIZE G 1/8

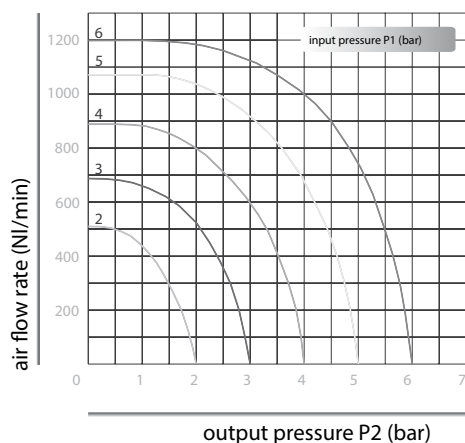

SIZE G 1/4

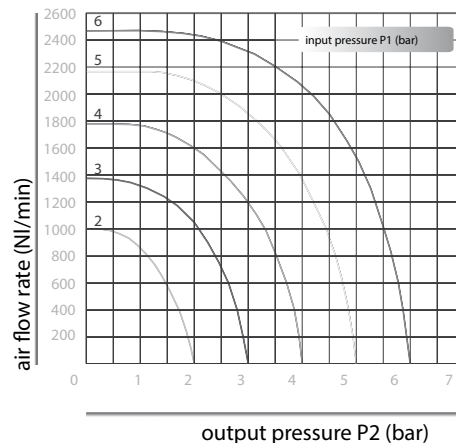

## PRESSURE CHARACTERISTICS OF VALVES

Minimum control pressure of valves as a function of supply pressure in relation to actuator supply pressure.

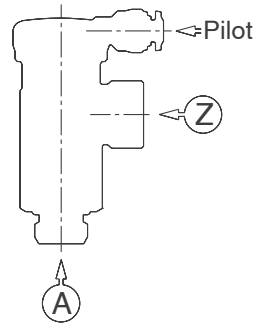

**CONTROLLED CHECK VALVE**

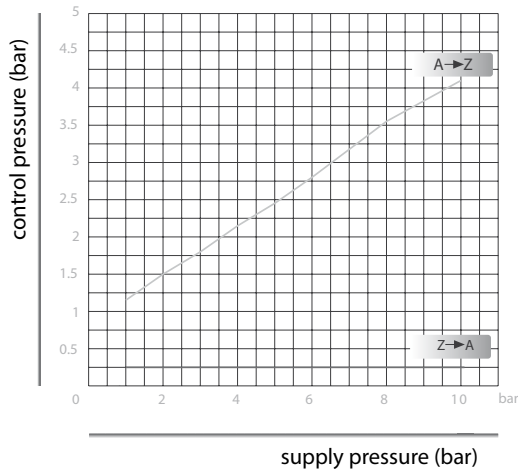

**CONTROLLED CUT-OFF VALVE**

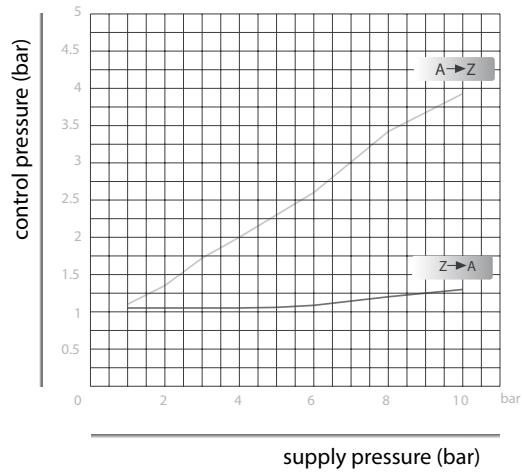

## TECHNICAL SPECIFICATIONS

<b>Maximum operating pressure:</b> as in the table
<b>Operating temperature range:</b> as in the table
<b>Materials:</b>
<b>Body</b> - brass
<b>Mounting</b> - brass
<b>Slot</b> - fluorine rubber (working temp. from -10 to +180°C)



## SAFETY VALVE DN 8

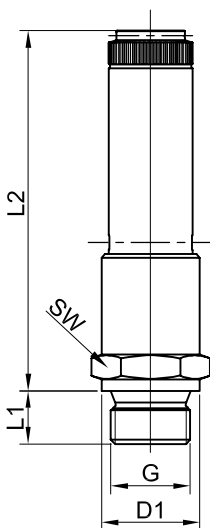

<b>Maximum operating pressure: 50 bar</b>						
<b>Operating temperature range: from -25°C to +180°C</b>						
Dimensions					Pressure range [bar]	Order numbers
G	D1	L1	L2	SW		
G1/4	18	10	63	20	0.3 - 14.2	85.0226.14142
			75	20	14.3 - 40.0	85.0226.14400
			82	20	40.1 - 50.0	85.0226.14500
G3/8	20	12	63	20	0.3 - 14.2	85.0226.38142
			75	20	14.3 - 40.0	85.0226.38400
			82	20	40.1 - 50.0	85.0226.38500
G1/2	24	14	63	24	0.3 - 14.2	85.0227.12142
			75	24	14.3 - 40.0	85.0227.12400
			82	24	40.1 - 50.0	85.0227.12500

## SAFETY VALVE DN 10

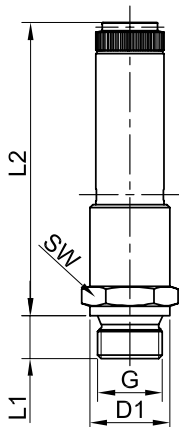

Maximum operating pressure: 50 bar						
Operating temperature range: from -25°C to +180°C						
Dimensions					Pressure range [bar]	Order numbers
G	D1	L1	L2	SW		
G3/8	22	12	75	27	0.3 - 8.51	85.0227.38851
			95	27	8.52 - 40.0	85.0227.38400
			120	27	40.1 - 50.0	85.0227.38500
G1/2	26	14	75	27	0.3 - 8.51	85.0227.12851
			95	27	8.52 - 40.0	85.0227.12400
			120	27	40.1 - 50.0	85.0227.12500
G3/4	32	16	75	32	0.3 - 8.51	85.0227.34851
			95	32	8.52 - 40.0	85.0227.34400
			120	32	40.1 - 50.0	85.0227.34500

## SAFETY VALVE

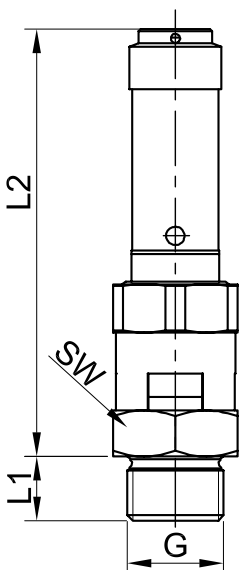

Maximum operating pressure: 25 bar						
Operating temperature range: from -10°C to +200°C						
Dimensions					Pressure range [bar]	Order numbers
G	L1	L2	SW			
G1/2	14	93	27		0.5 - 25	85.0229.12025
G3/4	16	110	32		0.5 - 22	85.0229.34022
G1/2	18	132	41		0.5 - 20	85.0229.12020
G1 1/4	20	152	50		0.5 - 22	85.0229.11422
G1 1/2	22	178	55		0.5 - 16	85.0229.11216
G2	25	203	70		0.5 - 12	85.0229.20012

## ORDERING PROCEDURE

In your order, please specify: name, connection thread, order number and the number of pieces, e.g.:

**Safety valve G1/2 no. 85.0229.12025 1 pc.**





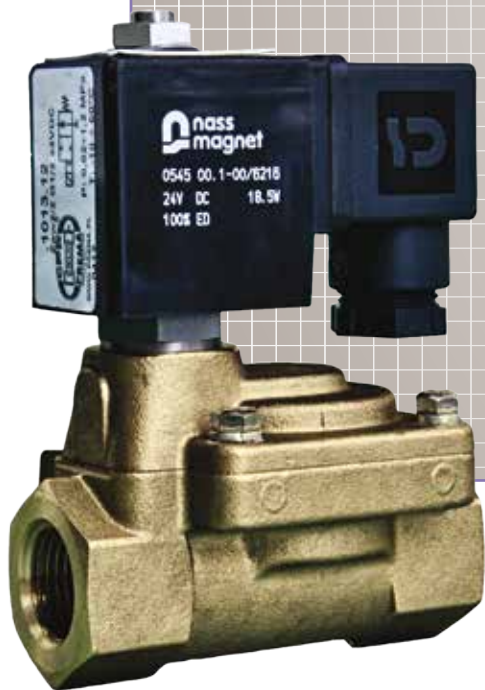



# VALVES FOR VARIOUS WORKING MEDIA

## Valves for different working media

- 7.01.** Two-way solenoid valves
- 7.02.** Three-way solenoid valves
- 7.03.** Modular solenoid valves
- 7.04.** Solenoid valve coils



## TECHNICAL SPECIFICATIONS

<b>Ambient temperature:</b>	-10 to +50°C
<b>Medium:</b>	water, air, non-aggressive media
<b>Control voltage</b>	A - 12V      B - 24V
<b>designation "x" in the order number:</b>	50 Hz alternating current: E - 24V      H - 110V      J - 230V
<b>Materials:</b>	
<b>Body</b>	- brass
<b>Internal parts</b>	- stainless steel
<b>Gasket</b>	- NBR

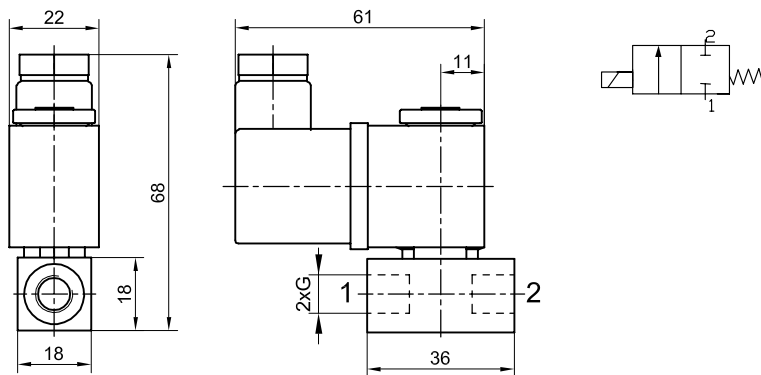

### Electrical protection: IP 65 Power consumption 8.5VA; 6W

Type	Con- nection thread	Nominal diameter [mm]	Operating pressure	Flow rate Kv [m³/h]	Voltage	Max. medium temp. [°C]	Weight [kg]	Order number
2VE1.2M	G1/8	1.2	0-25 bar	0.04	AC	80	0.165	86.0112.18NZx25
			0-16 bar		DC			86.0112.18NZx16
2VE1.6M	G1/8	1.6	0-2 bar	0.07	AC	80	0.165	86.0116.18NZx20
			0-12 bar		DC			86.0116.18NZx12
2VE2M	G1/8	2	0-12 bar	0.1	AC	80	0.165	86.0120.18NZx12
			0-6 bar		DC			86.0120.18NZx06
2VE2.5M	G1/8	2.5	0-6 bar	0.11	AC	80	0.165	86.0125.18NZx06
			0-3 bar		DC			86.0125.18NZx03

PLEASE NOTE: Versions with M10x1 thread are also available upon request

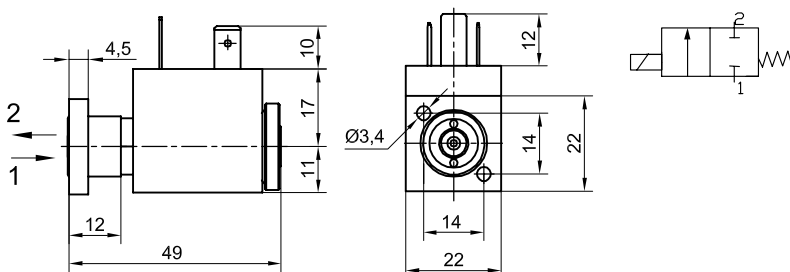

### Electrical protection: IP 65 with connector; IP 00 without connector

Type	Connector	Nominal diameter [mm]	Operating pressure	Flow rate Kv [m³/h]	Voltage	Max. medium temp. [°C]	Weight [kg]	Order number
2SVE1.2M	Flange	1.2	0-12 bar	0.04	AC	90	0.09	86.0312.18NZx
					DC			
2SVE1.6M		1.6	0-8 bar	0.07	AC			86.0316.18NZx
					DC			
2SVE2M		2	0-6 bar	0.1	AC			86.0320.18NZx
					DC			
2SVE2.5M		2.5	0-4 bar	0.12	AC			86.0325.18NZx
					DC			

# TWO-WAY CUT-OFF VALVES

electromagnetically controlled  
directly, normally closed



## TECHNICAL SPECIFICATIONS

<b>Ambient temperature:</b>	-10 to + 50°C
<b>Medium:</b>	water, air, non-aggressive media
<b>Control voltage:</b>	direct current: A - 12V    B - 24 V
<b>(designation "x" in the order number)</b>	50 Hz alternating current: E - 24 V    H - 110 V    J - 230
<b>Materials:</b>	
<b>Body</b>	- brass
<b>Internal parts</b>	- brass, stainless steel
<b>Gasket</b>	- NBR

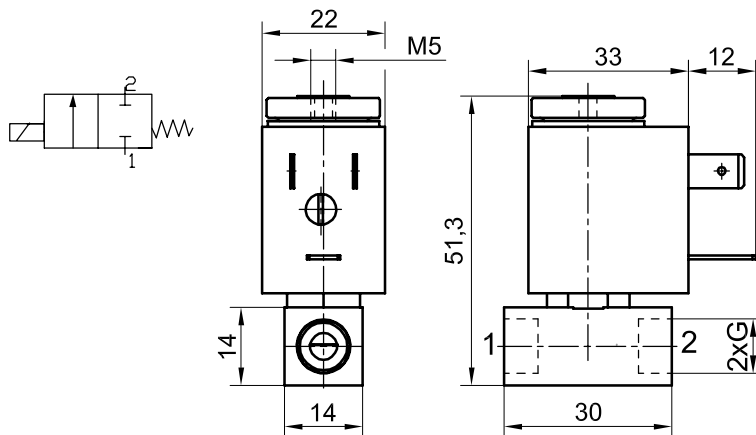

**Electrical protection:** IP 65 with connector; IP 00 without connector

Type	Con- nection thread	Nominal diameter [mm]	Operating pressure	Flow rate Kv [m³/h]	Power con- sumption	Max. medium temp. [°C]	Weight [kg]	Order number
2VE1.2M1	G1/8	1.2	0-16 bar	0.04	5VA 3W	80	0.15	86.0212.18NZx16
2VE1.6M1		1.6	0-10 bar	0.07				86.0216.18NZx10
2VE2M1		2	0-6 bar	0.1				86.0220.18NZx06
2VE2.5M1	G1/8	2.5	0-4 bar	0.11	8.5VA 6W	80	0.15	86.0225.18NZx04
2VE1.2M2		1.2	0-25 bar	0.04				86.0212.18NZx25
2VE1.6M2		1.6	0-20 bar	0.07				86.0216.18NZx20
2VE2M2		2	0-12 bar	0.1				86.0220.18NZx12
2VE2.5M2		2.5	0-6 bar	0.11				86.0225.18NZx06

PLEASE NOTE: Versions with M10x1 thread are also available upon request

## TECHNICAL SPECIFICATIONS

<b>Ambient temperature:</b>	-10 to + 50°C
<b>Medium:</b>	water, air, non-aggressive media
<b>Control voltage</b>	direct current: A - 12V    B - 24V
<b>designation "x" in the order number:</b>	50 Hz alternating current: E - 24V    H - 110V    J - 230
<b>Materials:</b>	
<b>Body</b>	- brass
<b>Internal parts</b>	- stainless steel
<b>Gasket</b>	- NBR, EPDM, FPM

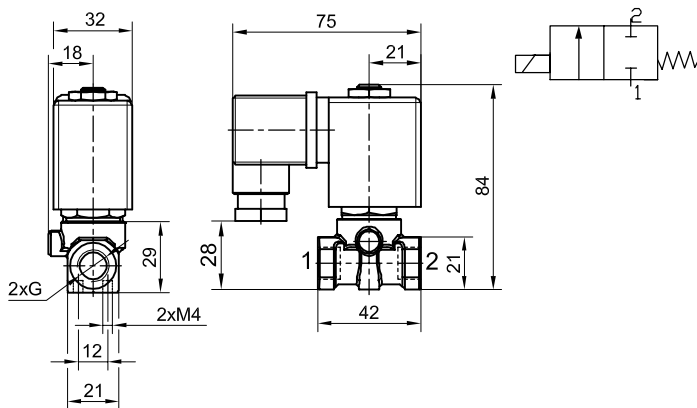

### Electrical protection: IP 65

Type	Revision	Con- nection thread	Nominal diameter [mm]	Operating pressure	Flow rate Kv [m³/h]	Max. medi- um temp. [°C]	Gasket	Voltage	Power con- sumption	Weight [kg]	Order number
2VE2F	N1	G1/4	2	0-30 bar	0.125	90	NBR	AC	18 VA	0.36	86.0401.14NZxN1
	E2			0-25 bar		110	EPDM		15 VA		86.0401.14NZxE2
	F2			0-25 bar		110	FPM		15 VA		86.0401.14NZxF2
2VE2FJ	N1	G1/4	2	0-20 bar	0.125	90	NBR	DC	13 W	0.36	86.0402.14NZxN1
	E2			0-16 bar		110	EPDM		10 W		86.0402.14NZxE2
	F2			0-16 bar		110	FPM		10 W		86.0402.14NZxF2
2VE- 2.5F	N1	G1/4	2.5	0-18 bar	0.18	90	NBR	AC	18 VA	0.36	86.0403.14NZxN1
	E2			0-16 bar		110	EPDM		15 VA		86.0403.14NZxE2
	F2			0-16 bar		110	FPM		15 VA		86.0403.14NZxF2
2VE- 2.5FJ	N1	G1/4	2.5	0-14 bar	0.18	90	NBR	DC	13 W	0.36	86.0404.14NZxN1
	E2			0-10 bar		110	EPDM		10 W		86.0404.14NZxE2
	F2			0-10 bar		110	FPM		10 W		86.0404.14NZxF2
2VE3F	N1	G1/4	3	0-14 bar	0.25	90	NBR	AC	18 VA	0.36	86.0405.14NZxN1
	E2			0-10 bar		110	EPDM		15 VA		86.0405.14NZxE2
	F2			0-10 bar		110	FPM		15 VA		86.0405.14NZxF2
	F3			0-6 bar		130	EPDM		12 VA		86.0405.14NZxE3
2VE3FJ	N1	G1/4	3	0-8 bar	0.25	90	NBR	DC	13 W	0.36	86.0406.14NZxN1
	E2			0-6 bar		110	EPDM		10 W		86.0406.14NZxE2
	F2			0-6 bar		110	FPM		10 W		86.0406.14NZxF2
2VE4F	N1	G1/4	4	0-8 bar	0.3	90	NBR	AC	18 VA	0.36	86.0407.14NZxN1
	E2			0-6 bar		110	EPDM		15 VA		86.0407.14NZxE2
	F2			0-6 bar		110	FPM		15 VA		86.0407.14NZxF2
2VE4FJ	N1	G1/4	4	0-4 bar	0.3	90	NBR	DC	13 W	0.36	86.0408.14NZxN1
	F2			0-2.5 bar		110	EPDM		10 W		86.0408.14NZxF2
2VE6F	N1	G1/4	6	0-2 bar	0.6	90	NBR	AC	18 VA	0.36	86.0409.14NZxN1
	F2			0-1.5 bar		110	EPDM		15 VA		86.0409.14NZxF2
2VE6FJ	N1	G1/4	6	0-1.5 bar	0.6	90	NBR	DC	13 W	0.36	86.0410.14NZxN1
	F2			0-1.2 bar		110	EPDM		10 W		86.0410.14NZxF2

# TWO-WAY CUT-OFF VALVES

electromagnetically controlled  
directly, normally closed



## TECHNICAL SPECIFICATIONS

<b>Ambient temperature:</b>	-10 to + 50°C
<b>Medium:</b>	water, compressed air, non-aggressive media - NBR gasket
<b>Control voltage</b>	A - 12V B - 24 V
<b>designation "x" in the order number:</b>	direct current: 50 Hz alternating current: E - 24V H - 110V J - 230
<b>Materials:</b>	
<b>Body</b>	- brass
<b>Internal parts</b>	- brass, stainless steel
<b>Gasket</b>	- NBR, EPDM

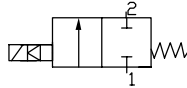
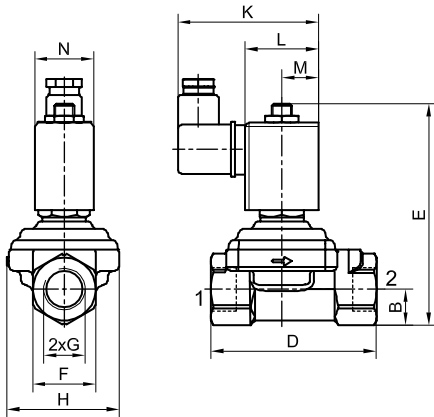

Type	Dimension [mm]									
	G	B	D	E	F	H	K	L	M	N
2VE10DC	G3/8	12	60	98	24	38	75	42	21	32
2VE12DC	G1/2	12	60	98	24	38	75	42	21	32
2VE13DC	G1/2	18	84	109	32	56	78	45	17.5	36
2VE16DC	G3/4	18	84	109	32	56	78	45	17.5	36
2VE25DC	G1	24	112	136	42	70	85	46	23	36
2VE32DC	G1 1/4	24	140	168	60	96	85	46	23	36
2VE40DC	G1 1/2	34	140	168	60	96	85	46	23	36

Electrical protection: IP 65																
Type	Revision	Con- nection thread	Nominal diameter [mm]	Operating pressure	Flow rate Kv [m3/h]	Max. medium temp. [°C]	Gasket	Voltage	Power con- sumption	Weight [kg]	Order number					
2VE10DC	N1	G3/8	10	0-10 bar	1.6	90	NBR	AC	22 VA	0.6	86.1210.38NZxN1					
	E1			0-10 bar		110	EPDM		22 VA		86.1210.38NZxE1					
	E2			0-6 bar		130	EPDM		14 VA		86.1210.38NZxE2					
2VE10DCJ	N1			0-10 bar		90	NBR		18.5 W		86.1210.38NZxN1					
	E1			0-10 bar		110	EPDM		18.5 W		86.1210.38NZxE1					
	E2			0-6 bar		130	EPDM		11.9 W		86.1210.38NZxE2					
2VE12DC	N1	G1/2	12	0-10 bar	2.2	90	NBR	AC	22 VA	0.6	86.1212.12NZxN1					
	E1			0-10 bar		110	EPDM		22 VA		86.1212.12NZxE1					
	E2			0-6 bar		130	EPDM		14 VA		86.1212.12NZxE2					
2VE12DCJ	N1			0-10 bar		90	NBR		18.5 W		86.1212.12NZxN1					
	E1			0-10 bar		110	EPDM		18.5 W		86.1212.12NZxE1					
	E2			0-6 bar		130	EPDM		11.9 W		86.1212.12NZxE2					
2VE13DC	N1	G1/2	13	0-10 bar	3.0	90	NBR	AC	22 VA	0.9	86.1213.12NZxN1					
	E1			0-10 bar		110	EPDM		22 VA		86.1213.12NZxE1					
	E2			0-6 bar		130	EPDM		14 VA		86.1213.12NZxE2					
2VE13DCJ	N1			0-6 bar		90	NBR		18.5 W		86.1213.12NZxN1					
	E1			0-6 bar		110	EPDM		18.5 W		86.1213.12NZxE1					
	E2			0-4 bar		130	EPDM		11.9 W		86.1213.12NZxE2					
2VE16DC	N1	G3/4	18	0-10 bar	4.0	90	NBR	AC	22 VA	1.0	86.1218.34NZxN1					
	E1			0-10 bar		110	EPDM		22 VA		86.1218.34NZxE1					
	E2			0-5 bar		130	EPDM		14 VA		86.1218.34NZxE2					
2VE16DCJ	N1			0-7 bar		90	NBR		18.5 W		86.1218.34NZxN1					
	E1			0-7 bar		110	EPDM		18.5 W		86.1218.34NZxE1					
	E2			0-5 bar		130	EPDM		11.9 W		86.1218.34NZxE2					
2VE25DC	N1	G1	25	0-10 bar	8.5	90	NBR	AC	33 VA	2.2	86.1225.10NZxN1					
	E1			0-10 bar		130	EPDM		33 VA		86.1225.10NZxE1					
	2VE25DCJ			N1		0-6 bar	90		NBR		25 W	86.1225.10NZxN1				
E1				0-6 bar		130	EPDM		25 W		86.1225.10NZxE1					
2VE32DC				N1		G1 1/4	32		0-8 bar		10	90	NBR	AC	33 VA	4.1
	E1			0-8 bar					130			EPDM	33 VA		86.1232.11NZxE1	
	2VE32DCJ	N1	0-5 bar	90	NBR			25 W	86.1232.11NZxN1							
E1		0-5 bar	130	EPDM	25 W			86.1232.11NZxE1								
2VE40DC		N1	G1 1/2	40	0-8 bar			10	90	NBR		AC	33 VA		4.1	
	E1	0-8 bar			130				EPDM	33 VA			86.1240.13NZxE1			
	2VE40DCJ	N1			0-5 bar	90	NBR		25 W	86.1240.13NZxN1						
E1		0-5 bar			130	EPDM	25 W		86.1240.13NZxE1							

## TECHNICAL SPECIFICATIONS

<b>Ambient temperature:</b> -10 to + 50°C	
<b>Medium:</b> combustible gases	
direct current:	
<b>Control voltage</b>	<b>A</b> - 12V <b>B</b> - 24 V
<b>designation "x" in the order number:</b> 50 Hz alternating current:	
	<b>E</b> - 24V <b>H</b> - 110V <b>J</b> - 230
<b>Materials:</b>	
<b>Body</b>	- brass
<b>Internal parts</b>	- stainless steel
<b>Gasket</b>	- NBR

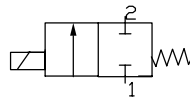
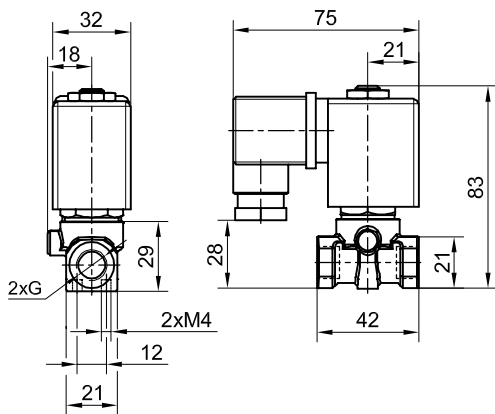

Electrical protection: IP 65 Power consumption 15VA; 10W								
Type	Connec- tion thread	Nominal diameter [mm]	Operating pressure	Flow rate Kv [m3/h]	Max. medium temp. [°C]	Voltage	Weight [kg]	Order number
2VE6F G	G1/4	6	0-0.5 bar	0.6	50	AC	0.36	86.0606.14NZxN1
2VE6F GJ	G1/4	6	0-0.5 bar	0.5	50	DC	0.36	



# TWO-WAY CUT-OFF VALVES

electromagnetically controlled  
directly, normally open



## TECHNICAL SPECIFICATIONS

<b>Ambient temperature:</b>	-10 to + 50°C		
<b>Medium:</b>	water, air, non-aggressive media		
<b>Control voltage</b>	<b>A</b> - 12V	<b>B</b> - 24 V	direct current:
<b>designation "x" in the order number:</b>	50 Hz alternating current:		
	<b>E</b> - 24V	<b>H</b> - 110 V	<b>J</b> - 230
<b>Materials:</b>			
<b>Body</b>	- brass		
<b>Internal parts</b>	- stainless steel		
<b>Gasket</b>	- NBR, EPDM, FPM		

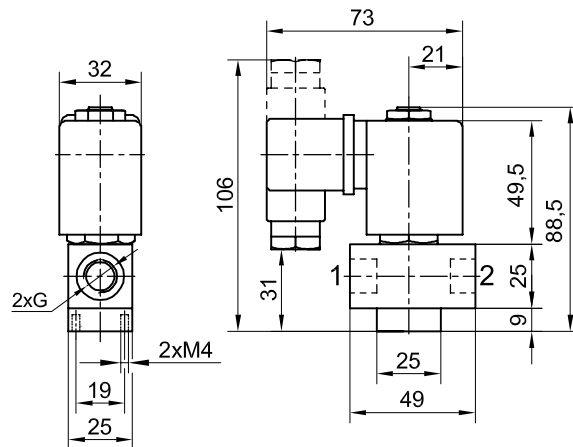
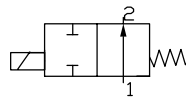

### Electrical protection: IP 65

Type	Revision	Thread Connections	Nominal diameter [mm]	Operating pressure	Flow rate Kv [m³/h]	Max. medium temp. [°C]	Gasket	Voltage	Power consumption	Weight [kg]	Order number
2VE2.5IF	N2	G1/4	2.5	0-6 bar	0.15	90 110	NBR	AC	15 VA	0.4	86.0525.14NOxN2
	E2						EPDM				86.0525.14NOxE2
	F2						FPM				86.0525.14NOxF2
2VE2.5IFJ	N2	G1/4	2,5	0-6 bar	0.15	90 110	NBR	DC	10 W	0.4	86.0525.14NOxN2
	E2						EPDM				86.0525.14NOxE2
	F2						FPM				86.0525.14NOxF2
2VE6IF	N2	G1/4	6	0-1 bar	0.45	90 110	NBR	AC	15 VA	0.4	86.0560.14NOxN2
	E2						EPDM				86.0560.14NOxE2
	F2						FPM				86.0560.14NOxF2
2VE6IFJ	N2	G1/4	6	0-1 bar	0.45	90 110	NBR	AC DC	10 VA	0.4	86.0560.14NOxN2
	E2						EPDM				86.0560.14NOxE2
	F2						FPM				86.0560.14NOxF2

## TECHNICAL SPECIFICATIONS

<b>Ambient temperature:</b>	-10 to +40°C
<b>Medium:</b>	air (2VE50VDBA), water (2VE50VDBB), steam (2VE DSB)
<b>Control voltage</b>	direct current: A - 12V    B - 24V
<b>designation "x" in the order number:</b>	50 Hz alternating current: E - 24V    H - 110V    J - 230
<b>Operating position:</b>	vertical with coil on top
<b>Materials:</b>	
<b>Body</b>	- cast iron
<b>Internal parts</b>	- brass, stainless steel
<b>Gasket</b>	- as in the table below

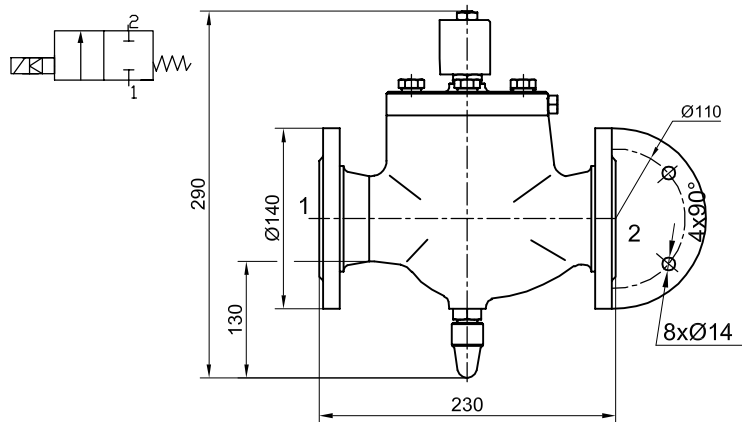

<b>Electrical protection: IP 65 Power consumption: 24VA; 18.5W</b>								
<b>Gasket material: NBR</b>								
Type	Connector	Nominal diameter [mm]	Operating pressure	Flow rate Kv [m³/h]	Max. medium temp. [°C]	Voltage	Weight [kg]	Order number
2VE50DBA	flange	50	0.5-10 bar	25	60	AC / DC	11	86.0950.NZx
2VE50DBB	flange	50	1-10 bar	25	60	AC / DC	12	86.0950.NZx

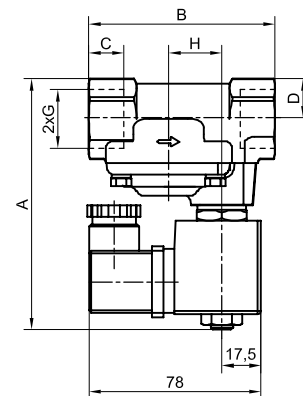
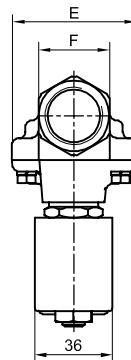
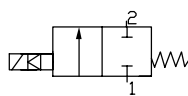

Type	Dimension [mm]						
	G	A	B	D	E	F	H
2VE13DSB	G1/2	119	84	18	56	32	24
2VE16DSB	G3/4	119	84	18	56	32	24
2VE25DSB	G1	128	112	24	70	41	31

<b>Electrical protection: IP 65 Power consumption: 8.8VA; 4W</b>							
<b>Gasket material: Teflon, IT panel, FPM</b>							
Type	Connection thread	Nominal diameter [mm]	Operating pressure	Flow rate Kv [m³/h]	Max. medium temp. [°C]	Weight [kg]	Order number
2VE13DSB	G1/2	16	0.5-6 bar	2.5	160	1.3	86.1116.12NZx
2VE16DSB	G3/4			3.1		1.3	86.1116.34NZx
2VE25DSB	G1	25		7.8		2.0	86.1125.10NZx

# TWO-WAY CUT-OFF VALVES

electromagnetically controlled  
indirectly, normally closed



## TECHNICAL SPECIFICATIONS

<b>Ambient temperature:</b> -10 to +50°C
<b>Medium:</b> water, air, non-aggressive media
direct current:
<b>Control voltage:</b> A - 12V B - 24V
(designation "x" in the order number) 50 Hz alternating current:
E - 24V H - 110V J - 230
<b>Materials:</b>
<b>Body</b> - brass
<b>Internal parts</b> - brass, stainless steel
<b>Gasket</b> - NBR

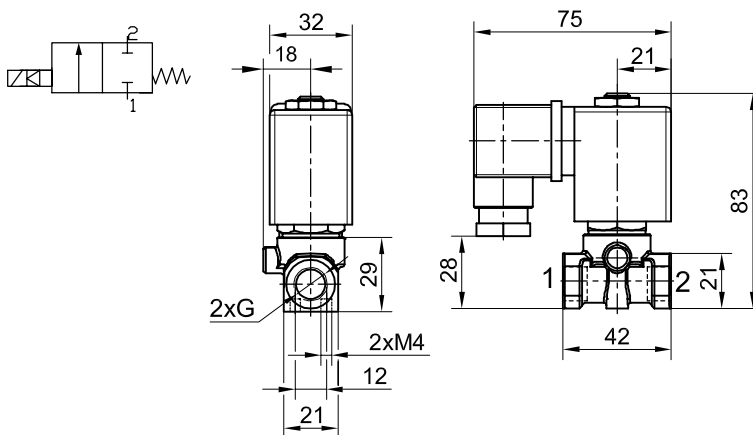

### Electrical protection: IP 65

Type	Revision	Connection thread	Nominal diameter [mm]	Operating pressure	Flow rate Kv [m3/h]	Max. medium temp. [°C]	Gasket	Voltage	Power consumption	Weight [kg]	Order number
2VE6DF	N1	G1/4	6	0.05–16 bar	0.56	90	NBR	AC	18VA	0.36	86.0706.14NZxN1
	E2			0.05–16 bar		110	EPDM		15VA		86.0706.14NZxE2
	E3			0.05–6 bar		125	EPDM		12VA		86.0706.14NZxE3
2VE6DFJ	N1	G1/4	6	0.05–14 bar	0.56	90	NBR	DC	13W	0.36	86.0706.14NZxN1
	E2			0.05–10 bar		110	EPDM		10W		86.0706.14NZxE2

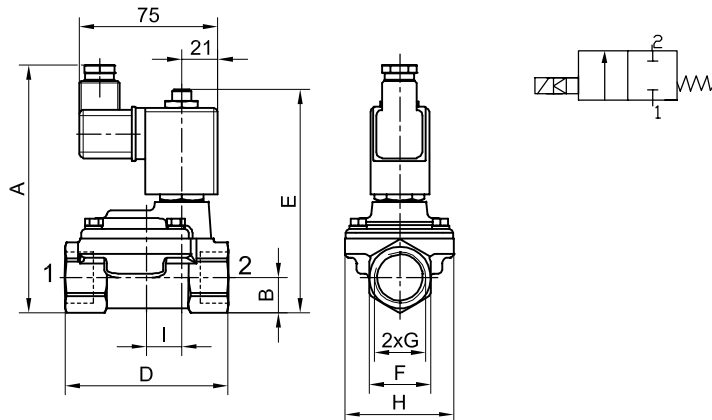

Type	Dimension [mm]							
	G	A	B	D	E	F	H	I
2VE10DA	G3/8	124	12	60	105	24	38	0
2VE12DA	G1/2	124	12	60	105	24	38	0
2VE13DA	G1/2	133	16	84	114	32	56	24
2VE16DA	G3/4	133	16	84	114	32	56	24
2VE25DA	G1	146	18	112	127	41	70	31
2VE32DA	G1 1/4	177	22	140	158	60	96	41
2VE40DA	G1 1/2	177	22	140	158	60	96	41
2VE50DA	G2	198	35	163	179	72	112	55

**Electrical protection: IP 65**

Type	Revision	Con- nection thread	Nominal diameter [mm]	Operating pressure	Flow rate Kv [m <sup>3</sup> /h]	Max. medium temp. [°C]	Gasket	Voltage	Power con- sumption	Weight [kg]	Order number
2VE10DA	N1	G3/8	10	0.3-16 bar	1.6	90	NBR	AC DC	18 VA / 13W	0.7	86.0810.38NZxN1
	E2							AC	15 VA		86.0810.38NZxE2
	E3							AC DC	12 VA / 10W		86.0810.38NZxE3
2VE12DA	N1	G1/2	12	0.3-16 bar	2.2	90	NBR	AC DC	18 VA / 13W	1.1	86.0812.12NZxN1
	E2							AC	15 VA		86.0812.12NZxE2
	E3							AC DC	12 VA / 10W		86.0812.12NZxE3
2VE13DA	N1	G1/2	13	0.3-16 bar	3	90	NBR	AC DC	18 VA / 13W	1.1	86.0813.12NZxN1
	E2							AC	15 VA		86.0813.12NZxE2
	E3							AC DC	12 VA / 10W		86.0813.12NZxE3
2VE16DA	N1	G3/4	16	0.3-16 bar	3.6	90	NBR	AC DC	18 VA / 13W	1.0	86.0816.34NZxN1
	E2							AC	15 VA		86.0816.34NZxE2
	E3							AC DC	12 VA / 10W		86.0816.34NZxE3
2VE25DA	N1	G1	25	0.3-16 bar	8.5	90	NBR	AC DC	18 VA / 13W	1.8	86.0825.10NZxN1
	E2							AC	15 VA		86.0825.10NZxE2
	E3							AC DC	12 VA / 10W		86.0825.10NZxE3
2VE32DA	N2	G1 1/4	32	0.3-10 bar	17.5	90	NBR	AC DC	15 VA	3.6	86.0832.11NZxN2
	E2							EPDM	10 W		86.0832.11NZxE2
2VE40DA	N2	G1 1/2	40	0.3-10 bar	18.5	90	NBR	AC DC	15 VA	3.2	86.0840.13NZxN2
	E2							EPDM	10 W		86.0840.13NZxE2
2VE50DA	N1	G2	50	0.3-10 bar	38	90	NBR	AC DC	18 VA	5.0	86.0850.20NZxN1
	E1							EPDM	13 W		86.0850.20NZxE1

# TWO-WAY CUT-OFF VALVES

electromagnetically controlled  
indirectly, normally open



## TECHNICAL SPECIFICATIONS

<b>Ambient temperature:</b>	-10 to + 50°C	
<b>Medium:</b>	water, compressed air, non-aggressive media	
<b>Control voltage</b>	direct current: A - 12V    B - 24 V	
<b>designation "x" in the order number:</b>	50 Hz alternating current: E - 24V    H - 110 V    J - 230	
<b>Materials:</b>		
<b>Body</b>	- brass	
<b>Internal parts</b>	- brass, stainless steel	
<b>Gasket</b>	- NBR, EPDM	

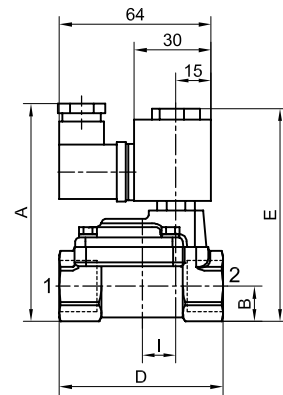
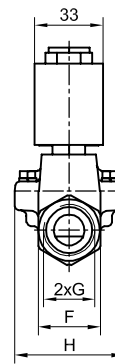
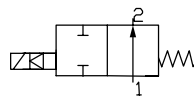

Type	Dimension [mm]							
	G	A	B	D	E	F	H	I
2VE6IDA	G1/4	133	12	60	114	24	38	0
2VE10IDA	G3/8	133	12	60	114	24	38	0
2VE13IDA	G1/2	142	16	84	123	32	56	24
2VE16IDA	G3/4	142	16	84	123	32	56	24
2VE25IDA	G1	155	18	112	136	41	70	31
2VE32IDA	G1 1/4	186	22	140	167	60	96	41
2VE40IDA	G1 1/2	186	22	140	167	60	96	41
2VE50IDA	G2	207	35	163	188	72	112	55

7

## Electrical protection: IP 65

Type	Revision	Con-nection thread	Nominal diameter [mm]	Operating pressure	Flow rate Kv [m3/h]	Max. medium temp. [°C]	Gasket	Voltage	Power consumption	Weight [kg]	Order number
2VE16IDA	N1	G1/4	10	0.2-12 bar	0.95	90	NBR	AC / DC	15 VA/16W	0.8	86.1010.14NOxN1
	E1					130	EPDM				86.1010.14NOxE1
2VE10IDA	N1	G3/8	10	0.2-12 bar	1.6	90	NBR	AC / DC	15 VA/16W	0.75	86.1010.38NOxN1
	E1					130	EPDM				86.1010.38NOxE1
2VE13IDA	N1	G1/2	13	0.2-12 bar	3	90	NBR	AC / DC	15 VA/16W	1.1	86.1013.12NOxN1
	E1					130	EPDM				86.1013.12NOxE1
2VE16IDA	N1	G3/4	16	0.2-12 bar	3.6	90	NBR	AC / DC	15 VA/16W	1.0	86.1016.34NOxN1
	E1					130	EPDM				86.1016.34NOxE1
2VE25IDA	N1	G1	25	0.2-12 bar	8.5	90	NBR	AC / DC	15 VA/16W	1.8	86.1025.10NOxN1
	E1					130	EPDM				86.1025.10NOxE1
2VE32IDA	N1	G1 1/4	32	0.2-12 bar	17.5	90	NBR	AC / DC	15 VA/16W	3.6	86.1032.11NOxN2
	E1					130	EPDM				86.1032.11NOxE1
2VE40IDA	N1	G1 1/2	40	0.2-12 bar	18.5	90	NBR	AC / DC	15 VA/16W	3.2	86.1040.13NOxN2
	E1					130	EPDM				86.1040.13NOxE1
2VE50IDA	N1	G2	50	0.2-10 bar	38	90	NBR	AC / DC	15 VA/16W	5.0	86.1050.20NOxN2
	E1					130	EPDM				86.1050.20NOxE1

## TECHNICAL SPECIFICATIONS

<b>Ambient temperature:</b>	-10 to + 50°C
<b>Medium:</b>	water, compressed air, non-aggressive media
<b>Control voltage</b>	<b>A</b> - 12V <b>B</b> - 24 V
<b>designation "x" in the order number:</b>	50 Hz alternating current: <b>E</b> - 24V <b>H</b> - 110 V <b>J</b> - 230
<b>Materials:</b>	
<b>Body</b>	- brass
<b>Internal parts</b>	- stainless steel
<b>Gasket</b>	- NBR

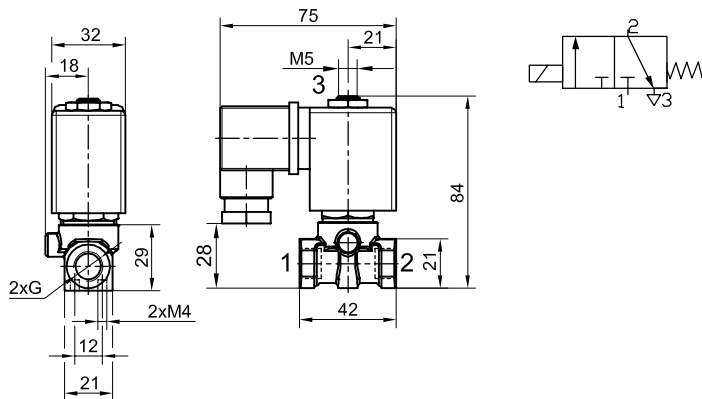

### Electrical protection: IP 65 Power consumption: 15VA; 10W

Type	Connection thread	Nominal diameter [mm]	Operating pressure	Flow rate Kv [m3/h]	Max. medium temp. [°C]	Voltage	Weight [kg]	Order number
3VE1.6F	G1/4	1.6	0-14 bar	0.08	80	AC / DC	0.36	87.0516.14NZx
3VE2F		2	0-10 bar	0.12		AC / DC		87.0520.14NZx
3VE2.5F		2.5	0-6 bar	0.18		AC / DC		87.0525.14NZx

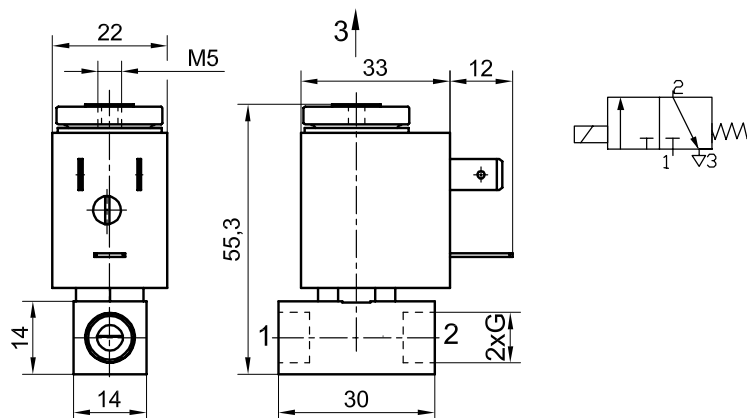

### Electrical protection: IP 00 with connector

Type	Thread Connections	Nominal diameter [mm]	Operating pressure	Flow rate Kv [m3/h]	Power consumption	Max. medium temp. [°C]	Weight [kg]	Order number
3VE1.2M1	G1/8	1.2	0-10 bar	0.04	5VA 3 W	80	0.15	87.0212.18NZx1
3VE1.6M1		1.6	0-5 bar	0.06				87.0216.18NZx1
3VE2M1		2	0-3 bar	0.09				87.0220.18NZx1
3VE1.2M2	G1/8	1.2	0-12 bar	0.04	8.5VA 6 W	80	0.15	87.0212.18NZx2
3VE1.6M2		1.6	0-8 bar	0.06				87.0216.18NZx2
3VE2M2		2	0-5 bar	0.09				87.0220.18NZx2

PLEASE NOTE: Versions with M10x1 thread are also available upon request

# THREE-WAY CUT-OFF VALVES

electromagnetically controlled  
directly, normally closed



## TECHNICAL SPECIFICATIONS

<b>Ambient temperature:</b>	-10 to +50°C	
<b>Medium:</b>	water, compressed air, non-aggressive media	
<b>Control voltage</b>	direct current: A - 12V    B - 24V	
<b>designation "x" in the order number:</b>	50 Hz alternating current: E - 24V    H - 110V    J - 230	
<b>Materials:</b>		
<b>Body</b>	- brass	
<b>Internal parts</b>	- stainless steel	
<b>Gasket</b>	- NBR	

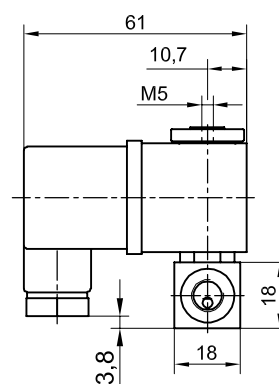
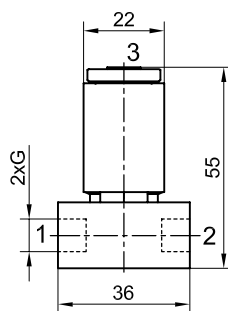
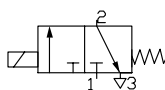

### Electrical protection: IP 65 Power consumption: 8.5VA; 6W

Type	Connection thread	Nominal diameter [mm]	Operating pressure	Flow rate Kv [m3/h]	Voltage	Max. medium temp. [°C]	Weight [kg]	Order number
3VE1,2M	G1/8	1.2	0-10 bar	0.04	AC / DC	80	0.15	87.0112.18NZxN1
3VE1,6M		1.6	0-8 bar	0.06	AC / DC			87.0116.18NZxN1
3VE2M		2	0-6 bar	0.09	AC / DC			87.0120.18NZxN1

PLEASE NOTE: Versions with M10x1 thread are also available upon request

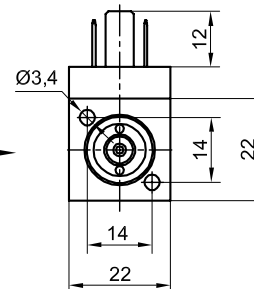
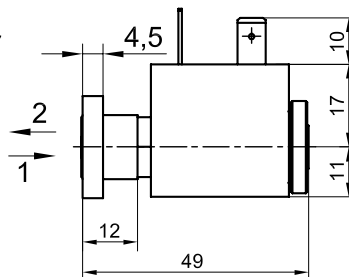
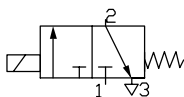

### Electrical protection: IP65 with connector; IP00 without connector Power consumption: 8.5VA; 6W

Type	Connector	Nominal diameter [mm]	Operating pressure	Flow rate Kv [m3/h]	Max. medium temp. [°C]	Voltage	Weight [kg]	Order number
3SVE1,2M	Flange	1.2	0-12 bar	0.04	90	AC / DC	0.09	87.0412.NZx
3SVE1,6M		1.6	0-8 bar	0.07		AC / DC		87.0416.NZx
3SVE2M	Flange	2.0	0-6 bar	0.1		AC / DC		87.0420.NZx

## TECHNICAL SPECIFICATIONS

<b>Ambient temperature:</b>	-10 to + 50°C	
<b>Medium:</b>	water, compressed air, non-aggressive media	
<b>Control voltage</b>	<b>A</b> - 12V	<b>B</b> - 24 V
<b>designation "x" in the order number:</b>	50 Hz alternating current: <b>E</b> - 24 V <b>H</b> - 110 V <b>J</b> - 230	
<b>Materials:</b>		
<b>Body</b>	- brass	
<b>Internal parts</b>	- stainless steel	
<b>Gasket</b>	- NBR	

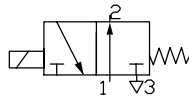
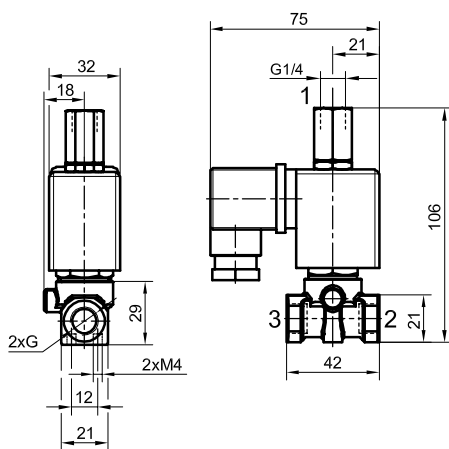

### Electrical protection: IP 65 Power consumption: 15VA; 10W

Type	Con- nection thread	Nominal diameter [mm]	Operating pressure	Flow rate Kv [m3/h]	Max. medium temp. [°C]	Voltage	Weight [kg]	Order number
3VE2IF	G1/4	2	0-10 bar	0.12	80	AC / DC	0.38	87.0620.14NOx
3VE2.5IF		2.5	0-6 bar	0.15		AC / DC		87.0625.14NOx





## TECHNICAL SPECIFICATIONS

<b>Ambient temperature:</b>	-10 to +40°C
<b>Medium:</b>	water, compressed air, non-aggressive media
<b>Control voltage</b>	A - 12V    B - 24V
<b>designation "x" in the order number:</b>	50 Hz alternating current: E - 24V    H - 110V    J - 230
<b>Construction materials:</b>	
<b>Body</b>	- brass
<b>Internal parts</b>	- stainless steel
<b>Gasket</b>	- NBR

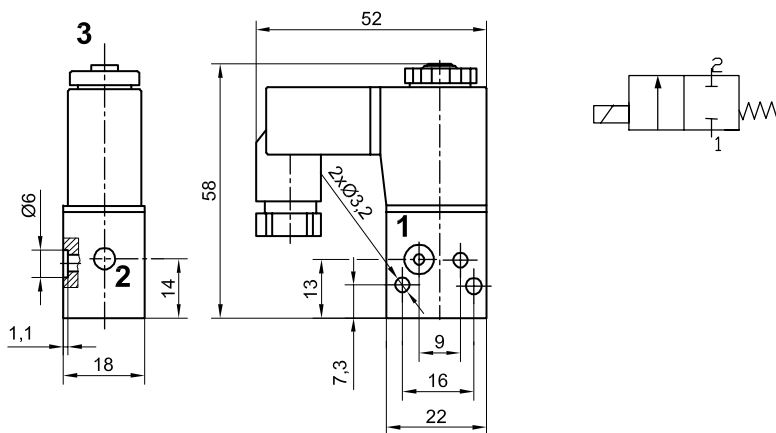

<b>Electrical protection: IP65 with connector; IP00 without connector Power consumption: 4VA; 2.9W</b>								
Type	Connection thread	Nominal diameter [mm]	Operating pressure	Flow rate Kv [m3/h]	Max. medium temp. [°C]	Voltage	Weight [kg]	Order number
2VE2C	M5	2	0-5 bar	0.07	80	AC / DC	0.13	87.0720.M5NZx

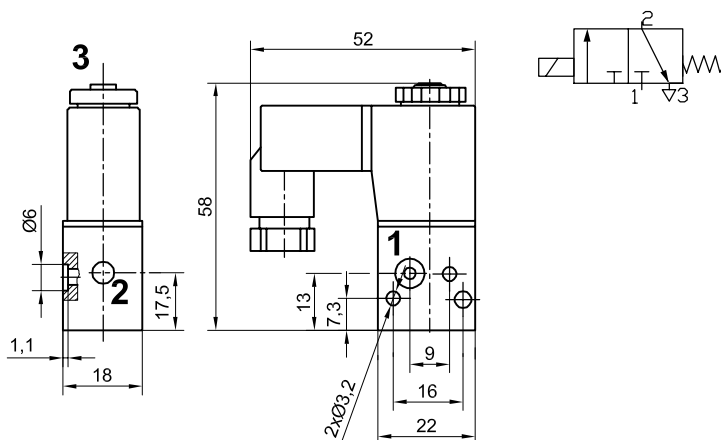

<b>Electrical protection: IP65 with connector; IP00 without connector Power consumption: 4VA; 2.9W</b>								
Type	Connection thread	Nominal diameter [mm]	Operating pressure	Flow rate Kv [m3/h]	Max. medium temp. [°C]	Voltage	Weight [kg]	Order number
3VE1	M5	1	0-8 bar	0.026	80	AC / DC	0.13	87.0820.M5NZx

# SOLENOID VALVE COILS



## COIL - TYPE EVI 7/9

Technical specifications	Valve type	Voltage	Power consumption	Type	Order number
Electrical connection: AMP 6.3x0.8 Power supply tolerance: ±10% Insulation class: F Load: 100% Weight: 0.073 kg	2VExM 2SVExM 3VExM 3SVExM	12V 50 / 60Hz	8.5/ 7VA (50 / 60 Hz)	0709SA 012xx ZB	664034500
		24V 50 / 60Hz		0709SA 024xx ZB	664034600
		42V 50 / 60Hz		0709SA 042xx ZB	664034700
		110V 50 / 60Hz		0709SA 110xx ZB	664034800
		230V 50 / 60Hz		0709SA 230xx ZB	664034900
		12V=		0709SD 012xx ZB	664035000
	24V=	0709SD 024xx ZB	664033700		
	48V=	0709SD 048xx ZB	664035100		
	110V=	0709SD 010xx ZB	664035200		

## COIL - TYPE 24 1241

Technical specifications	Valve type	Voltage	Power consumption	Type	Order number	
Electrical connection: DIN43650-A Power supply tolerance: ±10% Insulation class: F Load: 100% Weight: 0.15 kg	2VExFx 2SVExiFx 2VExxDA 3VExFx 3VExiF	12V 50 / 60Hz	15 VA (22VA)	24124105	624124105	
		24V 50 / 60Hz		24124104	624124104	
		42V 50 / 60Hz		24124103	624124103	
		110V 50 / 60Hz		24124102	624124102	
		230V 50 / 60Hz	24124101	624124101		
		24V 50 / 60Hz	24124109	624124109		
		42V 50 / 60Hz	24124108	624124108		
		110V 50 / 60Hz	24124107	624124107		
		230V 50 / 60Hz	24124106	624124106		
		12V 50 / 60Hz	24124135	624124135		
		24V 50 / 60Hz	24124134	624124134		
		42V 50 / 60Hz	24124133	624124133		
	110V 50 / 60Hz	24124132	624124132			
	230V 50 / 60Hz	24124131	624124131			
	PLEASE NOTE: Coils for 60 Hz and other supply voltages upon request	2VExFJ 2SVExiFJ 2VExxDA 3VExFx 3VExiF	12V=	10 W	24124155	624124155
			24V=		24124154	624124154
			48V=		24124153	624124153
		2VExFJ 2SVExiFJ 2VExxDA	110V=	13W	24124152	624124152
			230V=		24124151	624124151
			12V=		24124161	624124161
			24V=		24124159	624124159
48V=			24124158		624124158	
110V=			24124157		624124157	
230V=	24124156	624124156				

## COIL - TYPE 16-36P

Technical specifications	Valve type	Power consumption	Type - voltage	Order number
Electrical connection: DIN43650-A Power supply tolerance: ±10% Insulation class: F Load: 100% Weight: 0.15 kg	2VE25DC 2VE32DC 2VE40DC	33 VA	16-36P 33-24VAC / 50Hz	664033601
			16-36P 33-110VAC / 50Hz	664033600
			16-36P 33-230VAC / 50Hz	664033300
	2VE25DCJ 2VE32DCJ 2VE40DCJ	25 W	16-36P 33-24VDC	664033400
			16-36P 33-110VDC	664035300
			16-36P 33-230VDC	664035400

## COIL - TYPE 16-36P

Technical specifications	Valve type	Power consumption	Type - voltage	Order number	
Electrical connection: DIN43650-A Power supply tolerance: ±10% Insulation class: F Load: 100% Weight: 0.25kg	2VE50DFA 2VE50DFB	24 VA 50/60Hz	13-36P 24-24VAC / 50Hz / 60Hz	64033200	
			13-36P 24-42VAC / 50Hz / 60Hz	64033100	
			13-36P 24-110VAC / 50Hz / 60Hz	64033000	
			13-36P 24-230VAC / 50Hz / 60Hz	64032900	
	2VE13DC 2VE16DC	21VA, 50Hz 17.3VA, 60Hz	13-36P 21-24VAC / 50Hz / 60Hz	64031600	
			13-36P 21-42VAC / 50Hz / 60Hz	64031500	
			13-36P 21-110VAC / 50Hz / 60Hz	64032300	
	2VE13DC 2VE16DC	14VA, 50Hz 12VA, 60Hz	13-36P 21-230VAC / 50Hz / 60Hz	64032200	
			13-36P 14-24VAC / 50Hz / 60Hz	64032300	
			13-36P 14-110VAC / 50Hz / 60Hz	64032200	
	2VE10DSB 2VE13DSB 2VE16DSB	8.8VA, 50Hz 7.5VA, 60Hz	13-36P 14-230VAC / 50Hz / 60Hz	64032100	
			13-36P 8.8-24VAC / 50Hz / 60Hz	64032700	
			13-36P 8.8-110VAC / 50Hz / 60Hz	64032600	
	2VE10DCJ 2VE13DCJ 2VE16DCJ	18.5 W	13-36P 8.8-220VAC / 50Hz / 60Hz	64032500	
			13-36P 18.5 - 12VDC	64032000	
			13-36P 18.5 - 24VDC	64031900	
			13-36P 18.5 - 110VDC	64031800	
	2VExxDCJ 2VExxDSB	11.5W 4W	13-36P 18.5 - 220VDC	64031700	
			13-36P 11.5 - 24VDC	64032400	
				13-36P 4 - 24VDC	64032800

## COIL - TYPE B6NA

Technical specifications	Valve type	Power consumption	Type - voltage	Order number
Electrical connection: DIN43650-A Power supply tolerance: $\pm 10\%$ Insulation class: F Load: 100% Weight: 0.2kg	2VExxIDA	15 VA	B6 NA 24VAC / 50Hz	664035500
			B6 NA 110VAC / 50Hz	664035600
			B6 NA 230VAC / 50Hz	664035400
		16 W	B6 NA 24VDC	664035300

## COIL - TYPE B6NA

Technical specifications	Valve type	Power consumption	Type - voltage	Order number
Electrical connection: DIN43650-A Power supply tolerance: $\pm 10\%$ Insulation class: F Load: 100% Weight: 0.2kg	2VExxIDA	15 VA	B6 NA 24VAC / 50Hz	664035500
			B6 NA 110VAC / 50Hz	664035600
			B6 NA 230VAC / 50Hz	664035400
		16 W	B6 NA 24VDC	664035300

## CONNECTIONS TO COILS

### CONNECTION - TYPE DIN 43650-B

Technical specifications	Revision	Power consumption	For coil - type	Type	Order number
Number of pins: 2x power supply, 1x ground Nominal load: 10A Connection: M20x1.5 Coverage: IP 65	Standard <sup>1)</sup>	Umax 250V	EVI 7/9	6-12142-0000	64031182
	With LED indicator <sup>2)</sup>	24V		6-12142-0502	64031185
		220V		6-12142-0505	64031196

1) Solenoid valves are supplied with standard connection

2) Upon request. Connector with LED voltage indicator can be supplied

### CONNECTION - TYPE DIN 43650-A

Technical specifications	Revision	Power consumption	For coil - type	Type	Order number
Number of pins: 2x power supply, 1x ground Nominal load: 10V Connection: M20x1.5 Coverage: IP 65	Standard <sup>1)</sup>	Umax 250V	241241 13-36P 16-36P B6NA	6-11142-0000	63450201
	With LED indicator <sup>2)</sup>	24V		6-11442-0502	63450079
		220V		6-11442-0504	63450202
		230V		6-11442-0505	63450203
	With full wave rectifier bridge	230V		6-41142-0506	63450087

1) Solenoid valves are supplied with standard connection

2) Upon request. Connector with LED voltage indicator can be supplied

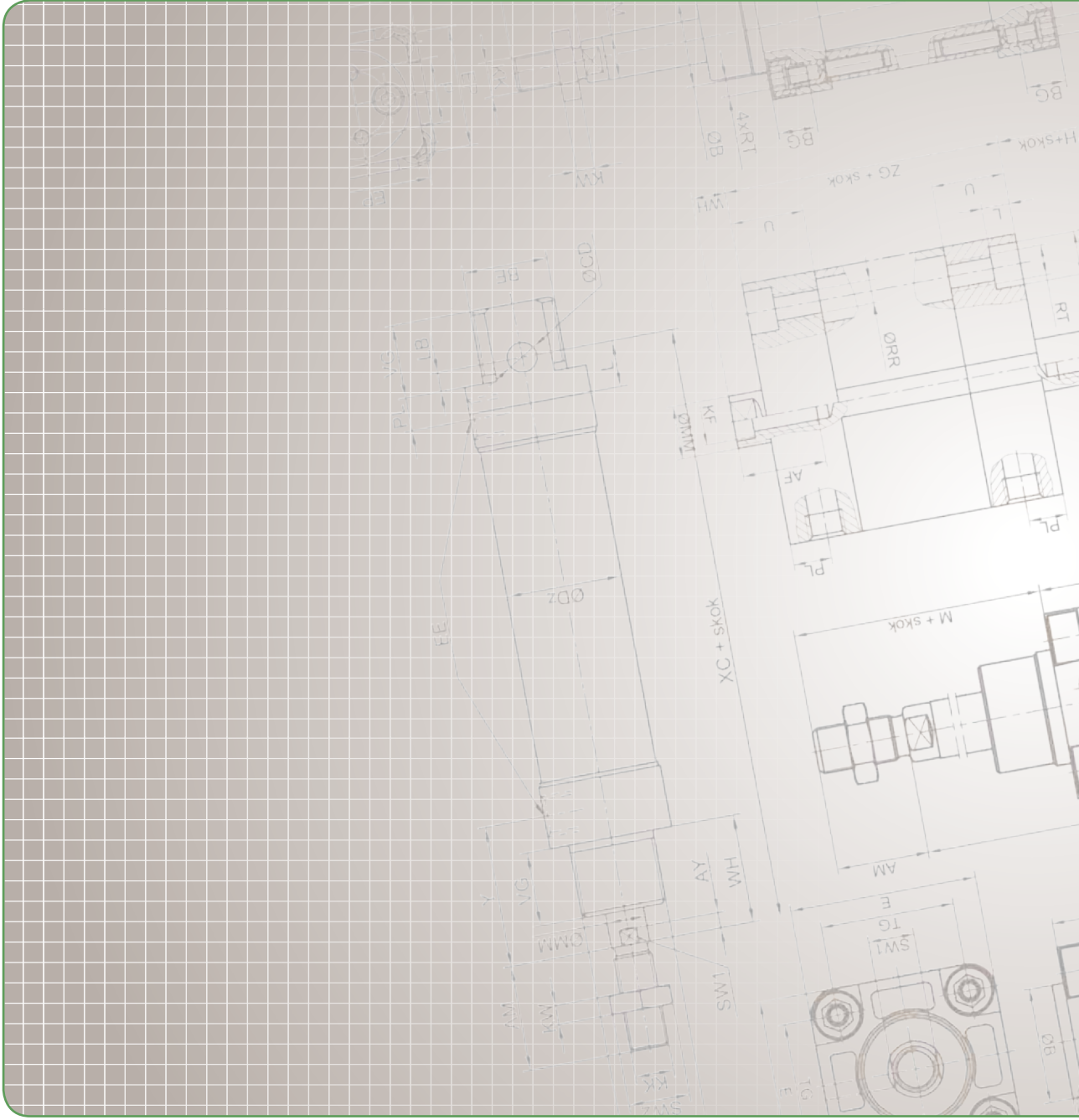



OFFER FOR MINING  
AND RAILWAY INDUSTRIES



# PNEUMATIC PRODUCTION CENTER "PREMA" SPÓŁKA AKCYJNA

PPC "PREMA" S.A. IS A MANUFACTURER OF M1 AND M2 GROUP AND CATEGORY EQUIPMENT, WHICH ARE DESIGNED FOR OPERATION IN AREAS AT RISK OF METHANE AND/OR COAL DUST EXPLOSION:

- Pneumatic solenoid valves series ATE G ½", ¾"
- Compressed air preparation blocks PSP G ¼", ½", ¾", 1"
- Filters, lubricators, filter-lubricators, compressed air reduction valves G ½", ¾", 1"
- Pneumatic actuators series ISO D32 – D320
- Pneumatic actuators series CNOMO D32 – D200
- Long stroke pneumatic actuators in the range D140 – D200
- Special actuators to meet customer requirements
- Auxiliary valves type PZR G ⅛" – G ¼"
- Pneumatic, mechanical DTP and DTM G ⅛" – G ¼" type valves
- Double acting hydraulic actuators D25 – D160





# PNEUMATIC PRODUCTION CENTER "PREMA" SPÓŁKA AKCYJNA

Nasza firma jest największym polskim producentem pneumatyki siłowej i sterującej stosowanej do mechanizacji i automatyzacji procesów produkcyjnych w wielu gałęziach przemysłu.

Ponad cztery dekady doświadczenia pozwalają nam tworzyć i rozwijać wyroby przystosowane do pracy w najcięższych warunkach występujących w transporcie kolejowym.

Z szerokiej gamy naszych produktów szczególnie polecamy elementy wspomagającego układu pneumatycznego wagonu towarowego serii Falns takie jak: pulpity sterownicze, siłowniki pneumatyczne, filtry przygotowania sprężonego powietrza oraz serię płytkowych zaworów rozdzielających G1/2".

Problemy naszych klientów traktujemy, jako priorytety a dzięki dobrej komunikacji i elastyczności powstają unikatowe projekty, które są doceniane w Polsce i za granicą.

Nasze kwalifikacje są poparte świadectwami: Instytutu Pojazdów Szynowych „Tabor” oraz świadectwem kwalifikacji CNTK akceptowanym przez Urząd Kolei Niemieckich Eisenbahn-Bundesamt.

Jakość naszych produktów opieramy na systemie zarządzania ISO 9001:2015 certyfikowanym przez TÜV Management Service GmbH.

Our company is the largest Polish producer of pneumatic elements used in mechanization and automation of production processes in various fields of industry. With over 40 years of experience we are qualified to design and develop highly durable products for use in the most aggressive conditions on railway systems.

From a wide range of our products we especially recommend the pneumatic aid system for the Falns wagon series, such as control panels, pneumatic cylinders, compressed air filters and a line of semi-rotary lever valve G1/2".

We treat our customers' problems as priorities and, thanks to good communication procedures, know-how and flexibility, we are able to create unique solutions. Our projects are valued throughout Poland and abroad.

The qualifications of our staff are validated by The Rail Vehicles Institute "TABOR" certificate and the CNTK qualification approved by the German railway office EBA (Eisenbahn Bundesamt).

We base the quality and reliability of our products on the ISO 9001:2015 quality management system certified by TÜV Management Service GmbH.

**Special offer for the railways industry**  
**Poland's largest manufacturer of pneumatic components**  
**More than 40 years of experience**

- Pneumatics
- Hydraulics
- Automation
- Control systems
- Special designs



Pneumatic Production Center  
"PREMA"  
Spółka Akcyjna  
ul. Wapiennikowa 90  
25-101 Kielce  
tel. head office: 41/361-95-24  
fax: 41/361-91-08  
www.prema.pl

**Looking forward to doing  
business with you**



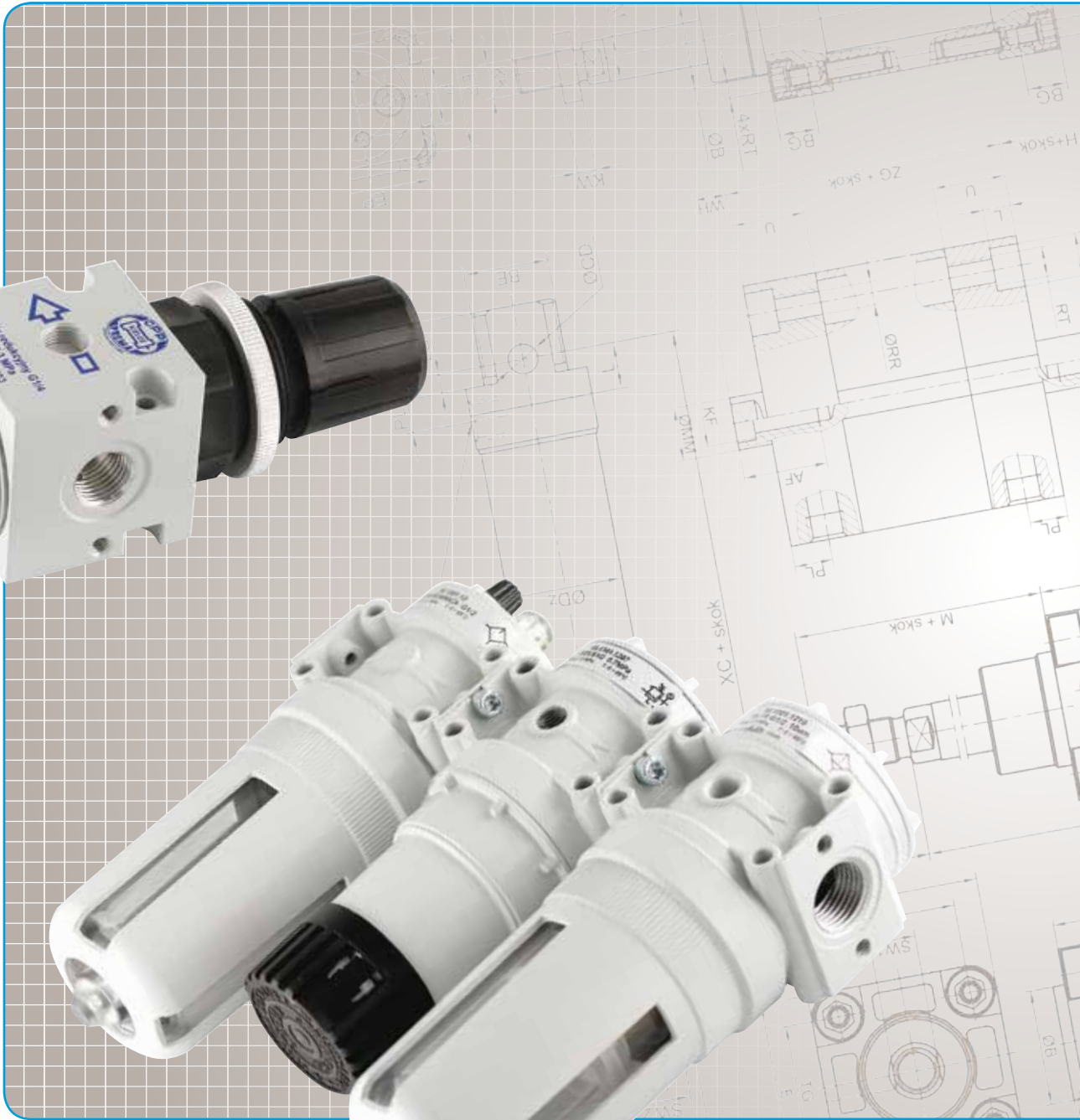

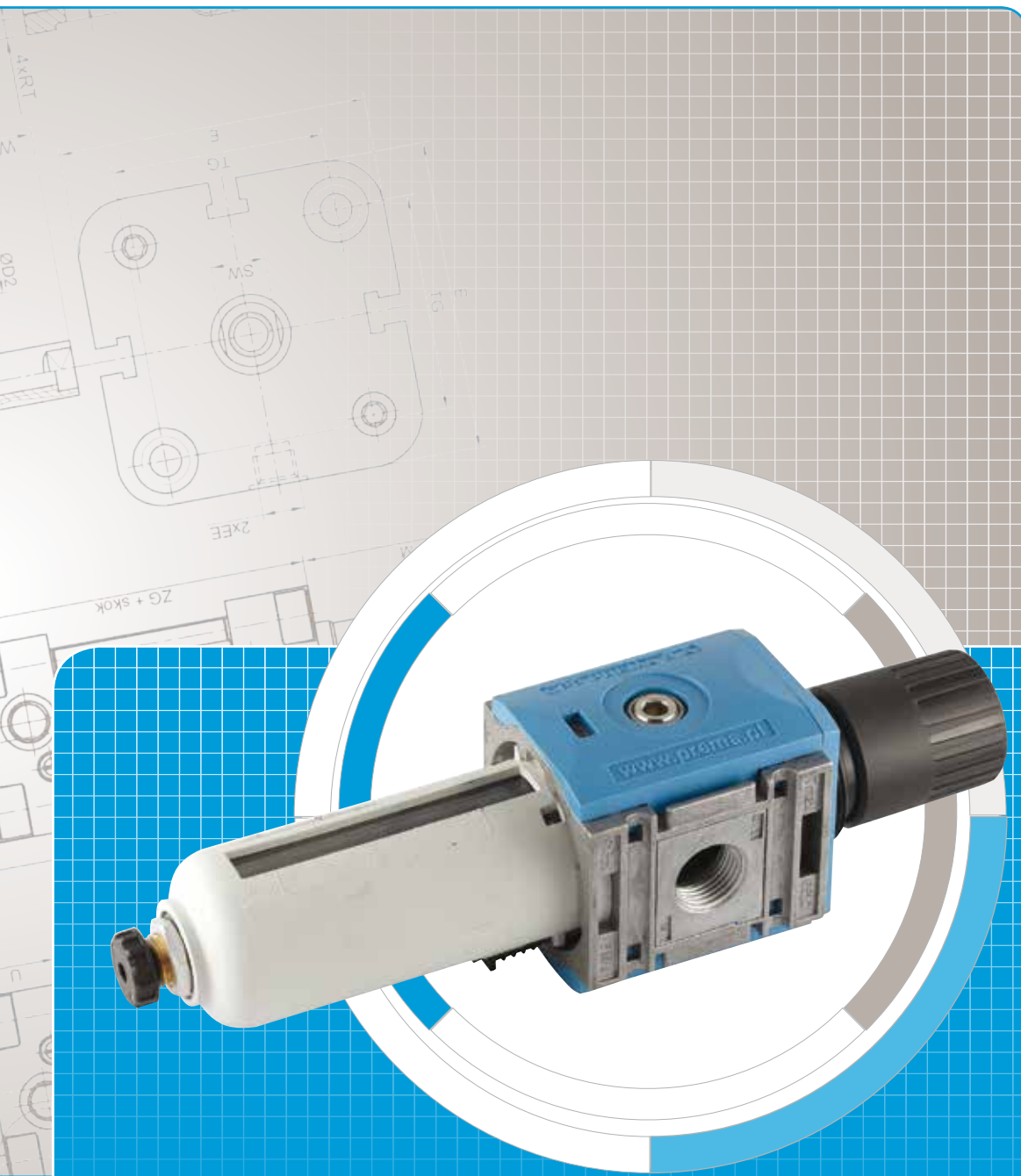







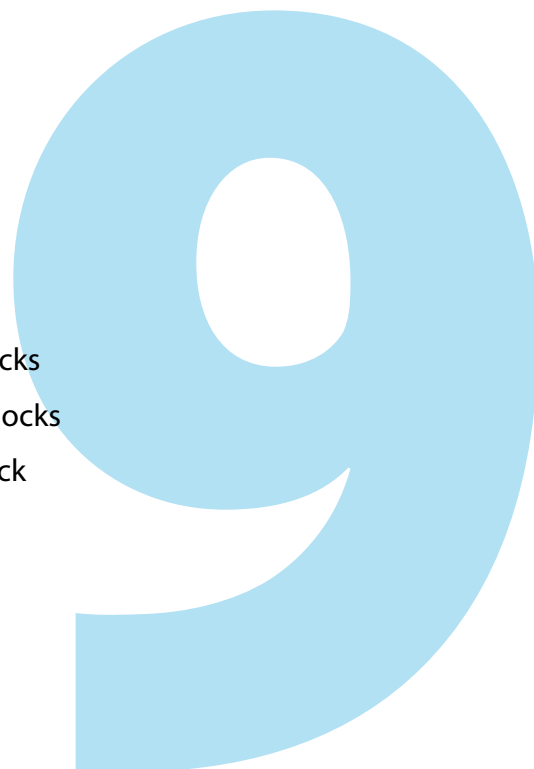

















# COMPRESSED AIR PREPARATION UNITS

## Compressed air preparation units











- 9.01.** Filters
- 9.02.** Pressure regulators
- 9.03.** Lubricators
- 9.04.** Filtration and reduction units
- 9.05.** Two-element compressed air preparation blocks
- 9.06.** Three-element compressed air preparation blocks
- 9.07.** Five-element compressed air preparation block
- 9.08.** Cut-off valves
- 9.09.** Distribution valves
- 9.10.** Additional equipment
  - 9.10.01.** Pneumo-electric relays
  - 9.10.02.** Time relay
  - 9.10.03.** SOFT START valve
  - 9.10.04.** Pressure sensor
  - 9.10.05.** Control switch and decompression valves
  - 9.10.06.** Pressure gauges
  - 9.10.07.** Reducing valves for pressure gauges
- 9.11.** Fasteners
- 9.12.** Repair kits















	MINI series	CLASSIC series	NOVA series	MAXI series
<b>Compressed air filter</b>	<p>G1/4</p>  <p>page 9.01.01.</p>	<p>G3/8 – G3/4</p>  <p>page 9.01.02.</p>	<p>G3/8 – G1/2</p>  <p>page 9.01.03.</p>	<p>G1 – G2</p>  <p>page 9.01.04.</p>
<b>Compressed air reducing valve</b>	<p>G1/4</p>  <p>page 9.02.01.</p>	<p>G3/8 – G3/4</p>  <p>page 9.02.02.</p>	<p>G3/8 – G1/2</p>  <p>page 9.02.03.</p>	<p>G1 – G1 1/2</p>  <p>page 9.02.04.</p>
<b>Compressed air lubricator</b>	<p>G1/4</p>  <p>page 9.03.01.</p>	<p>G3/8 – G3/4</p>  <p>page 9.03.02.</p>	<p>G3/8 – G1/2</p>  <p>page 9.03.03.</p>	<p>G1 – G1 1/2</p>  <p>page 9.03.04.</p>
<b>Compressed air filtration and reduction unit</b>	<p>G1/4</p>  <p>page 9.04.01.</p>	<p>G3/8 – G3/4</p>  <p>page 9.04.02.</p>	<p>G3/8 – G1/2</p>  <p>page 9.04.03.</p>	<p>G1</p>  <p>page 9.04.04.</p>
<b>Two-element compressed air preparation block</b>	<p>G1/4</p>  <p>page 9.05.01.</p>	<p>G3/8 – G3/4</p>  <p>page 9.05.02.</p>	<p>G3/8 – G1/2</p>  <p>page 9.05.03.</p>	<p>G1</p>  <p>page 9.05.04.</p>
<b>Three-element compressed air preparation block</b>		<p>G3/8 – G3/4</p>  <p>page 9.06.01.</p>	<p>G3/8 – G1/2</p>  <p>page 9.06.02.</p>	<p>G1 – G1 1/2</p>  <p>page 9.06.03.</p>
<b>Five-element compressed air preparation block</b>			<p>G3/8 – G1/2</p>  <p>page 9.07.01.</p>	

# COMPRESSED AIR PREPARATION UNITS



<p><b>NOVA series cut-off valve</b></p>		<p>G3/8 – G1/2</p>	<p>page 9.08</p>
<p><b>NOVA series distribution valve</b></p>		<p>G3/8 – G3/4</p>	<p>page 9.09</p>
<p><b>Pneumo-electric relay</b></p>		<p>G1/4</p>	<p>page 9.10.01.</p>
<p><b>Soft Start valve</b></p>		<p>G1/2</p>	<p>page 9.10.02.</p>
<p><b>Time relay</b></p>		<p>G1/4</p>	<p>page 9.10.03.</p>
<p><b>Pressure sensor</b></p>		<p>G3/8 – G1/2</p>	<p>page 9.10.04.</p>
<p><b>Control switch</b></p>		<p>G1/4</p>	<p>page 9.10.05.</p>
<p><b>Decompression valves</b></p>		<p>G1/4 - G1/2</p>	<p>page 9.10.05</p>
<p><b>Pressure gauges</b></p>		<p>G1/8-G1/2</p>	<p>page 9.10.06.</p>
<p><b>Reducing valves for pressure gauges</b></p>		<p>G1/2</p>	<p>page 9.10.07.</p>

					
	MINI series Compressed air preparation block	page 9.11.01.02	-	-	page 9.11.01.02
	CLASSIC series Compressed air preparation block	page 9.11.01.01	page 9.11.01.01	page 9.11.01.01	-

					
	NOVA series Compressed air preparation block	page 9.11.02.01	page 9.11.02.01	-	page 9.11.02.02
	NOVA series Three-element compressed air preparation block	page 9.11.02.01	page 9.11.02.01	page 9.11.02.02	page 9.11.02.02



### TECHNICAL SPECIFICATIONS

<b>Maximum inlet pressure:</b> 12 bar	
<b>Medium:</b> Compressed air or other technical gas neutral to the structural materials used	
<b>Operating temperature range:</b> 0 to + 65°C	
<b>Operating position:</b> vertical, tank down	
<b>Construction materials:</b>	
<p><b>Body</b> - aluminium alloy</p> <p><b>Tanks</b> - transparent polycarbonate</p> <p><b>Filter cartridge</b> - bronze sinter</p> <p><b>Wheel, cover, hood</b> - plastic</p> <p><b>Seals</b> - oil resistant rubber</p>	
<b>Connection thread:</b> G1/8; G 1/4	

Please note: other material versions (e.g. stainless steel, acid-resistant steel, brass) available after technical consultation.



### DIMENSIONS

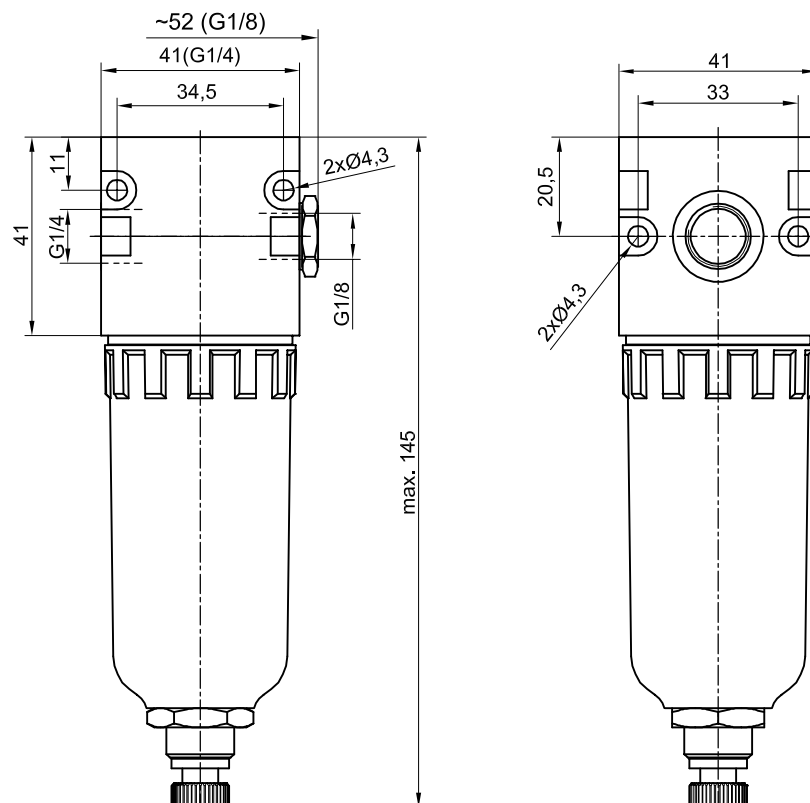

Please note: The G1/8 connection thread is obtained by screwing a R1/4 x G1/8 reducer screw plug into the connection threads



### FLOW CHARACTERISTICS

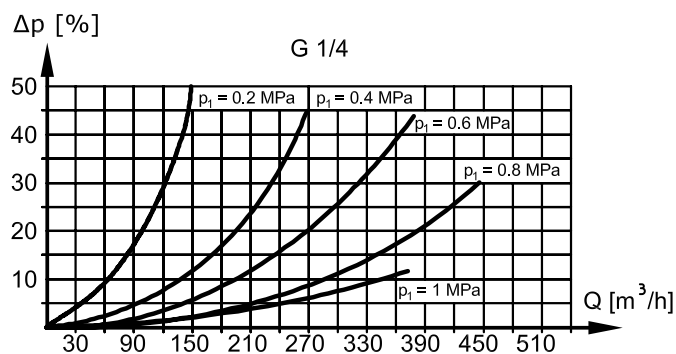

### ORDER NUMBERS

Connection thread	Micron rating [μm]	Nominal flow [6 bar]	Order number
G1/8	5	450 l/min	50.0001.1805
	10		50.0001.1810
	40		50.0001.1840
G1/4	5	1470 l/min	50.0001.1405
	10		50.0001.1410
	40		50.0001.1440

### ORDERING PROCEDURE

In your order, please specify: the name, connection thread, order number and number of pieces, e.g.:  
**MINI G1/4 compressed air filter, no. 50.0001.1410 1 pc.**

### ADDITIONAL ELEMENTS:

Fasteners for MINI compressed air filter	page 9.11.01.01.01-02
Repair kits for MINI compressed air filter	page 9.12.02

### TECHNICAL SPECIFICATIONS

<b>Maximum inlet pressure:</b>	12 bar	
<b>Medium:</b>	Compressed air or other technical gas neutral to the structural materials used	
<b>Operating temperature range:</b>	0 to + 65°C	
<b>Operating position:</b>	vertical, tank down	
<b>Construction materials:</b>		
<b>Body, cover</b>	- zinc alloy	
<b>Tanks</b>	- transparent polycarbonate	
<b>Wheel, cover, hood</b>	- plastic	
<b>Filter cartridge</b>	- bronze sinter	
<b>Seals</b>	- oil resistant rubber (NBR)	
<b>Caps</b>	- aluminium alloy	
<b>Connection thread:</b>	G3/8; G1/2; G3/4	

Please note: other material versions (e.g. stainless steel, acid-resistant steel, brass) available after technical consultation. Available with automatic condensate drain.



### DIMENSIONS

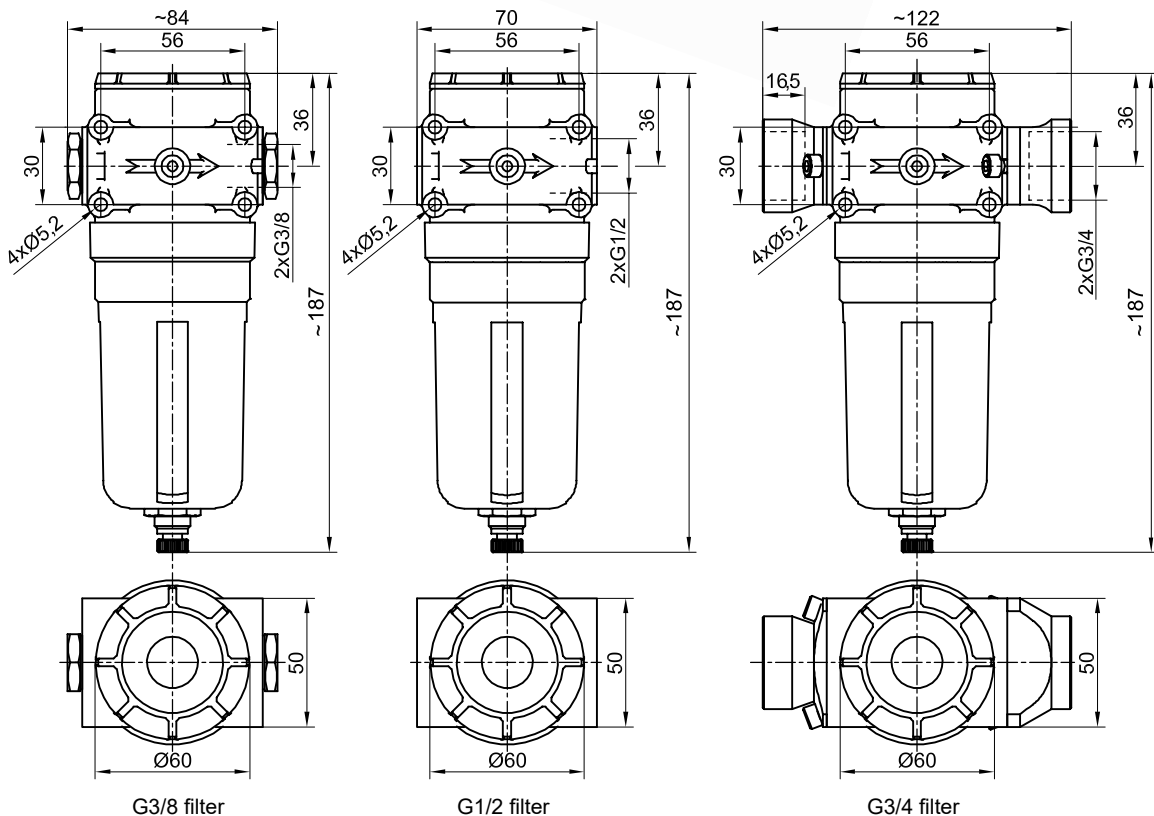

### FLOW CHARACTERISTICS

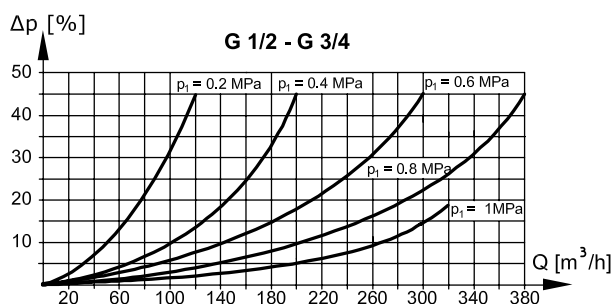
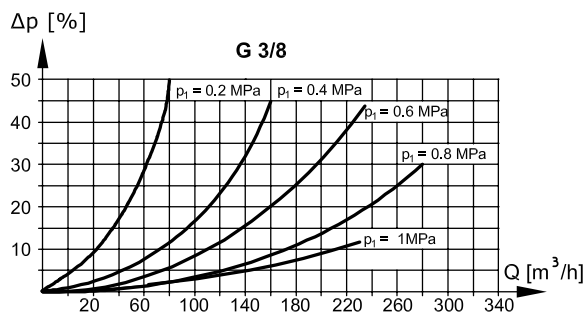

### ORDER NUMBERS

Connection thread	Micron rating [μm]	Nominal flow [6 bar]	Order number
G3/8	5	1660 l/min	50.1001.3805
	10		50.1001.3810
	40		50.1001.3840
G1/2	5	2080 l/min	50.1001.1205
	10		50.1001.1210
	40		50.1001.1240
G3/4	5	2080 l/min	50.1001.3405
	10		50.1001.3410
	40		50.1001.3440

### ORDERING PROCEDURE

In your order, please specify: the name, connection thread, order number and number of pieces, e.g.:  
**CLASSIC G3/4 compressed air filter, no. 50.1001.3410 1 pc.**

### ADDITIONAL ELEMENTS:

Fasteners for CLASSIC compressed air filter	page 9.11.01.01.01-02
Repair kits for CLASSIC compressed air filter	page 9.12.01

### TECHNICAL SPECIFICATIONS

<b>Maximum inlet pressure:</b> 16 bar	
<b>Medium:</b> Compressed air or other technical gas neutral to the structural materials used	
<b>Operating temperature range:</b> 0 to + 65°C	
<b>Operating position:</b> vertical, tank down	
<b>Construction materials:</b>	
<p><b>Body</b> - aluminium alloy</p> <p><b>Tank</b> - transparent polycarbonate</p> <p><b>Tank cover</b> - plastic</p> <p><b>Body cover</b> - plastic</p> <p><b>Seals</b> - oil resistant rubber</p>	
<b>Connection thread:</b> G3/8; G1/2	



### DIMENSIONS

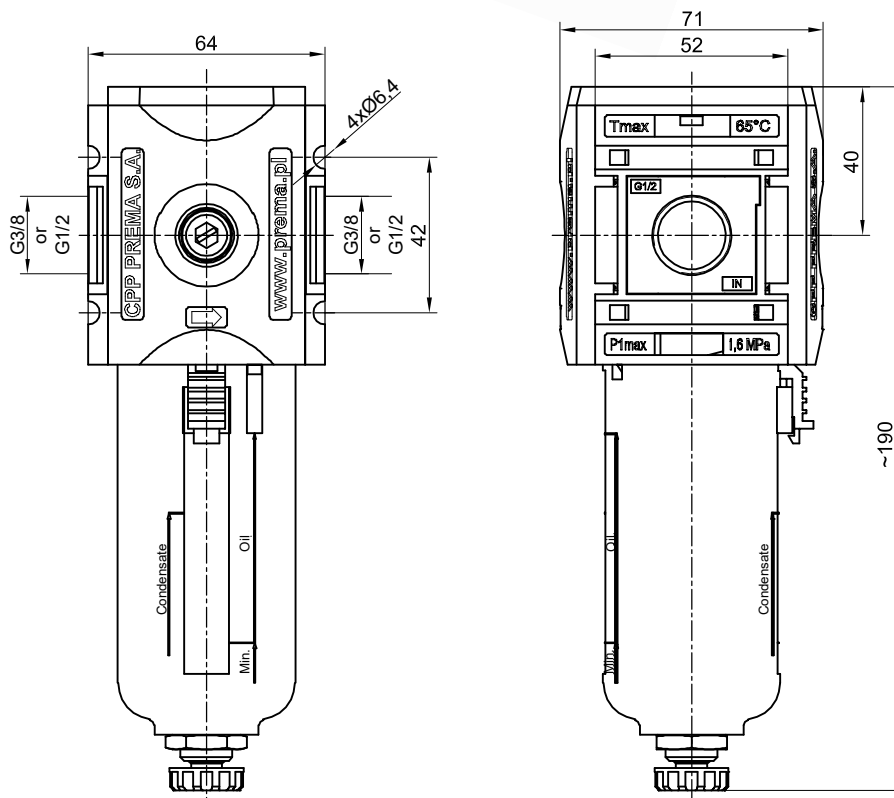

### FLOW CHARACTERISTICS

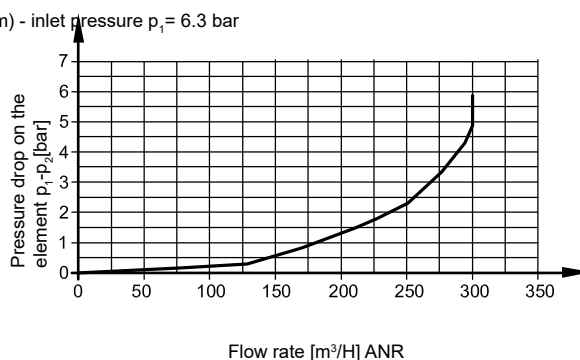
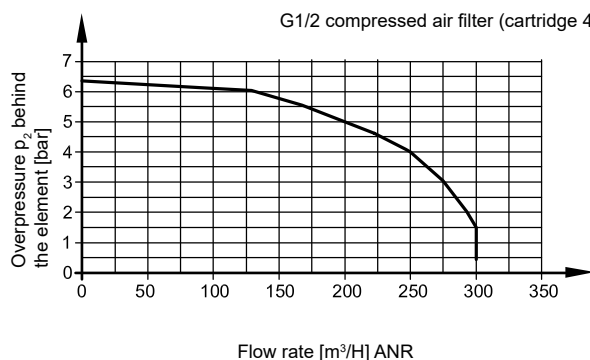

### ORDER NUMBERS

Connection thread	Micron rating [μm]	Nominal flow [6 bar]	Order number
G3/8	5	1660 l/min	50.2001.3805
	10		50.2001.3810
	40		50.2001.3840
G1/2	5	2080 l/min	50.2001.1205
	10		50.2001.1210
	40		50.2001.1240

### ORDERING PROCEDURE

In your order, please specify: the name, connection thread, order number and number of pieces, e.g.:  
**NOVA G1/2 compressed air filter no. 50.2001.1210 1 pc.**

### ADDITIONAL ELEMENTS:

Fasteners for NOVA compressed air filter	page 9.11.02.01-02
Repair kits for NOVA compressed air filter	page 9.12.03

### TECHNICAL SPECIFICATIONS

<b>Maximum inlet pressure:</b> 16 bar	
<b>Medium:</b> Compressed air or other technical gas neutral to the structural materials used	
<b>Outlet pressure range:</b> 0.5 – 16 bar	
<b>Operating temperature range:</b> 0 to + 60°C	
<b>Operating position:</b> vertical	
<b>Deposit tank capacity:</b> 300 cm <sup>3</sup>	
<b>Construction materials:</b> <b>Body</b> - zinc alloy <b>Tank</b> - according to the table <b>Seals</b> - NBR	
<b>Connection thread:</b> G1; G1 1/4; G1 1/2; G2	

### DIMENSIONS

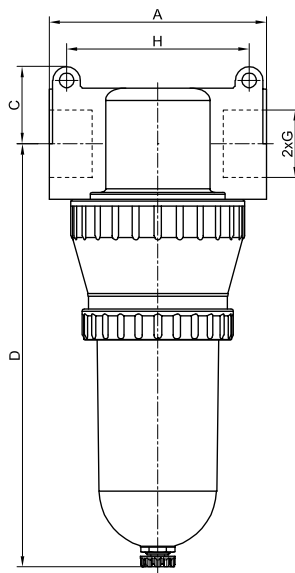

### ORDER NUMBERS

Connection thread	Tank material	Nominal flow [6 bar]	A	C	D	H	Order number
<b>Flow rate: 4000l/min</b>							
<b>G1</b>	plastic	4,000 l/min	90	26.5	169.9	50	<b>80.0001.100959</b>
	metal		90	26.5	169.9	50	<b>80.0001.100977</b>
	plastic with metal cover		90	26.5	172.5	50	<b>80.0001.100968</b>
<b>Flow rate: 12500l/min</b>							
<b>G1 1/4</b>	plastic	12,500 l/min	125	36.5	243.4	105	<b>80.0001.100960</b>
	metal		125	36.5	243.4	105	<b>80.0001.100978</b>
	plastic with metal cover		125	36.5	246	105	<b>80.0001.100969</b>
<b>G1 1/2</b>	plastic	12,500 l/min	125	36.5	243.4	105	<b>80.0001.100961</b>
	metal		125	36.5	243.4	105	<b>80.0001.100979</b>
	plastic with metal cover		125	36.5	246	105	<b>80.0001.100970</b>
<b>Flow rate: 30000l/min</b>							
<b>G2</b>	plastic	30,000 l/min	148	41	394.4	120	<b>80.0001.100962</b>
	metal		148	41	394.4	120	<b>80.0001.100980</b>
	plastic with metal cover		148	41	397	120	<b>80.0001.100971</b>

### ORDERING PROCEDURE

In your order, please specify: the name, connection thread, order number and number of pieces, e.g.:

**MAXI G1 compressed air filter, no. 80.0001.100968 1 pc.**



### TECHNICAL SPECIFICATIONS

<b>Maximum inlet pressure:</b>	12 bar	
<b>Medium:</b>	Compressed air or other technical gas neutral to the structural materials used	
<b>Outlet pressure range:</b>	0.5—3.0; 0.5—7.0; 0.5—10 bar	
<b>Operating temperature range:</b>	0 to + 65°C	
<b>Operating position:</b>	any position	
<b>Construction materials:</b>		
<b>Body, cap, cover</b> - aluminium alloy <b>Head</b> - brass <b>Valve plug</b> - plastic <b>Seals, diaphragm</b> - oil resistant rubber		
<b>Connection thread:</b>	G1/8; G1/4	

Please note: other material versions (e.g. stainless steel, acid-resistant steel, brass) available after technical consultation.



### DIMENSIONS

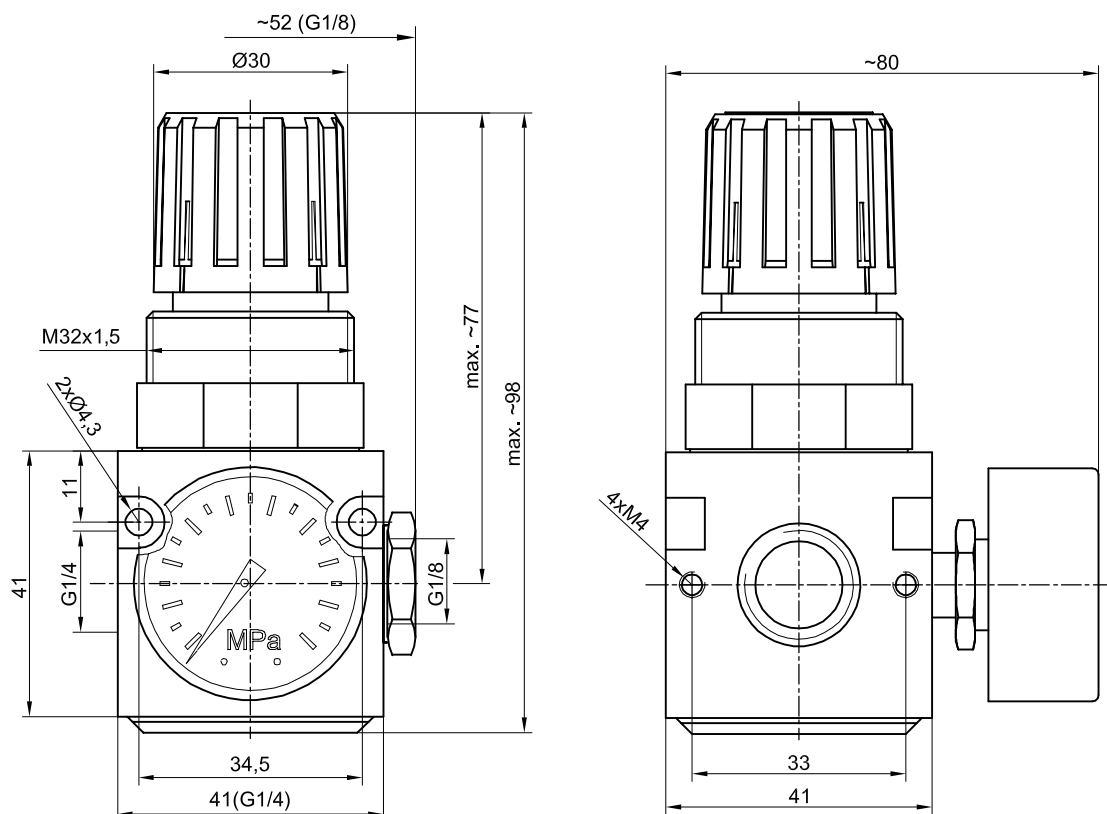

**Please note:** The G 1/8 connection thread is obtained by screwing a R1/4 x G1/8 reducer screw plug into the connection threads



### FLOW AND CONTROL CHARACTERISTICS

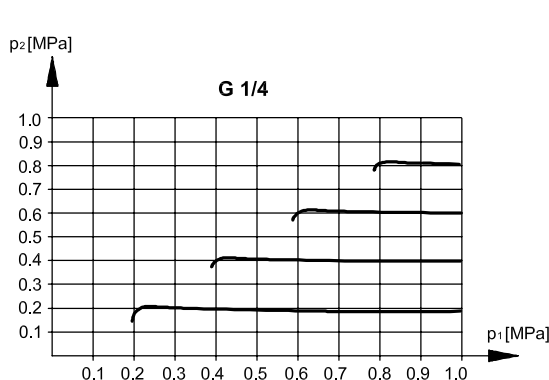

Control characteristics

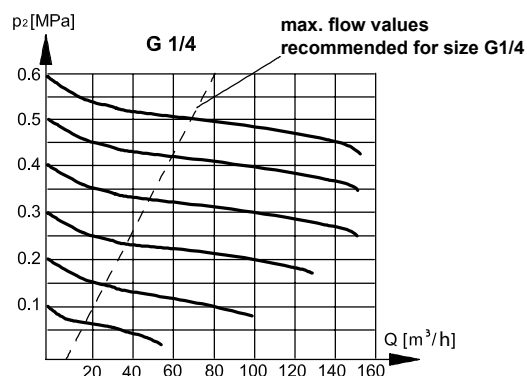

Flow characteristics

### ORDER NUMBERS

Connection thread	Outlet pressure range [MPa]	Nominal flow [6 bar]	Order number standard
G1/8	0.05 — 0.30	1,110 l/min	50.0101.1803
	0.05 — 0.70		50.0101.1807
	0.05 — 1.00		50.0101.1810
G1/4	0.05 — 0.30	1,650 l/min	50.0101.1403
	0.05 — 0.70		50.0101.1407
	0.05 — 1.00		50.0101.1410

### ORDERING PROCEDURE

In your order, please specify: the name, connection thread, order number and number of pieces, e.g.:  
**MINI G1/4 reducing valve, no. 50.0101.1410 1 pc.**

### ADDITIONAL ELEMENTS:

Fasteners for MINI reducing valve	page 9.11.01.01.01-02
Repair kits for MINI reducing valve	page 9.12.05

### TECHNICAL SPECIFICATIONS

<b>Maximum inlet pressure:</b> 18 bar	
<b>Medium:</b> Compressed air or other technical gas neutral to the structural materials used	
<b>Outlet pressure range:</b> 0.5—3.0; 0.5—7.0; 0.5—10.0 bar	
<b>Operating temperature range:</b> 0 to + 65°C	
<b>Operating position:</b> any position	
<b>Construction materials:</b>	
<ul style="list-style-type: none"> <li><b>Body, cap, cover</b> - zinc alloy</li> <li><b>Head</b> - brass</li> <li><b>Valve plug</b> - plastic</li> <li><b>Seals</b> - oil resistant rubber</li> <li><b>Caps</b> - aluminium alloy</li> </ul>	
<b>Connection thread:</b> G3/8; G1/2; G3/4	

Please note: other material versions (e.g. stainless steel, acid-resistant steel, brass) available after technical consultation.



### DIMENSIONS

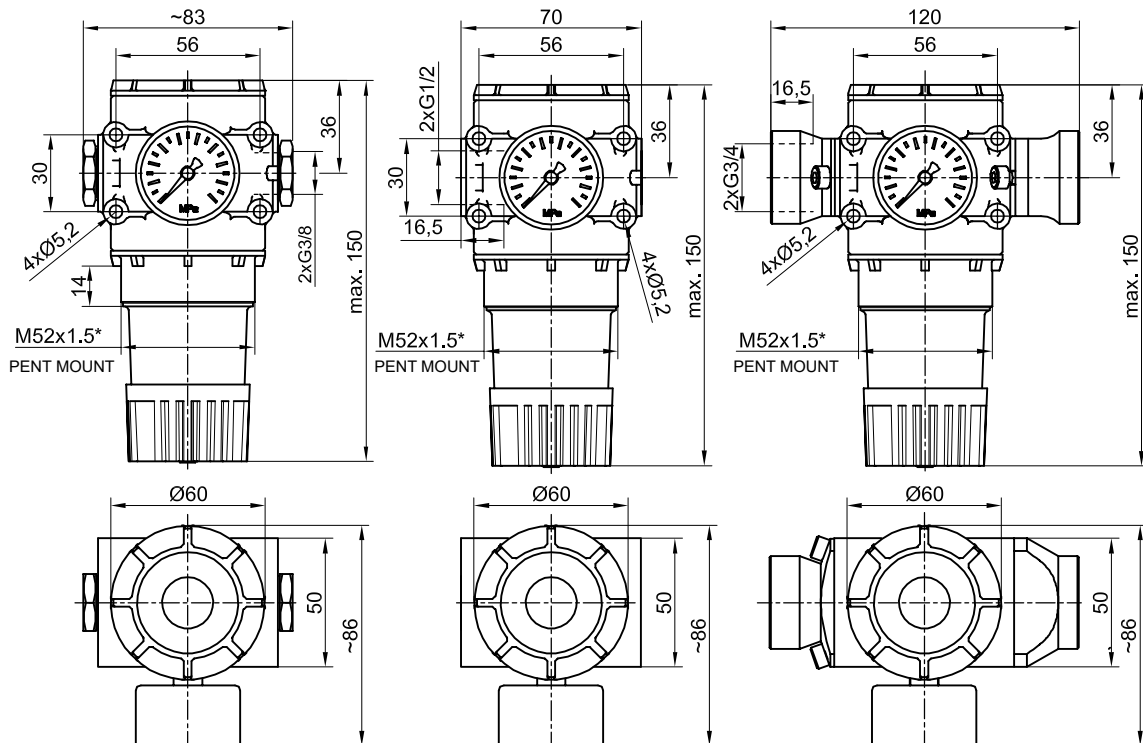

G3/8 reducing valve

\* pent mounting thread on special order

G1/2 reducing valve

G3/4 reducing valve

### ORDER NUMBERS

Connection thread	Outlet pressure range [MPa]	Nominal flow [6 bar]	Order number standard	Order number for the pent valve	Order number for the pent mount nut
G3/8	0.05 — 0.30	3,120 l/min	50.1101.3403	<b>50.1101.3803MP</b>	<b>59.1101.15</b>
	0.05 — 0.70		50.1101.3407	<b>50.1101.3807MP</b>	
	0.05 — 1.20		50.1101.3412	<b>50.1101.3812MP</b>	
G1/2	0.05 — 0.30	4,060 l/min	50.1101.1203	<b>50.1101.1203MP</b>	
	0.05 — 0.70		50.1101.1207	<b>50.1101.1207MP</b>	
	0.05 — 1.20		50.1101.1212	<b>50.1101.1212MP</b>	
G3/4	0.05 — 0.30	4,060 l/min	50.1101.3403	<b>50.1101.3403MP</b>	
	0.05 — 0.70		50.1101.3407	<b>50.1101.3407MP</b>	
	0.05 — 1.20		50.1101.3412	<b>50.1101.3412MP</b>	

### FLOW AND CONTROL CHARACTERISTICS

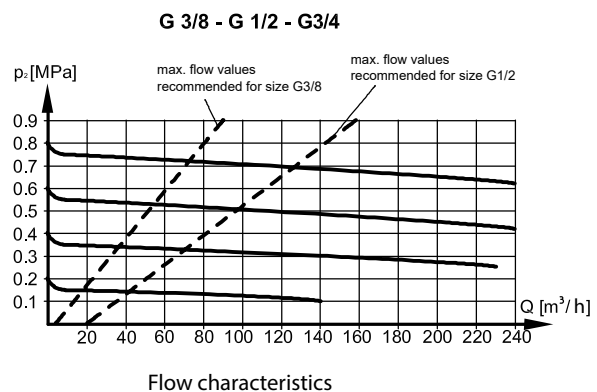
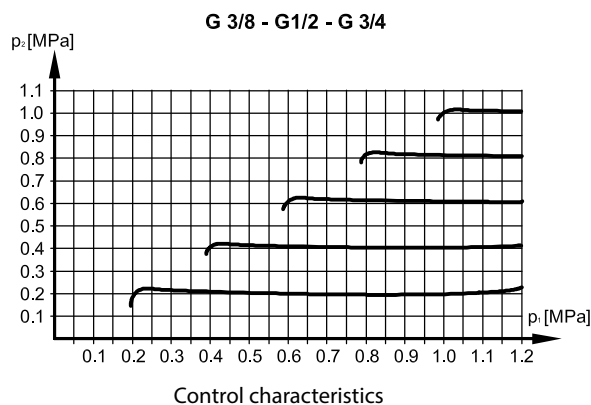

### ORDERING PROCEDURE

In your order, please specify: the name, connection thread, order number and number of pieces, e.g.:  
**CLASSIC G1/2 reducing valve, no. 50.1101.1212 1 pc.**

### ADDITIONAL ELEMENTS:

Fasteners for CLASSIC reducing valve	page 9.11.01.01-02
Repair kits for CLASSIC reducing valve	page 9.12.04

## TECHNICAL SPECIFICATIONS

<b>Maximum inlet pressure:</b>	16 bar	
<b>Medium:</b>	Compressed air or other technical gas neutral to the structural materials used	
<b>Operating temperature range:</b>	0 to + 65°C	
<b>Outlet pressure range:</b>	0.5—3.0; 0.5—7.0; 0.5—12.0 bar	
<b>Operating position:</b>	any position	
<b>Construction materials:</b>		
<b>Body</b> - aluminium alloy <b>Body cover</b> - plastic <b>Cap, cover</b> - plastic <b>Head</b> - brass <b>Seals</b> - oil resistant rubber		
<b>Connection thread:</b>	G3/8; G1/2	



## DIMENSIONS

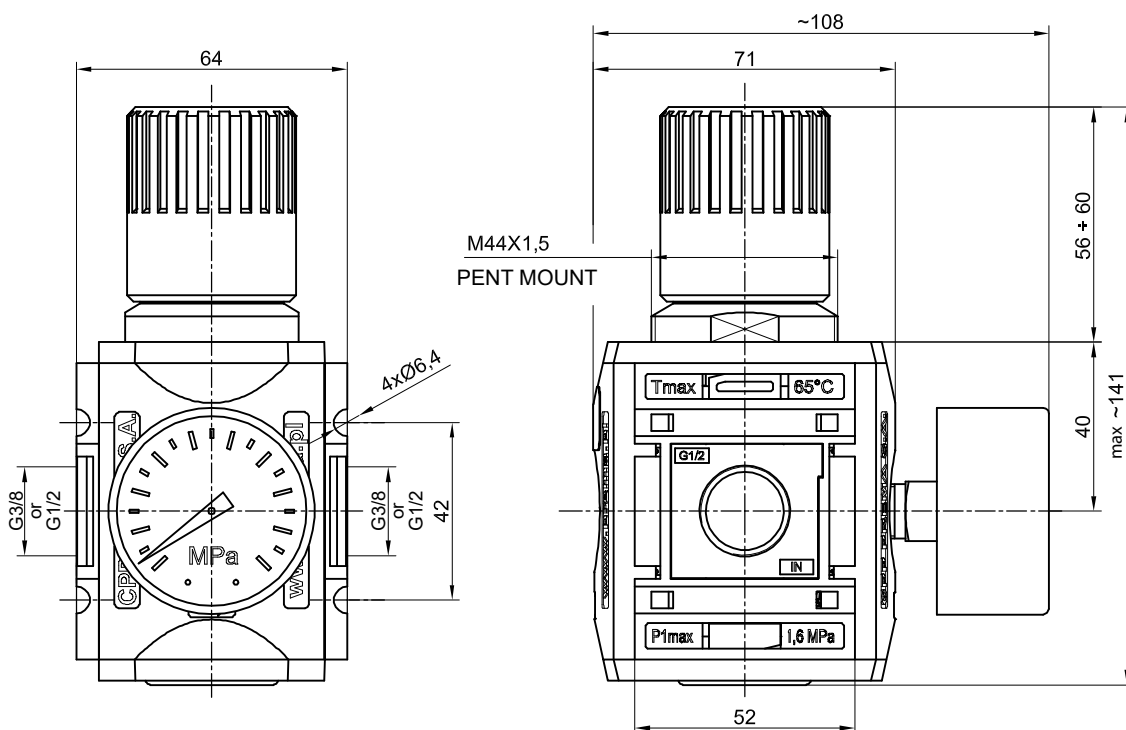

### FLOW CHARACTERISTICS

G1/2 Pressure-reducing valve (fully open position) - inlet pressure  $p_1 = 6.3$  bar

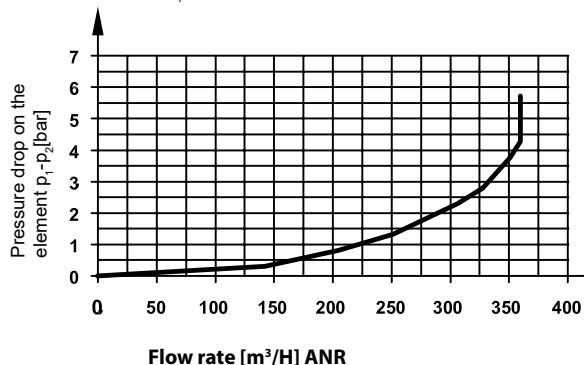
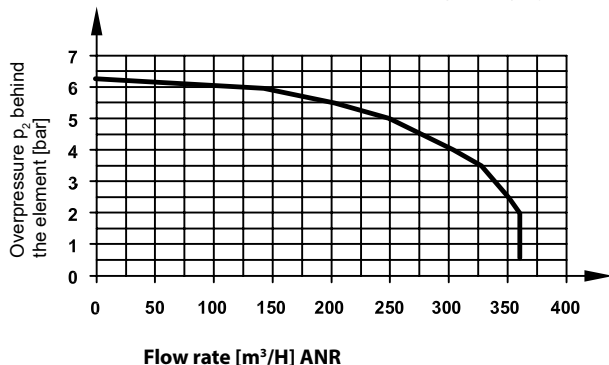

### ORDER NUMBERS

Connection thread	Outlet pressure range [MPa]	Nominal flow [6 bar]	Order number	Order number for the pent mount nut
G3/8	0.05 — 0.30	3,120 l/min	50.2101.3803	59.2101.15*
	0.05 — 0.70		50.2101.3807	
	0.05 — 1.20		50.2101.3812	
G1/2	0.05 — 0.30	4,060 l/min	50.2101.1203	
	0.05 — 0.70		50.2101.1207	
	0.05 — 1.20		50.2101.1212	

### ORDERING PROCEDURE

In your order, please specify: the name, connection thread, order number and number of pieces, e.g.:  
**NOVA G1/2 reducing valve, no. 50.2101.1212 1 pc.**

### ADDITIONAL ELEMENTS:

Fasteners for NOVA reducing valve	page 9.11.02.01-02
Repair kits for NOVA reducing valve	page 9.12.06

\* For a technical drawing of the nut see page 9.11.02.01

### TECHNICAL SPECIFICATIONS

<b>Maximum inlet pressure:</b> 16 bar	
<b>Medium:</b> Compressed air or other technical gas neutral to the structural materials used	
<b>Outlet pressure range:</b> 0.1 — 16 bar	
<b>Operating temperature range:</b> from 0°C to +60°C	
<b>Operating position:</b> any position	
<b>Construction materials:</b>	
<b>Body</b> - zinc alloy <b>Head</b> - NBR brass <b>Seals</b> - NBR	
<b>Connection thread:</b> G1; G1 1/4; G1 1/2	

### DIMENSIONS

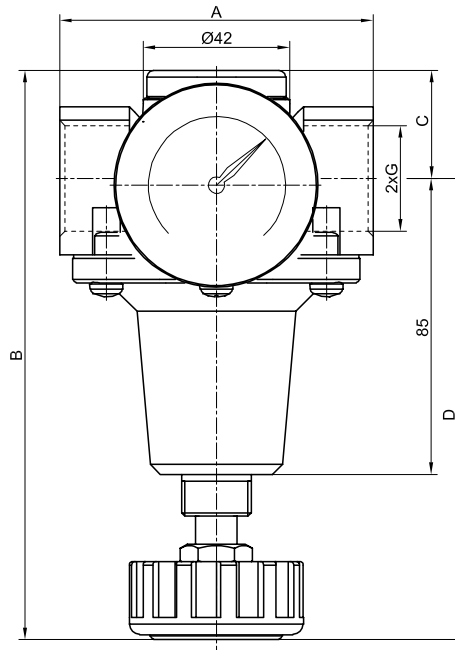

### REDUCER COMPLETE WITH PRESSURE GAUGE

Connection thread	Adjustment range	Nominal flow [6 bar]	Pressure gauge range	Dimensions				Order number
				A	B	C	D	
<b>Flow rate: 5000 l/min</b>								
G1	0.10 - 3 bar	5,000 l/min	0 - 6 bar	90	165.9	31	134.9	80.0101.100821
G1	0.50 - 6 bar		0 - 10 bar	90	165.9	31	134.9	80.0101.100822
G1	0.50 - 10 bar		0 - 16 bar	90	165.9	31	134.9	80.0101.100823
G1	0.50 - 16 bar		0 - 25 bar	90	165.9	31	134.9	80.0101.100824
<b>Flow rate: 16500 l/min</b>								
G1 1/4	0.50 - 3 bar	16,500 l/min	0 - 6 bar	125	255	52	203	80.0101.100825
G1 1/4	0.50 - 10 bar		0 - 16 bar	125	255	52	203	80.0101.100826
G1 1/4	0.50 - 16 bar		0 - 25 bar	125	255	52	203	80.0101.100827
G1 1/2	0.50 - 3 bar	16,500 l/min	0 - 6 bar	125	255	52	203	80.0101.100828
G1 1/2	0.50 - 10 bar		0 - 16 bar	125	255	52	203	80.0101.100829
G1 1/2	0.50 - 16 bar		0 - 25 bar	125	255	52	203	80.0101.100830

### REDUCER WITHOUT PRESSURE GAUGE

Connection thread	Adjustment range	Nominal flow [6 bar]	Dimensions				Order number
			A	B	C	D	
<b>Flow rate: 5000 l/min</b>							
<b>G1</b>	0.10 - 3 bar	5,000 l/min	125	255	52	203	<b>80.0101.100865</b>
<b>G1</b>	0.50 - 6 bar		125	255	52	203	<b>80.0101.100866</b>
<b>G1</b>	0.50 - 10 bar		125	255	52	203	<b>80.0101.100867</b>
<b>G1</b>	0.50 - 16 bar		125	255	52	203	<b>80.0101.100868</b>

### ORDERING PROCEDURE

In your order, please specify: the name, connection thread, order number and number of pieces, e.g.:  
**Reducing valve MAXI G1, no. 80.0101.100867 1 pc.**

### TECHNICAL SPECIFICATIONS

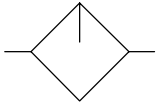
<b>Maximum inlet pressure:</b>	12 bar	
<b>Medium:</b>	Compressed air or other technical gas neutral to the structural materials used	
<b>Operating temperature range:</b>	0 to + 65°C	
<b>Operating position:</b>	vertical, tank down	
<b>Lubricator drip start:</b>	1m <sup>3</sup> /h	
<b>Recommended oil:</b>	mineral oil free from water and acids, with a viscosity of 2-4°E/50°C	
<b>Construction materials:</b>		
<b>Body</b> - aluminium alloy <b>Tank, dome</b> - transparent polycarbonate <b>Nozzles, suction pipe</b> - plastic <b>Seals, diaphragm</b> - oil resistant rubber		
<b>Connection thread:</b>	G1/8; G1/4	

Please note: other material versions (e.g. stainless steel, acid-resistant steel, brass) available after technical consultation.



### DIMENSIONS

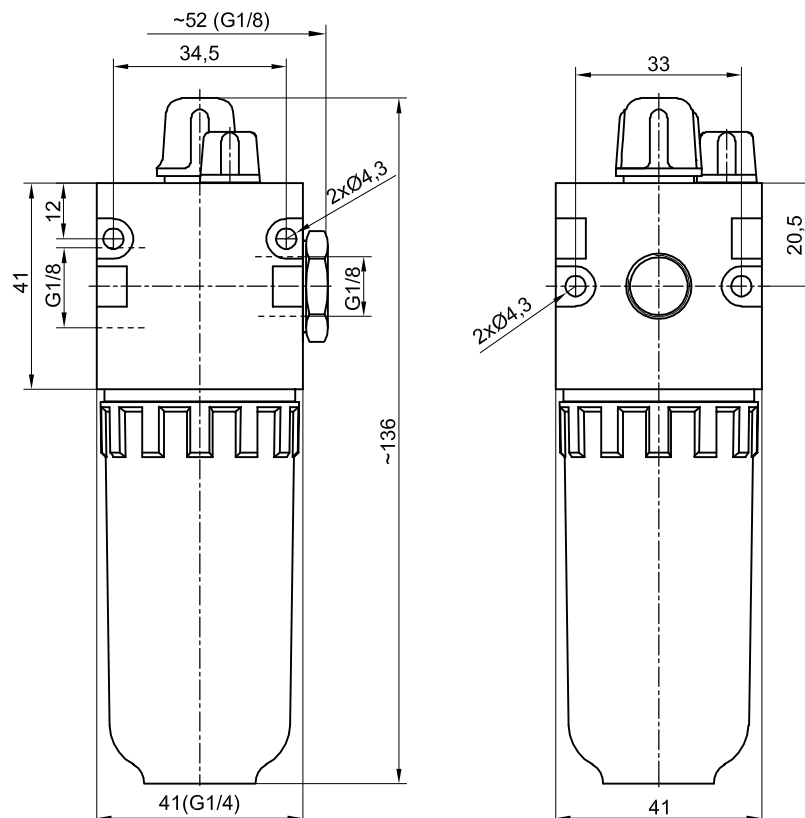

Please note: The G1/8 connection thread is obtained by screwing a R1/4 x G1/8 reducer screw plug into the connection threads



### FLOW CHARACTERISTICS

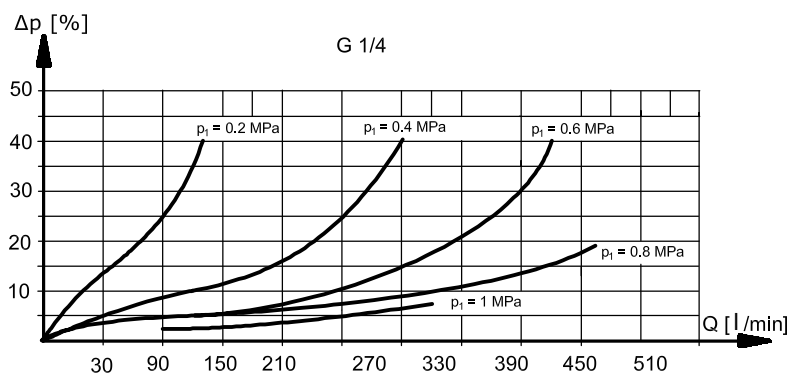

### ORDER NUMBERS

Connection thread	Nominal flow [6 bar]	Order number
G1/8	690 l/min	50.0301.18
G1/4	1,560 l/min	50.0301.14

### ORDERING PROCEDURE

In your order, please specify: the name, connection thread, order number and number of pieces, e.g.:  
**MINI G1/4 compressed air lubricator, no. 50.0301.14 1 pc.**

### ADDITIONAL ELEMENTS:

Fasteners for MINI compressed air lubricator	page 9.11.01.01-02
Repair kits for MINI compressed air lubricator	page 9.12.11

### TECHNICAL SPECIFICATIONS

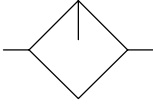
<b>Maximum inlet pressure:</b>	12 bar	
<b>Medium:</b>	Compressed air or other technical gas neutral to the structural materials used	
<b>Operating temperature range:</b>	0 to + 65°C	
<b>Operating position:</b>	vertical, tank down	
<b>Lubricator drip start:</b>	3m <sup>3</sup> /h	
<b>Recommended oil:</b>	mineral oil free from water and acids, with a viscosity of 2-4°E/50°C	
<b>Construction materials:</b>		
<b>Body</b>	- zinc alloy	
<b>Tank, dome</b>	- transparent polycarbonate	
<b>Nozzles, suction pipe</b>	- plastic	
<b>Seals, diaphragm</b>	- oil resistant rubber	
<b>Caps</b>	- aluminium alloy	
<b>Connection thread:</b>	G3/8; G1/2; G3/4	

Please note: other material versions (e.g. stainless steel, acid-resistant steel, brass) available after technical consultation.



### DIMENSIONS

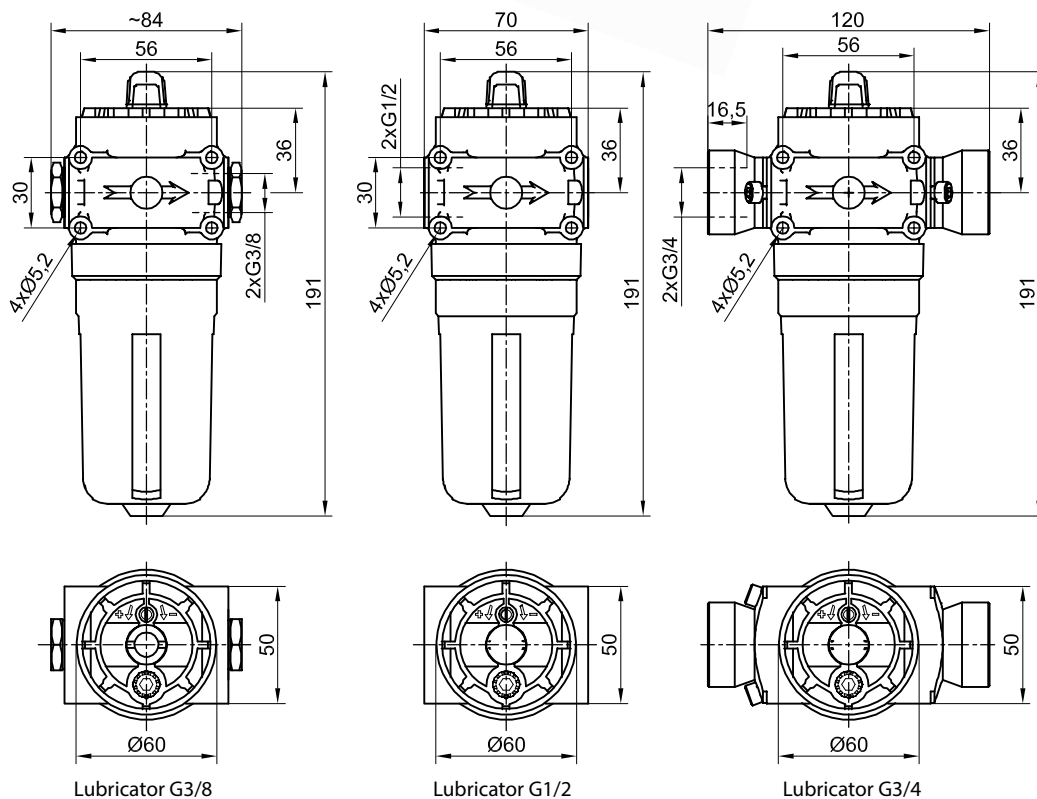

### FLOW CHARACTERISTICS

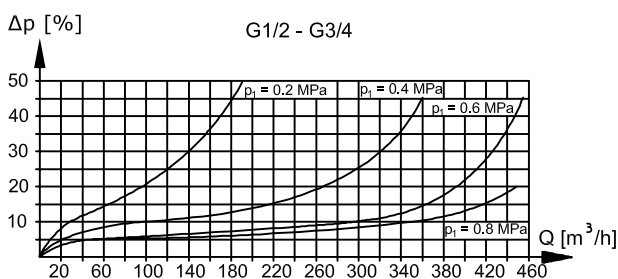
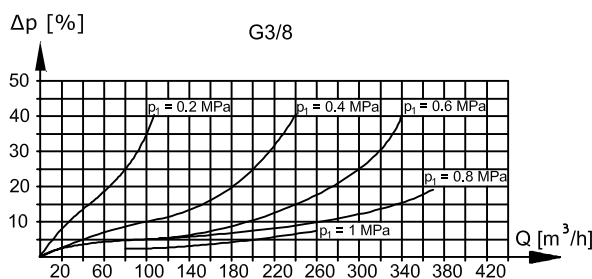

### ORDER NUMBERS

Connection thread	Nominal flow [6 bar]	Order number
G3/8	2,500 l/min	50.1301.38
G1/2	4,200 l/min	50.1301.12
G3/4	4,200 l/min	50.1301.34

### ORDERING PROCEDURE

In your order, please specify: the name, connection thread, order number and number of pieces, e.g.:  
**CLASSIC G1/2 compressed air lubricator, no. 50.1301.12 1 pc.**

### ADDITIONAL ELEMENTS:

Fasteners for CLASSIC compressed air lubricator	page 9.11.01.01-02
Repair kits for CLASSIC compressed air lubricator	page 9.12.10

### TECHNICAL SPECIFICATIONS

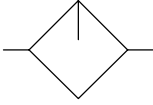
<b>Maximum inlet pressure:</b>	16 bar	
<b>Medium:</b>	Compressed air or other technical gas neutral to the structural materials used	
<b>Operating temperature range:</b>	0 to + 65°C	
<b>Operating position:</b>	vertical, tank down	
<b>Lubricator drip start:</b>	3m <sup>3</sup> /h	
<b>Recommended oil:</b>	mineral oil free from water and acids, with a viscosity of 2-4°E/50°C	
<b>Construction materials:</b>		
<b>Body</b>	- aluminium alloy	
<b>Tank, domes</b>	- transparent polycarbonate	
<b>Tank cover</b>	- plastic	
<b>Body cover</b>	- plastic	
<b>Filter cartridge</b>	- polyethylene composite or bronze sinter	
<b>Seals</b>	- oil resistant rubber	
<b>Connection thread:</b>	G3/8; G1/2	



### DIMENSIONS

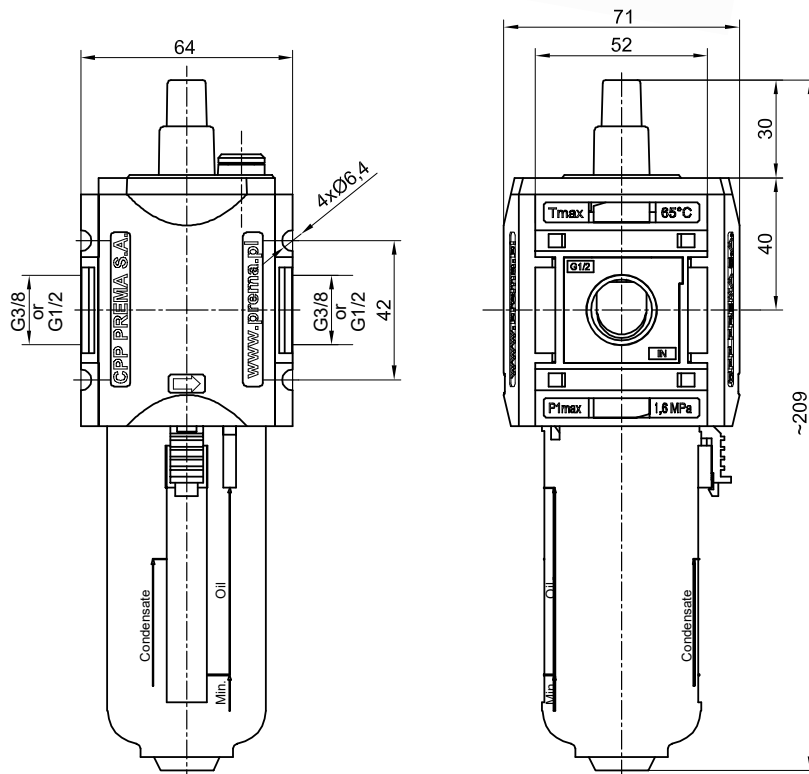

### FLOW CHARACTERISTICS

Compressed air lubricator G1/2 (without dripping) - inlet pressure  $p_1 = 6.3$  bar

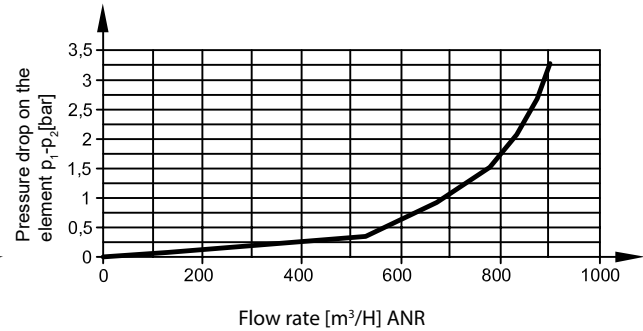
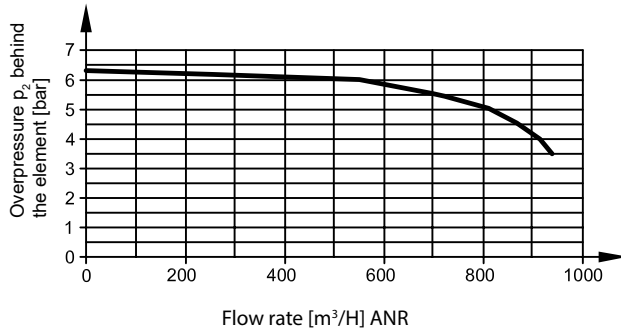

### ORDER NUMBERS

Connection thread	Nominal flow [6 bar]	Order number
G3/8	2,500 l/min	50.2301.38
G1/2	4,200 l/min	50.2301.12

### ORDERING PROCEDURE

In your order, please specify: the name, connection thread, order number and number of pieces, e.g.:  
**NOVA G1/2 compressed air lubricator, no. 50.2301.12 1 pc.**

### ADDITIONAL ELEMENTS:

Fasteners for NOVA compressed air lubricator	page 9.11.02.01-02
Repair kits for NOVA compressed air lubricator	page 9.12.12

### TECHNICAL SPECIFICATIONS

<b>Outlet pressure range:</b> 0.5 – 16 bar	
<b>Medium:</b> Compressed air or other technical gas neutral to the structural materials used	
<b>Operating temperature range:</b> 0 to + 60°C	
<b>Recommended oil:</b> mineral oil free of water and acids	
<b>Construction materials:</b> <b>Body</b> zinc alloy <b>Tank</b> Polycarbonate <b>Seals</b> NBR	
<b>Connection thread:</b> G1; G1 1/4; G1 1/2	

### DIMENSIONS

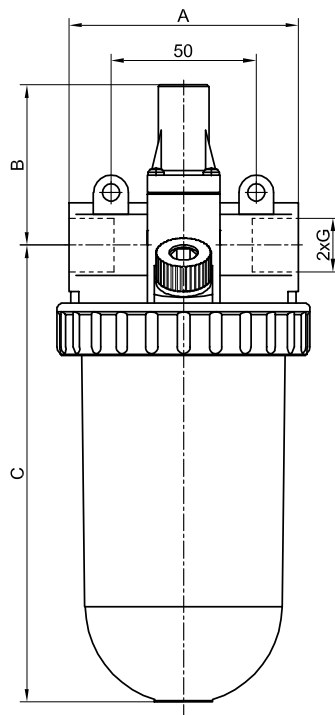

### ORDER NUMBERS

Connection thread	Tank material	Nominal flow [6 bar]	A	C	D	Order number
G1	plastic	9,000 l/min	90	58	160	80.0301.101019
	metal	9,000 l/min	90	58	160	80.0301.101035
	plastic with metal cover	9,000 l/min	90	58	160	80.0301.101027
G1 1/4	plastic	9,000 l/min	137	70	232	80.0301.101020
	metal	9,000 l/min	137	70	232	80.0301.101036
	plastic with metal cover	9,000 l/min	137	70	232	80.0301.101028
G1 1/2	plastic	9,000 l/min	125	70	232	80.0301.101021
	metal	9,000 l/min	125	70	232	80.0301.101037
	plastic with metal cover	9,000 l/min	125	70	232	80.0301.101029

### ORDERING PROCEDURE

In your order, please specify: the name, connection thread, order number and number of pieces, e.g.:  
**Compressed air lubricator MAXI G1 no. 80.0301.101019 1 pc.**



### TECHNICAL SPECIFICATIONS

<b>Maximum inlet pressure:</b>	12 bar	
<b>Medium:</b>	Compressed air or other technical gas neutral to the structural materials used	
<b>Outlet pressure range:</b>	0.5—3.0; 0.5—7.0; 0.5—10.0 bar	
<b>Operating temperature range:</b>	0 to + 65°C	
<b>Operating position:</b>	vertical, tank down	
<b>Construction materials:</b>		
<b>Body, cap</b>	- aluminium alloy	
<b>Head</b>	- brass	
<b>Tank</b>	- transparent polycarbonate	
<b>Filter cartridge</b>	- bronze sinter	
<b>Wheel, cover, hood</b>	- plastic	
<b>Seals, diaphragm</b>	- oil resistant rubber	
<b>Connection thread:</b>	G 1/8; G1/4	

Please note: other material versions (e.g. stainless steel, acid-resistant steel, brass) available after technical consultation.



### DIMENSIONS

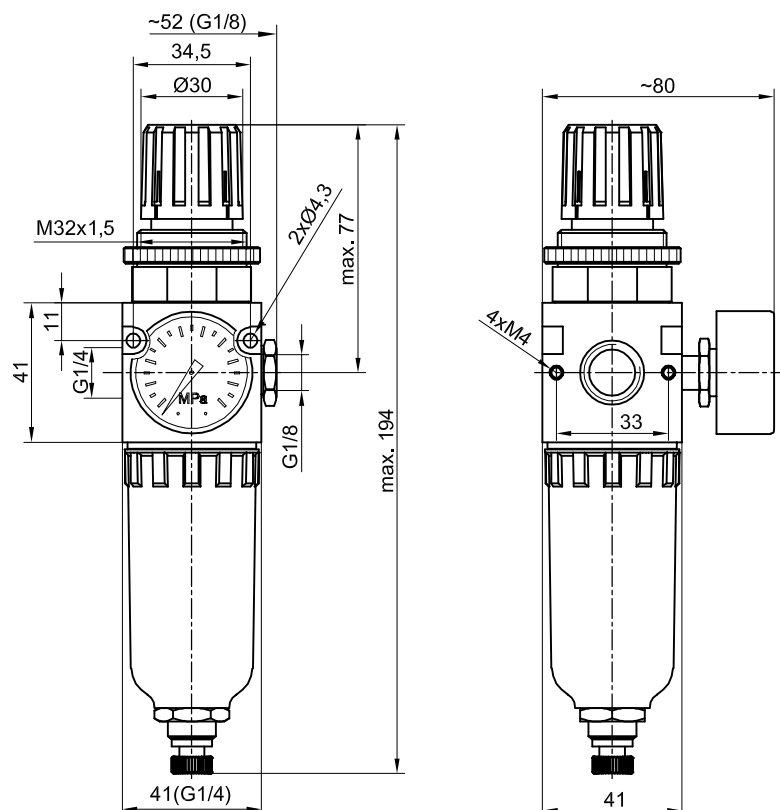

**Please note:** The G 1/8 connection thread is obtained by screwing a R1/4 x G1/8 reducer screw plug into the connection threads



### FLOW AND CONTROL CHARACTERISTICS

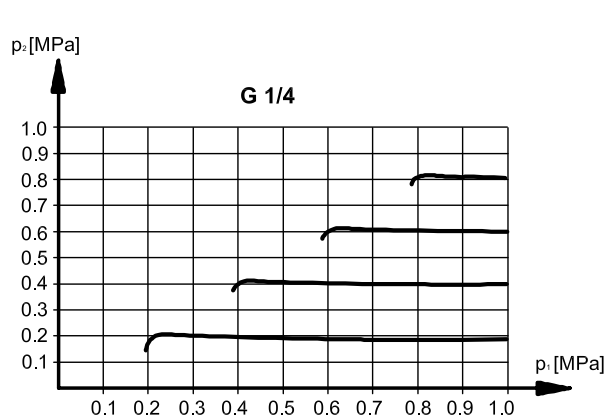

Control characteristics

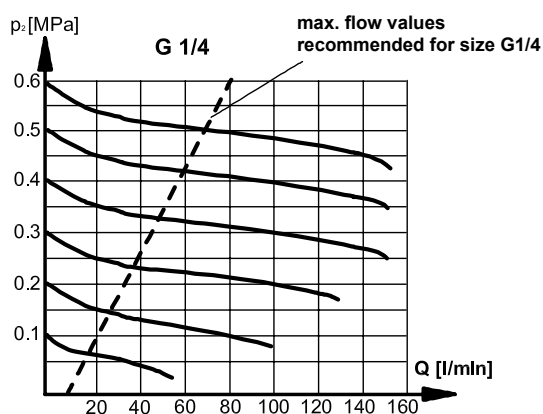

Flow characteristics

### ORDER NUMBERS

Connection thread	Outlet pressure range [MPa]	Micron rating [ $\mu\text{m}$ ]	Nominal flow [6 bar]	Order number
G1/8	0.05 — 0.30	5	810 l/min	50.0201.1803.05
	0.05 — 0.70			50.0201.1807.05
	0.05 — 1.00			50.0201.1810.05
	0.05 — 0.30	10		50.0201.1803.10
	0.05 — 0.70			50.0201.1807.10
	0.05 — 1.00			50.0201.1810.10
	0.05 — 0.30	40		50.0201.1803.40
	0.05 — 0.70			50.0201.1807.40
0.05 — 1.00	50.0201.1810.40			
G1/4	0.05 — 0.30	5	2,130 l/min	50.0201.1403.05
	0.05 — 0.70			50.0201.1407.05
	0.05 — 1.00			50.0201.1410.05
	0.05 — 0.30	10		50.0201.1403.10
	0.05 — 0.70			50.0201.1407.10
	0.05 — 1.00			50.0201.1410.10
	0.05 — 0.30	40		50.0201.1403.40
	0.05 — 0.70			50.0201.1407.40
	0.05 — 1.00			50.0201.1410.40

### ORDERING PROCEDURE

In your order, please specify: the name, connection thread, order number and number of pieces, e.g.:  
**MINI G1/4 filtering and reduction unit, no. 50.0201.1410.10 1 pc.**

### ADDITIONAL ELEMENTS:

Fasteners for MINI filtering and reduction unit	page 9.11.01.01-02
Repair kits for MINI filtering and reduction unit	page 9.12.08

### TECHNICAL SPECIFICATIONS

<b>Maximum inlet pressure:</b>	12 bar	
<b>Medium:</b>	Compressed air or other technical gas neutral to the structural materials used	
<b>Outlet pressure range:</b>	0.5—3.0; 0.5—7.0; 0.5—12.0 bar	
<b>Operating temperature range:</b>	0 to + 65°C	
<b>Operating position:</b>	vertical, tank down	
<b>Construction materials:</b>		
<b>Body, cap</b> - zinc alloy <b>Head</b> - brass <b>Tank</b> - transparent polycarbonate <b>Filter cartridge</b> - bronze sinter <b>Piston, wheel, cover, hood</b> - plastic <b>Seals</b> - oil resistant rubber		
<b>Connection thread:</b>	G3/8; G1/2; G3/4	

Please note: other material versions (e.g. stainless steel, acid-resistant steel, brass) available after technical consultation.



### DIMENSIONS

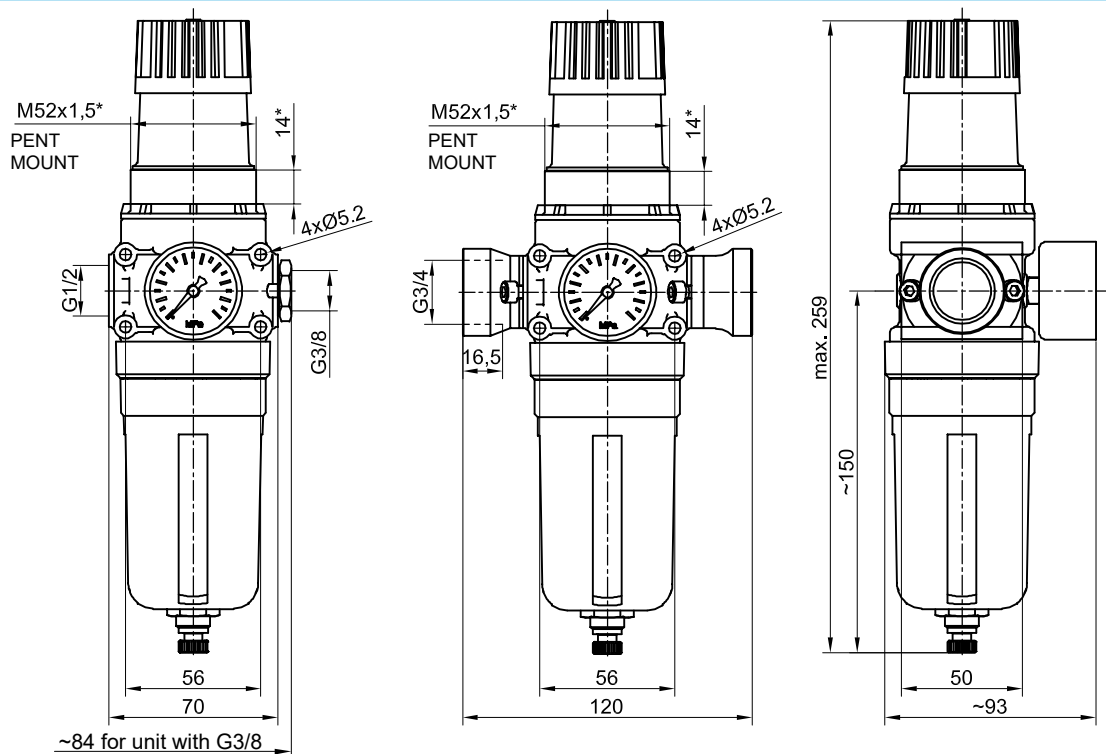

Filtration and reduction unit G3/8-G1/2

Filtration and reduction unit G3/4

\* pent mounting thread on special order

### FLOW AND CONTROL CHARACTERISTICS

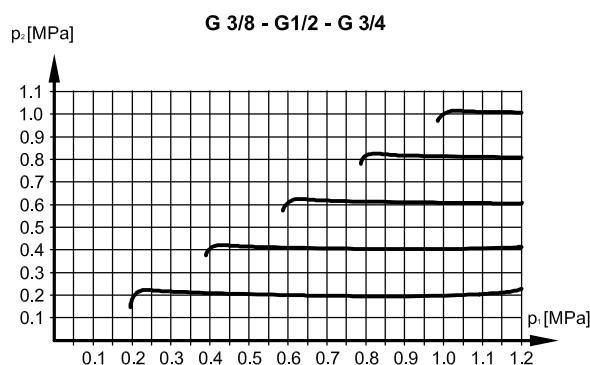

Control characteristics

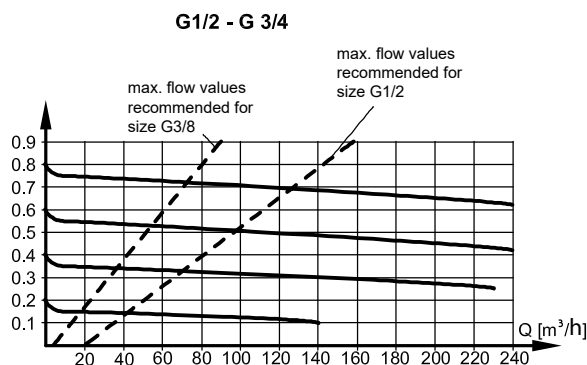

Flow characteristics

### ORDER NUMBERS

Con- nection thread	Outlet pressure range [MPa]	Micron rating [ $\mu$ m]	Nominal flow [6 bar]	Order number standard		Order number for the pent mounting unit	
				Manual drain	Automatic drain	Manual drain	Automatic drain
G3/8	0.05 — 0.30	5	2,750 l/min	50.1201.3803.05	50.1211.3803.05	58.1201.3803.05	58.1211.3803.05
				50.1201.3807.05	50.1211.3807.05	58.1201.3807.05	58.1211.3807.05
	50.1201.3812.05			50.1211.3812.05	58.1201.3812.05	58.1211.3812.05	
	50.1201.3803.10			50.1211.3803.10	58.1201.3803.10	58.1211.3803.10	
	0.05 — 0.70	10		50.1201.3807.10	50.1211.3807.10	58.1201.3807.10	58.1211.3807.10
				50.1201.3812.10	50.1211.3812.10	58.1201.3812.10	58.1211.3812.10
	0.05 — 1.20	40		50.1201.3803.40	50.1211.3803.40	58.1201.3803.40	58.1211.3803.40
				50.1201.3807.40	50.1211.3807.40	58.1201.3807.40	58.1211.3807.40
G1/2	0.05 — 0.30	5	3,860 l/min	50.1201.1203.05	50.1211.1203.05	58.1201.1203.05	58.1211.1203.05
				50.1201.1207.05	50.1211.1207.05	58.1201.1207.05	58.1211.1207.05
	50.1201.1212.05			50.1211.1212.05	58.1201.1212.05	58.1211.1212.05	
	50.1201.1203.10			50.1211.1203.10	58.1201.1203.10	58.1211.1203.10	
	0.05 — 0.70	10		50.1201.1207.10	50.1211.1207.10	58.1201.1207.10	58.1211.1207.10
				50.1201.1212.10	50.1211.1212.10	58.1201.1212.10	58.1211.1212.10
	0.05 — 1.20	40		50.1201.1203.40	50.1211.1203.40	58.1201.1203.40	58.1211.1203.40
				50.1201.1207.40	50.1211.1207.40	58.1201.1207.40	58.1211.1207.40
G3/4	0.05 — 0.30	5	3,860 l/min	50.1201.1212.40	50.1211.1212.40	58.1201.1212.40	58.1211.1212.40
				50.1201.3403.05	50.1211.3403.05	58.1201.3403.05	58.1211.3403.05
	50.1201.3407.05			50.1211.3407.05	58.1201.3407.05	58.1211.3407.05	
	50.1201.3412.05			50.1211.3412.05	58.1201.3412.05	58.1211.3412.05	
	0.05 — 0.70	10		50.1201.3403.10	50.1211.3403.10	58.1201.3403.10	58.1211.3403.10
				50.1201.3407.10	50.1211.3407.10	58.1201.3407.10	58.1211.3407.10
	0.05 — 1.20	40		50.1201.3412.10	50.1211.3412.10	58.1201.3412.10	58.1211.3412.10
				50.1201.3403.40	50.1211.3403.40	58.1201.3403.40	58.1211.3403.40
0.05 — 0.70	40	50.1201.3407.40	50.1211.3407.40	58.1201.3407.40	58.1211.3407.40		
		50.1201.3412.40	50.1211.3412.40	58.1201.3412.40	58.1211.3412.40		
Nut for pent mounting				59.1101.15			

### ORDERING PROCEDURE

In your order, please specify: the name, connection thread, order number and number of pieces, e.g.:  
**CLASSIC G3/4 filtering and reduction unit, no. 50.1201.3407.10 1 pc.**

### ADDITIONAL ELEMENTS:

Fasteners for CLASSIC filtering and reduction unit	page 9.11.01.01.01-02
Repair kits for CLASSIC filtering and reduction unit	page 9.12.07

### TECHNICAL SPECIFICATIONS

<b>Maximum inlet pressure:</b>	16 bar
<b>Medium:</b>	Compressed air or other technical gas neutral to the structural materials used
<b>Outlet pressure range:</b>	0.5—3.0; 0.5—7.0; 0.5—12.0 bar
<b>Operating temperature range:</b>	0 to +65°C
<b>Operating position:</b>	vertical, tank down
<b>Construction materials:</b>	
<b>Body</b>	- aluminium alloy
<b>Tank</b>	- transparent polycarbonate
<b>Cap, cover</b>	- plastic
<b>Body cover</b>	- plastic
<b>Filter cartridge</b>	- polyethylene composite or bronze sinter
<b>Seals</b>	- oil resistant rubber
<b>Connection thread:</b>	G3/8 - G1/2

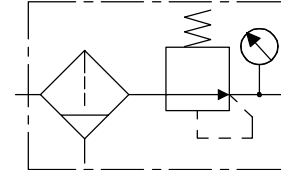

### DIMENSIONS

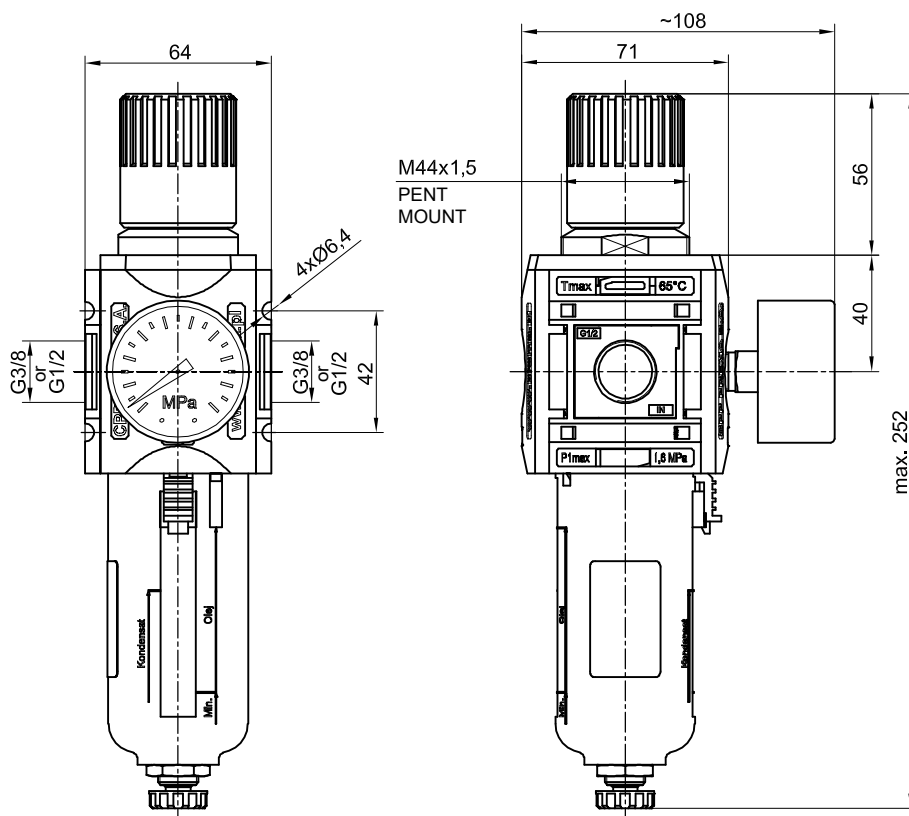

### FLOW CHARACTERISTICS

Filter and reduction unit (fully open valve, insert 40 μm) - inlet pressure  $p_1 = 6.3$  bar

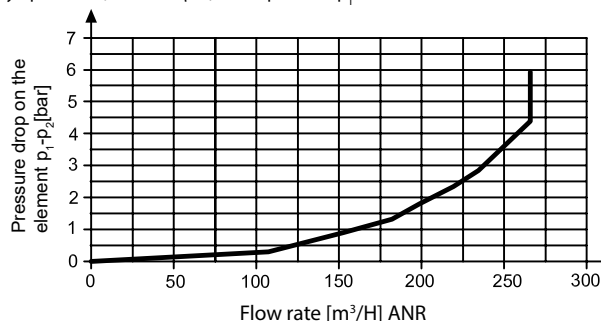
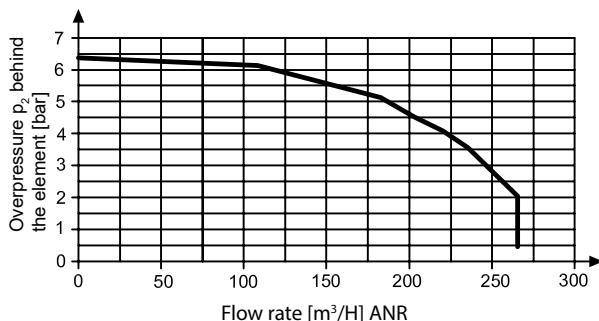

### ORDER NUMBERS

Connection thread	Outlet pressure range [MPa]	Micron rating [μm]	Nominal flow [6 bar]	Order number
G3/8	0.05 — 0.30	5	2,750 l/min	50.2201.3803.05
	0.05 — 0.70			50.2201.3807.05
	0.05 — 1.20			50.2201.3812.05
	0.05 — 0.30	10		50.2201.3803.10
	0.05 — 0.70			50.2201.3807.10
	0.05 — 1.20			50.2201.3812.10
	0.05 — 0.30	40		50.2201.3803.40
	0.05 — 0.70			50.2201.3807.40
0.05 — 1.20	50.2201.3812.40			
G1/2	0.05 — 0.30	5	3,860 l/min	50.2201.1203.05
	0.05 — 0.70			50.2201.1207.05
	0.05 — 1.20			50.2201.1212.05
	0.05 — 0.30	10		50.2201.1203.10
	0.05 — 0.70			50.2201.1207.10
	0.05 — 1.20			50.2201.1212.10
	0.05 — 0.30	40		50.2201.1203.40
	0.05 — 0.70			50.2201.1207.40
	0.05 — 1.20			50.2201.1212.40

### ORDERING PROCEDURE

In your order, please specify: the name, connection thread, order number and number of pieces, e.g.:  
**NOVA G3/8 filtering and reduction unit, no. 50.2201.3812.10 1 pc.**

### ADDITIONAL ELEMENTS:

Fasteners for NOVA filtering and reduction unit	page 9.11.02.01-02
Repair kits for NOVA filtering and reduction unit	page 9.12.09

### TECHNICAL SPECIFICATIONS

<b>Maximum inlet pressure:</b>	16 bar
<b>Medium:</b>	Compressed air or other technical gas neutral to the structural materials used
<b>Outlet pressure range:</b>	0.5 – 16 bar
<b>Operating temperature range:</b>	0 to + 60°C
<b>Operating position:</b>	vertical, tank down
<b>Construction materials:</b>	
<b>Body</b>	- aluminium
<b>Head</b>	- NBR brass
<b>Seals</b>	- NBR
<b>Membrane</b>	- NBR brass
<b>Connection thread:</b>	G1

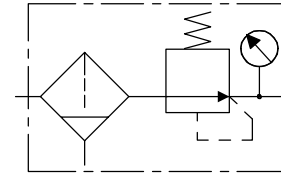

### DIMENSIONS

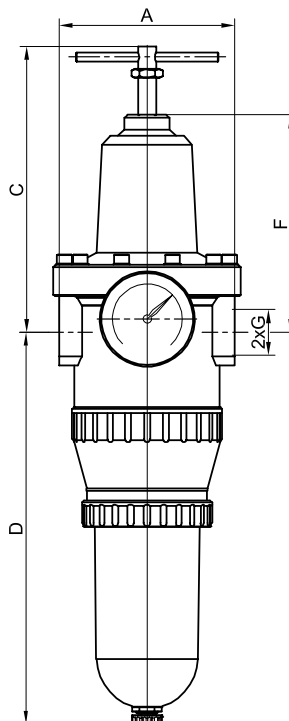

### REDUCER COMPLETE WITH PRESSURE GAUGE

Con- nection thread	Tank material	Adjustment range	Pressure gauge range	Nominal flow [6bar]	A	C	D	F	Order number
<b>Flow rate: 4000 l/min, Micron rating: 40 µm</b>									
<b>G1</b>	plastic	0 - 16 bar	1 - 16 bar	7,000 l/min	125	190.6	261.4	145	<b>80.0201.100927</b>
	metal	0 - 16 bar	0.5 - 16 bar		125	190.6	261.4	145	<b>80.0201.100939</b>
	plastic with metal cover	0 - 16 bar	1 - 16 bar		125	190.6	261.4	145	<b>80.0201.100933</b>

### ORDERING PROCEDURE

In your order, please specify: the name, connection thread, order number and number of pieces, e.g.:  
**Filtering and reduction valve MAXI G1, no. 80.0201.100927 1 pc.**







# MINI SERIES

Compressed air preparation block  
two elements (filtering and reduction unit, lubricator)



## ORDER NUMBERS

Connection thread	Outlet pressure range [MPa]	Micron rating [ $\mu\text{m}$ ]	Order number
G1/8	0.05 — 0.30	5	50.0502.1803.05
	0.10 — 0.70		50.0502.1807.05
	0.10 — 1.0		50.0502.1810.05
	0.05 — 0.30	10	50.0502.1803.10
	0.10 — 0.70		50.0502.1807.10
	0.10 — 1.0		50.0502.1810.10
	0.05 — 0.30	40	50.0503.1803.40
	0.10 — 0.70		50.0502.1807.40
	0.10 — 1.0		50.0502.1810.40
G1/4	0.05 — 0.30	5	50.0502.1403.05
	0.10 — 0.70		50.0502.1407.05
	0.10 — 1.0		50.0502.1410.05
	0.05 — 0.30	10	50.0502.1403.10
	0.10 — 0.70		50.0502.1407.10
	0.10 — 1.0		50.0502.1410.10
	0.05 — 0.30	40	50.0503.1403.40
	0.10 — 0.70		50.0502.1407.40
	0.10 — 1.0		50.0502.1410.40

## ORDERING PROCEDURE

In your order, please specify: the name, connection thread, order number and number of pieces, e.g.:  
**Compressed air preparation block, two-element NOVA G1/2, no. 50.0502.1407.40 1 pc.**

## ADDITIONAL ELEMENTS:

Fasteners for MINI compressed air preparation block	page 9.11.01.01-02
Repair kits for MINI compressed air preparation block	page: filtering and reduction unit 9.12.08 lubricator 9.12.11

### TECHNICAL SPECIFICATIONS

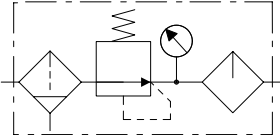
<b>Maximum inlet pressure:</b>	12 bar	
<b>Medium:</b>	Compressed air or other technical gas neutral to the structural materials used	
<b>Outlet pressure range:</b>	0.5—3.0; 0.5—7.0; 0.5—12.0 bar	
<b>Operating temperature range:</b>	0 to + 65°C	
<b>Operating position:</b>	vertical, tanks down	
<b>Lubricator drip start:</b>	3m <sup>3</sup> /h	
<b>Recommended oil:</b>	mineral oil free from water and acids, with a viscosity of 2-4°E/50°C	
<b>Construction materials:</b>		
<b>Bodies</b>	- zinc alloy	
<b>Tanks</b>	- transparent polycarbonate	
<b>Filter cartridge</b>	- bronze sinter	
<b>Wheel</b>	- plastic	
<b>Seals</b>	- oil resistant rubber (NBR)	
<b>Connection thread:</b>	G3/8; G1/2; G3/4	



### DIMENSIONS

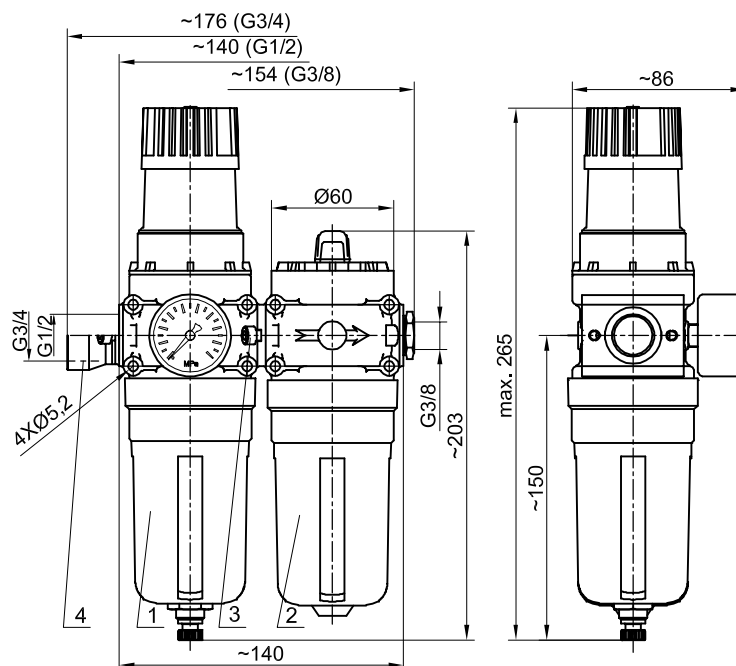

The components of the two-element compressed air preparation block G1/2, G3/4, G3/8 are:

1) filtering and reduction unit, 2) compressed air lubricator, 3) connection screws, 4) reduction screw plugs (for G3/8, G3/4).

Please note: The G3/8 connection thread is obtained by screwing a R1/2 x G3/8 reducer screw plug into the connection threads

# CLASSIC SERIES

Compressed air preparation block  
two elements (filtering and reduction unit, lubricator)



## ORDER NUMBERS

Connection thread	Outlet pressure range [MPa]	Micron rating [ $\mu\text{m}$ ]	Order number
G3/8	0.05 — 0.30	5	50.1502.3803.05
	0.05 — 0.70		50.1502.3807.05
	0.05 — 1.20		50.1502.3812.05
	0.05 — 0.30	10	50.1502.3803.10
	0.05 — 0.70		50.1502.3807.10
	0.05 — 1.20		50.1502.3812.10
	0.05 — 0.30	40	50.1503.3803.40
	0.05 — 0.70		50.1502.3807.40
	0.05 — 1.20		50.1502.3812.40
G1/2	0.05 — 0.30	5	50.1502.1203.05
	0.05 — 0.70		50.1502.1207.05
	0.05 — 1.20		50.1502.1212.05
	0.05 — 0.30	10	50.1502.1203.10
	0.05 — 0.70		50.1502.1207.10
	0.05 — 1.20		50.1502.1212.10
	0.05 — 0.30	40	50.1503.1203.40
	0.05 — 0.70		50.1502.1207.40
	0.05 — 1.20		50.1502.1212.40
G3/4	0 — 0.30	5	50.1502.3403.05
	0 — 0.70		50.1502.3407.05
	0 — 1.20		50.1502.3412.05
	0 — 0.30	10	50.1502.3403.10
	0 — 0.70		50.1502.3407.10
	0 — 1.20		50.1502.3412.10
	0 — 0.30	40	50.1503.3403.40
	0 — 0.70		50.1502.3407.40
	0 — 1.20		50.1502.3412.40

## ORDERING PROCEDURE

In your order, please specify: the name, connection thread, order number and number of pieces, e.g.:

**Two-element CLASSIC G1/2 compressed air preparation block, no. 50.1502.1212.10 1 pc.**

## ADDITIONAL ELEMENTS:

Fasteners for CLASSIC compressed air preparation block	page 9.11.01.01.01-02
Repair kits for CLASSIC compressed air preparation block	page: filtering and reduction unit 9.12.07 lubricator 9.12.10

### TECHNICAL SPECIFICATIONS

<b>Maximum inlet pressure:</b>	16 bar
<b>Medium:</b>	Compressed air or other technical gas neutral to the structural materials used
<b>Outlet pressure range:</b>	0.5—3.0; 0.5—7.0; 0.5—12.0 bar
<b>Operating temperature range:</b>	0 to + 50°C
<b>Operating position:</b>	vertical, tanks down
<b>Lubricator drip start:</b>	3m <sup>3</sup> /h
<b>Recommended oil:</b>	mineral oil free from water and acids, with a viscosity of 2-4°E/50°C
<b>Construction materials:</b>	
<b>Body</b>	- aluminium alloy
<b>Tanks</b>	- transparent polycarbonate
<b>Tank cover</b>	- plastic
<b>Body cover</b>	- plastic
<b>Filter cartridge</b>	- polyethylene composite or bronze sinter
<b>Seals</b>	- oil resistant rubber
<b>Connection thread:</b>	G3/8; G1/2

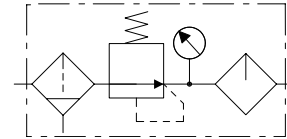

### DIMENSIONS

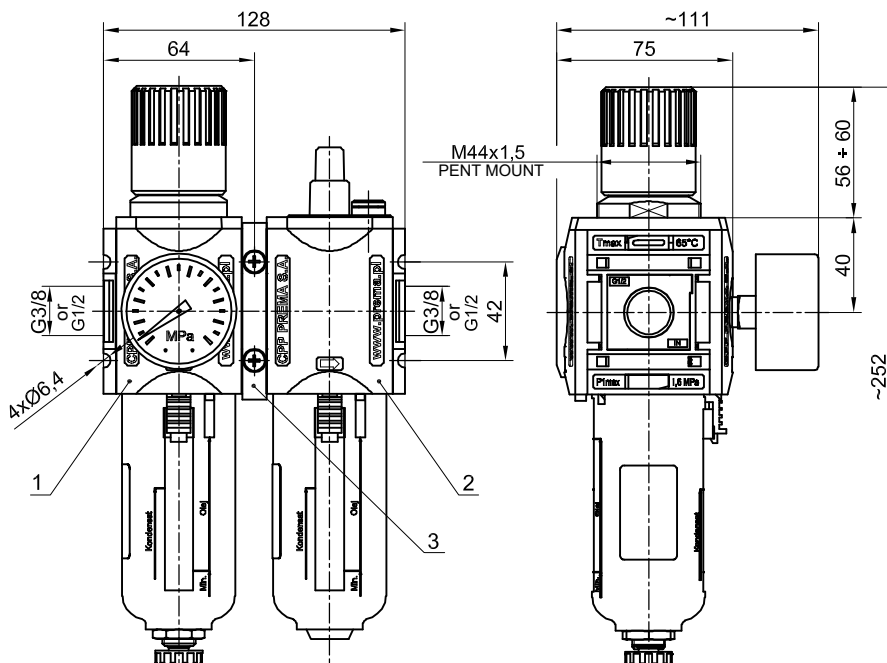

The components of the two-element compressed air preparation block G3/8 - G1/2 are:  
1) filtering and reduction unit, 2) compressed air lubricator, 3) connection screws.

# NOVA SERIES

Two-element compressed air preparation block  
(filtering and reduction unit, lubricator)



## ORDER NUMBERS

Connection thread	Outlet pressure range [MPa]	Micron rating [µm]	Order number
G3/8	0.05 — 0.30	5	50.2502.3803.05
	0.05 — 0.70		50.2502.3807.05
	0.05 — 1.20		50.2502.3812.05
	0.05 — 0.30	10	50.2502.3803.10
	0.05 — 0.70		50.2502.3807.10
	0.05 — 1.20		50.2502.3812.10
	0.05 — 0.30	40	50.2502.3803.40
	0.05 — 0.70		50.2502.3807.40
	0.05 — 1.20		50.2502.3812.40
G1/2	0.05 — 0.30	5	50.2502.1203.05
	0.05 — 0.70		50.2502.1207.05
	0.05 — 1.20		50.2502.1212.05
	0.05 — 0.30	10	50.2502.1203.10
	0.05 — 0.70		50.2502.1207.10
	0.05 — 1.20		50.2502.1212.10
	0.05 — 0.30	40	50.2502.1203.40
	0.05 — 0.70		50.2502.1207.40
	0.05 — 1.20		50.2502.1212.40

## ORDERING PROCEDURE

In your order, please specify: the name, connection thread, order number and number of pieces, e.g.:

**Two-element NOVA G1/2 compressed air preparation block, no. 50.2502.1207.40 1 pc.**

## ADDITIONAL ELEMENTS:

Fasteners for NOVA compressed air preparation block	page 9.11.02.01-02
Repair kits for NOVA compressed air preparation block	page: filtering and reduction unit 9.12.09 lubricator 9.12.12

### TECHNICAL SPECIFICATIONS

<b>Maximum inlet pressure:</b>	16 bar	
<b>Medium:</b>	Compressed air or other technical gas neutral to the structural materials used	
<b>Outlet pressure range:</b>	0.5 – 16 bar	
<b>Operating temperature range:</b>	0 to + 60°C	
<b>Recommended oil:</b>	mineral oil free of water and acids	
<b>Construction materials:</b>		
<b>Body</b> aluminium alloy <b>Tank</b> according to the table <b>Head</b> NBR brass <b>Seals</b> NBR <b>Membrane</b> NBR brass		
<b>Connection thread:</b>	G1; G 1 1/4; G 1 1/2	

### DIMENSIONS

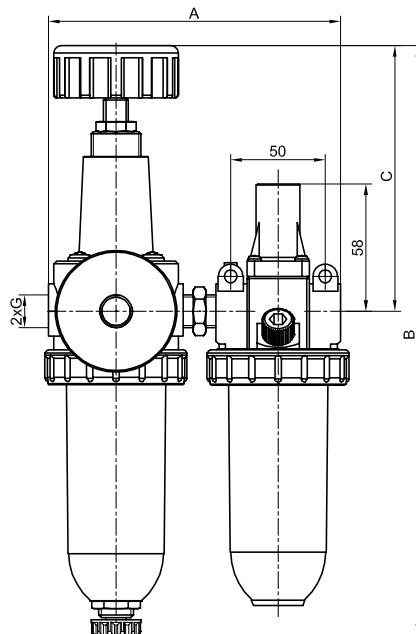

### ORDER NUMBERS

Connection thread	Tank material	Adjustment range	A	B	C	Order number
<b>Flow rate: 4000 l/min</b>						
<b>G1</b>	plastic	0.50 - 10 bar	220	452	190.6	<b>80.0502.101051</b>
	metal	0.50 - 16 bar	220	452	190.6	<b>80.0502.101063</b>
	plastic with metal cover	0.50 - 10 bar	220	454.6	190.6	<b>80.0502.101057</b>

### ORDERING PROCEDURE

In your order, please specify: the name, connection thread, order number and number of pieces, e.g.:  
**Compressed air preparation block MAXI G1, no. 80.0502.101051 1 pc.**



### TECHNICAL SPECIFICATIONS

<b>Maximum inlet pressure:</b>	12 bar
<b>Medium:</b>	Compressed air or other technical gas neutral to the structural materials used
<b>Outlet pressure range:</b>	0.5—3.0; 0.5—7.0; 0.5—12.0 bar
<b>Operating temperature range:</b>	0 to + 65°C
<b>Operating position:</b>	vertical, tanks down
<b>Lubricator drip start:</b>	3m <sup>3</sup> /h
<b>Recommended oil:</b>	mineral oil free from water and acids, with a viscosity of 2-4°E/50°C
<b>Construction materials:</b>	
<b>Body</b>	- zinc alloy
<b>Tanks</b>	- transparent polycarbonate
<b>Filter cartridge</b>	- bronze sinter
<b>Stream whirl element</b>	- plastic
<b>Seals</b>	- oil resistant rubber (NBR)
<b>Connection thread:</b>	G3/8; G1/2; G3/4

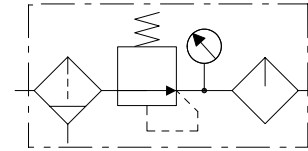

### DIMENSIONS

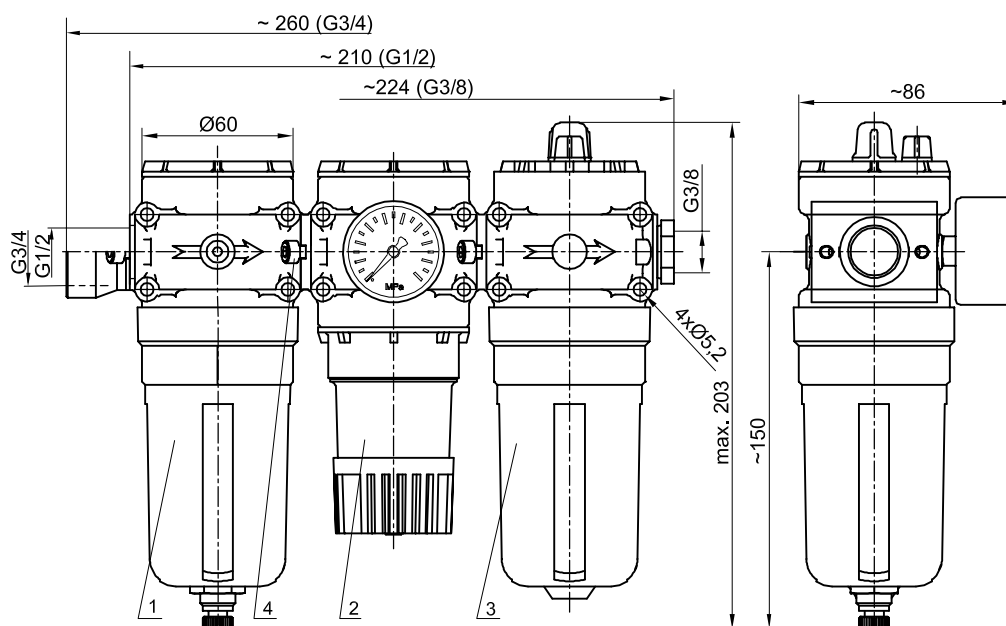

The components of the three-element compressed air preparation block G3/8, G1/2, G3/4 are:  
1) compressed air filter, 2) reducing valve, 3) compressed air lubricator, 4) connecting screws.

Please note: The G3/8 connection thread is obtained by screwing a R1/2 x G3/8 reducer screw plug into the connection threads



# CLASSIC SERIES

Compressed air preparation block  
three elements (filter, reducing valve, lubricator)



## ORDER NUMBERS

Connection thread	Outlet pressure range [MPa]	Micron rating [ $\mu\text{m}$ ]	Order number
G3/8	0.05 — 0.30	5	50.1503.3803.05
	0.05 — 0.70		50.1503.3807.05
	0.05 — 1.20		50.1503.3812.05
	0.05 — 0.30	10	50.1503.3803.10
	0.05 — 0.70		50.1503.3807.10
	0.05 — 1.20		50.1503.3812.10
	0.05 — 0.30	40	50.1503.3803.40
	0.05 — 0.70		50.1503.3807.40
	0.05 — 1.20		50.1503.3812.40
G1/2	0.05 — 0.30	5	50.1503.1203.05
	0.05 — 0.70		50.1503.1207.05
	0.05 — 1.20		50.1503.1212.05
	0.05 — 0.30	10	50.1503.1203.10
	0.05 — 0.70		50.1503.1207.10
	0.05 — 1.20		50.1503.1212.10
	0.05 — 0.30	40	50.1503.1203.40
	0.05 — 0.70		50.1503.1207.40
	0.05 — 1.20		50.1503.1212.40
G3/4	0.05 — 0.30	5	50.1503.3403.05
	0.05 — 0.70		50.1503.3407.05
	0.05 — 1.20		50.1503.3412.05
	0.05 — 0.30	10	50.1503.3403.10
	0.05 — 0.70		50.1503.3407.10
	0.05 — 1.20		50.1503.3412.10
	0.05 — 0.30	40	50.1503.3403.40
	0.05 — 0.70		50.1503.3407.40
	0.05 — 1.20		50.1503.3412.40

## ORDERING PROCEDURE

In your order, please specify: the name, connection thread, order number and number of pieces, e.g.:  
**Compressed air preparation block, three-element CLASSIC G1/2 no. 50.1503.1207.40 1 pc.**

## ADDITIONAL ELEMENTS:

Fasteners for CLASSIC compressed air preparation block	page 9.11.01.01.01.-02
Repair kits for CLASSIC compressed air preparation block	page: filter 9.12.02 reducer 9.12.05 lubricator 9.12.11

### TECHNICAL SPECIFICATIONS

<b>Maximum inlet pressure:</b>	16 bar
<b>Medium:</b>	Compressed air or other technical gas neutral to the structural materials used
<b>Outlet pressure range:</b>	0.5—3.0; 0.5—7.0; 0.5—12.0 bar
<b>Operating temperature range:</b>	0 to + 65°C
<b>Operating position:</b>	vertical, tanks down
<b>Lubricator drip start:</b>	3m <sup>3</sup> /h
<b>Recommended oil:</b>	mineral oil free from water and acids, with a viscosity of 2-4°E/50°C
<b>Construction materials:</b>	
<b>Body</b>	- aluminium alloy
<b>Tanks</b>	- transparent polycarbonate
<b>Tank cover</b>	- plastic
<b>Body cover</b>	- plastic
<b>Filter cartridge</b>	- polyethylene composite or bronze sinter
<b>Seals</b>	- oil resistant rubber
<b>Connection thread:</b>	G3/8; G1/2

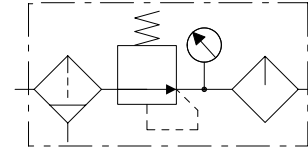

### DIMENSIONS

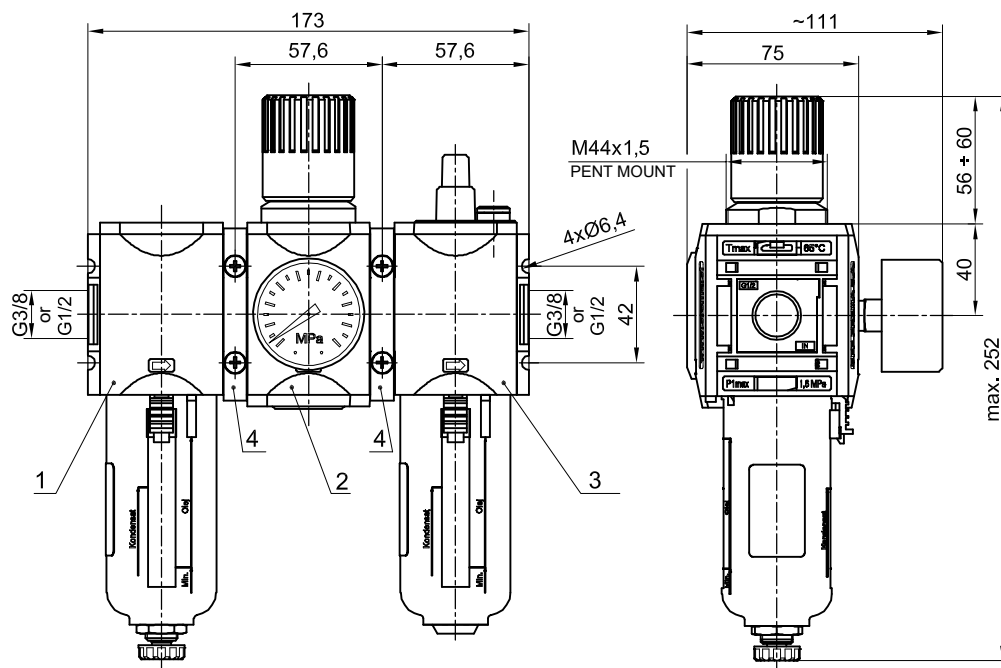

The components of the three-element compressed air preparation block G3/8 - G1/2 are:  
1) compressed air filter, 2) reducing valve, 3) compressed air lubricator, 4) connecting screws.

# NOVA SERIES

Compressed air preparation block  
three elements (filter, reducing valve, lubricator)



## ORDER NUMBERS

Connection thread	Outlet pressure range [MPa]	Micron rating [µm]	Order number
G3/8	0.05 — 0.30	5	50.2503.3803.05
	0.05 — 0.70		50.2503.3807.05
	0.05 — 1.20		50.2503.3812.05
	0.05 — 0.30	10	50.2503.3803.10
	0.05 — 0.70		50.2503.3807.10
	0.05 — 1.20		50.2503.3812.10
	0.05 — 0.30	40	50.2503.3803.40
	0.05 — 0.70		50.2503.3807.40
0.05 — 1.20	50.2503.3812.40		
G1/2	0.05 — 0.30	5	50.2503.1203.05
	0.05 — 0.70		50.2503.1207.05
	0.05 — 1.20		50.2503.1212.05
	0.05 — 0.30	10	50.2503.1203.10
	0.05 — 0.70		50.2503.1207.10
	0.05 — 1.20		50.2503.1212.10
	0.05 — 0.30	40	50.2503.1203.40
	0.05 — 0.70		50.2503.1207.40
	0.05 — 1.20		50.2503.1212.40

## ORDERING PROCEDURE

In your order, please specify: the name, connection thread, order number and number of pieces, e.g.:  
**Three-element NOVA G1/2 compressed air preparation block, no. 50.2503.1207.40 1 pc.**

## ADDITIONAL ELEMENTS:

Fasteners for NOVA compressed air preparation block	page 9.11.02.01-02
Repair kits for NOVA compressed air preparation block	page: filter 9.12.03 reducer 9.12.06 lubricator 9.12.12

## TECHNICAL SPECIFICATIONS

<b>Outlet pressure range:</b> 1.5 — 16 bar	
<b>Medium:</b> Compressed air or other technical gas neutral to the structural materials used	
<b>Operating temperature range:</b> 0 to + 60°C	
<b>Deposit tank capacity:</b> 300 cm <sup>3</sup>	
<b>Oil tank capacity:</b> 550 cm <sup>3</sup>	
<b>Construction materials:</b> <b>Body</b> - zinc alloy <b>Tanks</b> - plastic	
<b>Connection thread:</b> G1; G1 1/4; G 1 1/2	

## DIMENSIONS

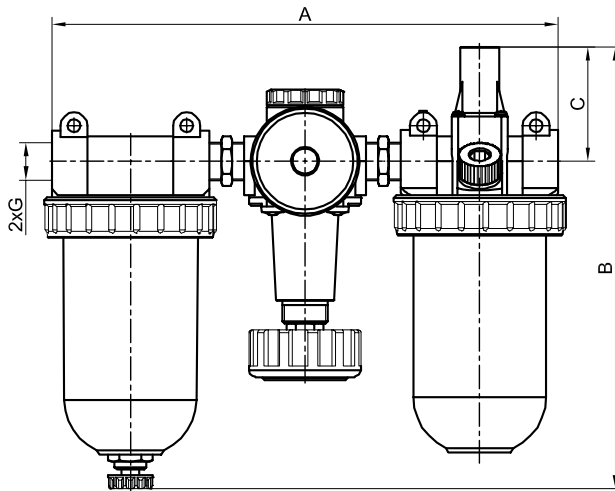

## ORDER NUMBERS

Connection thread	Tank material	Adjustment range	A	B	C	Order number
<b>Flow rate: 3200 l/min</b>						
G1	plastic	1.50 - 10 bar	302	227.9	58	80.0503.101069
	metal	1.50 - 16 bar	302	227.9	58	80.0503.101085
	plastic with metal cover	1.50 - 10 bar	302	230.5	58	80.0503.101077
<b>Flow rate: 5000 l/min</b>						
G1 1/4	plastic	1.50 - 10 bar	395	313.4	70	80.0503.101077
	metal	1.50 - 16 bar	395	313.4	70	80.0503.101086
	plastic with metal cover	1.50 - 10 bar	395	316.4	70	80.0503.101078
G1 1/2	plastic	1.50 - 10 bar	395	313.4	70	80.0503.101085
	metal	1.50 - 16 bar	395	313.4	70	80.0503.101086
	plastic with metal cover	1.50 - 10 bar	395	316.4	70	80.0503.101079

## ORDERING PROCEDURE

In your order, please specify: the name, connection thread, order number and number of pieces, e.g.:  
**Compressed air preparation block, three-element MAXI G1, no. 80.0503.101069 1 pc.**



### TECHNICAL SPECIFICATIONS

<b>Maximum inlet pressure:</b>	16 bar
<b>Medium:</b>	Compressed air or other technical gas neutral to the structural materials used
<b>Outlet pressure range:</b>	3.0 – 7.0 bar
<b>Operating temperature range:</b>	0 to + 65°C
<b>Operating position:</b>	vertical, tanks down
<b>Lubricator drip start:</b>	3m <sup>3</sup> /h
<b>Recommended oil:</b>	mineral oil free from water and acids, with a viscosity of 2-4°E/50°C
<b>Construction materials:</b>	
<b>Body</b>	- aluminium alloy
<b>Tanks</b>	- transparent polycarbonate
<b>Tank cover</b>	- plastic
<b>Body cover</b>	- plastic
<b>Filter cartridge</b>	- polyethylene composite or bronze sinter
<b>Seals</b>	- oil resistant rubber
<b>Connection thread:</b>	G3/8; G1/2

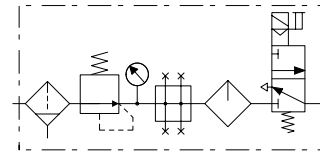

### DIMENSIONS

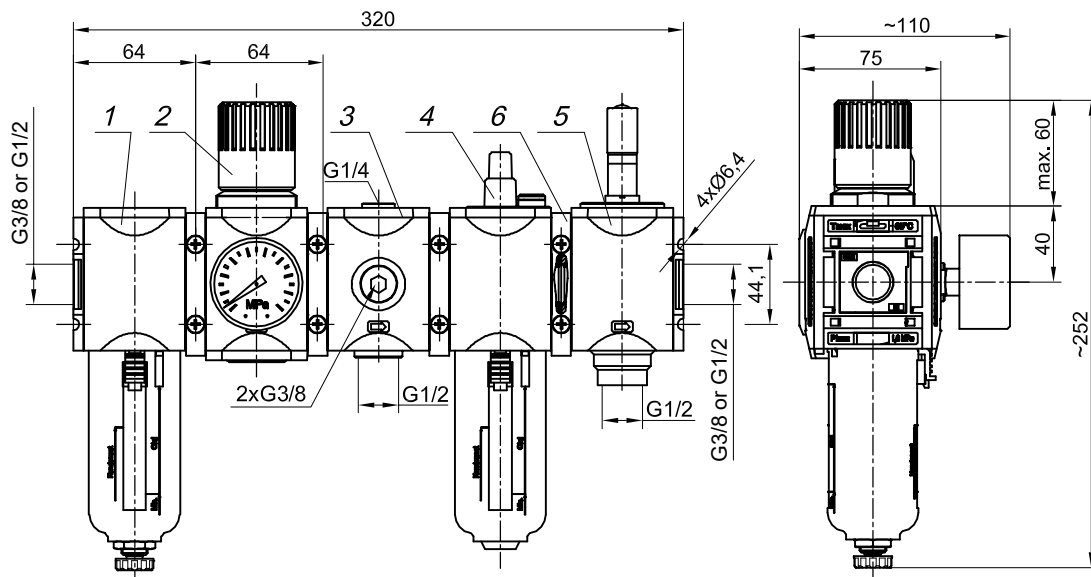

The components of the five-element compressed air preparation block G3/8-G1/2 are:

1) compressed air filter, 2) reducing valve, 3) air distribution valve, 4) compressed air lubricator, 5) cut-off valve, 6) connecting screws.

# NOVA SERIES

Compressed air preparation block, five elements  
(filter, reduction valve, lubricator, distribution valve, cut-off valve)



## ORDER NUMBERS

Connection thread	Outlet pressure range [MPa]	Micron rating [ $\mu\text{m}$ ]	Order number
G3/8	0.05 — 0.30	5	50.2502.3803.05
	0.05 — 0.70		50.2502.3807.05
	0.05 — 0.30	10	50.2502.3803.10
	0.05 — 0.70		50.2502.3807.10
	0.05 — 0.30	40	50.2502.3803.40
	0.05 — 0.70		50.2502.3807.40
G1/2	0.05 — 0.30	5	50.2502.1203.05
	0.05 — 0.70		50.2502.1207.05
	0.05 — 0.30	10	50.2502.1203.10
	0.05 — 0.70		50.2502.1207.10
	0.05 — 0.30	40	50.2502.1203.40
	0.05 — 0.70		50.2502.1207.40

## ORDERING PROCEDURE

In your order, please specify: the name, connection thread, order number and number of pieces, e.g.:

**Two-element NOVA G1/2 compressed air preparation block, no. 50.2502.1207.10 1 pc.**

## ADDITIONAL ELEMENTS:

Fasteners for NOVA compressed air preparation block	page 9.11.02.01-02
Repair kits for NOVA compressed air preparation block	page: filter 9.12.03 reducer 9.12.06 lubricator 9.12.12 cut-off valve 9.12.13

The figure on page 9.07.01.01 shows an example of a compressed air preparation block configuration. Observe the order of assembly of the basic elements of the block: filter, then the reducing valve and the lubricator. The distribution valve and cut-off valve may be located anywhere on the block, but the cut-off valve must be located behind the reducing valve.

### TECHNICAL SPECIFICATIONS

<b>Maximum operation pressure:</b>	8 bar
<b>Input pressure range:</b>	3.0 — 8.0 bar
<b>Medium:</b>	Compressed air or other technical gas neutral to the structural materials used
<b>Operating temperature range:</b>	0 to + 50°C
<b>Operating position:</b>	any position
<b>Control voltage:</b>	direct current (2.5 W power): 12 V            24 V 50 Hz alternating current (3 VA power): 24 V            110 V            230 V
<b>Construction materials:</b>	
<b>Body</b>	- aluminium alloy
<b>Body cover</b>	- plastic
<b>Seals</b>	- oil resistant rubber (NBR)
<b>Connection thread:</b>	G3/8; G1/2

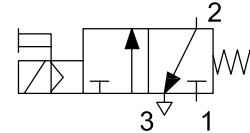

### DIMENSIONS

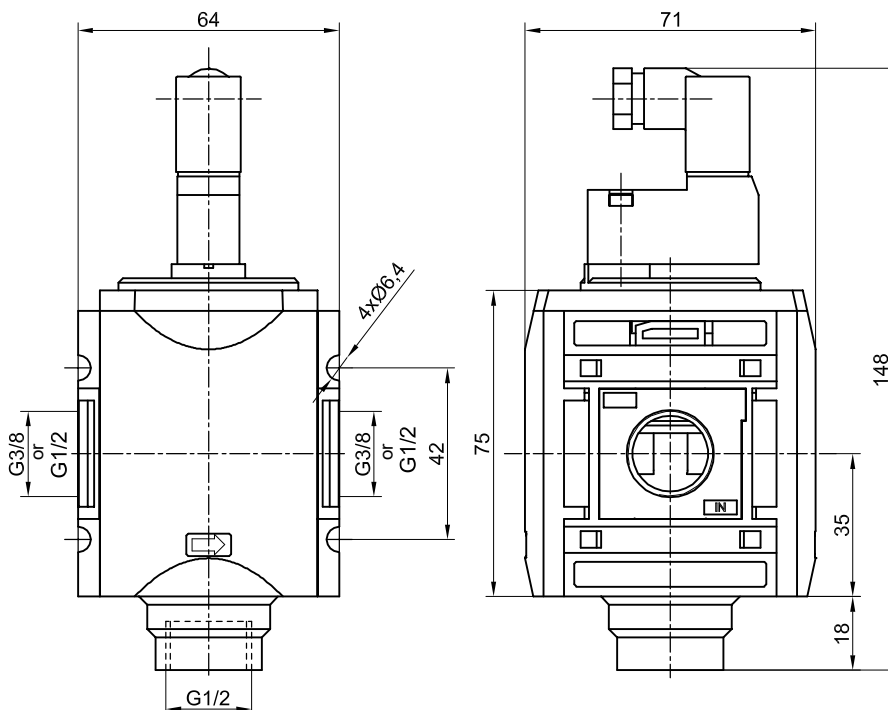



### ORDER NUMBERS

Connection thread	Order number
G3/8	50.2803.38X*
G1/2	50.2803.12X*

### ORDERING PROCEDURE

In your order, please specify: the name, connection thread, order number and number of pieces, e.g.:  
**NOVA G3/8 cut-off valve, 24V DC, no. 50.2803.38B 1 pc.**

### ADDITIONAL ELEMENTS:

Repair kits for NOVA cut-off valve	page 9.12.13
------------------------------------	--------------

\*Control voltage designation "x" in the order number.

direct current (2.5 W power):

A - 12 V      B - 24 V

50 Hz alternating current (3 VA power):

E - 24 V      H - 110 V      J - 230 V

## TECHNICAL SPECIFICATIONS

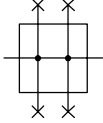
<b>Maximum inlet pressure:</b>	12 bar	
<b>Medium:</b>	Compressed air or other technical gas neutral to the structural materials used	
<b>Operating temperature range:</b>	0 to + 65°C	
<b>Operating position:</b>	any position	
<b>Construction materials:</b>		
<b>Body</b>	- aluminium alloy	
<b>Body cover</b>	- plastic	
<b>Seals</b>	- oil resistant rubber (NBR)	
<b>Connection thread:</b>	G3/8; G1/2	



## DIMENSIONS

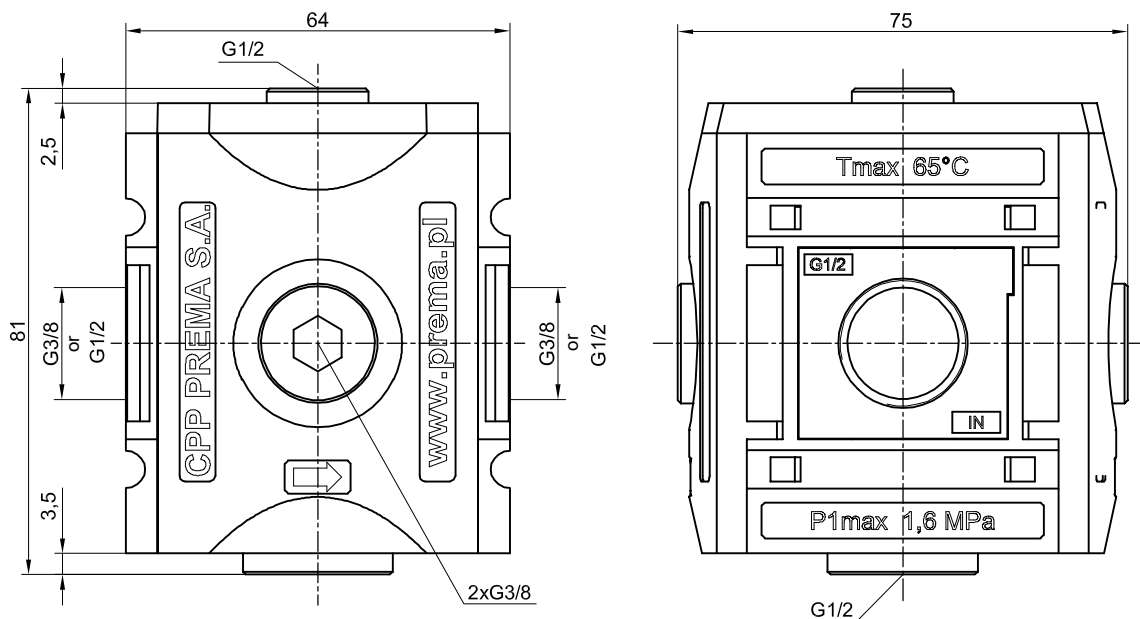

### APPLICATION EXAMPLE

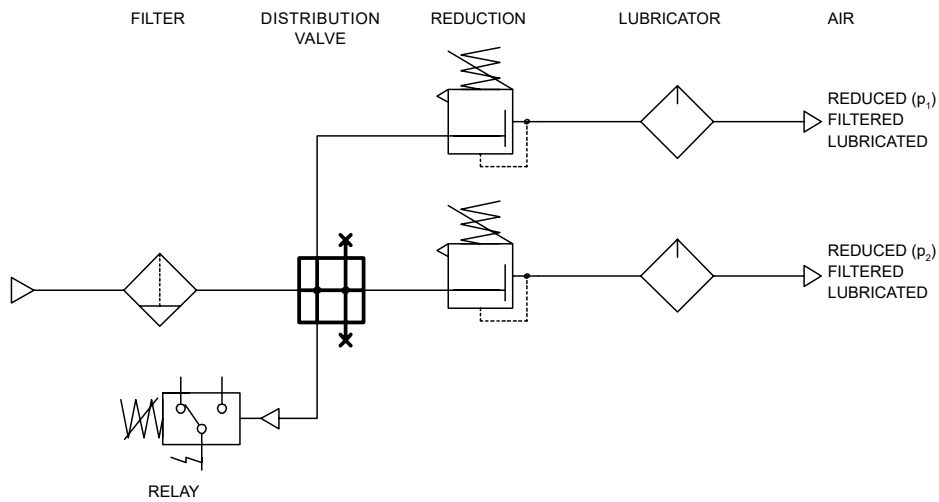

### ORDER NUMBERS

Connection thread	Order number
G3/8	50.2800.38
G1/2	50.2800.12

### ORDERING PROCEDURE

In your order, please specify: the name, connection thread, order number and number of pieces, e.g.:  
**NOVA G1/2 compressed air distribution valve, no. 50.2800.12 1 pc.**

### TECHNICAL SPECIFICATIONS

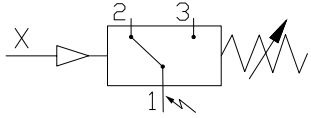
<b>Maximum inlet pressure:</b>	8 bar; 12 bar	
<b>Medium:</b>	Compressed air or other technical gas neutral to the structural materials used	
<b>Operating temperature range:</b>	0 to +65°C	
<b>Operating position:</b>	any position	
<b>Switching frequency:</b>	60 cycles/min	
<b>Construction materials:</b>		
<b>Body</b>	aluminium	
<b>Membrane</b>	nitrile-butadiene rubber	



### DIMENSIONS

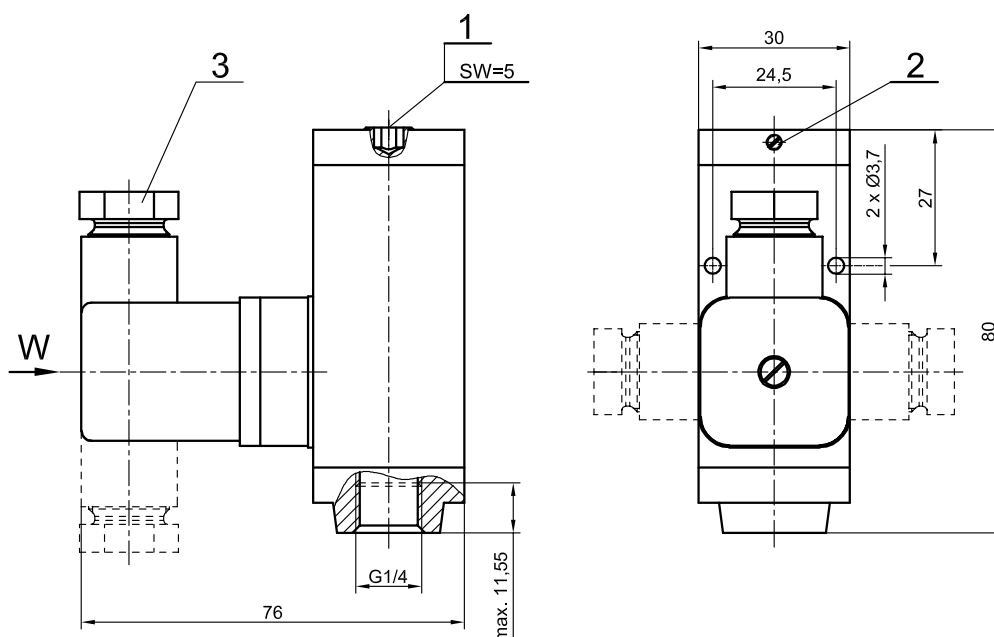

1) Adjustment screw socket, 2) adjustment screw lock screw plug, 3) plug connection rotated every 90°

Please note: The pneumo-electric relay can be installed separately or with a distribution valve.

The pneumo-electric relay can be used for all series of compressed air preparation units.

### ELECTRIC CURRENT PARAMETERS

Rated voltage (V)	Rated switching current (A)	
	Load	
	resistive	inductive $\cos\phi=0.4$
110	5.0	3.0
230	3.0	2.0
12	5.0	4.0
24	4.0	3.0
110	0.4	0.4
230	0.2	0.2

### MICROSWITCH CIRCUIT DIAGRAM

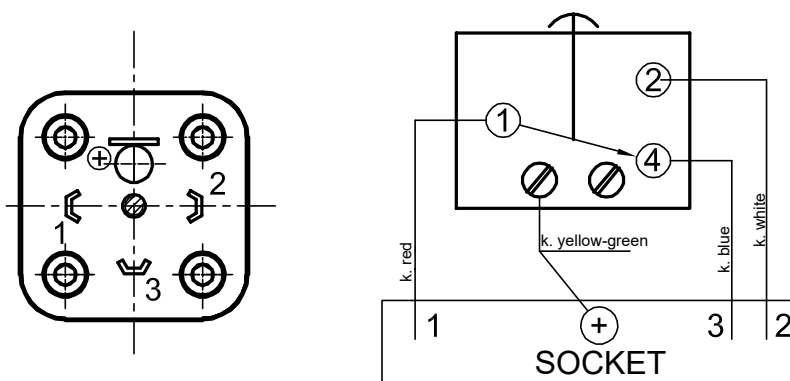

### MICROSWITCH CIRCUIT DIAGRAM

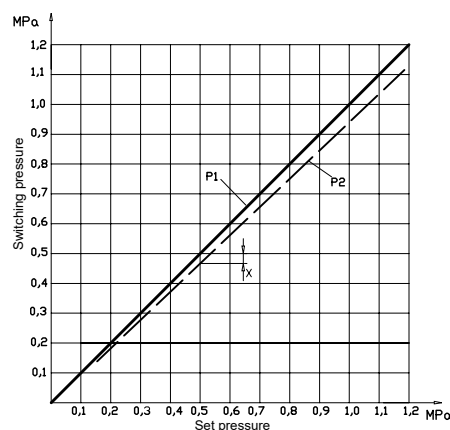

$p_1$  – upper switching pressure for pressure increase  
 $p_2$  – lower switching pressure for pressure drop  
 $X$  – hysteresis (maximum differential pressure of switching on and off)

### ORDER NUMBERS

Operating pressure range	Order number
0.2—12 bar	50.5009.0014
0.5—8 bar	50.5009.0514

### ORDERING PROCEDURE

In your order, please specify: name, order number and number of pieces, e.g.:  
**Pneumo-electric relay G1/4 no. 50.5009.0014 1 pc.**

### TECHNICAL SPECIFICATIONS

<b>Maximum inlet pressure:</b>	10 bar
<b>Medium:</b>	Compressed air, filtered and lubricated with oil mist, non-aggressive gases with a max. particle size of 40 µm
<b>Outlet pressure range:</b>	3-10 bar
<b>Operating temperature range:</b>	from -5°C to +60°C
<b>Time adjustment range:</b>	1 - 20 s
<b>Operating position:</b>	any position
<b>Construction materials:</b>	
<b>Body</b>	aluminium alloys, zinc alloys, brass
<b>Seals</b>	- nitrile rubber
<b>Connection threads</b>	G 1/8

### DIMENSIONS

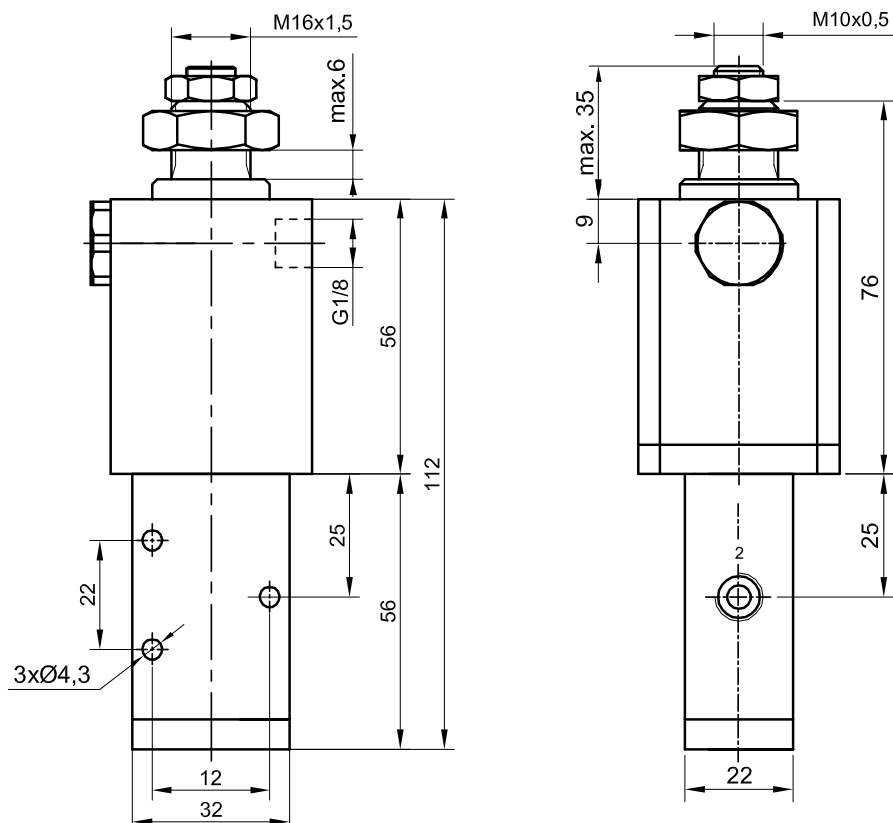

# ADDITIONAL EQUIPMENT

## Time relay



Name	Position	Graphical symbol	Order number
<b>Time relay with adjustable tank filling time</b>			<b>50.5101.32</b>
<b>Time relay with adjustable tank drain time</b>			<b>50.5102.32</b>

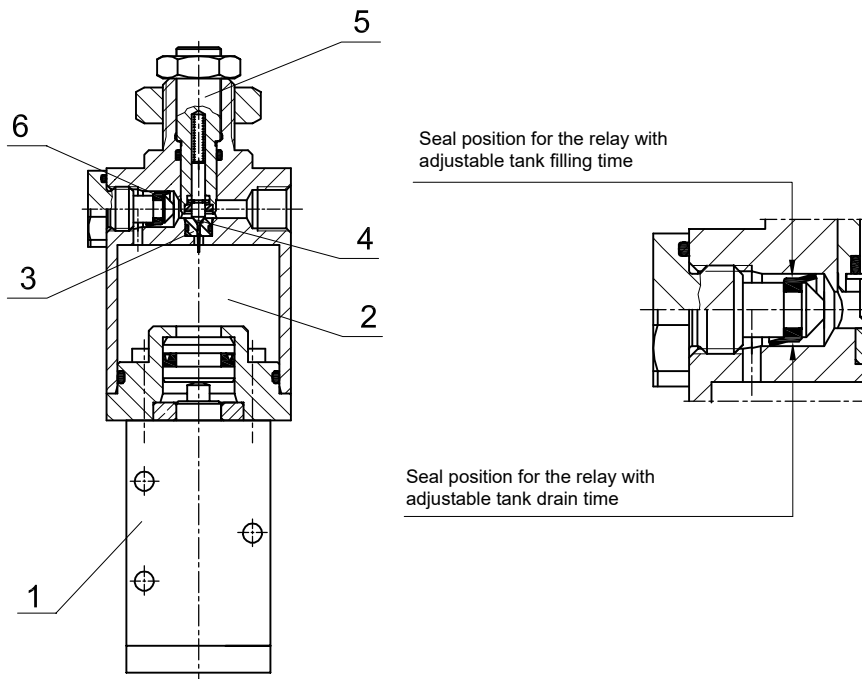

### PRINCIPLE OF OPERATION

#### Time relay with adjustable tank filling time.

The pneumatic control signal (X) fills the compressed air tank (2) via the throttle valve. The throttle valve consists of a nozzle (3), a needle (4) and an adjustment screw (5). In a check valve, a gasket serves as the control element for the direction of the medium flow. As soon as the pressure in the tank (2) reaches the appropriate value necessary to control the valve (1), the flow paths of the working medium are opened or closed in accordance with the graphic symbol of the valve.

The time required for the control of the distribution valve (1) is the delay valve actuation time and depends on the setting of the throttle valve. The change of the throttle valve setting is achieved by turning the adjustment screw (5). The connection of the opening (X) to the atmosphere immediately returns the valve (1) to its initial position according to the initial diagram. The air from the tank flows freely into the atmosphere via the check valve.

#### Time relay with adjustable tank drain time.

The distribution valve (1) is immediately controlled by the pneumatic control signal (X). The air flows freely into the tank via the check valve (2). The connection of the opening (X) with the atmosphere returns the distribution valve (1) to its initial position after the set delay time has elapsed. The air from the tank (2) flows into the atmosphere through the throttle valve.

### ORDERING PROCEDURE

In your order, please specify: name, order number and number of pieces, e.g.:  
**Time relay with adjustable tank filling time no. 50.5101.32 1 pc.**





### TECHNICAL SPECIFICATIONS

<b>Maximum supply pressure:</b>	8 bar	
<b>Control pressure:</b>	0.5 - 2.5 bar	
<b>Operating temperature range:</b>	0 to + 65°C	
<b>Medium:</b>	non-lubricated compressed air with a maximum solid particle size of 10 µm or oil mist lubricated with 40 µm solid particle size	
<b>Construction materials:</b>		
<b>Body</b>	- aluminium	
<b>Slider</b>	- stainless steel	
<b>Seals</b>	- polyurethane PU	



### DIMENSIONS

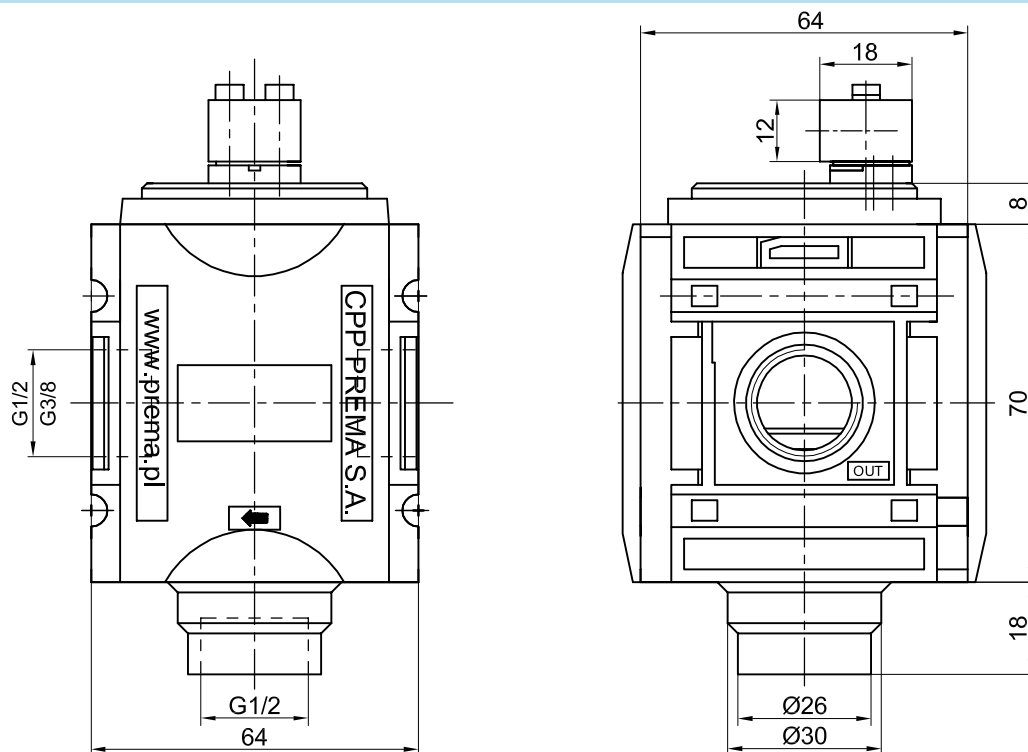

# ADDITIONAL EQUIPMENT

SOFT START valve



## ORDER NUMBERS

Connection thread	Order number
G 3/8	50.2801.38
G 1/2	50.2801.12

## ORDERING PROCEDURE

In your order, please specify: name, order number and number of pieces, e.g.:  
**SOFT START G3/8 valve no. 50.2801.38 1 pc.**

### TECHNICAL SPECIFICATIONS

<b>Maximum inlet pressure:</b>	2 bar; 10 bar; 70 bar
<b>Medium:</b>	air, hydraulic oil, oil emulsions, water
<b>Outlet pressure range:</b>	0.3-2.0 bar; 1.0-10 bar; 10-70 bar
<b>Operating temperature range:</b>	from -25°C to +85°C
<b>Operating position:</b>	any position
<b>Construction materials:</b>	
<b>Body</b>	- galvanized steel
<b>Slider</b>	- NBR



### DIMENSIONS

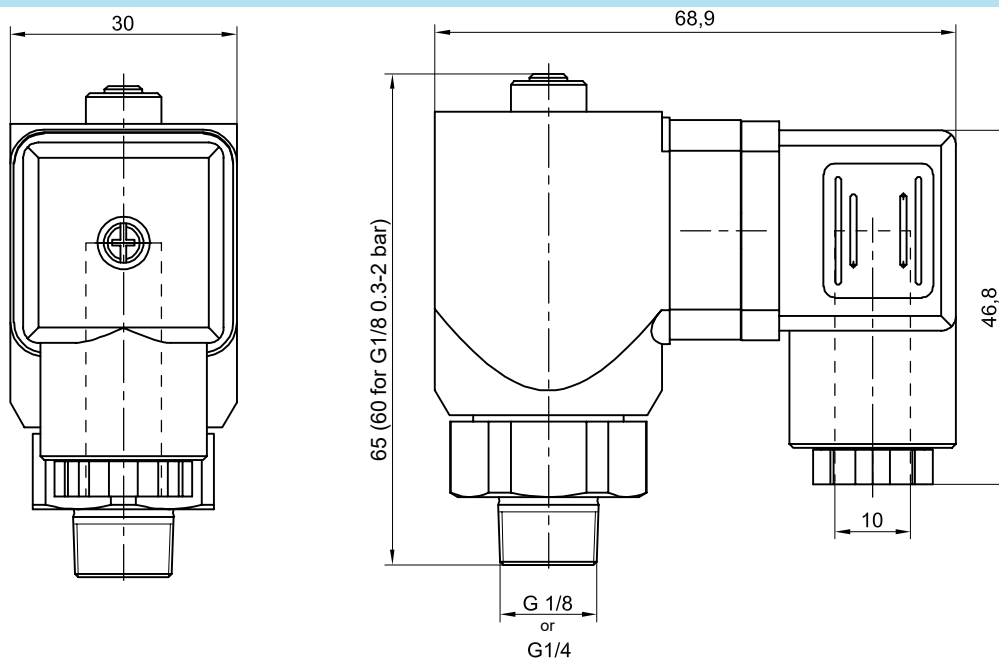

### ORDER NUMBERS

Connection thread	Pressure range	Order number
G 1/8	0.3 - 2.0 bar	85.6001.1802
G 1/8	1.0 - 10 bar	85.6002.1810
G 1/8	10 - 70 bar	85.6003.1870
G 1/4	0.3 - 2.0 bar	85.6011.1402
G 1/4	1.0 - 10 bar	85.6012.1410
G 1/4	10 - 70 bar	85.6013.1470

### ORDERING PROCEDURE

In your order, please specify: name, order number and number of pieces, e.g.:  
**Pressure sensor G1/8 no. 85.6001.1802 1 pc.**



### TECHNICAL DATA - CONTROL SWITCH

<b>Operating temperature range:</b> from -10°C to +120°C
<b>Operating position:</b> any position
<b>Construction materials:</b> brass
<b>Connection thread:</b> G1/4



### ORDER NUMBERS

Pressure range	Order number
0.2 - 8 bar	85.01SE.14
5 - 16 bar	85.02SE.14
5 - 28 bar	85.0003.14
5 - 50 bar	85.0004.14

### ORDERING PROCEDURE

In your order, please specify: the name, connection thread, order number and number of pieces, e.g.:

**Control switch G1/4 no. 85.02SE.14 1 pc.**

### TECHNICAL DATA - PRESSURE COCKS

<b>Maximum inlet pressure:</b> 16 bar
<b>Operating temperature range:</b> 0°C to +90°C
<b>Operating position:</b> any position
<b>Construction materials:</b> brass



### ORDER NUMBERS

Valve type	Connection thread	Order number
Female thread	G 1/4	85.5002.14
	G 3/8	85.5003.38
	G 1/2	85.5004.12
Female/male thread	G 1/4	85.6002.14
	G 3/8	85.6003.38
	G 1/2	85.6004.12

### ORDERING PROCEDURE

In your order, please specify: the name, connection thread, order number and number of pieces, e.g.:

**G1/4 decompression valve, no. 85.5002.14 1 pc.**



### TECHNICAL SPECIFICATIONS

<b>Version:</b>	standard, with a Bourdon tube
<b>Use:</b>	for general purpose measurement of the pressure of gases and liquids of low and medium viscosity
<b>Accuracy class:</b>	1.6; 1.9; 2.5
<b>Housing:</b>	plastic (black)
<b>Connector:</b>	brass
<b>Medium temp.:</b>	max. 60°C
<b>Ambient temp.:</b>	from -20°C to +60°C
<b>Diameters:</b>	Ø40 - Ø100 mm



### ORDER NUMBERS

Connection thread	Pressure range	Housing diameter	Mounting	Accuracy class	Order number
G1/8	0 - 4 bar	40	back	2.5	85.1640.1804
	0 - 6 bar	40	back	2.5	85.1640.1806
	0 - 10 bar	40	back	2.5	85.1640.1810
	0 - 16 bar	40	back	2.5	85.1640.1816
G1/4	0 - 1.6 bar	50	bottom	2.5	85.1612.141.6
	0 - 2.5 bar	50	bottom	2.5	85.1612.141.2
	0 - 4 bar	50	bottom	2.5	85.1612.1404
		63	bottom	1.6	85.1643.1404
	0 - 6 bar	50	bottom	2.5	85.1612.1406
		63	bottom	1.6	85.1643.1406
			back	2.5	85.7438.03063
	0 - 10 bar	50	bottom	2.5	85.1612.1410
		63	bottom	1.6	85.1643.1410
			back	2.5	85.7411.335063
	0 - 16 bar	50	bottom	2.5	85.1612.1416
		63	bottom	1.6	85.1643.1416
			back	2.5	85.7411.35363
	0 - 25 bar	50	bottom	2.5	85.1612.1425
		63	bottom	1.6	85.1643.1425
			back	2.5	85.3041.9832063
0 - 40 bar	50	bottom	2.5	85.1612.1440	
	63	bottom	1.6	85.1643.1440	



# ADDITIONAL EQUIPMENT

## Standard pressure gauges



Connection thread	Pressure range	Housing diameter	Mounting	Accuracy class	Order number
G1/2	0 - 1.6 bar	100	bottom	1.9	85.1619.121.6
	0 - 2.5 bar	100	bottom	1.9	85.1619.122.5
	0 - 4 bar	80	bottom	1.6	85.1644.1204
		100	bottom	1.6	85.1619.1204
	0 - 6 bar		80	bottom	1.6
		bottom		1.6	85.1619.1206
		100	bottom	1.9	85.1645.1206
	0 - 10 bar	80	bottom	1.6	85.1644.1210
			100	bottom	1.6
		bottom		1.9	85.1645.1210
	0 - 16 bar	80	bottom	1.6	85.1644.1216
			100	bottom	1.6
		bottom		1.9	85.1645.1216
	0 - 25 bar	80	bottom	1.6	85.1644.1225
			100	bottom	1.6
		bottom		1.9	85.1645.1225
	0 - 40 bar	80	bottom	1.6	85.1644.1240
			100	bottom	1.6
		bottom		1.9	85.1645.1240
	Compressed air preparation units, MINI series (size G1/4)				
G1/8	0 - 4 bar	40	back		59.0201.24.04
	0 - 10 bar	40	back		59.0201.24.10
	0 - 16 bar	40	back		59.0201.24.16
Compressed air preparation units, CLASSIC series (size G1/2)					
M10×1	0 - 4 bar	40	back		59.0201.24.03
	0 - 10 bar	40	back		59.0201.24.07
	0 - 16 bar	40	back		59.0201.24.12
Compressed air preparation units, NOVA series (size G3/8 - G1/2)					
G1/4	0 - 4 bar	50	back		59.2201.24.04
	0 - 10 bar	50	back		59.2201.24.10
	0 - 16 bar	50	back		59.2201.24.16

### ORDERING PROCEDURE

In your order, please specify: the name, connection thread, order number and number of pieces, e.g.:

**Standard pressure gauge G1/4 no. 59.2201.24.04 1 pc.**

### TECHNICAL SPECIFICATIONS

<b>Version:</b>	with a Bourdon tube, filled with glycerine
<b>Use:</b>	for general purpose measurement of the pressure of gases and liquids of low and medium viscosity
<b>Accuracy class:</b>	1; 1.6; 2.5
<b>Housing:</b>	stainless steel
<b>Connector:</b>	brass
<b>Medium temp.:</b>	max. 60°C
<b>Ambient temp.:</b>	from -20°C to +60°C
<b>Diameter:</b>	Ø50 mm; Ø63 mm; Ø100 mm



### ORDER NUMBERS

Connection thread	Pressure range	Housing diameter	Mounting	Accuracy class	Order number
G1/4	0 - 1.6 bar	50	back	2.5	85.1622.141.6
		63	back	1.6	85.1623.141.6
			bottom	1.6	85.1613.141.6
	0 - 2.5 bar	50	back	2.5	85.1622.142.5
		63	back	1.6	85.1623.142.5
			bottom	1.6	85.1613.142.5
	0 - 4 bar	50	back	2.5	85.1622.1404
		63	back	1.6	85.1623.1404
			bottom	1.6	85.1613.1404
	0 - 6 bar	50	back	2.5	85.1622.1406
		63	back	1.6	85.1623.1406
			bottom	1.6	85.1613.1406
	0 - 10 bar	50	back	2.5	85.1622.1410
		63	back	1.6	85.1623.1410
			bottom	1.6	85.1613.1410
	0 - 16 bar	50	back	2.5	85.1622.1416
		63	back	1.6	85.1623.1416
			bottom	1.6	85.1613.1416
	0 - 25 bar	50	back	2.5	85.1622.1425
		63	back	1.6	85.1623.1425
			bottom	1.6	85.1613.1425

# ADDITIONAL EQUIPMENT

## Glycerine pressure gauges



Connection thread	Pressure range	Housing diameter	Mounting	Accuracy class	Order number
G1/4	0 - 40 bar	50	back	2.5	85.1622.1440
		63	back	1.6	85.1623.1440
			bottom	1.6	85.1613.1440,
	0 - 60 bar	63	back	1.6	85.1623.1460
			bottom	1.6	85.1613.1460
	0 - 100 bar	63	back	1.6	85.1623.14100
			bottom	1.6	85.1613.14100
	0 - 160 bar	63	back	1.6	85.1623.14160
			bottom	1.6	85.1613.14160
	G1/2	0 - 1.6 bar	100	bottom	1.0
back				1.0	85.1625.121.6
0 - 2.5 bar		100	bottom	1.0	85.1615.122.5
			back	1.0	85.1625.122.5
0 - 4 bar		100	bottom	1.0	85.1615.1204
			back	1.0	85.1615.1204
0 - 6 bar		100	bottom	1.0	85.1615.1206
			back	1.0	85.1625.1206
0 - 10 bar		100	bottom	1.0	85.1615.1210
			back	1.0	85.1625.1210
0 - 16 bar		100	bottom	1.0	85.1615.1216
			back	1.0	85.1625.1216
0 - 25 bar		100	bottom	1.0	85.1615.1225
0 - 40 bar		100	bottom	1.0	85.1615.1240
0 - 60 bar		100	bottom	1.0	85.1615.1260
0 - 100 bar		100	bottom	1.0	85.1615.12100
0 - 160 bar	100	bottom	1.0	85.1615.12160	

### ORDERING PROCEDURE

In your order, please specify: the name, connection thread, order number and number of pieces, e.g.:

**Glycerine pressure gauge G1/2 no. 85.1615.12100 1 pc.**

### TECHNICAL SPECIFICATIONS

<b>Operating pressure range:</b> 250—400 bar
<b>Medium:</b> air, hydraulic oil, oil emulsions, water
<b>Operating temperature range:</b> from 0°C to +120°C
<b>Operating position:</b> any position
<b>Construction materials:</b> as in the table



### DIMENSIONS

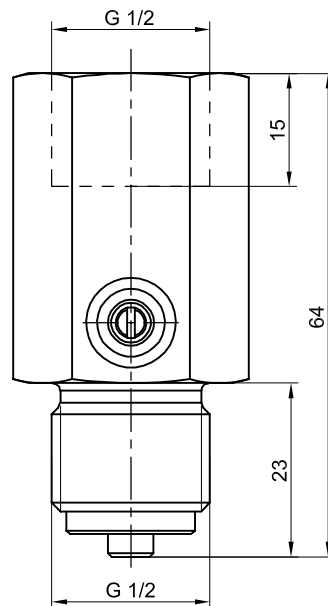

### ORDER NUMBERS

Connection thread	Material	Order number
G 1/2	brass	85.2682.12
	steel	85.2683.12
	stainless steel	85.2684.12

### ORDERING PROCEDURE

In your order, please specify: the name, connection thread, material, order number and number of pieces, e.g.:  
**Reducing valve G1/2, brass no. 85.2682.12 1 pc.**



## BRACKET FOR AIR PREPARATION ELEMENTS G1/2

### INSTALLATION OF INDIVIDUAL ELEMENTS

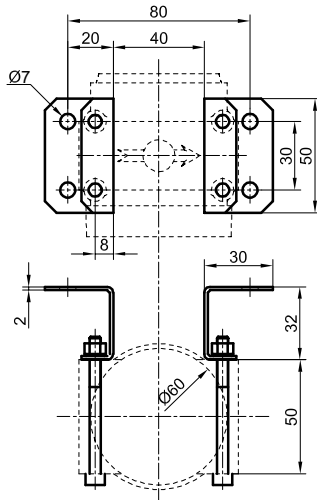

### INSTALLATION OF AIR PREPARATION BLOCKS

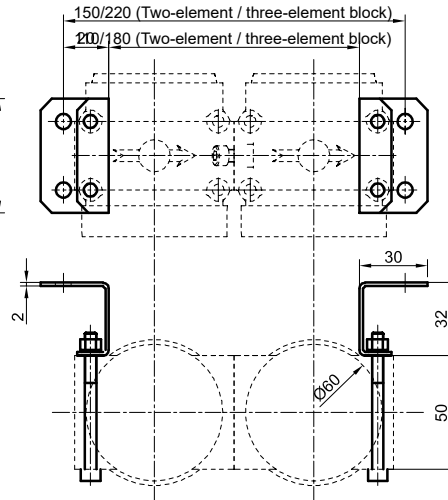

NAME OF ELEMENT	DIAGRAM	ORDER NUMBER
bracket for air preparation units G1/2		50.0504.12.12

**Please note:** the set consists of two brackets including fixing bolts, washers and nuts

### ANGLE BRACKET

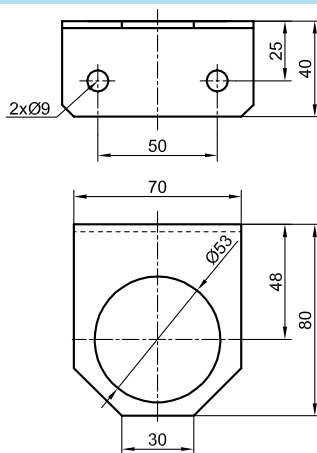

### ANGLE BRACKET COMPLETE WITH NUT

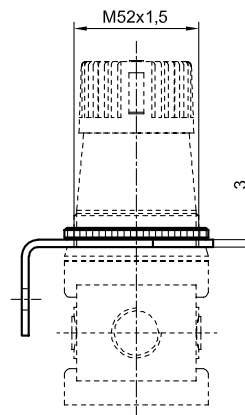

NAME OF ELEMENT	DIAGRAM	ORDER NUMBER
angle bracket for reducing valve G1/2		50.0504.12.01
angle bracket type for reducing valve G1/2 complete with nut		50.0504.12.11

### NUT FOR PENT MOUNTING

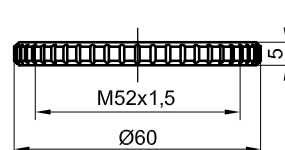

ORDER NUMBER:	59.1101.15
---------------	------------

# MOUNTING BRACKETS

for the MINI series



## BRACKET FOR AIR PREPARATION UNITS G1/4

### MOUNTING BRACKET

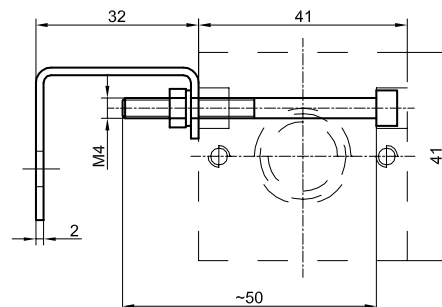
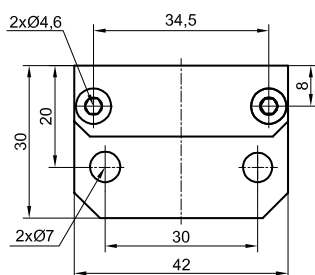

NAME OF ELEMENT	DIAGRAM	ORDER NUMBER
angle bracket for reducing valve G1/4		50.0504.14.12

**Please note:** the set consists of a bracket with fastening screws, washers and nuts

### ANGLE BRACKET

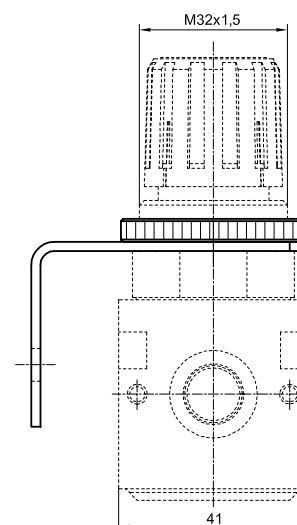
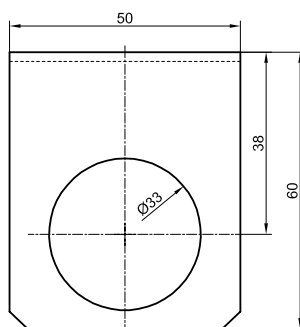
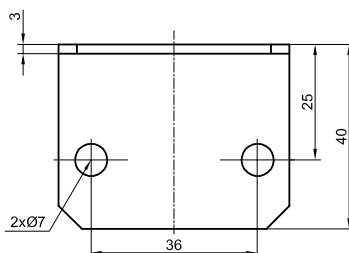

NAME OF ELEMENT	DIAGRAM	ORDER NUMBER
bracket for air preparation units G1/4		50.0504.14.01

## MOUNTING NUT

It is used for a pent mounting of a reducer, a filtering and reducing valve or a two-element compressed air preparation block, "NOVA" series

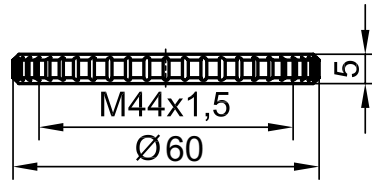

ORDER NUMBER:

59.2101.15

## MPSP-1 TYPE BRACKET, ANGLE BRACKET COMPLETE WITH NUT

Used for mounting of a reducer, a filtering and reducing valve or a two-element compressed air preparation block, "NOVA" series

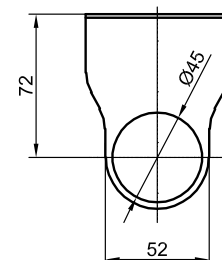
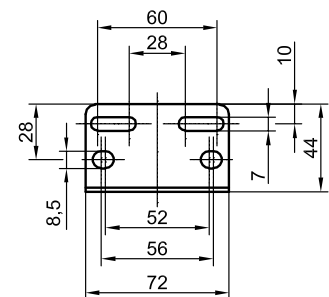
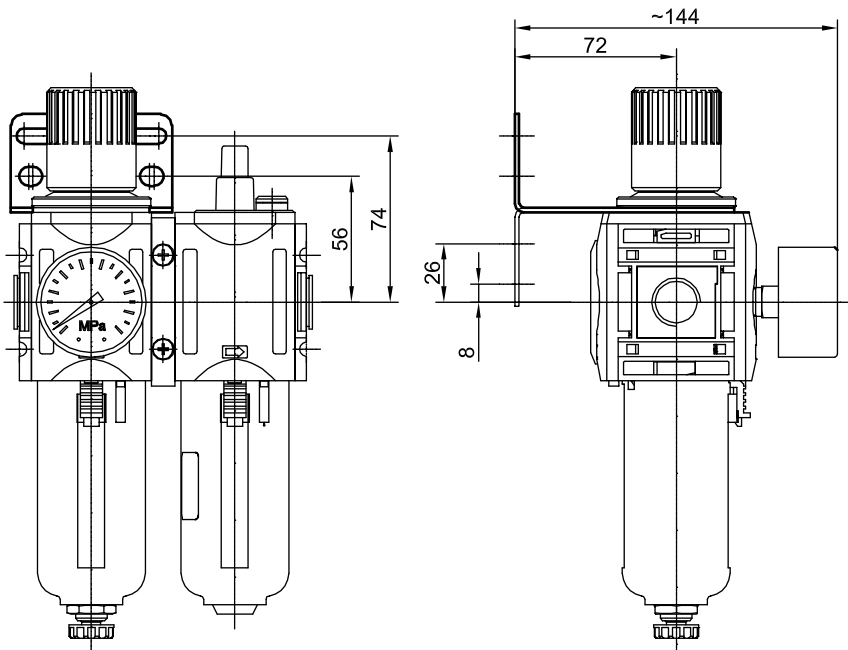

ORDER NUMBER:

59.2503.0103



# MOUNTING BRACKETS

for the NOVA series



## MPSP-2 MOUNTING BRACKET, FOR THREE-ELEMENT CAP BLOCK

Used for mounting a three-element "NOVA" series compressed air preparation block.

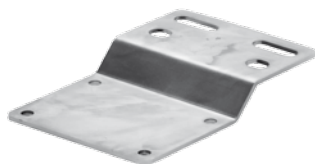
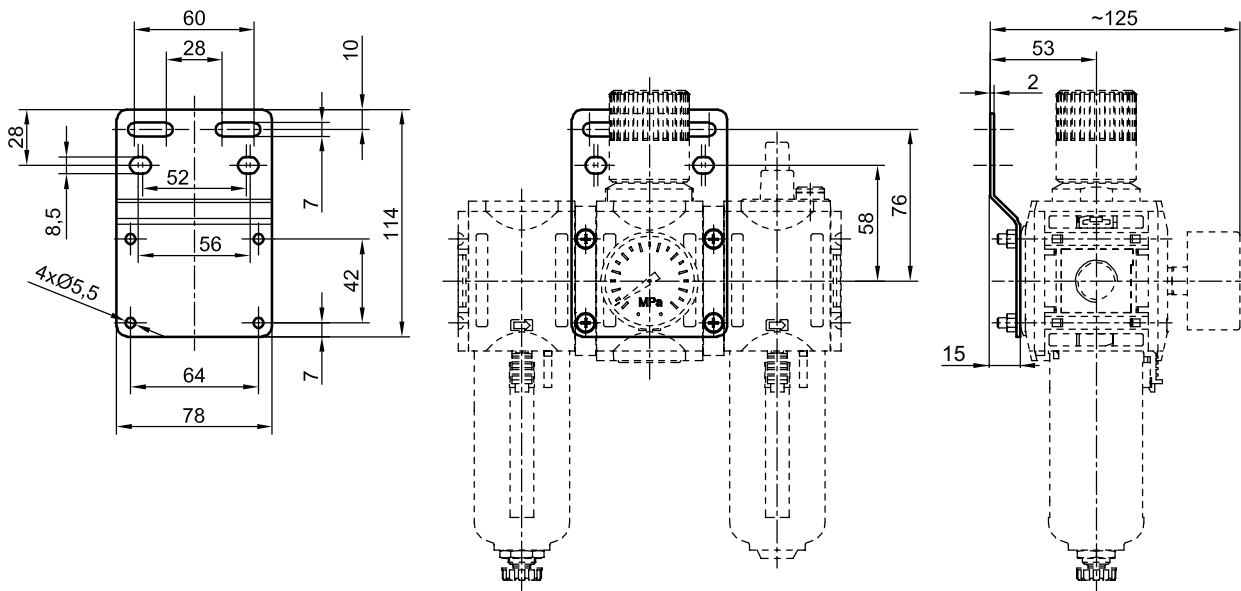

ORDER NUMBER:	59.2503.0104
---------------	--------------

## MPSP-3 MOUNTING BRACKET, FOR THREE-ELEMENT CAP BLOCK

Used for mounting a three-element "NOVA" series compressed air preparation block. Stable mounting of the CAP block requires the use of two brackets (set contains 1 piece).

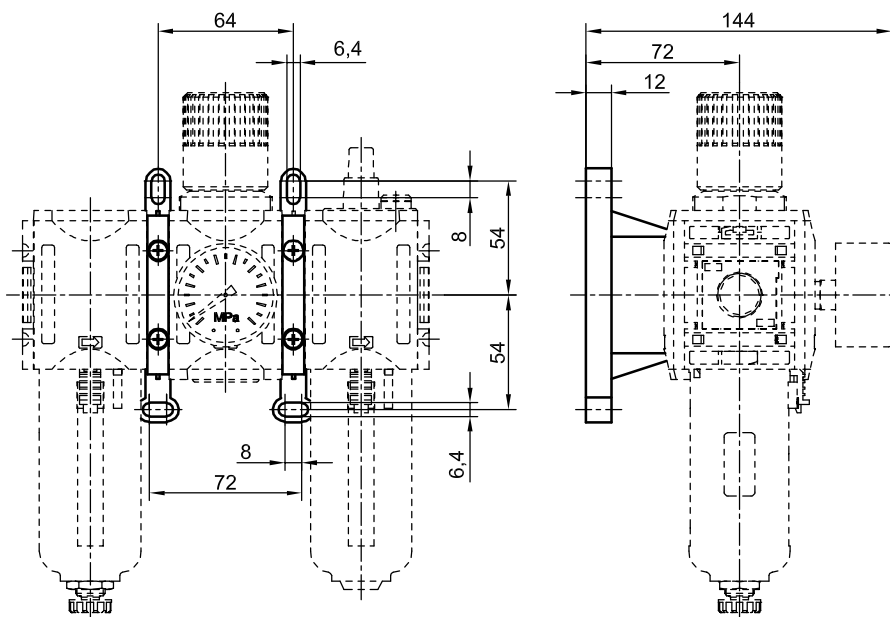

ORDER NUMBER:	59.2503.0101
---------------	--------------

## FILTER G 1/2

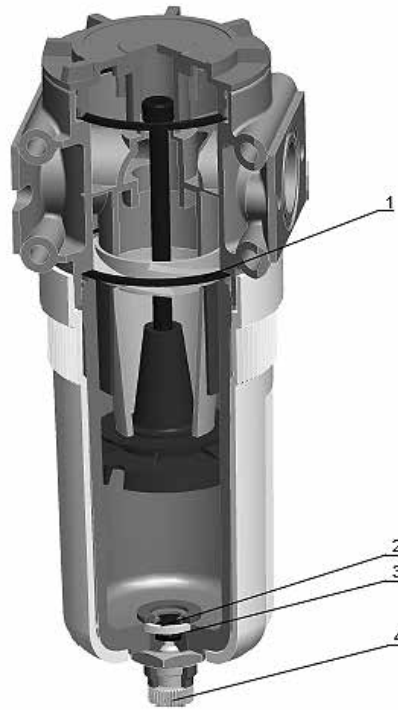

No.	Spare part name	Quantity	Spare part number	Repair kit number
1	Sealing ring 1	2	59.0201.44	<b>59.0001.KN</b>
2	Drain valve washer	1	59.0201.06	
3	Sealing ring 2	1	19.0001.38	
4	Drain plug	1	59.0201.03	

## ORDERING PROCEDURE

In your order, please specify:  
the name of the spare part or repair kit, order number and number of pieces, e.g.:  
**Drain plug for CLASSIC filter No. 59.0201.03 1 pc.**

## FILTER G 1/4

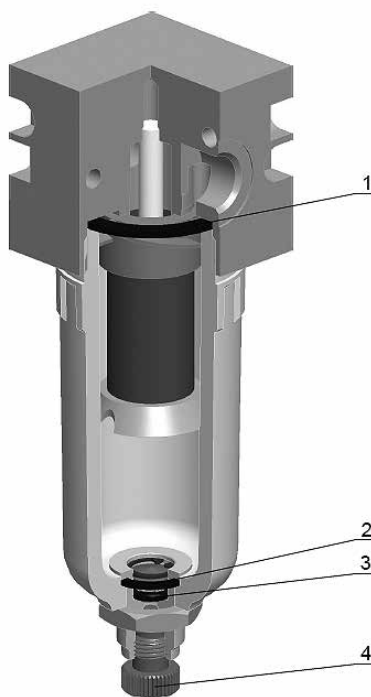

No.	Spare part name	Quantity	Spare part number	Repair kit number
1	Sealing ring 1	1	59.0201.66	<b>59.0001.KN.18</b>
2	Sealing ring 2	1	19.0001.0038	
3	Sealing ring 3	1	19.0001.0106	
4	Drain plug	1	59.0201.03	

## ORDERING PROCEDURE

In your order, please specify:  
 the name of the spare part or repair kit, order number and number of pieces, e.g.:  
**Drain plug for MINI filter no. 59.0201.03 1 pc.**

## FILTER G 3/8 - G 1/2

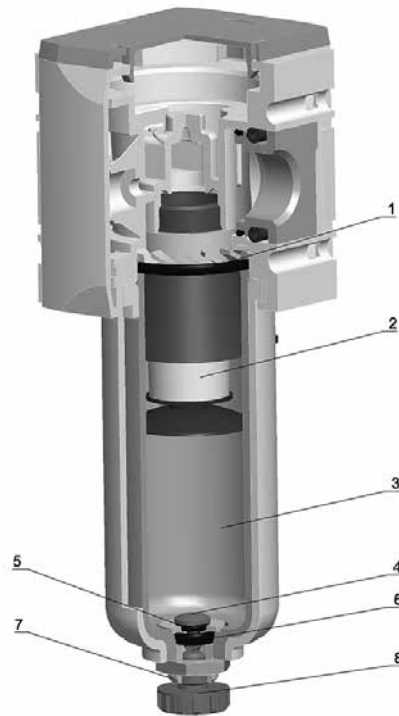

No.	Spare part name	Quantity	Spare part number	Repair kit number
1	Sealing ring 1*	1	19.0001.0100	<b>59.2001.KN</b>
2	Filter cartridge			
	– 5 µm	1	59.2001.11.03	
	– 10 µm	1	59.2001.11.02	
	– 40 µm	1	59.2001.11.01	
3	Filter tank complete	1	59.2001.011	
4	Head*	1	59.2001.16	
5	Sealing ring 2	1	19.0001.0038	
6	Sealing ring 3*	1	19.0001.0104	
7	Drain valve complete	1	59.2001.02	
8	Drain plug*	1	59.2001.17	

\*- parts of the repair kit

## ORDERING PROCEDURE

In your order, please specify:  
the name of the spare part or repair kit, order number and number of pieces, e.g.:  
**Drain plug for NOVA filter No. 59.2001.17 1 pc.**

## REDUCING VALVE G 1/2

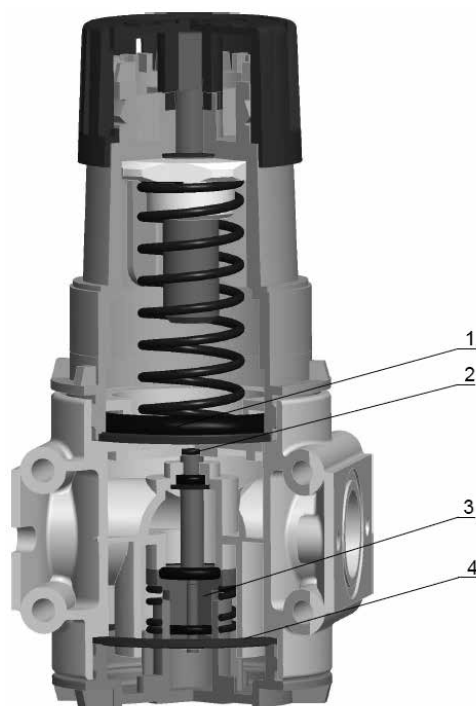

No.	Spare part name	Quantity	Spare part number	Repair kit number
1	Sealing ring 1	1	19.0001.0042	<b>59.0101.KN</b>
2	Sealing ring 2	1	19.0001.0031	
3	Head complete	1	59.0201.07	
4	Sealing ring 3	2	59.0201.44	

## ORDERING PROCEDURE

In your order, please specify:  
 the name of the spare part or repair kit, order number and number of pieces, e.g.:  
**Head complete for CLASSIC reducing valve no. 59.0201.07 1 pc.**

## REDUCING VALVE G 1/4

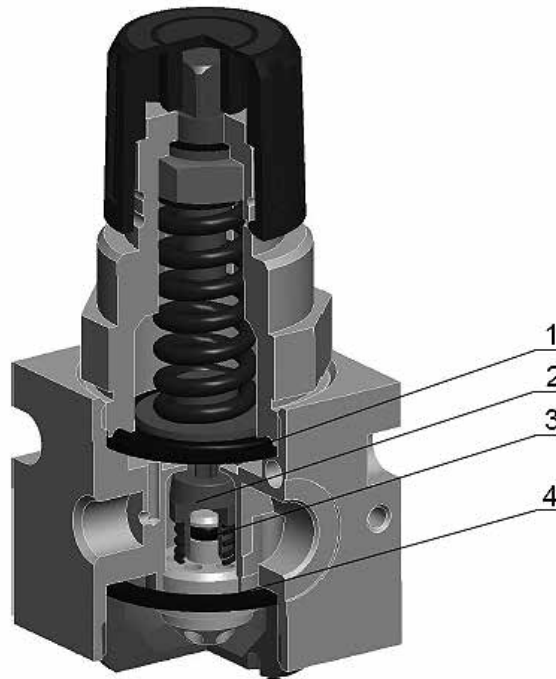

No.	Spare part name	Quantity	Spare part number	Repair kit number
1	Membrane	1	59.0201.48	<b>59.0102.KN</b>
2	Head complete	1	59.0201.07.18	
3	Sealing ring 1	1	19.0001.0062	
4	Sealing ring 2	2	59.0201.66	

## ORDERING PROCEDURE

In your order, please specify:  
 the name of the spare part or repair kit, order number and number of pieces, e.g.:  
**Head complete for MINI reducing valve no. 59.0201.07.18 1 pc.**

## REDUCING VALVE G 3/8 - G 1/2

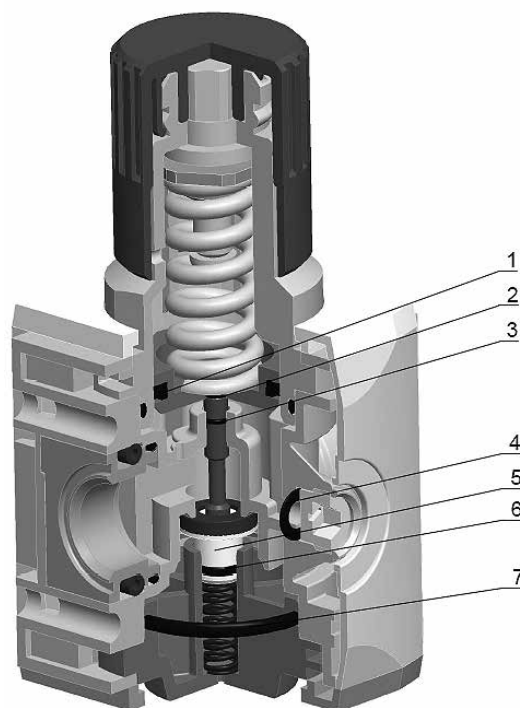

No.	Spare part name	Quantity	Spare part number	Repair kit number
1	Piston gasket	1	59.2101.05	<b>59.2101.KN</b>
2	Sealing ring 1	1	19.0001.0031	
3	Sealing ring 2	1	19.0001.0102	
4	Sealing ring 3	1	19.0001.0070	
5	Head complete	1	59.2101.07	
6	Sealing ring 4	1	19.0001.0038	
7	Sealing ring 5	2	19.0001.0100	

### ORDERING PROCEDURE

In your order, please specify:  
 the name of the spare part or repair kit, order number and number of pieces, e.g.:  
**Head complete for NOVA reducing valve no. 59.0201.07 1 pc.**

## FILTERING AND REDUCTION UNIT G 1/2

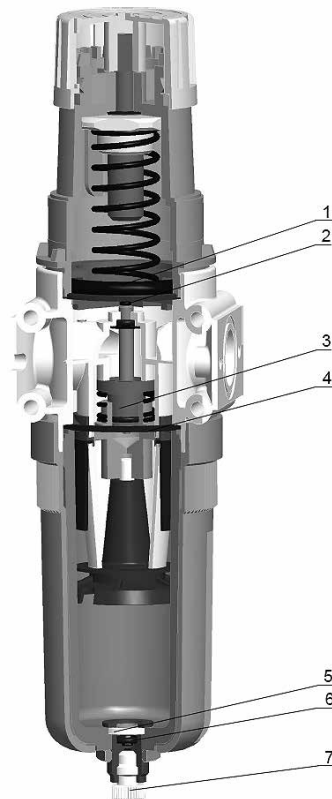

No.	Spare part name	Quantity	Spare part number	Repair kit number
1	Sealing ring 1*	1	19.0001.0042	<b>59.0201.KN</b>
2	Sealing ring 2*	1	19.0001.0031	
3	Head complete*	1	59.0201.07	
4	Sealing ring 3*	2	59.0201.44	
5	Drain valve washer	1	59.0201.06	
6	Sealing ring 4	1	19.0001.0038	
7	Drain plug	1	59.0201.03	

\*- parts of the repair kit

## ORDERING PROCEDURE

In your order, please specify:  
the name of the spare part or repair kit, order number and number of pieces, e.g.:  
**Drain plug for CLASSIC filtering and reduction unit no. 59.0201.03 1 pc.**



# REPAIR KITS

for the MINI filtering and reduction unit



## FILTERING AND REDUCTION UNIT G 1/4

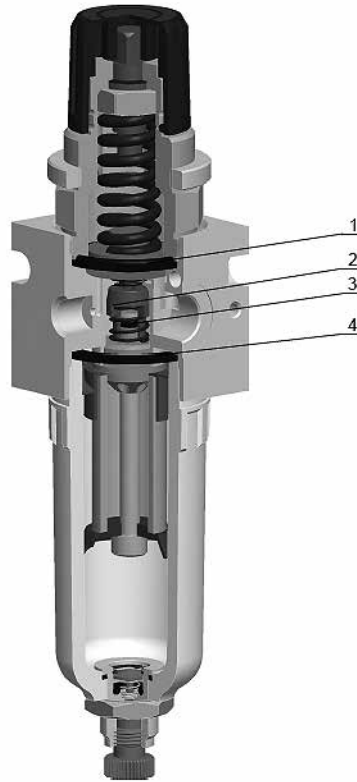

No.	Spare part name	Quantity	Spare part number	Repair kit number
1	Membrane	1	59.0201.48	<b>59.0102.KN</b>
2	Head complete	1	59.0201.07.18	
3	Sealing ring 1	1	19.0001.0062	
4	Sealing ring 2	1	59.0201.66	

## ORDERING PROCEDURE

In your order, please specify:  
the name of the spare part or repair kit, order number and number of pieces, e.g.:  
**Diaphragm for MINI filtering and reduction unit no. 59.0201.48 1 pc.**

## FILTERING AND REDUCTION UNIT G 3/8 - G 1/2

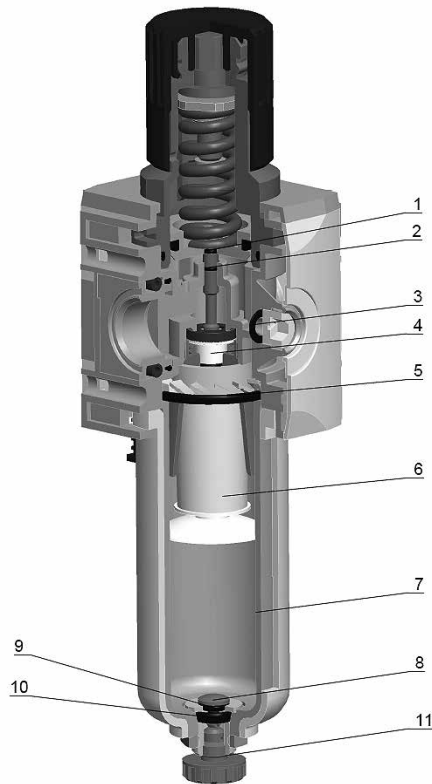

No.	Spare part name	Quantity	Spare part number	Repair kit number
1	Sealing ring 1*	1	19.0001.0031	59.2201.KN
2	Sealing ring 2*	1	19.0001.0102	
3	Sealing ring 3*	1	19.0001.0070	
4	Head complete*	1	59.2101.07	
5	Sealing ring 4*	1	19.0001.0100	
6	Filter cartridge			
	– 5 µm	1	59.2001.11.03	
	– 10 µm	1	59.2001.11.02	
	– 40 µm	1	59.2001.11.01	
7	Filter tank complete	1	59.2001.011	
8	Head*	1	59.2001.16	
9	Sealing ring 5*	1	19.0001.0038	
10	Sealing ring 6*	1	19.0001.0104	
11	Drain valve complete	1	59.2001.02	

\*- parts of the repair kit

## ORDERING PROCEDURE

In your order, please specify:  
the name of the spare part or repair kit, order number and number of pieces, e.g.:  
**Head complete for NOVA filtering and reduction unit no. 59.2101.07 1 pc.**

## LUBRICATOR G 1/2

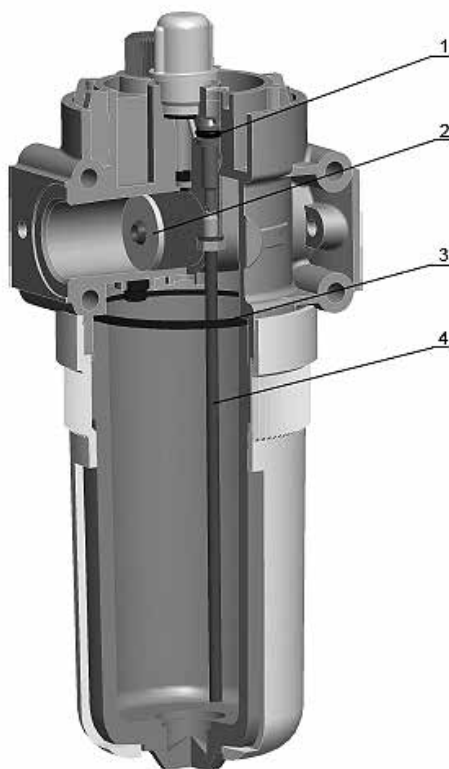

No.	Spare part name	Quantity	Spare part number	Repair kit number
1	Sealing ring 1*	1	19.0001.0056	<b>59.0301.KN</b>
2	Diaphragm*	1	59.0301.03	
3	Sealing ring 2*	1	59.0201.44	
4	Suction tube	1	59.0301.16	

\*- parts of the repair kit

## ORDERING PROCEDURE

In your order, please specify:  
 the name of the spare part or repair kit, order number and number of pieces, e.g.:  
**Diaphragm for CLASSIC lubricator no. 59.0301.03 1 pc.**

## LUBRICATOR 1/4

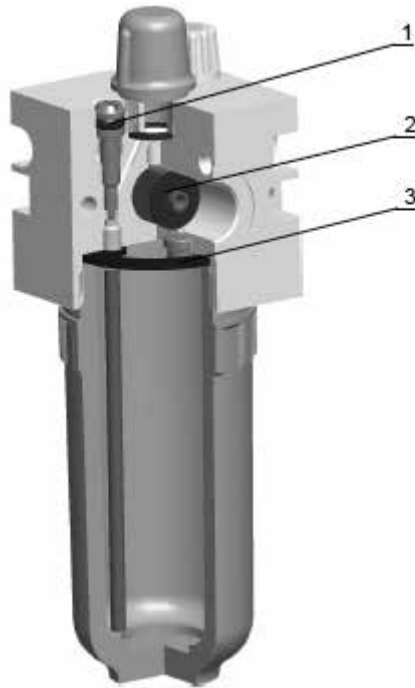

No.	Spare part name	Quantity	Spare part number	Repair kit number
1	Sealing ring 1	1	19.0001.0056	<b>59.0301.KN.18</b>
2	Membrane	1	59.0201.03	
3	Sealing ring 2	1	59.0301.07	

## ORDERING PROCEDURE

In your order, please specify:  
the name of the spare part or repair kit, order number and number of pieces, e.g.:  
**Diaphragm for MINI lubricator no. 59.0201.03 1 pc.**

## LUBRICATOR G 3/8 - G 1/2

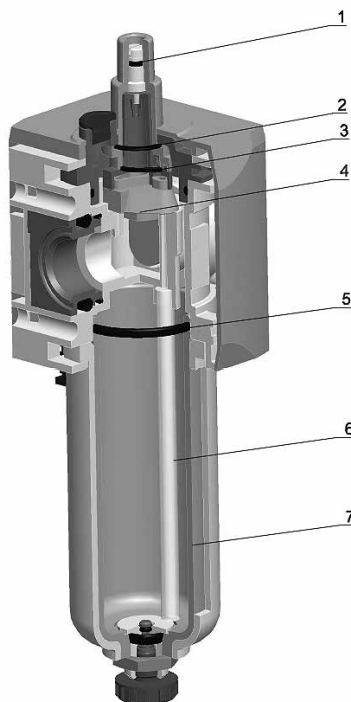

No.	Spare part name	Quantity	Spare part number	Repair kit number
1	Sealing ring 1*	1	19.0001.0101	<b>59.2301.KN</b>
2	Sealing ring 2*	1	19.0001.0103	
3	Shaped gasket*	1	59.2301.06	
4	Diaphragm*	1	59.2301.03	
5	Sealing ring 3*	1	19.0001.0100	
6	Suction tube	1	59.2301.15	
7	Lubricator tank complete	1	59.2001.0	

\*- parts of the repair kit

### ORDERING PROCEDURE

In your order, please specify:  
 the name of the spare part or repair kit, order number and number of pieces, e.g.:  
**Diaphragm for NOVA lubricator no. 59.2301.03 1 pc.**

## CUT-OFF VALVE

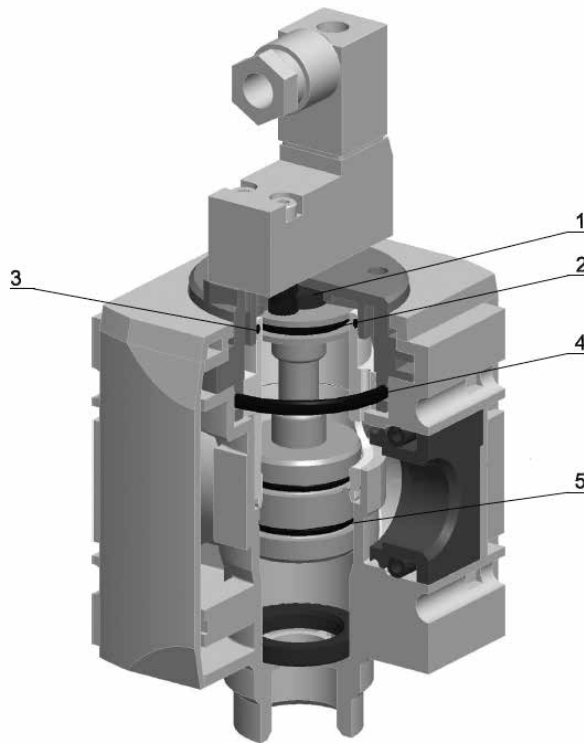

No.	Spare part name	Quantity	Spare part number	Repair kit number
1	Stop	1	29.0314	<b>50.2803.KN</b>
2	AIRZET seal	1	19.018D.04A	
3	Sealing ring 1	1	19.0001.0117	
4	Sealing ring 2	1	19.0001.0100	
5	Sealing ring 4	2	19.0001.0065	

## ORDERING PROCEDURE

In your order, please specify:  
the name of the spare part or repair kit, order number and number of pieces, e.g.:  
**End stop for NOVA cut-off valve no. 29.0314 1 pc.**

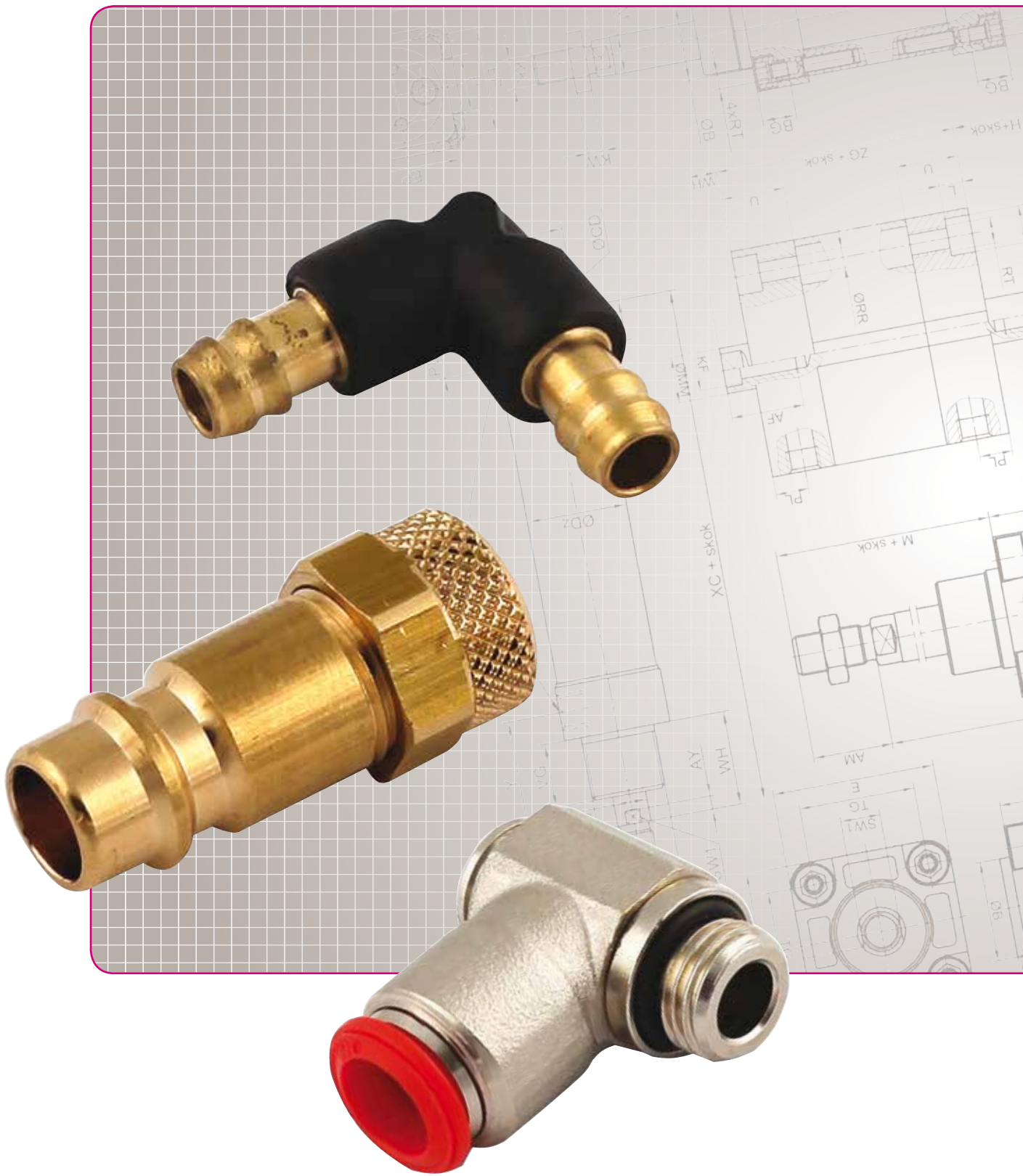

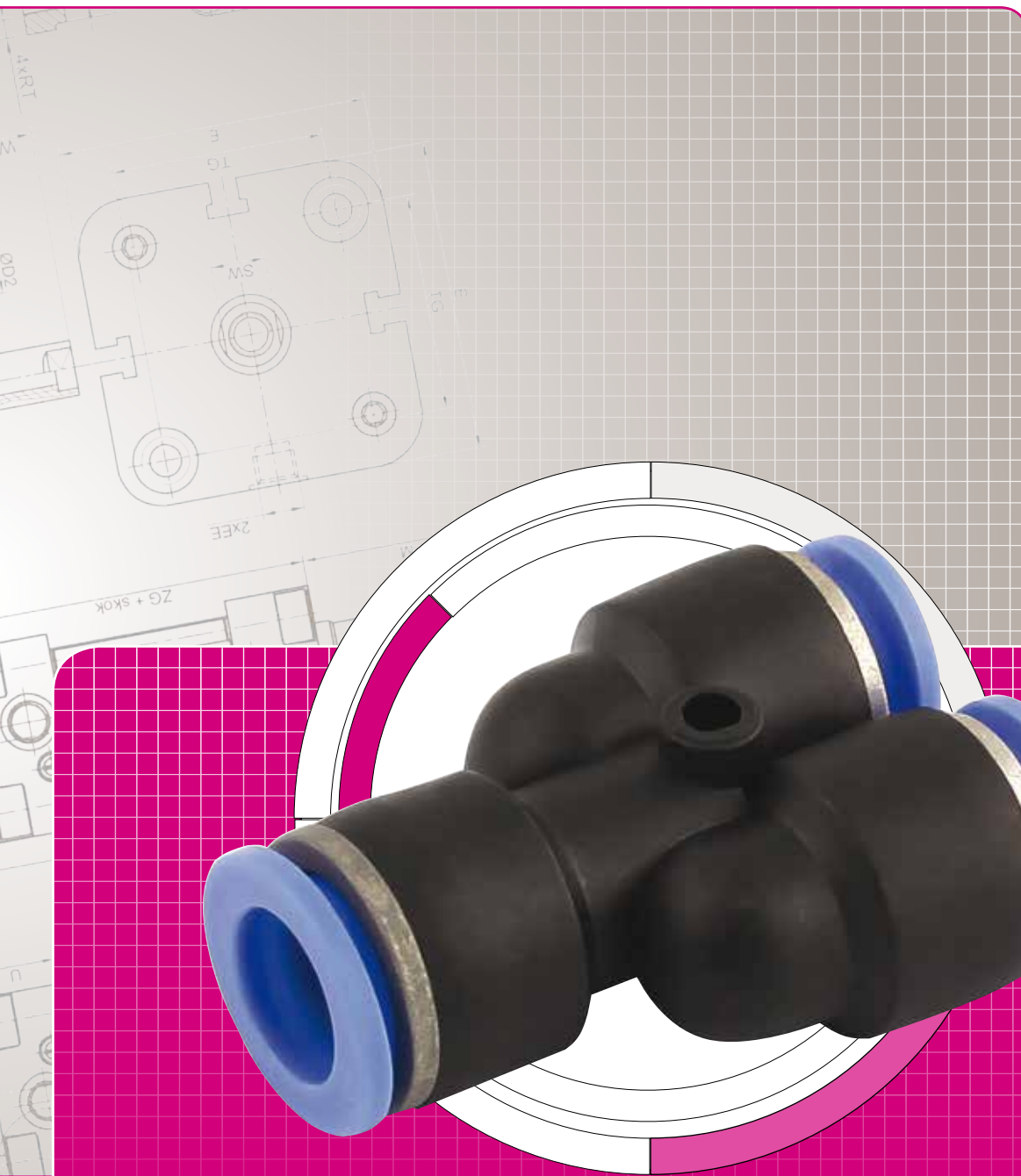

# FITTINGS AND ACCESSORIES



## Fittings, accessories and hoses

- 10.01.** Push-in connectors
- 10.02.** Throttle and throttle-check valves
- 10.03.** Screw connectors
- 10.04.** Push-in connectors for pipes
- 10.05.** Threaded connectors
- 10.06.** Barbed connectors
- 10.07.** Quick couplings and nozzles
- 10.08.** Accessories for pneumatics
- 10.09.** Hoses
- 10.10.** Compressors
- 10.11.** Accessories

# 10

## TECHNICAL SPECIFICATIONS

<b>Maximum operating pressure:</b>	15 bar
<b>Medium:</b>	compressed air or other non-aggressive gas (including vacuum)
<b>Operating temperature range:</b>	-18 to +70°C
<b>Materials:</b>	
<b>Body</b>	- brass / OT58 UNI 5705
<b>Ring</b>	- plastic
<b>Insert</b>	- brass / OT58 UNI 5705
<b>Spring ring</b>	- stainless steel
<b>Ring</b>	- brass / OT58 UNI 5705
<b>Lip seal</b>	- NBR70
<b>Sealing ring</b>	- NBR 70

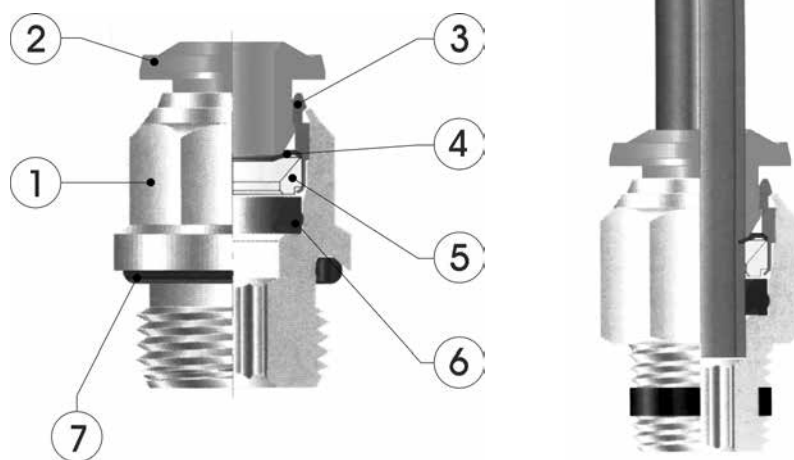

1) Body, 2) Ring, 3) Insert, 4) Spring ring, 5) Ring, 6) Lip seal, 7) Seal. ring

Push-in fittings for plastic hoses are used to connect pneumatic systems and pneumatic components.

The hose is sealed in the fitting by inserting the cut end into the fitting opening until resistance is noted. To disconnect the hose, press down on the plastic ring and remove the hose from the fitting while holding it pressed down.

Straight push-in fittings can be tightened with a spanner in hard-to-reach places.

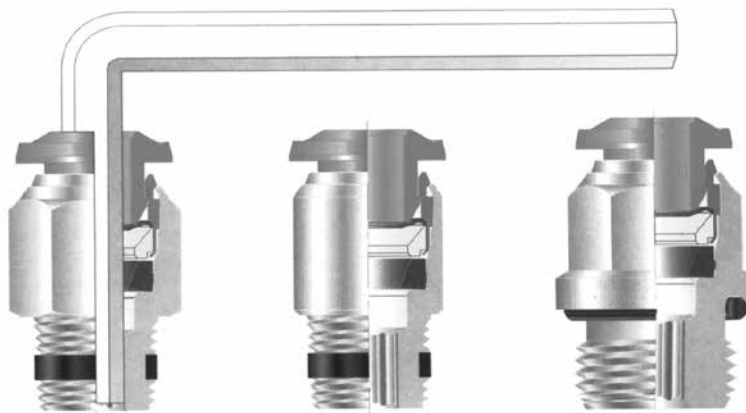

### 80.0050.01

STRAIGHT PUSH-IN FITTING

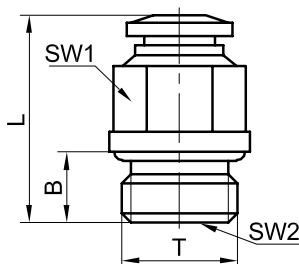

T	HOSE	B	L	SW1	SW2	Order no.
	ØDz					
M5	4	4	20	10	2	80.0050.01.0504
M5	6	5	23	13	2	80.0050.01.0506
M12x1.25	6	8	24	13	4	80.0050.01.1206
M12x1.5	6	8	24	13	4	80.0050.01.1306
M12x1.5	8	8	28	14	6	80.0050.01.1308
G1/8	4	6	20	10	3	80.0050.01.1804
G1/8	6	6	23	13	4	80.0050.01.1806
G1/8	8	6	25	14	5	80.0050.01.1808
G1/4	4	8	20	13	3	80.0050.01.1404
G1/4	6	8	24	13	4	80.0050.01.1406
G1/4	8	8	23	14	6	80.0050.01.1408
G1/4	10	8	31	17	6	80.0050.01.1410
G3/8	6	9	25	13	4	80.0050.01.3806
G3/8	8	9	24	14	6	80.0050.01.3808
G3/8	10	9	28	17	8	80.0050.01.3810
G3/8	12	9	34	20	8	80.0050.01.3812
G1/2	6	10	27	13	4	80.0050.01.126
G1/2	8	10	27	14	6	80.0050.01.1208
G1/2	10	10	27	17	8	80.0050.01.1210
G1/2	12	10	31	22	10	80.0050.01.1212
G1/2	14	10	32	22	10	80.0050.01.1214

Material: nickel-plated brass

### 80.0050.02

STRAIGHT PUSH-IN FITTING

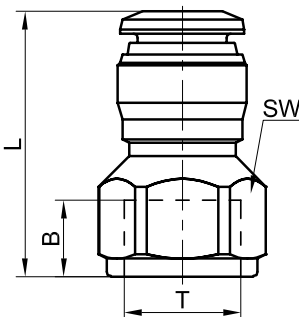

T	HOSE	B	L	SW	Order no.
	ØDz				
G1/8	4	8	24	13	80.0050.02.1804
G1/8	6	8	26	13	80.0050.02.1806
G1/8	8	8	27	15	80.0050.02.1808
G1/4	4	11	28	16	80.0050.02.1404
G1/4	6	11	30	16	80.0050.02.1406
G1/4	8	11	30	17	80.0050.02.1408
G1/4	10	11	34	17	80.0050.02.1410
G3/8	8	12	32	19	80.0050.02.3808
G3/8	10	12	34	19	80.0050.02.3810
G3/8	12	12	36	21	80.0050.02.3812
G1/2	10	15	34	19	80.0050.02.1210
G1/2	12	15	41	24	80.0050.02.1212

Material: nickel-plated brass

### 80.0050.13

SWIVEL ANGLE PUSH-IN FITTING

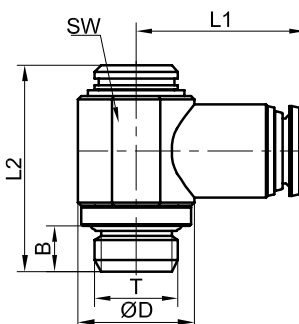

T	HOSE	B	ØD	L1	L2	SW1	Order no.
	ØDz						
M5	4	5	9	19	25	-	80.0050.13.M504
M5	6	5	9	21	25	-	80.0050.13.M506
G1/8	4	6	14	21	27	5	80.0050.13.1804
G1/8	6	6	14	23	27	5	80.0050.13.1806
G1/8	8	6	14	24	27	5	80.0050.13.1808
G1/4	6	8	18	25	30	6	80.0050.13.1406
G1/4	8	8	18	26	30	6	80.0050.13.1408
G1/4	10	8	18	29	30	6	80.0050.13.1410
G1/4	12	8	18	31	30	6	80.0050.13.1412
G3/8	8	9	21	28	36	7	80.0050.13.3808
G3/8	10	9	21	31	36	7	80.0050.13.3810
G3/8	12	9	19	33	36	7	80.0050.13.3812

Material: nickel-plated brass

T	HOSE ØDz	B	L1	L2	SW1	SW2	Order no.
M5	4	3.5	18	17.5	9	8	80.0050.04.M504
M5	6	3.5	21	20	11	11	80.0050.04.M506
M12x1.25	6	7.5	20	22	11	16	80.0050.04.1206
M12x1.5	6	7.5	20	22	11	16	80.0050.04.1306
M12x1.5	8	7.5	22.5	23.5	12	16	80.0050.04.1308
G1/8	4	5.5	18	18	9	13	80.0050.04.1804
G1/8	6	5.5	21	20	11	13	80.0050.04.1806
G1/8	8	5.5	22.5	22.5	12	13	80.0050.04.1808
G1/4	4	7	18	18	9	16	80.0050.04.1404
G1/4	6	7	21	21.5	11	16	80.0050.04.1406
G1/4	8	7	22.5	23	12	16	80.0050.04.1408
G1/4	10	7	26.5	25.5	14	16	80.0050.04.1410
G1/4	12	8	31.5	27.5	16	20	80.0050.04.1412
G3/8	8	8	22.5	25	12	20	80.0050.04.3808
G3/8	10	8	26.5	25	14	20	80.0050.04.3810
G3/8	12	8	31.5	27	16	20	80.0050.04.3812
G1/2	8	9.5	22.5	26.5	12	25	80.0050.04.1208
G1/2	10	9.5	26.5	26.5	14	25	80.0050.04.1210
G1/2	12	9.5	31.5	28.5	16	25	80.0050.04.1212
G1/2	14	9.5	32.5	29	16	25	80.0050.04.1214

Material: nickel-plated brass

T	HOSE ØDz	B	L1	L2	SW	Order no.
R1/8	4	7	17	16	9	80.0050.05.1804
R1/8	6	7	21	18	11	80.0050.05.1806
R1/8	8	7	23	19	13	80.0050.05.1808
R1/4	6	11	21	22	11	80.0050.05.1406
R1/4	8	11	23	22	13	80.0050.05.1408
R1/4	10	11	27	24	16	80.0050.05.1410
R1/4	12	11	31	28	19	80.0050.05.1412
R3/8	8	11	25	24	12	80.0050.05.3808
R3/8	10	11	27	24	16	80.0050.05.3810
R3/8	12	11	31	28	19	80.0050.05.3812

Material: nickel-plated brass

T	HOSE ØDz	B	L1	L2	SW1	SW2	Order no.
G1/8	4	6	17	38	9	13	80.0050.06.1804
G1/8	6	6	21	40	11	16	80.0050.06.1806
G1/8	8	6	23	41	13	13	80.0050.06.1808
G1/4	4	8	17	45	9	16	80.0050.06.1404
G1/4	6	8	21	46	11	16	80.0050.06.1406
G1/4	8	8	23	47	13	16	80.0050.06.1408
G1/4	10	8	27	49	16	16	80.0050.06.1410
G3/8	8	9	23	50	13	18	80.0050.06.3808
G3/8	10	9	27	52	16	18	80.0050.06.3810

Material: nickel-plated brass

T	HOSE ØDz	B	L1	L2	SW1	SW2	Order no.
G1/8	4	6	34	23	9	13	80.0050.10.1804
G1/8	6	6	42	25	11	13	80.0050.10.1806
G1/8	8	6	45	26	13	13	80.0050.10.1808
G1/4	6	8	42	28	11	16	80.0050.10.1406
G1/4	8	8	45	29	13	16	80.0050.10.1408
G1/4	10	8	53	31	16	16	80.0050.10.1410
G3/8	8	9	50	25	12	18	80.0050.10.3808
G3/8	10	9	53	33	16	18	80.0050.10.3810
G3/8	12	9	61	36	19	18	80.0050.10.3812

Material: nickel-plated brass

## 80.0050.04 SWIVEL ANGLE PUSH-IN FITTING

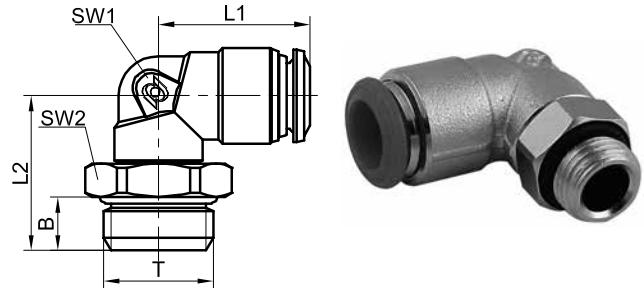

## 80.0050.05 ANGLE PUSH-IN FITTING WITH TAPERED THREAD

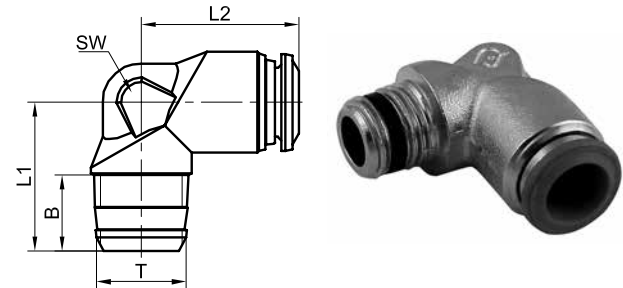

## 80.0050.06 ANGLE PUSH-IN FITTING EXTENDED SWIVEL

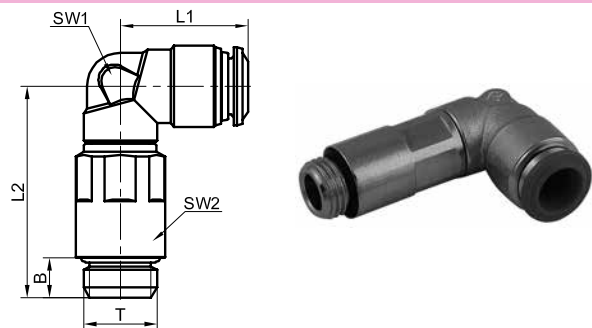

## 80.0050.10 T-PLUG SWIVEL CONNECTOR

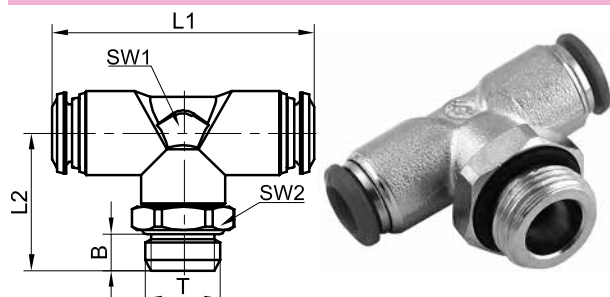

### 80.0050.14

PUSH-IN FITTINGS NOZZLE

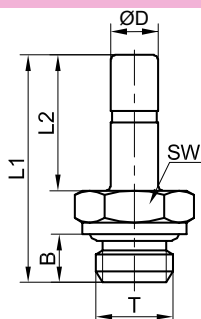

T	HOSE		B	L1	L2	SW	Order no.
	ØDz						
M5	4	4	24	15	8	80.0050.14.M504	
G1/8	4	6	27	15	13	80.0050.14.1804	
G1/8	6	6	29	17	13	80.0050.14.1806	
G1/8	8	6	30	18	13	80.0050.14.1808	
G1/4	6	7	31	17	16	80.0050.14.1406	
G1/4	8	8	32	18	16	80.0050.14.1408	
G1/4	10	8	36	22	16	80.0050.14.1410	
G1/4	12	8	39	24	16	80.0050.14.1412	
G3/8	8	9	34	18	20	80.0050.14.3808	
G3/8	10	9	38	22	20	80.0050.14.3810	
G3/8	12	9	40	24	20	80.0050.14.3812	

Material: nickel-plated brass

### 80.0050.07

PUSH-IN CONNECTOR

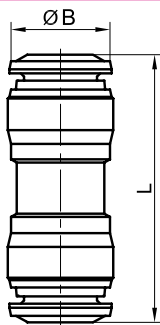

HOSE		B	L	Order no.
ØDz1	ØDz2			
4	4	12	30	80.0050.07.04
5	5	11	33	80.0050.07.05
6	4	13	32	80.0050.07.0604
6	6	13	34	80.0050.07.06
8	6	15	35	80.0050.07.0806
8	8	15	36	80.0050.07.08
10	10	18	42	80.0050.07.10
10	8	18	41	80.0050.07.1008
12	12	21	47	80.0050.07.12
12	10	21	46	80.0050.07.1210

Material: nickel-plated brass

### 80.0050.08

BULKHEAD PUSH-IN CONNECTOR

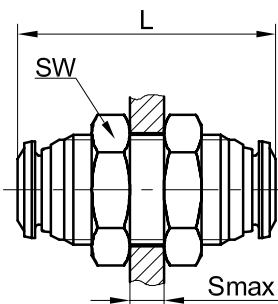

T	HOSE		L	Smax	SW	Order no.
	ØDz					
M12x1	4	32	7	17	80.0050.08.04	
M14x1	6	35	9.5	17	80.0050.08.06	
M16x1	8	37	10.5	19	80.0050.08.08	
M20x1	10	43	12.5	24	80.0050.08.10	
M22x1	12	48	16.5	26	80.0050.08.12	

Material: nickel-plated brass

### 80.0050.15

REDUCTION FOR PUSH-IN FITTINGS

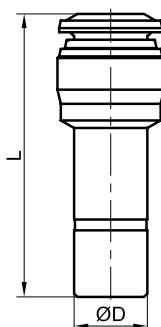

HOSE		ØD	L	Order no.
ØDz				
6	4	30	80.0050.15.0604	
8	4	33	80.0050.15.0804	
8	6	34	80.0050.15.0806	
10	4	32	80.0050.15.1004	
10	6	38	80.0050.15.1006	
10	8	38	80.0050.15.1008	
12	6	39	80.0050.15.1206	
12	8	39	80.0050.15.1208	
12	10	39	80.0050.15.1210	

Material: nickel-plated brass

HOSE ØDz	L	SW	Order no.
4	17	9	80.0050.09.04
6	21	11	80.0050.09.06
8	22	13	80.0050.09.08
10	27	16	80.0050.09.10
12	31	19	80.0050.09.12

Material: nickel-plated brass

### 80.0050.09

L TYPE PUSH-IN CONNECTOR

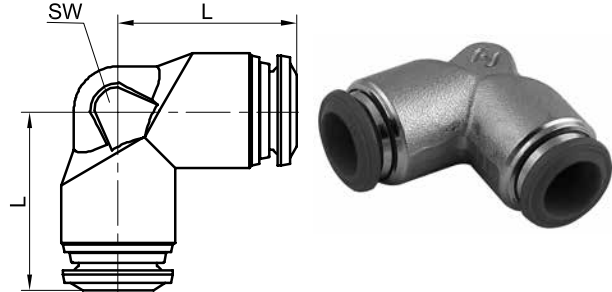

HOSE ØDz	L1	L2	SW	Order no.
4	34	17	9	80.0050.11.04
6	42	21	11	80.0050.11.06
8	45	23	13	80.0050.11.08
10	53	27	16	80.0050.11.10
12	61	31	19	80.0050.11.12

Material: nickel-plated brass

### 80.0050.11

T-PLUG CONNECTOR

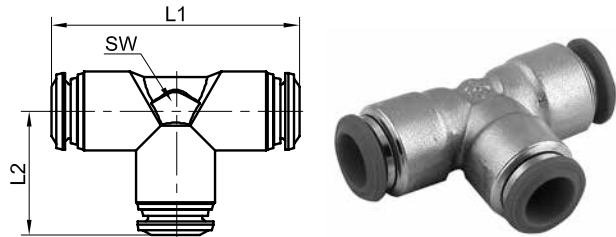

HOSE ØDz	F	L	Order no.
4	11	32	80.0050.12.04
6	14	37	80.0050.12.06
8	16	41	80.0050.12.08
10	16	55	80.0050.12.10
10	20	48	80.0050.12.10A
12	22	58	80.0050.12.12A

Material: nickel-plated brass

### 80.0050.12

Y-PLUG CONNECTOR

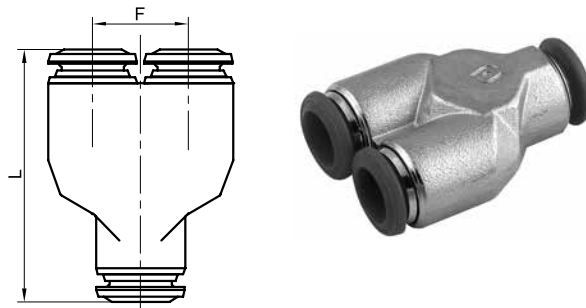

T	HOSE ØDz	C	H	L	L1	L2	Order no.
G1/8	4	15	25	75	12	13.5	80.0503.18.04
G1/8	6	15	25	90	14.5	16	80.0503.18.06
G1/4	6	20	30	90	14.5	16	80.0503.14.06
G1/4	8	20	30	100	16	18	80.0503.14.08

Material: aluminium

### 80.0503

5-WAY PUSH-IN MANIFOLD

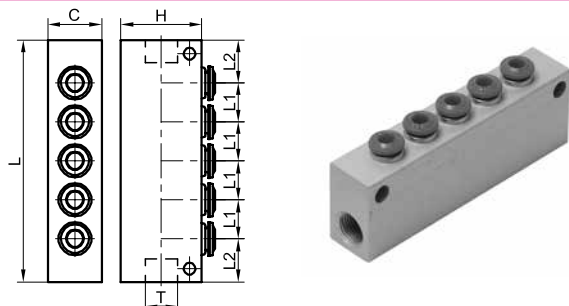

### 84.0050.01

STRAIGHT PUSH-IN FITTING

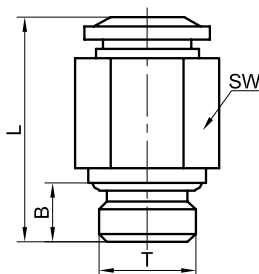

T	HOSE	B	L	SW	Order no.
	ØDz				
M5	4	4	19	10	84.0050.01.0504
M5	6	4	21	12	84.0050.01.0506
G1/8	4	5	19	14	84.0050.01.1804
G1/8	6	5	20	14	84.0050.01.1806
G1/8	8	5	26	14	84.0050.01.1808
G1/8	10	5	27	17	84.0050.01.1810
G1/4	4	7	18	17	84.0050.01.1404
G1/4	6	7	22	17	84.0050.01.1406
G1/4	8	7	24	17	84.0050.01.1408
G1/4	10	7	30	17	84.0050.01.1410
G1/4	12	7	32	21	84.0050.01.1412
G3/8	6	8	21	20	84.0050.01.3806
G3/8	8	8	21	20	84.0050.01.3808
G3/8	10	8	27	20	84.0050.01.3810
G3/8	12	8	30	21	84.0050.01.3812
G3/8	14	7	32	24	84.0050.01.3814
G3/8	16	7	34	24	84.0050.01.3816
G1/2	6	11	25	24	84.0050.01.1206
G1/2	8	11	26	24	84.0050.01.1208
G1/2	10	11	25	24	84.0050.01.1210
G1/2	12	11	32	24	84.0050.01.1212
G1/2	14	9	30	24	84.0050.01.1214
G1/2	16	11	38	24	84.0050.01.1216

Material: nickel-plated brass

### 84.0050.04

SWIVEL ANGLE PUSH-IN FITTING

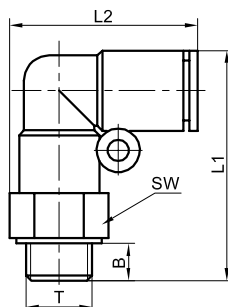

T	HOSE	B	L1	L2	SW	Order no.
	ØDz					
M5	4	4	22	23	8	84.0050.04.0504
M5	6	4	23	24	8	84.0050.04.0506
G1/8	4	5	25	30	14	84.0050.04.1804
G1/8	6	5	26	32	14	84.0050.04.1806
G1/8	8	5	30	36	14	84.0050.04.1808
G1/8	10	5	36	43	14	84.0050.04.1810
G1/4	4	7	26	32	17	84.0050.04.1404
G1/4	6	7	28	35	17	84.0050.04.1406
G1/4	8	7	32	39	17	84.0050.04.1408
G1/4	10	7	36	45	17	84.0050.04.1410
G1/4	12	7	42	48	21	84.0050.04.1412
G3/8	6	8	30	37	20	84.0050.04.3806
G3/8	8	8	34	40	20	84.0050.04.3808
G3/8	10	8	40	46	20	84.0050.04.3810
G3/8	12	8	41	50	21	84.0050.04.3812
G3/8	14	7	42	51	24	84.0050.04.3814
G3/8	16	7	46	55	24	84.0050.04.3816
G1/2	6	11	32	40	24	84.0050.04.1206
G1/2	8	11	36	44	24	84.0050.04.1208
G1/2	10	11	41	50	24	84.0050.04.1210
G1/2	12	11	42	53	24	84.0050.04.1212
G1/2	14	9	44	52	24	84.0050.04.1214
G1/2	16	11	45	58	24	84.0050.04.1216

Material: nylon and polyurethane

### 84.0050.08

BULKHEAD PUSH-IN CONNECTOR

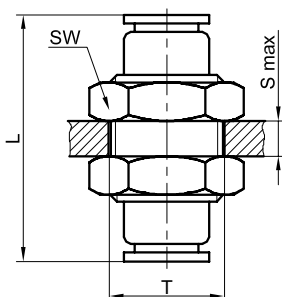

T	HOSE	Smax.	L	SW	Order no.
	ØDz				
M12	4	9.7	30	14	84.0050.08.04
M14	6	7.5	32	17	84.0050.08.06
M16	8	6.8	35	19	84.0050.08.08
M20	10	11.5	39	24	84.0050.08.10
M22	12	12.8	45	27	84.0050.08.12
M24	14	19	45	27	84.0050.08.14
M26	16	21.6	47	30	84.0050.08.16

Material: nickel-plated brass

T	HOSE	B	L1	L2	SW	Order no.
	ØDz					
G1/8	4	5	26	41	14	84.0050.06.1804
G1/8	6	5	27	46	14	84.0050.06.1806
G1/8	8	5	30	52	14	84.0050.06.1808
G1/4	4	7	28	45	17	84.0050.06.1404
G1/4	6	7	29	49	17	84.0050.06.1406
G1/4	8	7	31	55	17	84.0050.06.1408
G1/4	10	7	39	65	17	84.0050.06.1410
G3/8	6	8	30	50	20	84.0050.06.3806
G3/8	8	8	34	56	20	84.0050.06.3808
G3/8	10	8	39	65	20	84.0050.06.3810
G3/8	12	8	42	73	20	84.0050.06.3812
G1/2	10	11	41	70	24	84.0050.06.1210
G1/2	12	11	43	76	24	84.0050.06.1212

Material: nylon and polyurethane

## 84.0050.06

ANGLE PUSH-IN FITTING EXTENDED SWIVEL

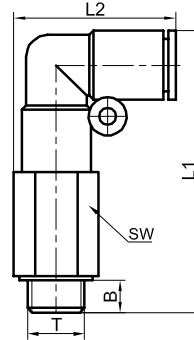

T	HOSE	B	F	L1	L2	SW	Order no.
	ØDz						
G1/8	4	5	13.7	37	31	14	84.0050.10.1804
G1/8	6	5	15.7	39	33	14	84.0050.10.1806
G1/8	8	5	17.5	45	37	14	84.0050.10.1808
G1/8	10	5	23.7	55	44	17	84.0050.10.1810
G1/4	6	7	15.8	38	35	17	84.0050.10.1406
G1/4	8	7	17.3	45	39	17	84.0050.10.1408
G1/4	10	7	23.7	55	46	17	84.0050.10.1410
G1/4	12	7	26.6	59	49	17	84.0050.10.1412
G3/8	6	8	15.8	38	37	20	84.0050.10.3806
G3/8	8	8	17.4	45	40	20	84.0050.10.1208
G3/8	10	8	23.3	55	47	20	84.0050.10.3810
G3/8	12	8	26.4	58	50	20	84.0050.10.3812
G3/8	14	7	30.3	62	52	24	84.0050.10.3814
G3/8	16	7	30.3	66	54	24	84.0050.10.3816
G1/2	6	9	15.2	39	38	24	84.0050.10.1206
G1/2	8	9	17.2	45	40	24	84.0050.10.3809
G1/2	10	11	23.7	55	51	24	84.0050.10.1210
G1/2	12	11	26.6	58	54	24	84.0050.10.1212
G1/2	14	9	30.3	62	53	24	84.0050.10.1214
G1/2	16	9	30.3	66	55	24	84.0050.10.1216

Material: nylon and polyurethane

## 84.0050.10

T-PLUG SWIVEL CONNECTOR

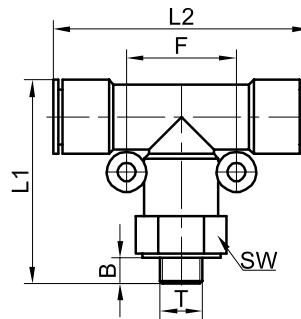

T	HOSE	Ød	B	L	SW	Order no.
	ØDz					
G1/8	4	3.2	5	42	10	84.0050.17.1804
G1/8	6	3.2	5	44	14	84.0050.17.1806
G1/8	8	3.2	5	46	14	84.0050.17.1808
G1/8	10	4.3	5	56	17	84.0050.17.1810
G1/4	4	3.2	7	44	10	84.0050.17.1404
G1/4	6	3.2	7	46	17	84.0050.17.1406
G1/4	8	3.2	7	48	17	84.0050.17.1408
G1/4	10	4.3	7	58	17	84.0050.17.1410
G1/4	12	4.3	7	60	19	84.0050.17.1412
G3/8	6	3.2	8	47	20	84.0050.17.3806
G3/8	8	3.2	8	50	20	84.0050.17.3808
G3/8	10	4.3	8	58	20	84.0050.17.3810
G3/8	12	4.3	7	61	21	84.0050.17.3812
G1/2	6	3.2	9	46	24	84.0050.17.1206
G1/2	8	3.2	11	54	24	84.0050.17.1208
G1/2	10	4.3	11	62	24	84.0050.17.1210
G1/2	12	4.3	9	62	24	84.0050.17.1212

Material: nylon and polyurethane

## 84.0050.17

Y-PLUG CONNECTOR

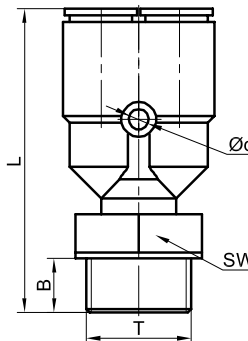



### 84.0050.07

STRAIGHT PUSH-IN CONNECTOR

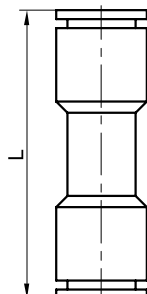

HOSE ØDz	L	Order no.
4	33	84.0050.07.04
5	34	84.0050.07.05
6	35	84.0050.07.06
7	38	84.0050.07.07
8	38	84.0050.07.08
10	48	84.0050.07.10
12	49	84.0050.07.12
14	53	84.0050.07.14
15	64	84.0050.07.15
16	50	84.0050.07.16

Material: nylon and polyurethane

### 84.0050.19

STRAIGHT PUSH-IN REDUCING CONNECTOR

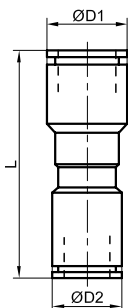

HOSE		ØD1	ØD2	L	Order no.
ØDz1	ØDz2				
6	4	12	10	35	84.0050.19.0604
8	4	13	10	40	84.0050.19.0804
8	6	13	12	35	84.0050.19.0806
10	8	17	13	40	84.0050.19.1008
12	10	18	17	49	84.0050.19.1210
12	16	18	24	49	84.0050.19.1216
16	14	24	21	54	84.0050.19.1614

Material: nylon and polyurethane

### 84.0050.15

STRAIGHT PUSH-IN REDUCER

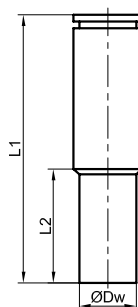

HOSE		L1	L2	Order no.
ØDz	ØDw			
4	6	39	16	84.0050.15.0604
6	8	42	17	84.0050.15.0806
8	10	47	20	84.0050.15.1008
10	12	52	22	84.0050.15.1210

Material: nylon and polyurethane

### 84.0050.09

L TYPE ANGLE PUSH-IN CONNECTOR

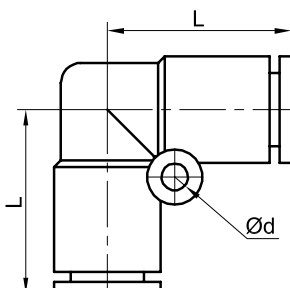

HOSE ØDz	Ød	L	Order no.
4	3.2	18	84.0050.09.04
6	3.2	19	84.0050.09.06
8	3.2	23	84.0050.09.08
10	4.3	28	84.0050.09.10
12	4.3	30	84.0050.09.12
14	4.3	31	84.0050.09.14
16	4.3	32	84.0050.09.16

Material: nylon and polyurethane

HOSE		Ød	F	L	Order no.
ØDz1	ØDz2				
4	4	3.2	14	19	84.0050.11.04
6	6	3.2	15	19	84.0050.11.06
6	4	3.2	15	19	84.0050.11.0604
8	8	3.2	18	22	84.0050.11.08
8	6	3.2	18	22	84.0050.11.0806
10	10	4.3	23	28	84.0050.11.10
10	8	4.3	23	28	84.0050.11.1008
12	12	4.3	25	28	84.0050.11.12
12	10	4.3	25	28	84.0050.11.1210
14	14	5.3	30	31	84.0050.11.14
16	16	5.3	30	32	84.0050.11.16

Material: nylon and polyurethane

### 84.0050.11

T-PLUG REDUCTION CONNECTOR

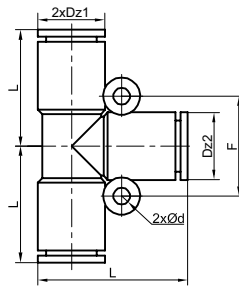

HOSE		Ød	F	L	Order no.
ØDz1	ØDz2				
6	4	3.2	15	19	84.0050.21.0604
8	6	3.2	18	22	84.0050.21.0806
10	8	4.3	23	26	84.0050.21.1008
12	10	4.3	25	27	84.0050.21.1210
16	12	5.3	30	33	84.0050.21.1612

Material: nylon and polyurethane

### 84.0050.21

T-PLUG REDUCTION CONNECTOR

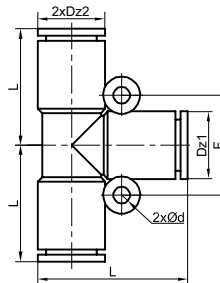

HOSE	Ød	F	L	Order no.
ØDz				
4	3.2	14	36	84.0050.12.04
6	3.2	15	37	84.0050.12.06
8	3.2	18	40	84.0050.12.08
10	4.3	21	50	84.0050.12.10
12	4.3	21	52	84.0050.12.12
14	4.3	25	57	84.0050.12.14

Material: nylon and polyurethane

### 84.0050.12

Y-PLUG CONNECTOR

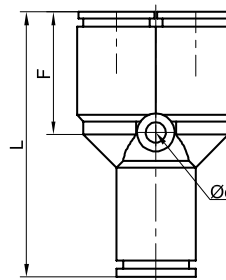

HOSE		Ød	F	L	Order no.
ØDz1	ØDz2				
6	4	3.2	14	37	84.0050.16.0604
8	6	3.2	17	40	84.0050.16.0806
10	8	4.3	20	48	84.0050.16.1008
12	10	4.3	21	52	84.0050.16.1210

Material: nylon and polyurethane

### 84.0050.16

Y-PLUG REDUCTION CONNECTOR

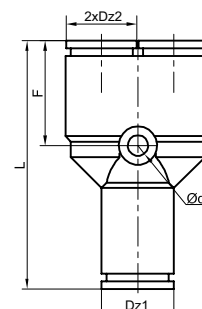

### 84.0050.18

FOUR-WAY PUSH-IN CONNECTOR

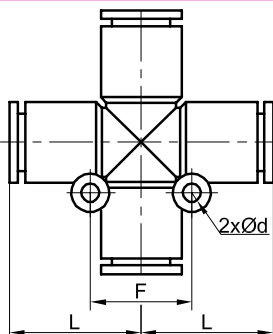

HOSE ØDz	Ød	F	L	Order no.
4	3.2	13.7	18	84.0050.18.04
6	3.2	15.7	19	84.0050.18.06
8	3.2	17.5	23	84.0050.18.08
10	4.3	23.7	28	84.0050.18.10
12	4.3	26.6	30	84.0050.18.12

Material: nylon and polyurethane

### 84.0303

PUSH-IN MANIFOLD

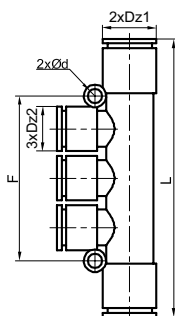

HOSE		Ød	F	L	Order no.
ØDz1	ØDz2				
6	4	3.2	36	57	84.0303.0604
8	4	3.2	42	62	84.0303.0804
8	6	3.2	42	62	84.0303.0806
10	6	4.3	47	81	84.0303.1008
10	8	4.3	47	81	84.0303.1007

Material: nylon and polyurethane

### 81.0050.01

STRAIGHT PUSH-IN FITTING

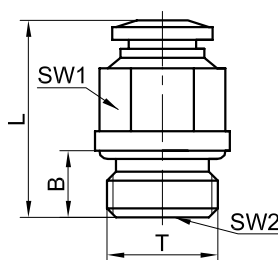

T	HOSE ØDz	B	L	SW1	SW2	Order no.
G1/8	4	6	20	10	3	81.0050.01.1804
G1/8	6	6	24	13	4	81.0050.01.1806
G1/8	8	6	26	14	5	81.0050.01.1808
G1/4	6	8	24	15	4	81.0050.01.1406
G1/4	8	8	24	15	6	81.0050.01.1408
G1/4	10	8	30	17	8	81.0050.01.1410
G3/8	10	9	27	17	8	81.0050.01.3810
G3/8	12	9	34	21	8	81.0050.01.3812
G1/2	12	10	31	22	10	81.0050.01.1212

Material: stainless steel

### 81.0050.04

SWIVEL ANGLE PUSH-IN FITTING

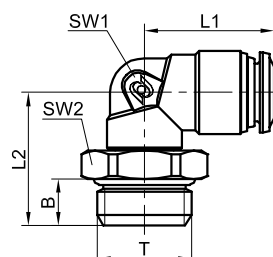

T	HOSE ØDz	B	L1	L2	SW1	SW2	Order no.
G1/8	4	6	17	23	18	17	81.0050.04.1804
G1/8	6	6	21	25	21	19	81.0050.04.1806
G1/8	8	6	23	26	23	20	81.0050.04.1808
G1/4	6	8	21	21	11	15	81.0050.04.1406
G1/4	8	8	23	29	23	22	81.0050.04.1408
G1/4	10	8	27	31	26	23	81.0050.04.1410
G3/8	10	9	27	33	16	21	81.0050.04.3810
G3/8	12	9	31	36	19	21	81.0050.04.3812
G1/2	10	10	27	34	16	22	81.0050.04.1210

Material: stainless steel

HOSE ØDz	ØD	L	Order no.
4	11	31	81.0050.07.04
6	13	35	81.0050.07.06
8	15	37	81.0050.07.08
10	18	42	81.0050.07.10
12	21	48	81.0050.07.12

Material: stainless steel ASI 316L

### 81.0050.07

#### STRAIGHT PUSH-IN CONNECTOR

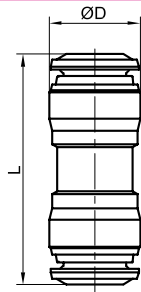

T	HOSE ØDz	Smax	L	SW	Order no.
M14x1	6	9.5	35	17	81.0050.08.06
M16x1	8	10.5	37	19	81.0050.08.08
M20x1	10	12.5	42	24	81.0050.08.10
M22x1	12	16.5	48	26	81.0050.08.12

Material: stainless steel ASI 316L

### 81.0050.08

#### BULKHEAD PUSH-IN CONNECTOR

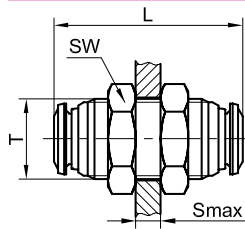

HOSE ØDz	ØD	L1	L2	SW	Order no.
4	10	36	18	9	81.0050.11.04
6	13	42	21	11	81.0050.11.06
8	15	45	23	12	81.0050.11.08
10	18	52	26	16	81.0050.11.10
12	21	61	31	19	81.0050.11.12

Material: stainless steel ASI 316L

### 81.0050.11

#### T TYPE PUSH-IN CONNECTOR

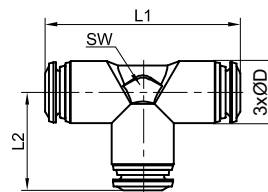

ØD1	ØD2	ØD3	L1	L2	Order no.
4	5	3	28	15	84.8610.04
6	7	3	33	17	84.8610.06
8	9	4	37	18	84.8610.08
10	11	5	42	20	84.8610.10
12	13	6	44	23	84.8610.12

Material: polyacetal

### 84.8610

#### END CAP FOR PUSH-IN CONNECTORS

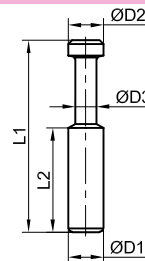

HOSE ØD	L	Order no.
4	24	80.8610.04
6	25	80.8610.06
8	26	80.8610.08
10	29	80.8610.10
12	31	80.8610.12

Material: polyamide

### 80.8610

#### END CAP FOR PUSH-IN CONNECTORS

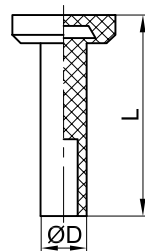

### TECHNICAL SPECIFICATIONS

<b>Maximum operating pressure:</b>	10 bar
<b>Medium:</b>	compressed air or other non-aggressive gas, non-aggressive liquids
<b>Operating temperature range:</b>	0 to +80°C
<b>Minimum opening pressure of the check valve</b>	0.15 bar
<b>Materials:</b>	
<b>Body</b>	- nickel-plated brass / OT 58 UNI 5705
<b>Choke</b>	- nickel-plated brass / OT 58 UNI 5705
<b>Lock nut</b>	- nickel-plated brass / OT 58 UNI 5705
<b>Knob</b>	- nickel-plated brass / OT 58 UNI 5705
<b>Sealing rings</b>	- NBR 70
<b>Lip seal</b>	- NBR 70
<b>Gasket fixing</b>	- nickel-plated brass / OT 58 UNI 5705
<b>Gasket washer</b>	- PA66

#### MANUAL ADJUSTMENT (TYPE II)

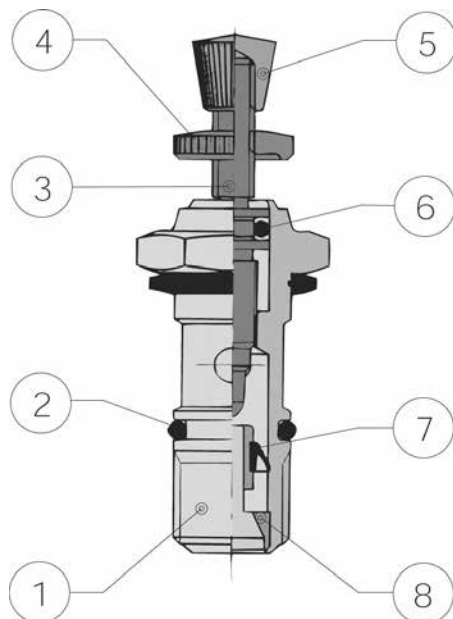

#### SCREWDRIVER ADJUSTMENT (TYPE I)

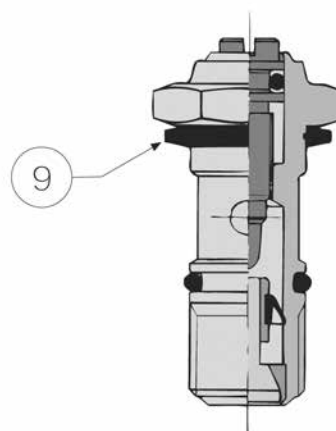

- 1) Body, 2) Sealing ring, 3) Throttle, 4) Lock nut, 5) Knob, 6) Sealing ring, 7) Lip seal, 8) Seal fixing, 9) Gasket washer

Throttle and throttle-check valves are used in pneumatic systems to control the flow rate of compressed air. This allows for a stepless adjustment of the actuator speed. The screw-in throttle and throttle-check valves can be mounted directly into the actuator connection. The throttle-check valves enable the free flow of the working medium in one direction and control of the flow rate of this medium in the opposite direction. The valves are made in four versions:

- with hose fitting with nut,
- with a push-in hose fitting,
- with female thread,
- with integrated hose.

These grades are equipped with a control throttle with a spanner cut-out (type I) or with a knob for manual adjustment (type II).

T	HOSE	B	L1	L2	SW	Order no.
	ØDz					
M5	4	4	24	20	8	80.5091.M5.04
M5	6	4	24	20	8	80.5091.M5.06
G1/8	4	5	31	23	14	80.5091.18.04
G1/8	6	5	31	23	14	80.5091.18.06
G1/8	8	5	31	25	14	80.5091.18.08
G1/4	6	8	36	25	17	80.5091.14.06
G1/4	8	8	36	27	17	80.5091.14.08
G1/4	10	8	36	30	17	80.5091.14.10
G3/8	8	9	36	28	20	80.5091.38.08
G3/8	10	9	36	31	20	80.5091.38.10
G3/8	12	9	36	33	20	80.5091.38.12
G1/2	12	10	36	35	24	80.5091.12.12

Material: nickel-plated brass

### 80.5091

SCREW-IN THROTTLE VALVE WITH A PUSH-IN FITTING FOR PLASTIC HOSES TYPE I

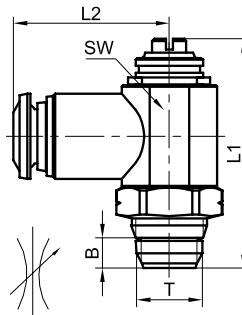

T	HOSE	B	L1min	L1max	L2	SW	Order no.
	ØDz						
M5	4	4	31	35	20	8	80.5092.M5.04
G1/8	4	5	40	45	23	14	80.5092.18.04
G1/8	6	5	40	45	23	14	80.5092.18.06
G1/8	8	5	40	45	25	14	80.5092.18.08
G1/4	6	8	46	52	25	17	80.5092.14.06
G1/4	8	8	46	52	27	17	80.5092.14.08
G1/4	10	8	46	52	30	17	80.5092.14.10

Material: nickel-plated brass

### 80.5092

SCREW-IN THROTTLE VALVE WITH A PUSH-IN FITTING FOR PLASTIC HOSES TYPE II

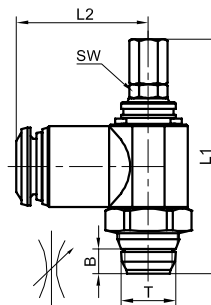

T	HOSE	B	L1	L2	SW	Order no.
	ØDz					
M5	4	4	24	20	8	80.5081.M5.04
M5	6	4	24	20	8	80.5081.M5.06
G1/8	4	5	31	23	14	80.5081.18.04
G1/8	6	5	31	23	14	80.5081.18.06
G1/8	8	5	31	25	14	80.5081.18.08
G1/4	6	8	36	25	17	80.5081.14.06
G1/4	8	8	36	27	17	80.5081.14.08
G1/4	10	8	36	30	17	80.5081.14.10
G3/8	8	9	36	28	20	80.5081.38.08
G3/8	10	9	36	31	20	80.5081.38.10
G3/8	12	9	36	33	20	80.5081.38.12
G1/2	12	10	36	35	24	80.5081.12.12

Material: nickel-plated brass

### 80.5081

SCREW-IN THROTTLE-CHECK VALVE A WITH PUSH-IN FITTING FOR PLASTIC HOSES TYPE I

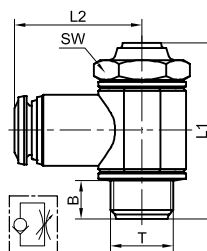

T	HOSE	B	L1min	L1max	L2	SW	Order no.
	ØDz						
M5	4	4	31	35	20	8	80.5082.M5.04
G1/8	4	5	40	45	23	14	80.5082.18.04
G1/8	6	5	40	45	23	14	80.5082.18.06
G1/8	8	5	40	45	25	14	80.5082.18.08
G1/4	6	8	46	52	25	17	80.5082.14.06
G1/4	8	8	46	52	27	17	80.5082.14.08
G1/4	10	8	46	52	30	17	80.5082.14.10

Material: nickel-plated brass

### 80.5082

SCREW-IN THROTTLE-CHECK VALVE A WITH PUSH-IN FITTING FOR PLASTIC HOSES TYPE II

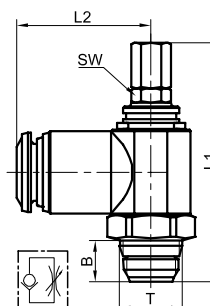

### 84.5082

SCREW-IN THROTTLE-CHECK VALVE A WITH PUSH-IN FITTING FOR PLASTIC HOSES TYPE II

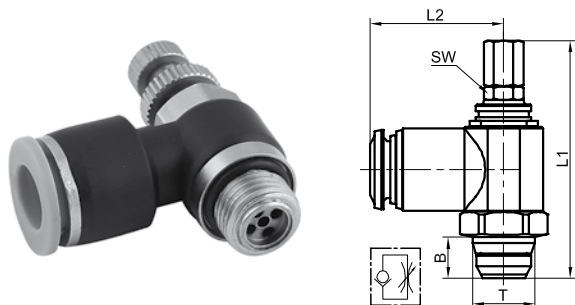

T	HOSE ØDz	B	L1	L2	SW	Order no.
M5	4	4	20	28	8	84.5082.0504
M5	6	4	20	27	8	84.5082.0506
G1/8	4	5	22	35	10	84.5082.1804
G1/8	6	6	22	35	10	84.5082.1806
G1/8	8	6	24	36	10	84.5082.1808
G1/8	10	5	30	36	10	84.5082.1810
G1/4	4	8	24	42	14	84.5082.1404
G1/4	6	8	24	42	14	84.5082.1406
G1/4	8	8	27	42	14	84.5082.1408
G1/4	10	8	30	42	14	84.5082.1410
G1/4	12	12	34	42	14	84.5082.1412
G3/8	6	9	26	48	19	84.5082.3806
G3/8	8	9	29	49	19	84.5082.3808
G3/8	10	9	33	47	19	84.5082.3810
G3/8	12	9	35	49	19	84.5082.3812
G1/2	6	12	30	52	24	84.5082.1206
G1/2	8	12	33	52	24	84.5082.1208
G1/2	10	12	34	51	24	84.5082.1210
G1/2	12	12	37	51	24	84.5082.1212

Material: nylon and polyurethane

### 84.5000

THROTTLE-CHECK VALVE WITH A PUSH-IN FITTING FOR PLASTIC HOSES TYPE II

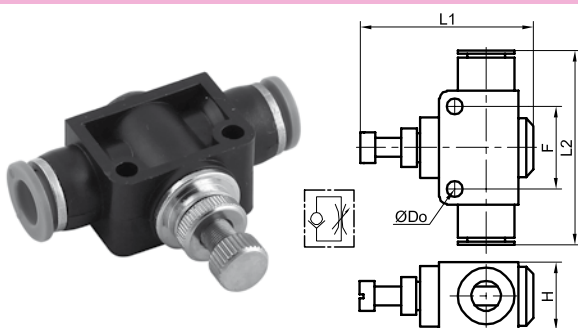

HOSE ØDz	ØDo	F	H	L1	L2	Order no.
4	3.2	14	11	27	39	84.5000.04
6	4.3	20	14	39	47	84.5000.06
8	4.3	22	18	40	52	84.5000.08
10	4.3	26	21	48	62	84.5000.10
12	4.3	32	27	51	74	84.5000.12

Material: nylon and polyurethane

### 84.5001

CUT-OFF VALVE WITH PUSH-IN FITTING FOR PLASTIC HOSES WITH VENTING

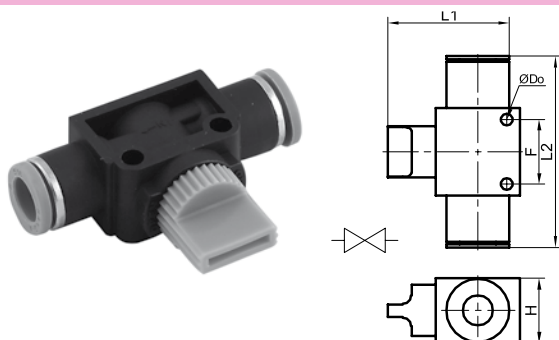

HOSE ØDz	ØDo	F	H	L1	L2	Order no.
6	4.2	17	18	41	52	84.5001.06
8	4.2	17	18	41	52	84.5001.08
10	4.2	21	22	45	63	84.5001.10
12	4.2	22	22	45	61	84.5001.12

Material: nylon and polyurethane

### 84.5002

CUT-OFF VALVE WITH PUSH-IN FITTING



HOSE ØDz	H	L1	L2	Order no.
6	18	32	55	84.5002.06
8	17	32	58	84.5002.08
10	24	41	74	84.5002.10
12	24	41	80	84.5002.12

Material: nylon and polyurethane

T	HOSE		B	L1	L2	SW	Order no.
	ØDz	ØDw					
M5	4	2	4	24	18	8	80.5091.05.0402
M5	6	4	4	24	17	8	80.5091.05.0604
M5	6	-	4	24	20	8	80.5091.M5.06
G1/8	4	2	5	31	20	8	80.5091.18.0402
G1/8	6	4	5	31	23	14	80.5091.18.0604
G1/8	8	6	5	31	25	14	80.5091.18.0806
G1/4	6	4	8	36	25	17	80.5091.14.0604
G1/4	8	6	8	36	28	17	80.5091.14.0806
G1/4	10	8	8	36	30	17	80.5091.14.1008
G3/8	8	6	9	41	28	20	80.5091.34.0806
G3/8	10	8	9	41	31	20	80.5091.34.1008

Material: nickel-plated brass

### 80.5091

THROTTLE VALVE FOR PLASTIC HOSES TYPE I

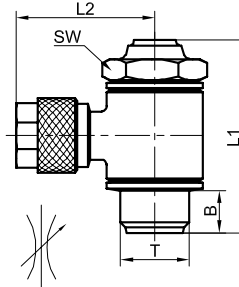

T	HOSE		B	ØD	L1min	L1max	L2	SW	Order no.
	ØDz	ØDw							
M5	6	4	4	12	31	35	16	8	80.5092.05.0604
G1/8	6	4	5	12	40	45	23	14	80.5092.18.0604
G1/8	8	6	5	14	40	45	25	14	80.5092.18.0806
G1/4	6	4	8	12	46	52	25	17	80.5092.14.0604
G1/4	8	6	8	14	46	52	28	17	80.5092.14.0806
G1/4	10	8	8	16	46	52	30	17	80.5092.14.1008

Material: nickel-plated brass

### 80.5092

THROTTLE VALVE FOR PLASTIC HOSES TYPE II

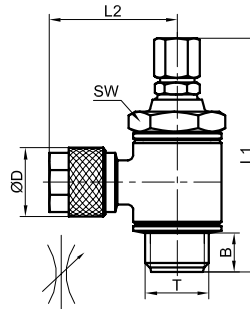

T	HOSE		B	ØD	L1	L2	SW	Order no.
	ØDz	ØDw						
M5	6	4	4	12	24	17	8	80.5081.05.0604
G1/8	6	4	5	12	31	24	14	80.5081.18.0604
G1/8	8	6	5	14	31	25	14	80.5081.18.0806
G1/4	6	4	8	12	36	25	17	80.5081.14.0604
G1/4	8	6	8	14	36	28	17	80.5081.14.0806
G1/4	10	8	8	16	36	30	17	80.5081.14.1008
G3/8	8	6	9	14	41	28	20	80.5081.38.0806
G3/8	10	8	9	16	41	31	20	80.5081.38.1008

Material: nickel-plated brass

### 80.5081

THROTTLE-CHECK VALVE FOR PLASTIC HOSES TYPE I

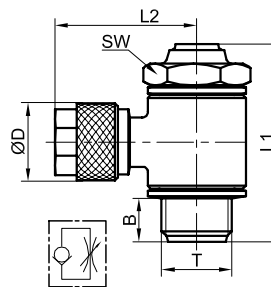

T	HOSE		B	ØD	L1min	L1max	L2	SW	Order no.
	ØDz	ØDw							
M5	4	2	4	10	34	38	19	8	80.5082.05.0402
M5	6	4	4	12	31	35	71	8	80.5082.05.0604
G1/8	6	4	5	12	40	45	23	14	80.5082.18.0604
G1/8	8	6	5	14	40	45	25	14	80.5082.18.0806
G1/4	6	4	8	12	46	52	25	17	80.5082.14.0604
G1/4	8	6	8	14	46	52	28	17	80.5082.14.0806
G1/4	10	8	8	16	46	52	30	17	80.5082.14.1008

Material: nickel-plated brass

### 80.5082

THROTTLE-CHECK VALVE FOR PLASTIC HOSES TYPE II

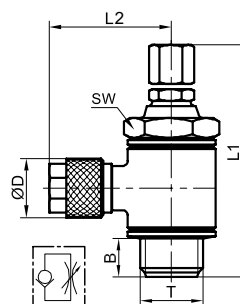



### 80.5091

THROTTLE VALVE WITH THREAD TYPE I

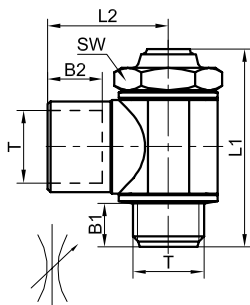

T	B1	B2	L1	L2	SW	Order no.
G1/8	5	8	31	16	14	80.5091.18.18
G1/4	8	10	36	22	17	80.5091.14.14
G3/8	9	12	36	26	20	80.5091.38.38

Material: nickel-plated brass

### 80.5092

THROTTLE VALVE WITH THREAD TYPE II

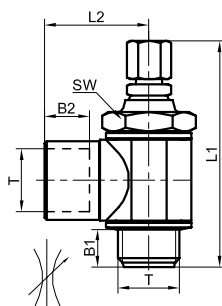

T	B1	B2	L1min	L1max	L2	SW	Order no.
G1/8	5	8	40	45	16	14	80.5092.18.18
G1/4	8	11	46	52	22	17	80.5092.14.14

Material: nickel-plated brass

### 80.5081

THROTTLE-CHECK VALVE WITH THREAD TYPE I

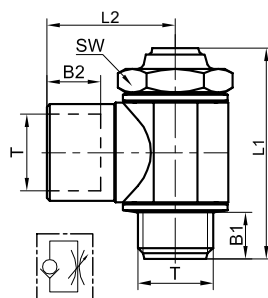

T	B1	B2	L1	L2	SW	Order no.
G1/8	5	7	31	16	14	80.5081.18.18
G1/4	8	10	36	22	17	80.5081.14.14
G3/8	9	12	36	26	20	80.5081.38.38

Material: nickel-plated brass

### 80.5082

THREADED THROTTLE-CHECK VALVE TYPE II

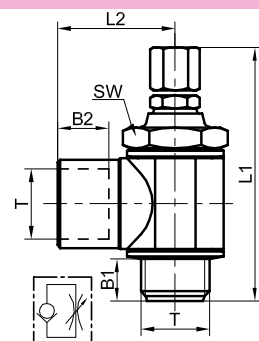

T	B1	B2	L1max	L1min	L2	SW	Order no.
G1/8	5	8	45	40	16	14	80.5082.18.18
G1/4	8	10	52	46	22	17	80.5082.14.14

Material: nickel-plated brass

HOSE ØDz	ØD	L	Order no.
4	10	31	80.5002.0404
6	13	35	80.5002.0606
8	14	37	80.5002.0808

Material: nickel-plated brass

### 80.5002 PUSH-IN CHECK VALVE

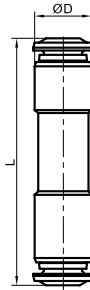

T	B1	B2	L	SW	Order no.
M5	5	4	35	8	80.5002.M5-A
G1/8	5	6	38	14	80.5002.18-A
G1/4	11	8	47	17	80.5002.14-A
G3/8	12	9	61	24	80.5002.38-A
G1/2	15	10	64	24	80.5002.12-A

Material: nickel-plated brass

### 80.5002 CHECK VALVE THREAD WZ

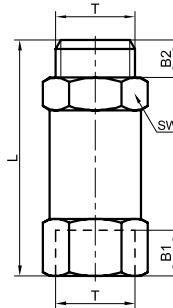

T	B	L	SW	Order no.
M5	5	27	8	80.5002.M5-AW
G1/8	8	36	14	80.5002.18-AW
G1/4	11	43	17	80.5002.14-AW
G3/8	12	58	24	80.5002.38-AW
G1/2	15	63	24	80.5002.12-AW

Material: nickel-plated brass

### 80.5002 CHECK VALVE FEMALE THREAD

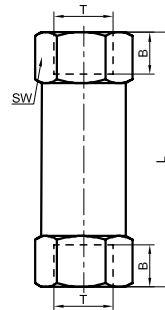

T	L	SW	Order no.
G1/4	53	19	85.0227.14
G3/8	54	19	85.0227.38
G1/2	63	24	85.0227.12
G3/4	58	36	85.0227.34
G1	68.5	46	85.0227.100

Material: brass

### 85.0227 CHECK VALVE

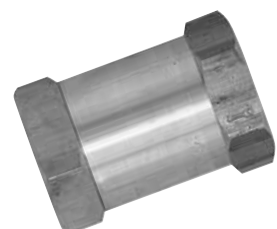
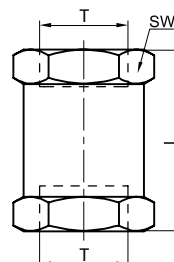

### 80.6060

CUT-OFF  
VALVE WITH VENTING

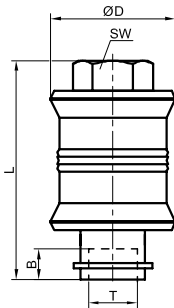

T	B	ØD	L	SW	Order no.
G1/8	10	25	48	14	80.6060.18
G1/4	14	30	58	17	80.6060.14
G3/8	14	35	68	22	80.6060.38
G1/2	16	40	80	27	80.6060.12

Material: nickel-plated brass / aluminium

### TECHNICAL SPECIFICATIONS

<b>Maximum operating pressure:</b>	15 bar
<b>Medium:</b>	compressed air or other non-aggressive gas, non-aggressive liquids
<b>Operating temperature range:</b>	-18 to +70°C
<b>Materials:</b>	
<b>Nut</b>	- nickel-plated brass, aluminium or plastic / OT58 UNI 5705
<b>Body</b>	- nickel-plated brass, aluminium or plastic / OT58 UNI 5705

#### NORMAL FITTING

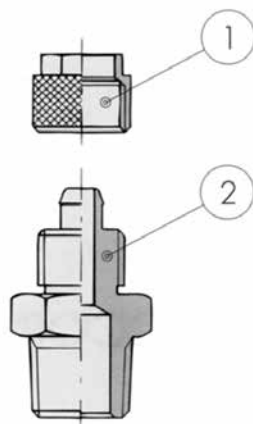

#### SWIVEL FITTINGS

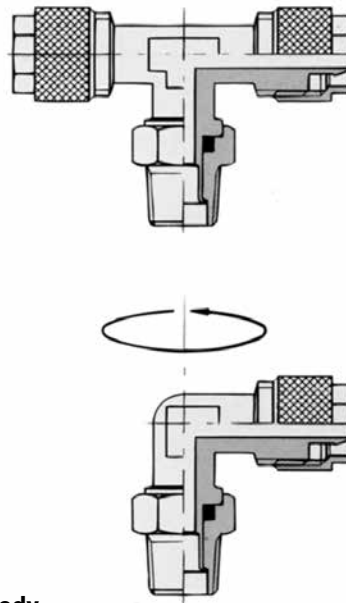

1) Nut, 2) Body

### ATTACHING THE HOSE

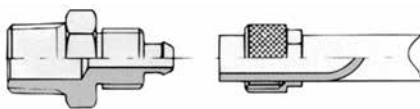

- put a nut on the hose

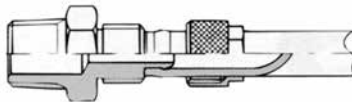

- put the hose on the end of the fitting

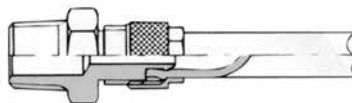

- tighten the nut by hand or with a spanner

Plastic hose fittings are used to connect hoses and pneumatic components in pneumatic control and actuation systems. Simple construction and high quality of workmanship guarantee easy and fast connection of hoses. The tightness of the connection is ensured by the proper shape of the end of the fitting and the fastening nut. The fittings are used to connect hoses made of the following types of plastics:

- polyamide,
- polyethylene,
- reinforced PVC,
- RILSAN,
- polyurethane.

### 60.0001

STRAIGHT FITTING

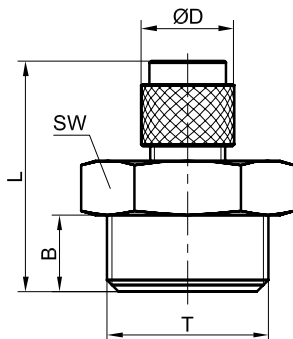

T	HOSE		B	ØD	L	SW	Order no.
	ØDz	ØDw					
M5	6	4	4	9	21.5	8	60.0001.05.0601
G1/8	6	4	6	12	24	13	60.0001.18.0601
G1/8	8	6	6	14	26	14	60.0001.18.0801
G1/8	10	8	6	16	28	14	60.0001.18.1001
G1/4	6	4	8	12	27	17	60.0001.14.0601
G1/4	8	6	8	14	28	17	60.0001.14.0801
G1/4	10	8	8	16	30	17	60.0001.14.1001
* G1/4	12	8	8	19	31	17	60.0001.14.1202
G3/8	6	4	9	12	28	19	60.0001.38.0601
G3/8	8	6	9	14	29	19	60.0001.38.0801
G3/8	10	8	9	16	31	19	60.0001.38.1001
* G3/8	12	8	10	19	34	22	60.0001.38.1202
* G3/8	16	12	10	25	39	22	60.0001.38.1602
G1/2	6	4	10	12	30	24	60.0001.12.0601
G1/2	8	6	10	14	30	24	60.0001.12.0801
G1/2	10	8	10	16	33	24	60.0001.12.1001
* G1/2	12	8	10	19	34	27	60.0001.12.1202
* G1/2	14	12	10	25	39	27	60.0001.12.1602
* G1/2	20	16	10	28	39	27	60.0001.12.2002
* G3/4	10	8	14	19	40	32	60.0001.34.1001
* G3/4	12	8	14	19	40	32	60.0001.34.1202
* G3/4	16	12	14	25	44	32	60.0001.34.1602
* G3/4	20	16	14	28	44	32	60.0001.34.2002

Material: nickel-plated brass

\* version – Aluminium

### 80.0010

STRAIGHT FITTING

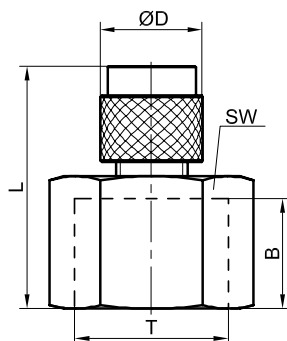

T	HOSE		B	ØD	L	SW	Order no.
	ØDz	ØDw					
G1/8	6	4	7	12	54	14	80.0010.18.0601
G1/8	8	6	7	14	25	14	80.0010.18.0801
G1/4	6	4	11	12	27	17	80.0010.14.0601
G1/4	8	6	11	14	29	17	80.0010.14.0801
G1/4	10	8	11	16	30	17	80.0010.14.1001
G3/8	6	4	11	12	28	22	80.0010.38.0601
G3/8	8	6	11	14	30	22	80.0010.38.0801
G3/8	10	8	11	16	33	22	80.0010.38.1001
G1/2	8	6	15	14	33	24	80.0010.12.0801
G1/2	10	8	15	16	35	24	80.0010.12.1001

Material: nickel-plated brass

### 80.0059

STRAIGHT FITTING WITH HOSE  
KINK PROTECTION

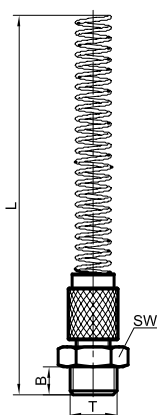

T	HOSE		B	L	SW	Order no.
	ØDz	ØDw				
G1/8	6	4	6	106	13	80.0059.18.0604
G1/8	8	6	6	112	14	80.0059.18.0806
G1/8	10	8	6	120	14	80.0059.18.1008
G1/4	6	4	8	110	17	80.0059.14.0604
G1/4	8	6	8	115	17	80.0059.14.0806
G1/4	10	8	8	120	17	80.0059.14.1008
G3/8	8	6	9	115	19	80.0059.38.0806
G3/8	10	8	9	124	19	80.0059.38.1008
G1/2	10	8	10	124	24	80.0059.12.1008

Material: nickel-plated brass

T	HOSE		B	ØD	L1	L2	SW1	SW2	Order no.
	ØDz	ØDw							
G1/8	6	4	6	13	21	20	8	14	80.0057.18.0604
G1/8	8	6	6	13	21	20	9	14	80.0057.18.0806
G1/4	6	4	8	17	21	22	8	17	80.0057.14.0604
G1/4	8	6	8	17	24	23	9	17	80.0057.14.0806
G1/4	10	8	8	17	24	24	11	17	80.0057.14.1008

Material: nickel-plated brass

### 80.0057 SWIVEL ANGLE FITTING

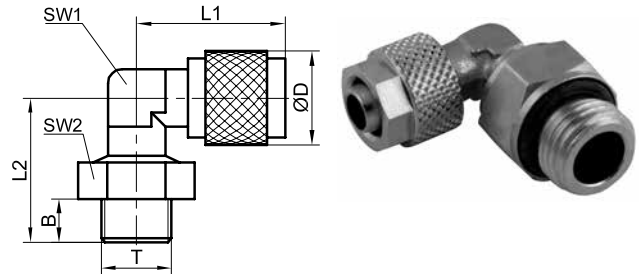

T	HOSE		B	ØD	L1	L2	SW1	Order no.
	ØDz	ØDw						
G1/8	6	4	7	13	21	18	8	80.0058.18.0604
G1/8	8	6	7	13	22	19	9	80.0058.18.0806
G1/4	6	4	11	17	21	21	9	80.0058.14.0604
G1/4	8	6	11	17	24	21	9	80.0058.14.0806
G1/4	10	8	8	17	26	22	11	80.0058.14.1008
G3/8	10	8	11	20	26	25	16	80.0058.38.1008

Material: nickel-plated brass

### 80.0058 ANGLE FITTING

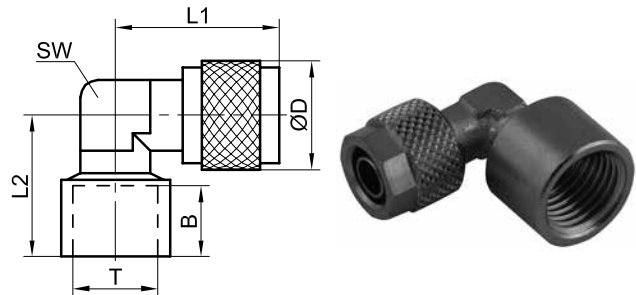

T	HOSE		B	ØD	L1	L2	SW1	SW2	Order no.
	ØDz	ØDw							
G1/8	6	4	6	12	41	20	14	8	80.0063.18.0604
G1/8	8	6	6	14	43	20	14	9	80.0063.18.0806
G1/4	6	4	8	12	41	22	17	8	80.0063.14.0604
G1/4	8	6	8	14	43	22	17	9	80.0063.14.0806
G1/4	10	8	8	16	48	24	17	11	80.0063.14.1008

Material: nickel-plated brass

### 80.0063 T-CONNECTOR

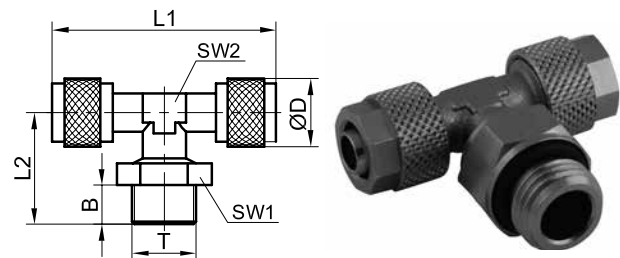

HOSE 1		HOSE 2		ØD	L	SW	Order no.
ØDz	ØDw	ØDz	ØDw				
6	4	6	4	12	33	12	80.0021.6464
8	6	6	4	14	34	12	80.0021.8664
8	6	8	6	14	35	12	80.0021.8686
10	8	6	4	16	36	14	80.0021.10864
10	8	8	6	16	37	14	80.0021.38.10886
10	8	10	8	16	39	14	80.0021.12.108108

Material: nickel-plated brass

### 80.0021 STRAIGHT CONNECTOR

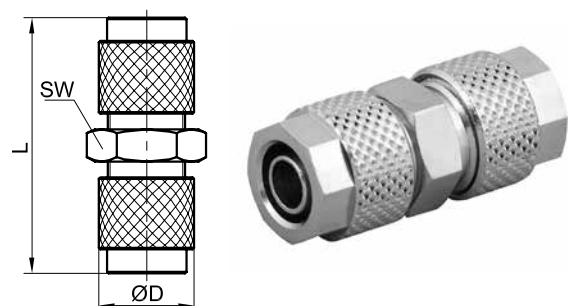

### 80.0022

BULKHEAD CONNECTOR

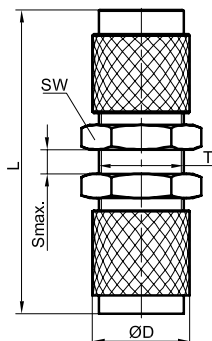

T	HOSE		HOSE		ØD	L	Smax	SW	Order no.
	ØDz	ØDw	ØDz	ØDw					
M10x1	6	4	6	4	12	45	10	14	80.0022.64
M12x1	8	6	6	4	14	48	9	17	80.0022.8664
M12x1	8	6	8	6	14	48	9	17	80.0022.86
M14x1	10	8	6	4	16	50	9	17	80.0022.10864
M14x1	10	8	8	6	16	50	6	17	80.0022.10886
M14x1	10	8	10	8	16	54	5	17	80.0022.108
M16x1	12	10	12	10	19	57	4	19	80.0022.1210

Material: nickel-plated brass

### 80.0062

ANGLE FITTING

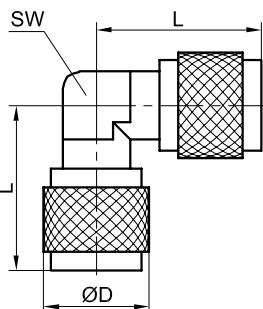

HOSE		ØD	L	SW	Order no.
ØDz	ØDw				
6	4	12	21	8	80.0062.0604L
8	6	14	22	9	80.0062.8664L
8	6	14	22	9	80.0062.0806L
10	8	16	26	11	80.0062.1008L

Material: nickel-plated brass

### 80.0064

T-CONNECTOR

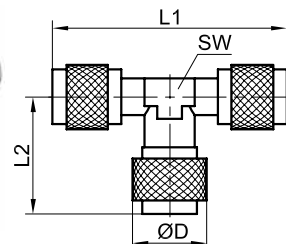

HOSE 1		HOSE 2		ØD	L1	L2	SW	Order no.
ØDz	ØDw	ØDz	ØDw					
6	4	6	4	12	41	21	8	80.0064.0604T
8	6	6	4	14/12	44	21	9	80.0064.8664T
8	6	8	6	14	44	22	9	80.0064.0806T
10	8	6	4	16/14	51	21	11	80.0064.10864T
10	8	8	6	16/14	51	22	11	80.0064.10886T
10	8	10	8	16	51	26	11	80.0064.1008T

Material: nickel-plated brass

### 80.0065

FOUR WAY CONNECTOR

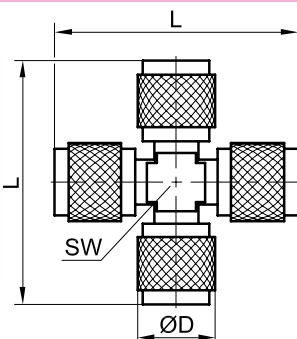

HOSE		ØD	L	SW	Order no.
ØDz	ØDw				
6	4	12	42	8	80.0065.0604
8	6	14	45	9	80.0065.0806
10	8	16	51	11	80.0065.1008

Material: nickel-plated brass

T	HOSE		B	ØD	L1	L2	L3	SW1	SW2	Order no.
	ØDz	ØDw								
M5	4	2	7	8	22	6	17	10	12	60.0002.05.0401
M5	6	4	4	9	23	6	17	8	-	60.0002.05.0601
G1/8	6	4	6	12	28	7,5	23	14	-	60.0002.18.0601
G1/8	8	6	7	9	28	7	25	14	-	60.0002.18.0801
G1/4	6	4	7	12	32	8,5	25	17	-	60.0002.14.0601
G1/4	8	6	7	14	32	8,5	28	17	-	60.0002.14.0801
G1/4	10	8	11	16	32	7	30	17	-	60.0002.14.1001
* G1/4	12	8	8	19	35	11	28	19	19	60.0002.14.1202
G3/8	6	4	9	12	36	10	27	19	-	60.0002.38.0601
G3/8	8	6	10	14	36	7	28	19	-	60.0002.38.0801
G3/8	10	8	10	16	36	7	30	19	-	60.0002.38.1001
* G3/8	12	8	10	19	44	14	31	22	25	60.0002.38.1202
* G3/8	16	12	10	25	44	14	36	22	25	60.0002.38.1602
G1/2	10	8	10	16	42	12	34	24	-	60.0002.12.1001
* G1/2	12	8	12	19	48	15	32	27	27	60.0002.12.1202
* G1/2	16	12	12	25	48	15	37	27	27	60.0002.12.1602
* G1/2	20	18	12	28	48	15	37	27	27	60.0002.12.2002
* G3/4	10	8	15	19	58	18	35	32	32	60.0002.34.1001
* G3/4	12	8	15	19	58	18	35	32	32	60.0002.34.1202
* G3/4	16	12	15	25	58	18	40	32	32	60.0002.34.1602
* G3/4	20	16	15	28	58	18	40	32	32	60.0002.34.2002

Material: aluminium

\* version / material - Fe / Al

### 60.0002 ANGLE FITTING

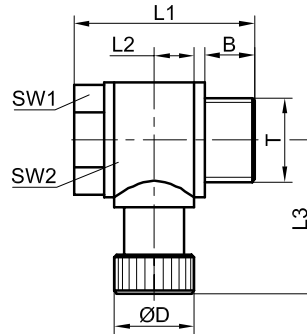

T	HOSE		B	ØD	L	L1	L2	SW1	SW2	Order no.
	ØDz	ØDw								
M5	6	4	5	12	21	7	41	10	12	60.0004.05.0601
G1/4	6	4	8	12	35	11	48	19	19	60.0004.14.0601
G1/4	8	6	8	15	35	11	48	19	19	60.0004.14.0801
G1/4	10	8	8	19	35	11	57	19	19	60.0004.14.1001
G1/4	12	8	8	19	35	11	57	19	19	60.0004.14.1202
G3/8	6	4	10	12	44	14	54	22	25	60.0004.38.0601
G3/8	8	6	10	15	44	14	54	22	25	60.0004.38.0801
G3/8	10	8	10	19	44	14	63	22	25	60.0004.38.1001
G3/8	12	8	10	19	44	14	63	22	25	60.0004.38.1202
G3/8	16	12	10	25	44	14	73	22	25	60.0004.38.1602
G1/2	10	8	12	19	48	15	65	27	27	60.0004.12.1001
G1/2	12	8	12	19	48	15	65	27	27	60.0004.12.1202
G1/2	16	12	12	25	48	15	75	27	27	60.0004.12.1602
G1/2	20	16	12	28	48	15	75	27	27	60.0004.12.2002
G3/4	10	8	15	19	58	18	70	32	32	60.0004.34.1001
G3/4	12	8	15	19	58	18	70	32	32	60.0004.34.1202
G3/4	16	12	15	25	58	18	80	32	32	60.0004.34.1602
G3/4	20	16	15	28	58	18	80	32	32	60.0004.34.2002

Material: aluminium

### 60.0004 DOUBLE-SIDED ANGLE FITTING

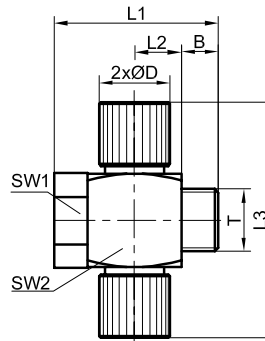

T	B	L1	L2	L3	L4	SW1	SW1	Order no.
G1/4	11	35	8	11	24	19	19	60.0008.14
G3/8	15	44	10	14	30	22	22	60.0008.38
G1/2	15	48	12	15	35	27	27	60.0008.12
G3/4	18	58	15	18	40	32	32	60.0008.34

Material: aluminium

### 60.0008 THREADED ANGLE FITTING

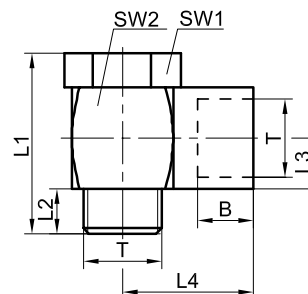



### 60.0013

DOUBLE-SIDED ANGLE FITTING  
WITH SOCKET

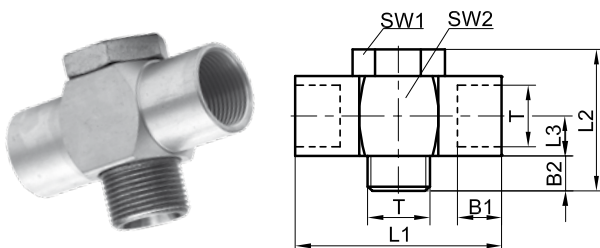

T	B1	B2	L1	L2	L3	SW1	SW2	Order no.
G1/4	11	8	48	35	11	19	19	60.0013.14
G3/8	15	10	60	44	14	22	22	60.0013.38
G1/2	15	12	70	48	15	27	27	60.0013.12
G3/4	18	15	80	58	18	32	32	60.0013.34

Material: aluminium

### 60.0003

T-CONNECTOR BODY

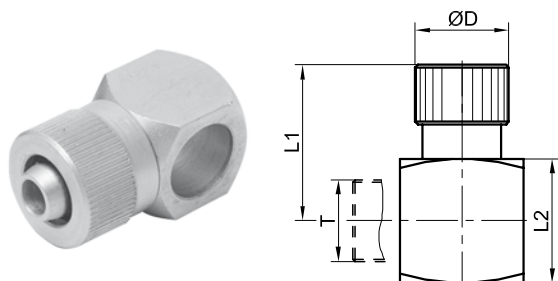

T	HOSE		ØD	L1	L2	Order no.
	ØDz	ØDw				
G1/4	6	4	12	24	19	60.0003.14.0601
G1/4	8	6	15	24	19	60.0003.14.0801
G1/4	10	8	19	28	19	60.0003.14.1001
G1/4	12	8	19	28	19	60.0003.14.1202
G3/8	6	4	12	27	25	60.0003.38.0601
G3/8	8	6	15	27	25	60.0003.38.0801
G3/8	10	8	19	31	25	60.0003.38.1001
G3/8	12	8	19	31	25	60.0003.38.1202
G3/8	16	12	25	36	25	60.0003.38.1602
G1/2	10	8	19	32	27	60.0003.12.1001
G1/2	12	8	19	32	27	60.0003.12.1202
G1/2	16	12	25	37	27	60.0003.12.1602
G1/2	20	18	28	37	27	60.0003.12.2002
G3/4	10	8	19	35	32	60.0003.34.1001
G3/4	12	8	19	35	32	60.0003.34.1202
G3/4	16	12	25	40	32	60.0003.34.1602
G3/4	20	16	28	40	32	60.0003.34.2002

Material: aluminium

### 60.0005

ANGLE FITTING BODY

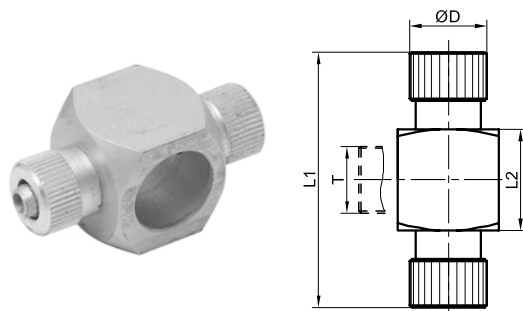

T	HOSE		ØD	L1	L2	Order no.
	ØDz	ØDw				
M5	6	4	12	41	12	60.0005.05.0601
G1/4	6	4	12	48	19	60.0005.14.0601
G1/4	8	6	15	48	18	60.0005.14.0801
G1/4	8	5	15	57	19	60.0005.14.0815
G1/4	10	8	19	57	19	60.0005.14.1001
G1/4	12	8	19	54	19	60.0005.14.1202
G3/8	6	4	12	54	25	60.0005.38.0601
G3/8	8	6	15	63	25	60.0005.38.0801
G3/8	10	8	19	63	25	60.0005.38.1001
G3/8	12	8	19	73	25	60.0005.38.1202
G1/2	10	8	19	65	27	60.0005.12.1001
G1/2	16	12	25	75	27	60.0005.12.1602
G3/4	10	8	19	70	32	60.0005.34.1001
G3/4	12	8	19	70	32	60.0005.34.1202
G3/4	16	12	25	80	32	60.0005.34.1602
G3/4	20	16	28	80	32	60.0005.34.2002

Material: aluminium

### 60.0009

ANGLE FITTING BODY

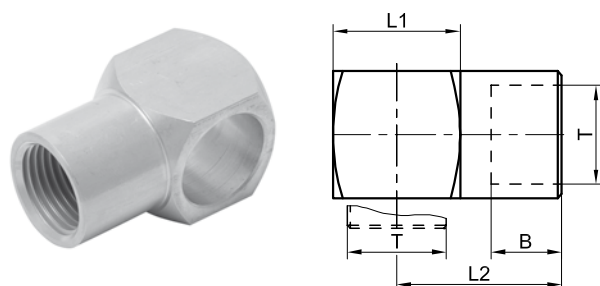

T	B	D	L	Order no.
G1/4	11	19	24	60.0009.14
G3/8	15	22	30	60.0009.38
G1/2	15	27	35	60.0009.12
G3/4	18	32	40	60.0009.34

Material: aluminium

T	B	L	SW	Order no.
G1/4	11	48	19	60.0014.14
G3/8	15	60	22	60.0014.38
G1/2	15	70	27	60.0014.12
G3/4	18	80	32	60.0014.34

Material: aluminium

### 60.0014

DOUBLE-SIDED ANGLE FITTING  
WITH SOCKET, BODY

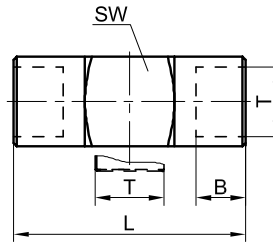

T	B	L1	L2	L3	SW	Order no.
G1/8	11	28	9	4	14	60.0012.18
G1/4	8	35	13	11	19	60.0012.14
G3/8	10	44	19	14	22	60.0012.38
G1/2	12	48	19	15	27	60.0012.12
G3/4	15	58	21	17	32	60.0012.34

Material: nickel-plated carbon steel

### 60.0012

SINGLE SCREW FOR ANGLE FITTINGS  
(FOR PRODUCTS 60.0003, 60.0005, 60.0009, 60.0014)

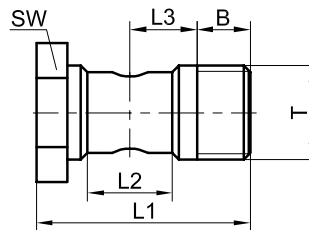

T	HOSE		ØD	L1	Order no.
	ØDz	ØDw			
M10x1	6	4	12	13	60.0011.0601
M12x1.25	8	6	15	13	60.0011.0801
M16x1.5	10	8	19	16	60.0011.1001
M16x1.5	12	8	19	16	60.0011.1202
M22x1.5	16	12	25	20	60.0011.1602
M24x1.5	20	16	28	20	60.0011.2002

Material: aluminium

### 60.0011

CONNECTION NUT (FOR PRODUCTS 60.0001,  
60.0002, 60.0003, 60.0004, 60.0005)

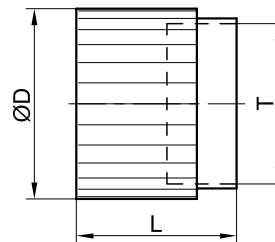

T	HOSE		B	L1	L2	SW1	SW2	Order no.
	ØDz	ØDw						
G1/8	10	4	9	33	19	17	17	80.0061.14.1004
G1/4	12	6	9	35	20	17	19	80.0061.14.1206
G1/4	14	8	9	38	23	22	22	80.0061.14.1408
G1/4	15	9	9	39	24	22	24	80.0061.14.1509
G1/4	16	10	9	39	24	22	24	80.0061.14.1610
G3/8	10	4	9	33	19	19	17	80.0061.38.1004
G3/8	12	6	9	35	20	19	19	80.0061.38.1206
G3/8	14	8	9	38	23	22	22	80.0061.38.1408
G3/8	15	9	9	39	24	22	24	80.0061.38.1509
G3/8	16	10	9	39	24	22	24	80.0061.38.1610
G3/8	20	13	9	41	25	27	30	80.0061.38.2013
G1/2	10	4	11	36	19	24	17	80.0061.12.1004
G1/2	12	6	11	38	20	24	19	80.0061.12.1206
G1/2	14	8	11	40	23	24	22	80.0061.12.1408
G1/2	15	9	11	40	24	24	24	80.0061.12.1509
G1/2	16	10	11	40	24	24	24	80.0061.12.1610
G1/2	20	13	11	43	25	27	30	80.0061.12.2013

Material: aluminium

### 80.0061

STRAIGHT FITTING FOR REINFORCED  
PVC HOSES

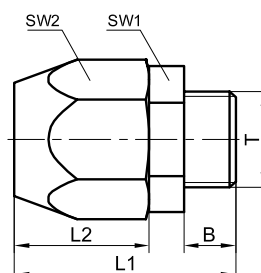

### 80.0235.01

STRAIGHT FITTING  
FOR PLASTIC HOSES

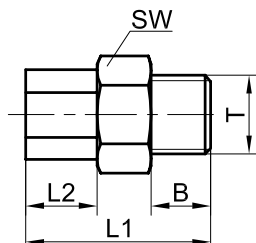

T	HOSE		B	L1	L2	SW	Order no.
	ØDz	ØDw					
G1/8	6	4	6	28	12	13	80.0235.01.1864
G1/8	8	6	6	29	12	13	80.0235.01.1886
G1/4	6	4	8	30	12	17	80.0235.01.1464
G1/4	8	6	8	32	12	17	80.0235.01.1486
G1/4	10	8	10	31	12	18	80.0235.01.14108
G3/8	8	6	10	34	12	19	80.0235.01.3886
G3/8	12	9	10	38	12	19	80.0235.01.38129

Construction materials: POM

### 80.0235.02

ANGLE FITTING  
FOR PLASTIC HOSES

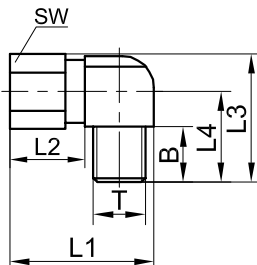

T	HOSE		B	L1	L2	L3	L4	SW	Order no.
	ØDz	ØDw							
G1/8	6	4	11	23	17	29	17	12	80.0235.02.1864
G1/8	8	6	11	25	17	29	18	14	80.0235.02.1886
G1/4	6	4	13	25	17	33	19	12	80.0235.02.1464
G1/4	8	6	13	27	17	33	20	14	80.0235.02.1486
G1/4	12	9	14	32	19	37	23	19	80.0235.02.14129
G3/8	12	9	14	32	19	37	26	19	80.0235.02.38129

Construction materials: POM

### 80.0235.03

ANGLE FITTING  
FOR PLASTIC HOSES

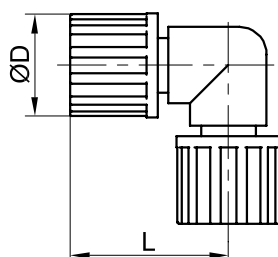

ØDz	HOSE		ØD	L	Order no.
	ØDw				
6	4		14	23	80.0235.03.64
8	6		19	29	80.0235.03.86
10	8		21	36	80.0235.03.108
12	9		21	41	80.0235.03.129

Construction materials: POM

HOSE		F	ØD	L1	L2	L3	SW	H	Order no.
ØDz	ØDw								
6	4	12	4.3	52	25	12	12	15	<b>80.0235.04.64</b>
8	6	12	4.3	52	25	14	14	18	<b>80.0235.04.86</b>
10	8	13	4.3	54	38	19	17	20	<b>80.0235.04.108</b>
12	9	15	4.3	64	32	17	19	22	<b>80.0235.04.129</b>

Construction materials: POM - polyacetal

## 80.0235.04

T-CONNECTOR  
FOR PLASTIC HOSES

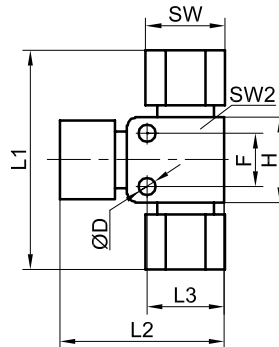

T	HOSE		L1	L2	Smax	SW1	SW2	Order no.
	ØDz	ØDw						
M10	6	4	50	13	6	14	12	<b>80.0235.05.64</b>
M12	8	6	52	13	8	17	14	<b>80.0235.05.86</b>
M16	12	9	60	14	8	19	19	<b>80.0235.05.129</b>

Construction materials: POM

## 80.0235.05

BULKHEAD FITTING  
FOR PLASTIC HOSES

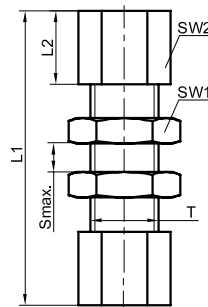

### TECHNICAL SPECIFICATIONS

<b>Maximum operating pressure:</b>	20 bar
<b>Medium:</b>	compressed air or other non-aggressive gas, water, non-aggressive liquids
<b>Operating temperature range:</b>	0 to +80°C
<b>Materials:</b>	
<b>Body</b>	- brass
<b>Clamping ring</b>	- brass
<b>Nut</b>	- brass

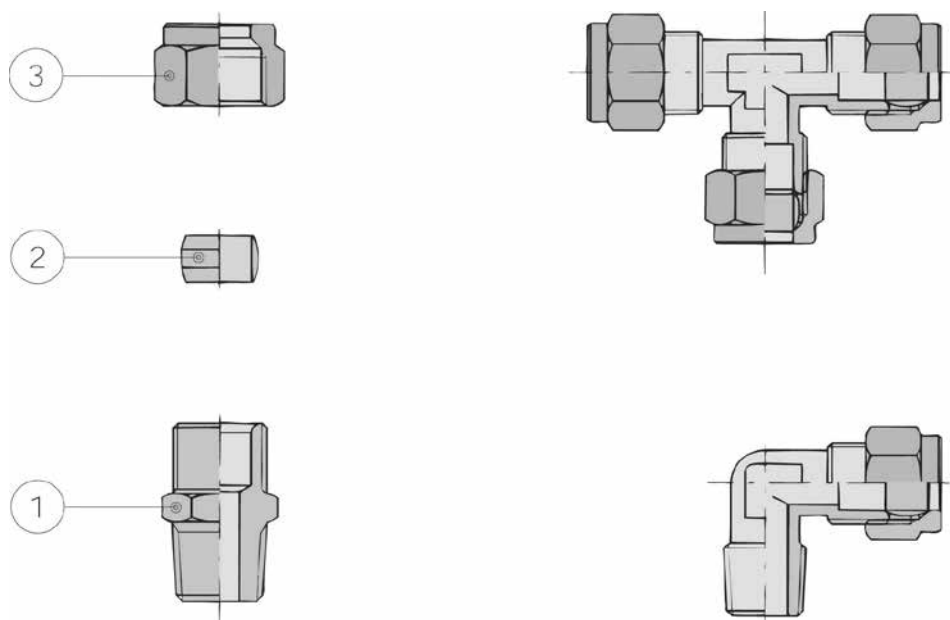

1) Body, 2) Clamping ring (barrel), 3) Nut

Multi-purpose, reliable design connectors are used to assemble pneumatic installations using copper, steel, aluminium and plastic pipes. The sealing of the pipe in the connection is carried out by means of a clamping ring (barrel).

T	HOSE ØDz	B	L	SW1	SW2	Order no.
G1/8	4	6	26	10	13	80.1020.18.04
G1/8	6	6	28	12	13	80.1020.18.06
G1/8	8	6	29	14	13	80.1020.18.08
G1/4	4	10	28	10	14	80.1020.14.04
G1/4	6	6	31	12	17	80.1020.14.06
G1/4	8	6	32	14	17	80.1020.14.08
G1/4	10	6	35	19	17	80.1020.14.10
G1/4	12	10	35	21	18	80.1020.14.12
G3/8	6	10	29	12	17	80.1020.38.06
G3/8	8	9	36	14	22	80.1020.38.08
G3/8	10	9	39	19	22	80.1020.38.10
G3/8	12	11	35	21	18	80.1020.38.12
G3/8	14	10	39	23	22	80.1020.38.14
G1/2	10	12	37	19	21	80.1020.12.10
G1/2	12	12	37	21	21	80.1020.12.12
G1/2	14	10	41	23	27	80.1020.12.14
G1/2	16	12	42	25	22	80.1020.12.16
G1/2	22	12	43	34	30	80.1020.12.22
G3/4	22	12	48	34	32	80.1020.34.22
G1	22	--	51	34	41	80.1020.10.22

Material: nickel-plated brass

## 80.1020

STRAIGHT FITTING FOR COPPER PIPES

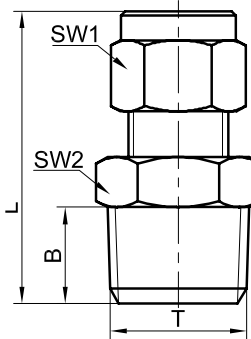

T	HOSE ØDz	B	L	SW1	SW2	Order no.
G1/8	4	9	24	10	14	80.1021.18.04
G1/8	6	9	26	12	14	80.1021.18.06
G1/8	8	9	30	14	14	80.1021.18.08
G1/4	4	10	27	10	17	80.1021.14.04
G1/4	6	10	28	12	17	80.1021.14.06
G1/4	8	11	28	14	17	80.1021.14.08
G1/4	10	11	32	19	17	80.1021.14.10
G1/4	12	11	33	21	17	80.1021.14.12
G3/8	8	12	29	14	20	80.1021.38.08
G3/8	10	12	32	19	20	80.1021.38.10
G3/8	12	12	32	21	20	80.1021.38.12
G3/8	14	12	36	23	20	80.1021.38.14
G1/2	10	12	31	19	24	80.1021.12.10
G1/2	12	12	32	21	24	80.1021.12.12
G1/2	14	12	34	23	24	80.1021.12.14
G1/2	16	12	39	24	25	80.1021.12.16

Material: nickel-plated brass

## 80.1021

STRAIGHT FITTING FOR COPPER PIPES

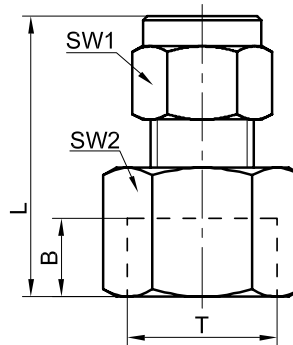

T	HOSE ØDz	B	L	SW	Order no.
G1/8	6x0.5	8	47	14	60.0093.18.0605
G1/4	10x1	10	50	19	60.0093.14.1001
G3/8	12x1	12	59	24	60.0093.38.1201
G1/2	16x1	14	52	27	60.0093.12.1601
G3/4	20x1	16	72	32	60.0093.34.2001

Material: zinc-plated steel

## 60.0093

STRAIGHT FITTING  
FOR EXPANDED TUBES

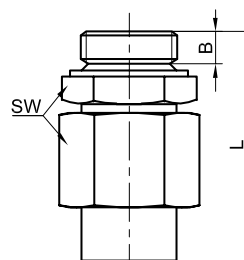

# FITTINGS, ACCESSORIES AND HOSES

push-in connectors for pipes



## 80.1028

ANGLE CONNECTOR FOR COPPER PIPES

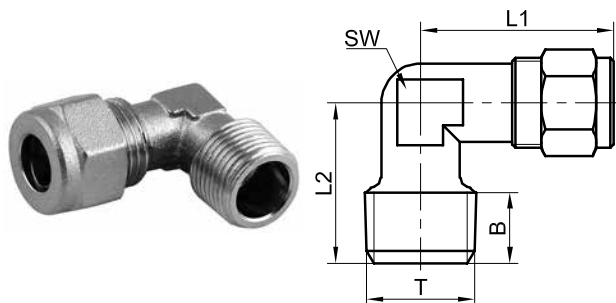

T	HOSE	B	L1	L2	SW	Order no.
	ØDz					
R1/8	4	8	22	15	8	80.1028.18.04
R1/8	6	8	26	19	9	80.1028.18.06
R1/8	8	8	27	19	11	80.1028.18.08
R1/4	6	11	24	19	9	80.1028.14.06
R1/4	8	11	28	21	11	80.1028.14.08
R1/4	10	11	33	24	13	80.1028.14.10
R1/4	12	12	35	24	14	80.1028.14.12
R3/8	8	10	32	25	13	80.1028.38.08
R3/8	10	12	33	24	13	80.1028.38.10
R3/8	12	12	33	25	14	80.1028.38.12
R3/8	14	12	38	26	17	80.1028.38.14
R1/2	10	11	33	25	14	80.1028.12.10
R1/2	12	11	34	25	14	80.1028.12.12
R1/2	14	14	38	29	17	80.1028.12.14
R1/2	16	14	40	28	17	80.1028.12.16
R3/4	22	15	43	34	27	80.1028.34.22

Material: nickel-plated brass

## 80.1032

ANGLE CONNECTOR FOR COPPER PIPES

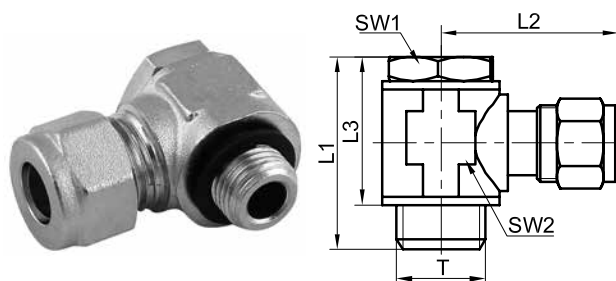

T	HOSE	B	L1	L2	L3	SW1	SW2	Order no.
	ØDz							
G1/8	6	8	31	24	13	14	12	80.1032.18.06
G1/8	8	8	31	28	18	14	14	80.1032.18.08
G1/4	6	10	34	27	18	17	12	80.1032.14.06
G1/4	8	10	34	28	18	17	17	80.1032.14.08
G1/4	10	5	34	33	21	17	19	80.1032.14.10
G1/4	14	8	44	36	25	17	23	80.1032.14.14
G3/8	8	6	35	29	21	19	14	80.1032.38.08
G3/8	10	6	35	33	21	19	19	80.1032.38.10
G3/8	14	9	46	36	25	22	23	80.1032.38.14
G1/2	14	11	49	36	25	24	24	80.1032.12.14
G3/4	22	12	64	46	32	32	32	80.1032.34.22

Material: nickel-plated brass

## 80.1029

ANGLE CONNECTOR FOR COPPER PIPES

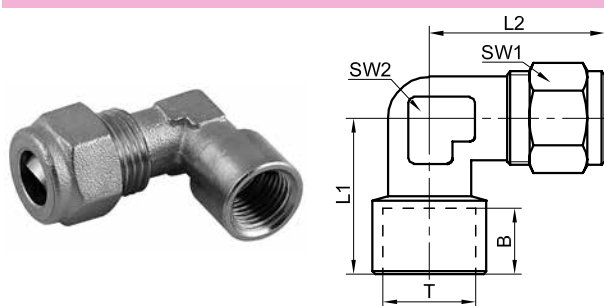

T	HOSE	B	L1	L2	SW1	SW2	Order no.
	ØDz						
G1/8	4	8	23	18	12	11	80.1029.18.04
G1/8	6	8	24	19	12	11	80.1029.18.06
G1/8	8	8	27	20	14	11	80.1029.18.08
G1/4	6	10	26	23	12	11	80.1029.14.06
G1/4	8	10	28	24	14	13	80.1029.14.08
G1/4	10	11	34	25	19	13	80.1029.14.10
G1/4	12	11	34	25	21	14	80.1029.14.12
G3/8	8	11	30	25	14	14	80.1029.38.08
G3/8	10	11	33	25	19	14	80.1029.38.10
G3/8	12	11	33	26	21	14	80.1029.38.12
G1/2	10	11	33	26	19	14	80.1029.12.10
G1/2	12	11	33	26	21	15	80.1029.12.12
G1/2	14	11	39	30	23	18	80.1029.12.14

Material: nickel-plated brass

## 80.1025

T-CONNECTOR FOR COPPER PIPES

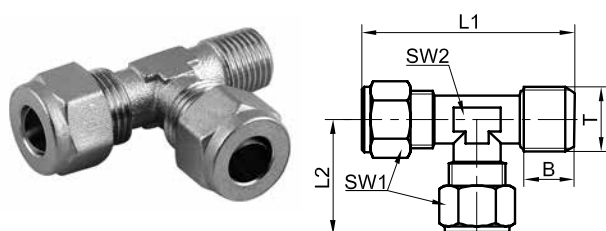

T	HOSE	B	L1	L2	SW1	SW2	Order no.
	ØDz						
R1/8	4	8	35	21	8	10	80.1025.18.04
R1/8	6	8	43	24	9	12	80.1025.18.06
R1/8	8	8	45	26	12	14	80.1025.18.08
R1/4	6	10	45	25	9	12	80.1025.14.06
R1/4	8	10	46	26	12	14	80.1025.14.08
R1/4	10	11	55	31	13	19	80.1025.14.10
R3/8	8	11	49	26	13	14	80.1025.38.08
R3/8	10	11	56	31	13	19	80.1025.38.10
R3/8	12	11	58	33	14	21	80.1025.38.12

Material: nickel-plated brass

T	HOSE ØDz	B	L1	L2	SW1	SW2	Order no.
R1/8	4	8	42	15	10	8	80.1026.18.04
R1/8	6	8	49	19	12	9	80.1026.18.06
R1/8	8	8	53	18	14	12	80.1026.18.08
R1/4	6	11	49	20	12	9	80.1026.14.06
R1/4	8	11	53	21	14	12	80.1026.14.08
R1/4	10	11	63	23	19	13	80.1026.14.10
R1/4	12	12	66	24	22	14	80.1026.14.12
R3/8	8	12	57	23	14	13	80.1026.38.08
R3/8	10	12	62	24	19	13	80.1026.38.10
R3/8	12	13	66	25	22	14	80.1026.38.12
R3/8	14	13	75	26	27	16	80.1026.38.14
R1/2	4	12	77	31	23	23	80.1026.12.04
R1/2	12	14	67	26	22	14	80.1026.12.12
R1/2	16	14	79	29	30	17	80.1026.12.16
R1/2	18	15	92	32	32	20	80.1026.12.18

Material: nickel-plated brass

## 80.1026

T-CONNECTOR FOR COPPER PIPES

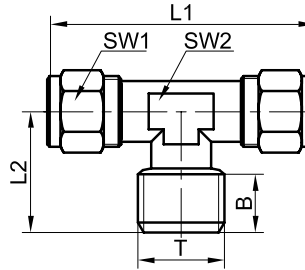

T	HOSE ØDz	B	L1	L2	SW	Order no.
G1/8	4	6	28	16	13	80.1031.18.06
G1/8	6	6	32	19	13	80.1031.18.08
G1/4	6	8	31	16	17	80.1031.14.06
G1/4	8	8	34	19	17	80.1031.14.08
G1/4	10	8	35	20	17	80.1031.14.10
G3/8	8	11	38	19	22	80.1031.38.08
G3/8	10	11	39	20	22	80.1031.38.10
G3/8	14	11	40	21	22	80.1031.38.14
G1/2	14	12	42	21	27	80.1031.12.14

Material: nickel-plated brass

## 80.1031

COPPER PIPES FITTINGS  
ADAPTER

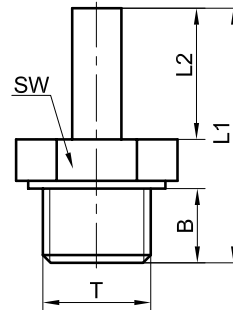

HOSE ØDz	L	SW1	SW2	Order no.
6	34	12	12	80.1027.06
8	35	13	14	80.1027.08
10	43	16	19	80.1027.10
12	43	18	22	80.1027.12
14	46	21	27	80.1027.14
16	52	22	30	80.1027.16
22	55	30	34	80.1027.22

Material: nickel-plated brass

## 80.1027

STRAIGHT CONNECTOR FOR COPPER PIPES

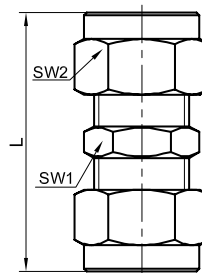

T	HOSE ØDz	L	Smax	SW1	SW2	SW3	Order no.
M10	4	48	15	10	13	12	80.1023.04
M12	6	48	15	14	14	14	80.1023.06
M16	8	53	15	14	17	19	80.1023.08
M18	10	59	16	19	21	22	80.1023.10
M18	12	68	20	22	24	22	80.1023.12
M20	14	72	20	24	24	24	80.1023.14

Material: nickel-plated brass

## 80.1023

BULKHEAD CONNECTOR  
FOR COPPER PIPES

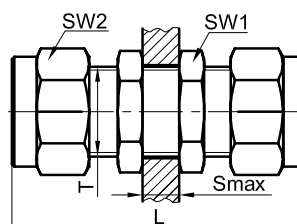



# FITTINGS, ACCESSORIES AND HOSES

push-in connectors for pipes



## 80.1022

ANGLE CONNECTOR FOR COPPER PIPES

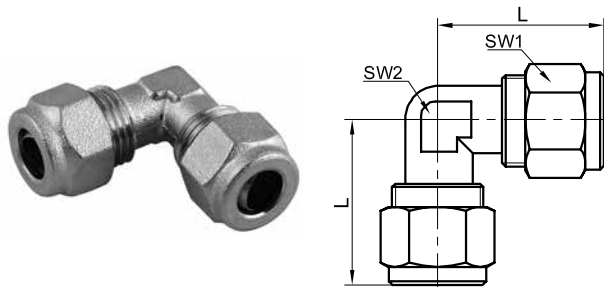

HOSE ØDz	L	SW1	SW2	Order no.
4	21	10	8	80.1022.04
6	25	12	9	80.1022.06
8	28	14	11	80.1022.08
10	32	19	13	80.1022.10
12	33	21	14	80.1022.12
14	39	23	17	80.1022.14
16	41	25	17	80.1022.16
22	43	34	27	80.1022.22

Material: nickel-plated brass

## 80.1024

T-CONNECTOR FOR COPPER PIPES

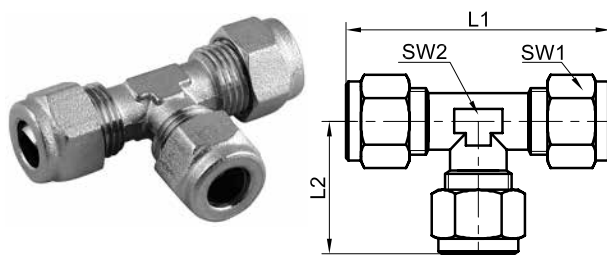

HOSE ØDz	L1	L2	SW1	SW2	Order no.
4	42	21	10	8	80.1024.04
6	50	25	12	9	80.1024.06
8	53	27	14	12	80.1024.08
10	62	31	19	13	80.1024.10
12	67	34	21	14	80.1024.12
14	72	36	23	18	80.1024.14
16	80	40	25	17	80.1024.16
22	86	43	34	27	80.1024.22

Material: nickel-plated brass

## 80.1030

FOUR WAY CONNECTOR FOR COPPER PIPES

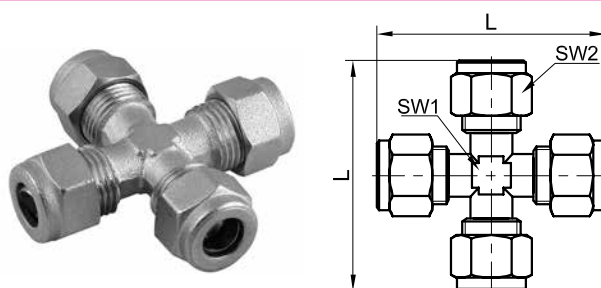

HOSE ØDz	L	SW1	SW2	Order no.
6	48	8	12	80.1030.06
8	62	11	14	80.1030.08
10	64	13	19	80.1030.10
12	70	17	21	80.1030.12
14	75	17	23	80.1030.14

Material: nickel-plated brass

## 80.0133

CLAMPING RING  
FOR COPPER PIPE FITTINGS

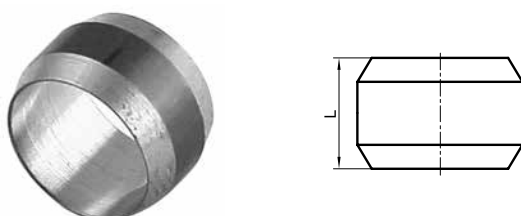

HOSE ØDz	L	Order no.
4	5.5	80.0133.04
6	6.5	80.0133.06
8	6.5	80.0133.08
10	7.5	80.0133.10
12	8	80.0133.12
14	8.5	80.0133.14
15	9	80.0133.15
16	9.5	80.0133.16
22	10	80.0133.22

Material: nickel-plated brass

T	B	d	L	SW	Order no.
G1/8	6	3.2	22	14	60.0101.18
G1/4	8	5.5	27	17	60.0101.14
G3/8	8	8	28	22	60.0101.38
G1/2	10	12	33	27	60.0101.12
G3/4	13	16	40	32	60.0101.34

Material: zinc-plated steel

### 60.0101

STRAIGHT CONNECTOR

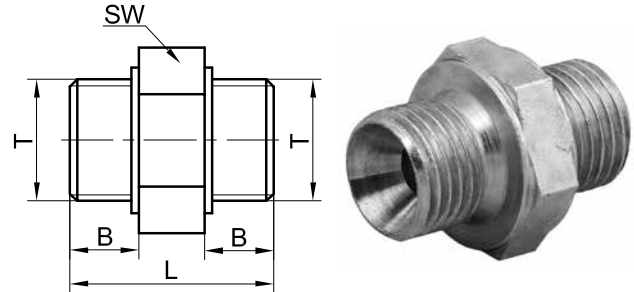

T	B	L	SW	Order no.
M5	4	12	8	80.0120.M5
G1/8	6	17	14	80.0120.18
G1/4	8	21	17	80.0120.14
G3/8	9	23	19	80.0120.38
G1/2	10	26	24	80.0120.12
G3/4	12	30	30	80.0120.34
G1	19	37	34	80.0120.10

Material: nickel-plated brass

### 80.0120

STRAIGHT CONNECTOR

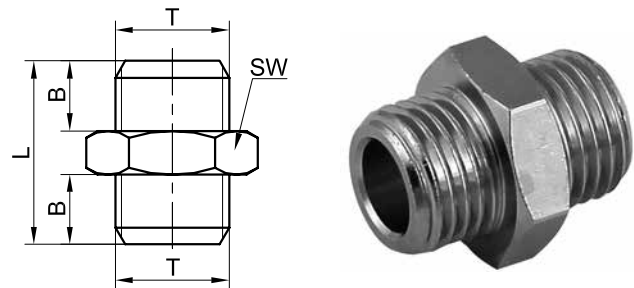

T	B	L1	L2	SW1	SW2	Order no.
R1/8	7	27	9	15	5	80.0400.18
R1/4	11	34	10	19	6	80.0400.14
R3/8	11	37	10	22	8	80.0400.38
R1/2	14	45	12	27	12	80.0400.12
R3/4	16	53	17	36	14	80.0400.34
R1	19	64	20	46	19	80.0400.10

Material: brass

### 80.0400

STRAIGHT FITTING, NIPPLE TYPE (UNION)

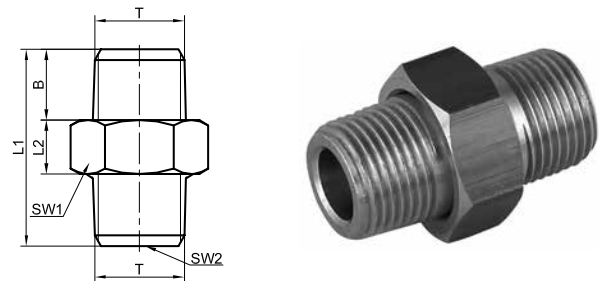

T1	T2	B1	B2	L	SW	Order no.
G1/8	M5	5	6	21	14	60.0102.1805
G1/4	G1/8	6	8	26	17	60.0102.1418
G3/8	G1/4	8	8	30	22	60.0102.3814
G1/2	G3/8	8	10	38	27	60.0102.1238
G3/4	G1/2	10	13	40	32	60.0102.3412

Material: zinc-plated steel

### 60.0102

REDUCER CONNECTOR

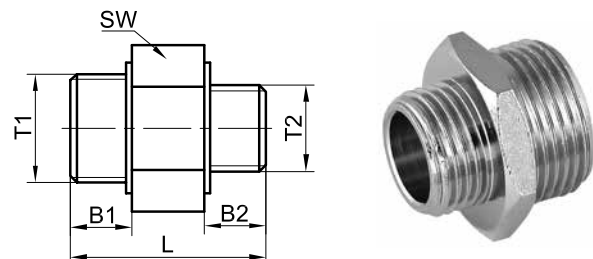

### 60.0103

REDUCER CONNECTOR

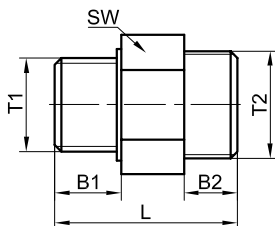

T1	T2	B1	B2	L	SW	Order no.
G1/4	M16x1.5	10	10.5	32	19	60.0103.1416
G3/8	M20x1.5	12	12	37	24	60.0103.3820
G1/2	M24x1.5	14	12	41	27	60.0103.1224
G3/4	M30x2	16	14	47	32	60.0103.3430

Material: zinc-plated steel

### 60.0111

REDUCER CONNECTOR

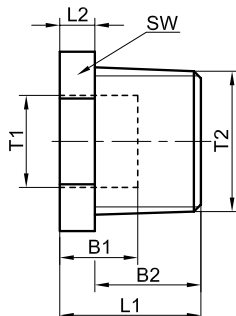

T1	T2	B1	B2	L1	L2	SW	Order no.
M5	R1/8	7	8	13	5	10	60.0111.1805
G1/8	R1/4	9	11	16	5	14	60.0111.1418
G1/8	R3/8	9	12	17	5	19	60.0111.3814
G1/4	R3/8	11	12	17	5	19	60.0111.3814
G1/8	R1/2	9	15	20	5	22	60.0111.1218
G1/4	R1/2	11	15	20	5	22	60.0111.1214
G3/8	R1/2	15	15	20	5	22	60.0111.1238
G1/8	R3/4	9	18	23	5	27	60.0111.3418
G1/4	R3/4	11	18	23	5	27	60.0111.3414
G3/8	R3/4	15	18	23	5	27	60.0111.3438
G1/2	R3/4	16	16	23	7	27	60.0111.3412
G3/8	R1	15	20	27	7	41	60.0111.0138
G1/2	R1	17	20	27	7	41	60.0111.0112
G3/4	R1	16	20	27	7	41	60.0111.0134

Material: zinc-plated steel

### 60.0112

REDUCER CONNECTOR

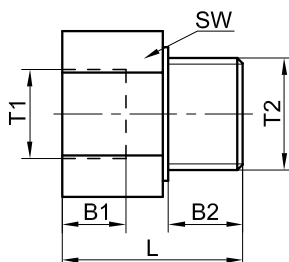

T1	T2	B1	B2	L	SW	Order no.
G1/8	G1/4	8	10	26	19	60.0112.1418
G1/4	G3/8	10	12	30	24	60.0112.3814
G3/8	G1/2	12	14	34	27	60.0112.1238
G1/2	G3/4	14	16	36	32	60.0112.3412
G1	G3/4	18	16	50	36	60.0112.34100

Material: zinc-plated steel

### 60.0113

REDUCER CONNECTOR

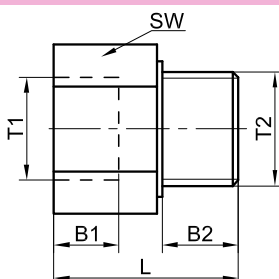

T1	T2	B1	B2	L	SW	Order no.
G1/8	M12x1.25	8	12	27	17	60.0113.1218
G1/4	M12x1.25	10	12	32	19	60.0113.1214
G1/4	M14x1.5	10	12	33	19	60.0113.1414
G3/8	M16x1.5	12	12	35	24	60.0113.1638
G1/2	M22x1.5	14	14	42	27	60.0113.2212
G3/4	M26x1.5	16	16	45	32	60.0113.2634

Material: zinc-plated steel

T1	T2	L1	L2	Smax	SW1	SW2	Order no.
M16x1.5	G1/8	18	14	10	22	19	80.0401.18
M20x1.5	G1/4	25	21	16	27	24	80.0401.14
M26x1.5	G3/8	26	21	15	32	30	80.0401.38
M28x1.5	G1/2	33	27	21	36	32	80.0401.12

Material: nickel-plated brass

### 80.0401

BULKHEAD CONNECTOR

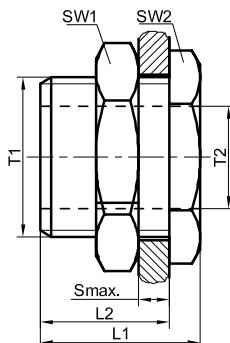

T	L	SW	Order no.
M5	11	8	80.0124.M5
G1/8	15	14	80.0124.18
G1/4	22	17	80.0124.14
G3/8	24	22	80.0124.38
G1/2	30	26	80.0124.12
G3/4	32	32	80.0124.34
G1	46	40	80.0124.100

Material: nickel-plated brass

### 80.0124

MUFF

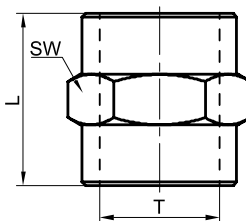

T	L	SW	Order no.
M5	12	9	60.0114.05
G1/8	20	14	60.0114.18
G1/4	24	17	60.0114.14
G3/8	30	22	60.0114.38
G1/2	32	27	60.0114.12
G3/4	36	32	60.0114.34

Material: brass

### 60.0114

MUFF

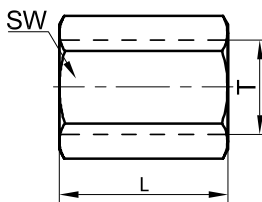

T1	T2	B	L	SW	Order no.
M5	G1/8	5	13	14	80.0121.M518
G1/8	G1/4	8	19	17	80.0121.1814
G1/8	G3/8	8	20	22	80.0121.1838
G1/8	G1/2	10	24	24	80.0121.1812
G1/4	G3/8	10	23	22	80.0121.1438
G1/4	G1/2	10	25	24	80.0121.1412
G3/8	G1/2	11	28	24	80.0121.3812
G1/2	G1	18	39	40	80.0121.1210
G1/2	G3/4	12	40	30	80.0121.1234
G3/4	G1	18	41	40	80.0121.3410

Material: nickel-plated brass

### 80.0121

REDUCTION MUFF

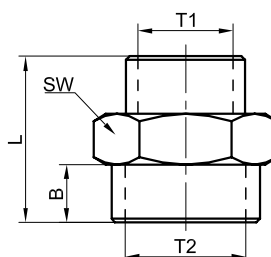

### 80.2030

REDUCER CONNECTOR

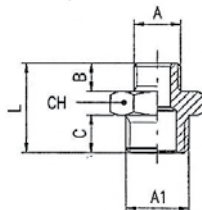

A	A1	B	C	L	CH	Order no.
G M5	G 1/8	4	6	14.5	14	80.2030.0518
G 1/8	G 1/4	6	8	19	17	80.2030.1814
G 1/8	G 3/8	6	9	20	19	80.2030.1838
G 1/4	G 3/8	8	9	22	19	80.2030.1438
G 1/4	G 1/2	8	10	23.5	24	80.2030.1412
G 3/8	G 1/2	9	10	24.5	24	80.2030.3812
G 1/2	G 3/4	10	12	27.5	30	80.2030.1234

Material: nickel-plated brass

### 80.2090

REDUCER CONNECTOR

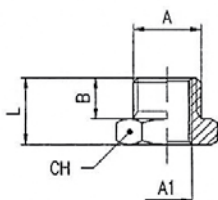

A	A1	B	L	CH	Order no.
G 1/8	G M5	6	10.5	14	80.2090.18M5-A
G 1/4	G 1/8	8	13	17	80.2090.1418-A
G 3/8	G 1/8	9	14	19	80.2090.3818-A
G 3/8	G 1/4	9	14	19	80.2090.3814-A
G 1/2	G 1/8	10	15.5	24	80.2090.1218-A
G 1/2	G 1/4	10	15.5	24	80.2090.1214-A
G 1/2	G 3/8	10	15.5	24	80.2090.1238-A
G 3/4	G 3/8	12	17.5	30	80.2090.3438-A
G 3/4	G 1/2	12	17.5	30	80.2090.3412-A

Material: nickel-plated brass

### 80.0203

ANGLE CONNECTOR

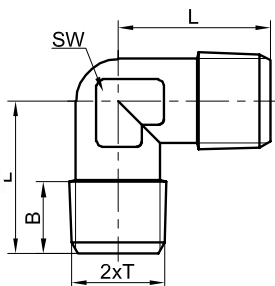

T	B	L	SW	Order no.
R1/8	7	19	12	80.0203.18
R1/4	11	24	13	80.0203.14
R3/8	12	27	16	80.0203.38
R1/2	14	30	20	80.0203.12
R3/4	14	32	27	80.0203.34
R1	17	39	30	80.0203.10

Material: nickel-plated brass

### 80.0200

ELBOW WITH FEMALE AND MALE THREADS

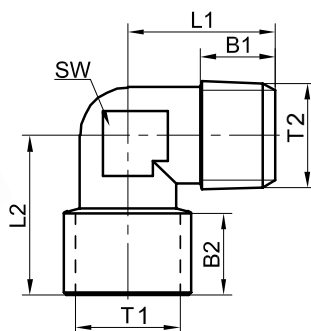

T1	T2	B1	B2	L1	L2	SW	Order no.
G1/8	R1/8	8.5	8	21	18	11	80.0200.01.18
G1/4	R1/4	11	11	25.5	24	13	80.0200.01.14
G3/8	R3/8	12	11	28	27	17	80.0200.01.38
G1/2	R1/2	15	14	32	29.5	20	80.0200.01.12
G3/4	R3/4	16	14	36.5	32	27	80.0200.01.34
G1	R1	19	17	45	39	30	80.0200.01.10

Material: nickel-plated brass

T	B	L	SW	Order no.
G1/8	8	21	12	80.0204.18
G1/4	11	26	13	80.0204.14
G3/8	12	28	16	80.0204.38
G1/2	15	32	20	80.0204.12
G3/4	16	37	27	80.0204.34
G1	19	45	30	80.0204.10

Material: nickel-plated brass

### 80.0204

ELBOW WITH FEMALE THREADS

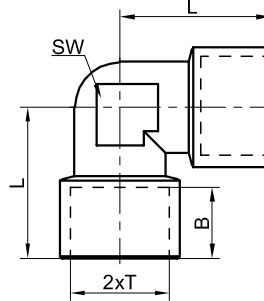

T	B	L1	L2	SW	Order no.
R1/8	8	35	18	12	80.0202.18
R1/4	11	46	23	13	80.0202.14
R3/8	11	52	26	16	80.0202.38
R1/2	14	59	30	20	80.0202.12
R3/4	13	64	32	27	80.0202.34
R1	15	78	39	30	80.0202.10

Material: nickel-plated brass

### 80.0202

T-CONNECTOR WITH MALE THREADS

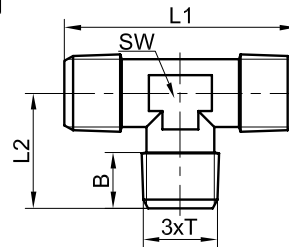

T	B	L1	L2	SW	Order no.
G1/8	8	39	20	12	80.0201.18
G1/4	11	49	25	13	80.0201.14
G3/8	12	54	27	16	80.0201.38
G1/2	15	64	32	20	80.0201.12
G3/4	16	73	37	27	80.0201.34
G1	19	90	45	30	80.0201.10

Material: nickel-plated brass

### 80.0201

T-CONNECTOR WITH FEMALE THREADS

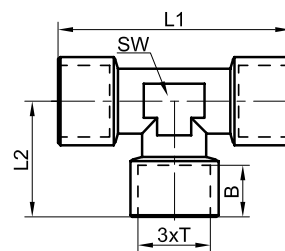

T	T2	B2	B1	L1	L2	SW	Order no.
G1/8	R1/8	8	8	37	17.5	12	80.0304.18
G1/4	R1/4	11	11	48	24.5	13	80.0304.14
G3/8	R3/8	11	12	53	27	16	80.0304.38
G1/2	R1/2	14	15	62	32	20	80.0304.12
G3/4	R3/4	14	16	73	32	27	80.0304.34
G1	R1	16	19	90	39	30	80.0304.100

Material: nickel-plated brass

### 80.0304

T-CONNECTOR WITH FMF THREADS

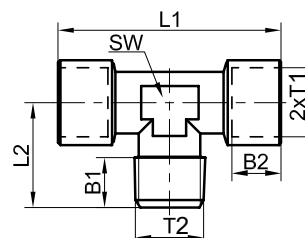

### 80.0305

T-CONNECTOR WITH MFF THREADS

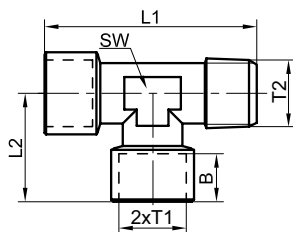

T1	T2	B1	B2	L1	L2	SW	Order no.
G1/8	R1/8	8	8.5	39	20	12	80.0305.18
G1/4	R1/4	11	11	49	25	13	80.0305.14
G3/8	R3/8	11	12	54	27	16	80.0305.38
G1/2	R1/2	14	15	64	32	20	80.0305.12
G3/4	R3/4	14	16	69	37	27	80.0305.34
G1	R1	18	19	84	45	30	80.0305.100

Material: nickel-plated brass

### 80.0205

ANGULAR CONNECTOR WITH FASTENING

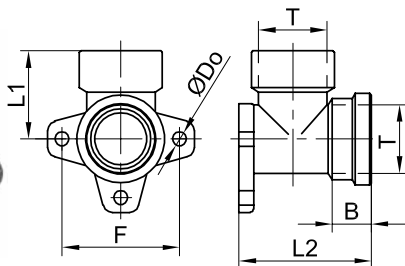

T	B	ØDo	F	L1	L2	Order no.
G1/2	11	4.4	36	40	50	80.0205.12

Material: nickel-plated brass

### 80.0207

T-CONNECTOR BODY WITH MFF THREADS

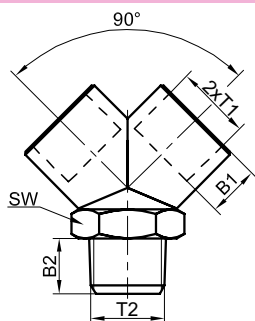

T1	T2	B1	B2	SW	Order no.
G1/8	R1/8	8	9	14	80.0207.18
G1/4	R1/4	11	11	17	80.0207.14
G3/8	R3/8	11	12	22	80.0207.38
G1/2	R1/2	14	16	26	80.0207.12

Material: nickel-plated brass

### 80.0208

T-CONNECTOR BODY WITH FEMALE THREAD

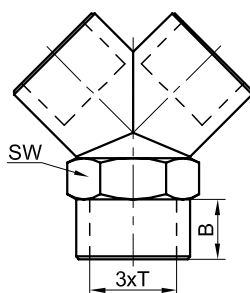

T	B	SW	Order no.
G1/8	8	14	80.0208.18
G1/4	11	17	80.0208.14
G3/8	11	22	80.0208.38
G1/2	14	26	80.0208.12

Material: nickel-plated brass

T	ØDo	F	H	L1	L2	L3	Order no.
G1/8	-	-	10	19	14	-	60.0157.18
G1/4	4.5	19	17	27	23	4	60.0157.14
G3/8	5.5	25	22	36	28	5.5	60.0157.38
G1/2	5.5	30	26	41	34	5.5	60.0157.12
G3/4	5.5	38	32	50	40	6	60.0157.34
G1	6.5	44	38	60	48	8	60.0157.10

Material: aluminium

### 60.0157 T-CONNECTOR

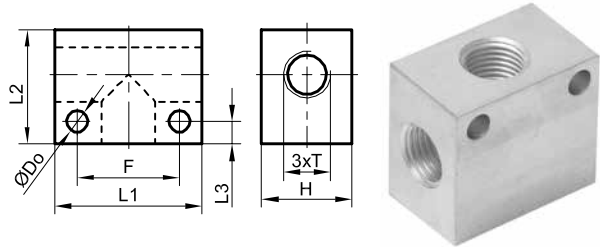

T	B	L	Order no.
R1/8	8	35	80.0303.18Z
R1/4	11	47	80.0303.14Z
R3/8	12	52	80.0303.38Z
R1/2	14	58	80.0303.12Z

Material: nickel-plated brass

### 80.0303 FOUR WAY CONNECTOR WITH MALE THREADS

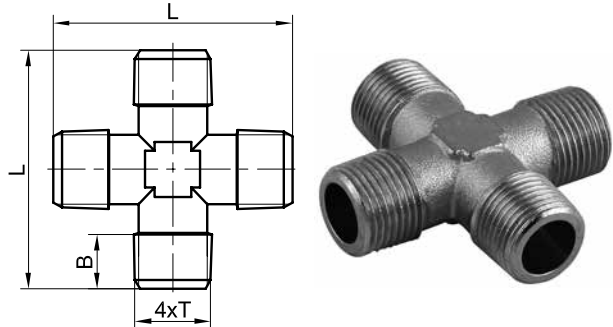

T1	T2	B1	B2	L	Order no.
G1/8	R1/8	8.5	8	39	80.0302.18
G1/4	R1/4	11	11	50	80.0302.14
G3/8	R3/8	12	11.5	56	80.0302.38
G1/2	R1/2	15	14	64	80.0302.12

Material: nickel-plated brass

### 80.0302 FOUR WAY CONNECTOR WITH MFFF THREADS

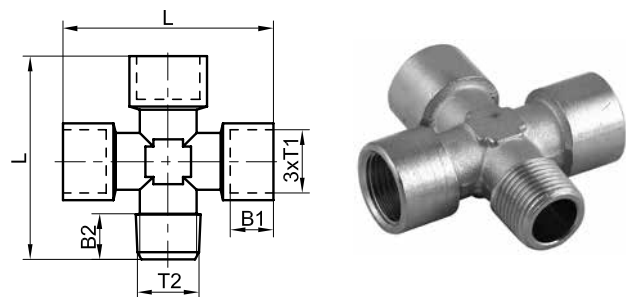

T	B	L	Order no.
G1/8	8	39	80.0300.18W
G1/4	11	50	80.0300.14W
G3/8	12	56	80.0300.38W
G1/2	15	64	80.0300.12W

Material: nickel-plated brass

### 80.0300 FOUR WAY CONNECTOR WITH FEMALE THREADS

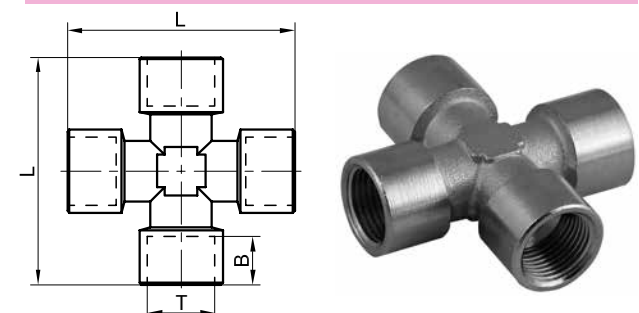



### 80.0206

FOUR WAY CONNECTOR BODY  
WITH FEMALE THREADS

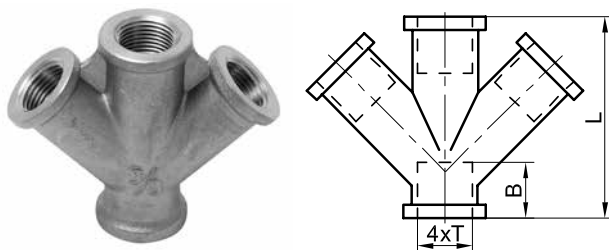

T	B	L	Order no.
G3/8	17	61	80.0206.38
G1/2	17	67	80.0206.12

Material: nickel-plated brass

### 60.0158

FOUR WAY CONNECTOR

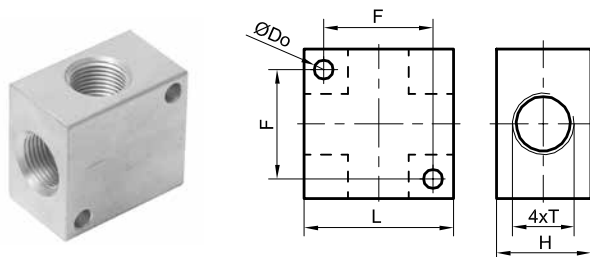

T	ØDo	F	H	L	Order no.
M5	-	-	10	19	60.0158.05
G1/8	4.5	19	17	27	60.0158.18
G1/4	5.5	25	22	36	60.0158.14
G3/8	5.5	30	26	41	60.0158.38
G1/2	5.5	38	32	50	60.0158.12
G3/4	6.5	44	38	60	60.0158.34

Material: aluminium

### 80.0501

SINGLE-SIDED MANIFOLD



T1	T2	ØDo	F	H1	H2	L1	L2	L3	n	Order no.
G1/4	G1/8	4.5	50	24	18	65	30	17.5	2	80.0501.14.1802
G1/4	G1/8	4.5	30	24	18	95	30	17.5	3	80.0501.14.1803
G1/4	G1/8	4.5	60	24	18	125	30	17.5	4	80.0501.14.1804
G1/4	G1/8	4.5	90	24	18	155	30	17.5	5	80.0501.14.1805
G1/4	G1/8	4.5	120	24	18	185	30	17.5	6	80.0501.14.1806
G3/8	G1/4	5.5	60	30	22	76	36	20	2	80.0501.38.1402
G3/8	G1/4	5.5	36	30	22	112	36	20	3	80.0501.38.1403
G3/8	G1/4	5.5	72	30	22	148	36	20	4	80.0501.38.1404
G3/8	G1/4	5.5	106	30	22	184	36	20	5	80.0501.38.1405
G3/8	G1/4	5.5	144	30	22	220	36	20	6	80.0501.38.1406
G1/2	G3/8	5.5	72	35	26	90	40	25	2	80.0501.12.3802
G1/2	G3/8	5.5	40	35	26	130	40	25	3	80.0501.12.3803
G1/2	G3/8	5.5	80	35	26	170	40	25	4	80.0501.12.3804
G1/2	G3/8	5.5	120	35	26	210	40	25	5	80.0501.12.3805
G1/2	G3/8	5.5	160	35	26	250	40	25	6	80.0501.12.3806

Material: aluminium

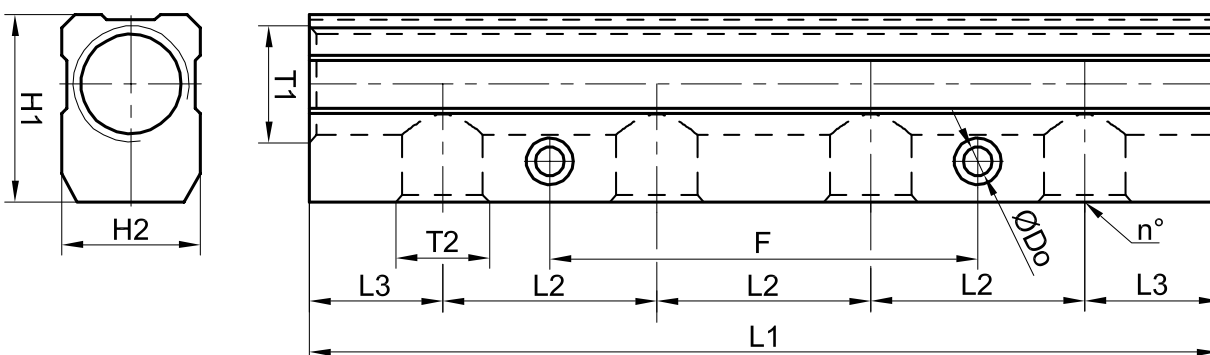

T1	T2	ØDo	F	H1	H2	L1	L2	L3	n	Order no.
G1/4	G1/8	4.5	50	30	18	65	30	17.5	2	80.0502.14.1802
G1/4	G1/8	4.5	30	30	18	95	30	17.5	3	80.0502.14.1803
G1/4	G1/8	4.5	58	30	18	125	30	17.5	4	80.0502.14.1804
G1/4	G1/8	4.5	88	30	18	155	30	17.5	5	80.0502.14.1805
G1/4	G1/8	4.5	120	30	18	185	30	17.5	6	80.0502.14.1806
G3/8	G1/4	5.5	60	38	22	76	36	20	2	80.0502.38.1402
G3/8	G1/4	5.5	36	38	22	112	36	20	3	80.0502.38.1403
G3/8	G1/4	5.5	72	38	22	148	36	20	4	80.0502.38.1404
G3/8	G1/4	5.5	107	38	22	184	36	20	5	80.0502.38.1405
G3/8	G1/4	5.5	144	38	22	220	36	20	6	80.0502.38.1406
G1/2	G3/8	5.5	75	44	26	90	40	25	2	80.0502.12.3802
G1/2	G3/8	5.5	40	44	26	130	40	25	3	80.0502.12.3803
G1/2	G3/8	5.5	80	44	26	170	40	25	4	80.0502.12.3804
G1/2	G3/8	5.5	120	44	26	210	40	25	5	80.0502.12.3805
G1/2	G3/8	5.5	157	44	26	250	40	25	6	80.0502.12.3806

Material: aluminium

## 80.0502 DOUBLE-SIDED MANIFOLD

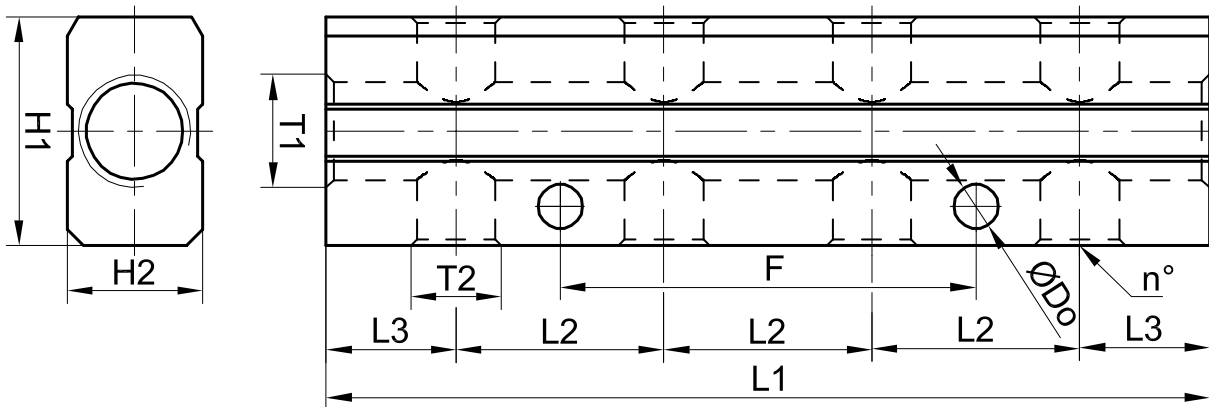

T	B	L	SW	Order no.
R1/8	7.5	19.5	11	81.0120.18
R1/4	11	27	14	81.0120.14
R3/8	11.5	28	17	81.0120.38
R1/2	14	33.5	22	81.0120.12

Material: stainless steel ASI 315

## 81.0120 STRAIGHT CONNECTOR

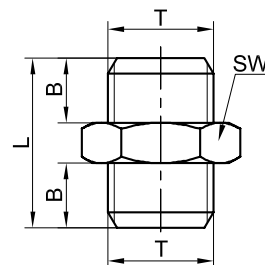

# FITTINGS, ACCESSORIES AND HOSES

## threaded connectors



### 81.0124

MUFF

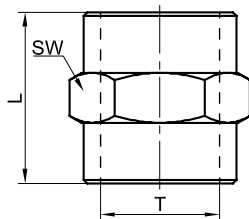

T	L	SW	Order no.
G1/8	15	14	81.0124.18
G1/4	22	17	81.0124.14
G3/8	24	22	81.0124.38
G1/2	30	26	81.0124.12

Material: stainless steel ASI 315

### 81.0200.01

ELBOW WITH FM THREADS

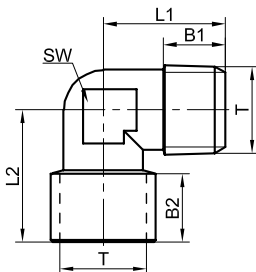

T	B1	B2	L1	L2	SW	Order no.
R1/8	7.5	8.5	18	21	10	81.0200.01.18
R1/4	11	11	24	25.5	12	81.0200.01.14
R3/8	11.5	12	27	28	15	81.0200.01.38
R1/2	14	15	29.5	32	20	81.0200.01.12

Material: stainless steel ASI 315

### 81.0201

T-CONNECTOR WITH FEMALE THREADS

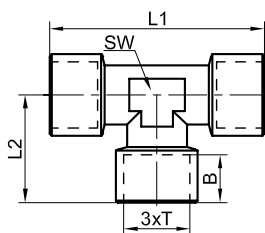

T	B	L1	L2	SW	Order no.
G1/8	8.5	37	18.5	12	81.0201.18
G1/4	11	49	24.5	12	81.0201.14
G3/8	12	54	27	15	81.0201.38
G1/2	15	64	32	20	81.0201.12

Material: stainless steel ASI 315

### 81.0204

ELBOW WITH FEMALE THREADS

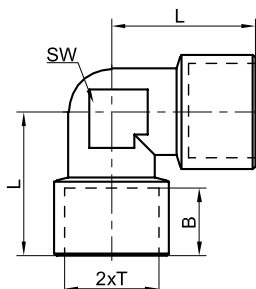

T	B	L	SW	Order no.
G1/8	8.5	21	10	81.0204.18
G1/4	11	25.5	12	81.0204.14
G3/8	12	28	15	81.0204.38
G1/2	15	32	20	81.0204.12

Material: stainless steel ASI 315

T	HOSE		B	L	SW	Order no.
	$\varnothing Dw$					
M5	4	2	4	18	8	80.1500.M5.04
M5	6	4	4	18	8	80.1500.M5.06

Material: brass

### 80.1500

M5 NOZZLE WITH SOCKET END

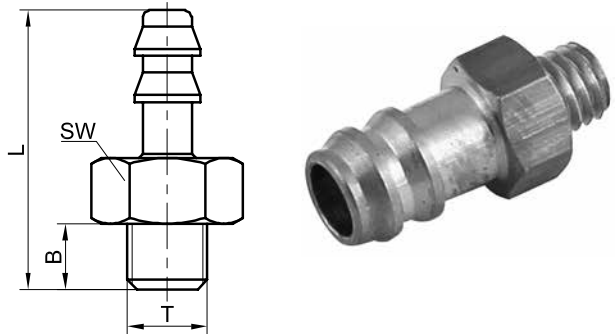

HOSE		L	Order no.
$\varnothing Dw1$	$\varnothing Dw2$		
2	2	20	80.1504.0202
4	4	22	80.1504.0404
4	6	22	80.1504.0604
6	8	22	80.1504.0606

Material: brass

### 80.1504

DOUBLE SOCKET CONNECTOR

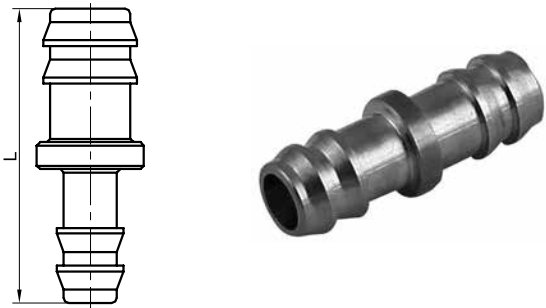

HOSE	L	Order no.
$\varnothing Dw$		
2	16	80.1513.02
4	22	80.1513.04
6	22	80.1513.06

Material: brass

### 80.1513

SOCKET CONNECTOR TYPE L

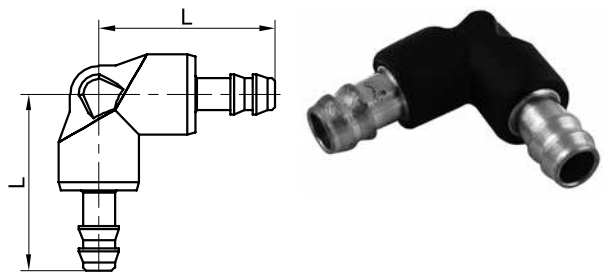

HOSE	L1	L2	Order no.
$\varnothing Dw$			
2	32	16	80.1523.02
4	44	22	80.1523.04
6	44	22	80.1523.06

Material: brass

### 80.1523

SOCKET CONNECTOR TYPE T

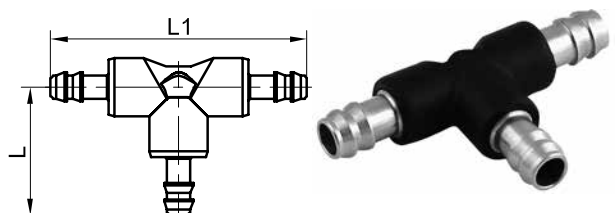

### 80.0239Z

MALE THREAD NOZZLE

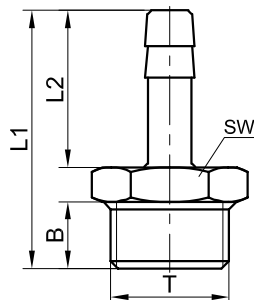

T	HOSE	B	L1	L2	SW	Order no.
	ØDw					
G1/8	4	9	41	27	14	80.0239.1804Z
G1/8	6	9	48	27	14	80.0239.1806Z
G1/8	9	10	48	33	14	80.0239.1809Z
G1/4	4	10	48	33	17	80.0239.1404Z
G1/4	6	10	48	33	17	80.0239.1406Z
G1/4	9	10	48	33	17	80.0239.1409Z
G1/4	13	10	48	33	19	80.0239.1413Z
G3/8	4	10	48	33	19	80.0239.3804Z
G3/8	6	10	48	33	19	80.0239.3806Z
G3/8	9	10	48	33	19	80.0239.3809Z
G3/8	13	10	48	33	19	80.0239.3813Z
G3/8	20	12	36	19	21	80.0239.3820Z
G1/2	6	10	48	33	24	80.0239.1206Z
G1/2	9	10	48	33	24	80.0239.1209Z
G1/2	13	10	48	33	24	80.0239.1213Z
G1/2	17	10	48	33	24	80.0239.1217Z
G1/2	20	11	54	36	24	80.0239.1220Z
G3/4	13	15	52	28	32	80.0239.3413Z
G3/4	16	16	43	19	27	80.0239.3416Z
G3/4	19	13	40	19	27	80.0239.3419Z
G3/4	25	15	41	19	27	80.0239.3425Z
G1	19	12	51	31	38	80.0239.1019Z
G1	25	11	50	34	38	80.0239.1025Z

Material: brass / nickel-plated brass

### 80.0239W

FEMALE THREAD NOZZLE

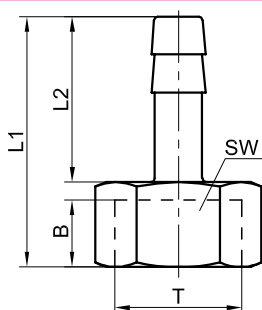

T	HOSE	B	L1	L2	SW	Order no.
	ØDw					
G1/8	6	8	30	19.5	14	80.0239.1806W
G1/8	8	8	35	25	12	80.0239.1808W
G1/4	6	9	36	25	15	80.0239.1406W
G1/4	8	11	32	19.5	17	80.0239.1408W
G1/4	10	9	36	25	15	80.0239.1410W
G1/4	13	9	40	29	15	80.0239.1413W
G3/8	6	9	36	25	19	80.0239.3806W
G3/8	8	9	36	25	19	80.0239.3808W
G3/8	10	11	33	19	20	80.0239.3810W
G3/8	13	9	40	29	19	80.0239.3813W
G1/2	6	11	39	25	23	80.0239.1206W
G1/2	8	11	39	25	23	80.0239.1208W
G1/2	10	11	39	25	23	80.0239.1210W
G1/2	13	11	44	29	23	80.0239.1213W

Material: brass / nickel-plated brass

### 80.0240

ANGLE FITTING

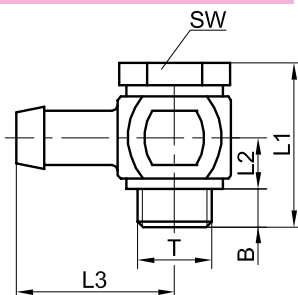

T	HOSE	B	L1	L2	L3	SW	Order no.
	ØDw						
G1/8	6	5	27	7.5	26	14	80.0240.1806
G1/4	6	6	29	7.5	28	17	80.0240.1406
G1/4	9	6	29	7.5	28	17	80.0240.1409
G3/8	6	8	31	7.5	29	22	80.0240.3806
G3/8	9	8	32	7.5	29	22	80.0240.3809

Material: brass / nickel-plated brass

### 80.0034.01

STRAIGHT CONNECTOR

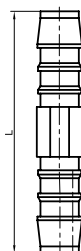

HOSE	L	Order no.
ØDw		
4	35	80.0034.01.04
6	49	80.0034.01.06
8	56	80.0034.01.08
10	63	80.0034.01.10
12	73	80.0034.01.12
16	76	80.0034.01.16
19	76	80.0034.01.19

Construction materials: POM

HOSE		L	Order no.
ØDw1	ØDw2		
6	4	44	80.0034.02.0604
8	6	54	80.0034.02.0806
10	6	57	80.0034.02.1006
10	8	61	80.0034.02.1008
12	8	63	80.0034.02.1208

Construction materials: POM

### 80.0034.02

#### REDUCER CONNECTOR

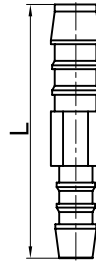

HOSE	L1	L2	Order no.
ØD			
4	20	18	80.0034.03.04
6	26	25	80.0034.03.06
8	30	29	80.0034.03.08
10	34	31	80.0034.03.10
12	36	35	80.0034.03.12
16	45	41	80.0034.03.16
19	46	44	80.0034.03.19

Construction materials: POM

### 80.0034.03

#### ANGLE CONNECTOR

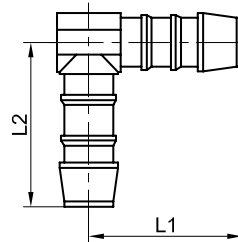

HOSE	L1	L2	Order no.
ØDw			
4	35	19.5	80.0034.04.04
6	50	26	80.0034.04.06
8	58	30	80.0034.04.08
10	62.5	33.5	80.0034.04.10
12	69	36	80.0034.04.12
16	81	45	80.0034.04.16
19	87	46	80.0034.04.19

Construction materials: POM

### 80.0034.04

#### T-CONNECTOR

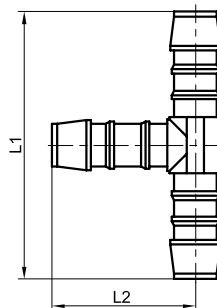

HOSE	L	α	Order no.
ØDw			
4	26	90°	80.0034.05.04
6	44	90°	80.0034.05.06
8	51	90°	80.0034.05.08
10	54	90°	80.0034.05.10
12	64	90°	80.0034.05.12
16	67	90°	80.0034.05.16
19	72	90°	80.0034.05.19

Construction materials: POM

### 80.0034.05

#### Y-CONNECTOR

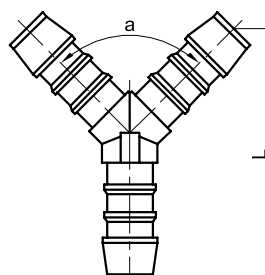

### TECHNICAL SPECIFICATIONS

<b>Maximum operating pressure:</b>	20 bar
<b>Medium:</b>	compressed air or other non-aggressive gas, non-aggressive liquids (including vacuum)
<b>Operating temperature range:</b>	0 to +80°C
<b>Materials:</b>	
<b>Body I</b>	- brass
<b>Slider</b>	- brass
<b>Body II</b>	- brass
<b>Spring</b>	- spring steel
<b>Head</b>	- nickel-plated brass
<b>Sealing ring</b>	- NBR 70
<b>Spring</b>	- spring steel
<b>Sealing ring</b>	- NBR 70
<b>Balls</b>	- bearing steel
<b>Nozzle</b>	- brass

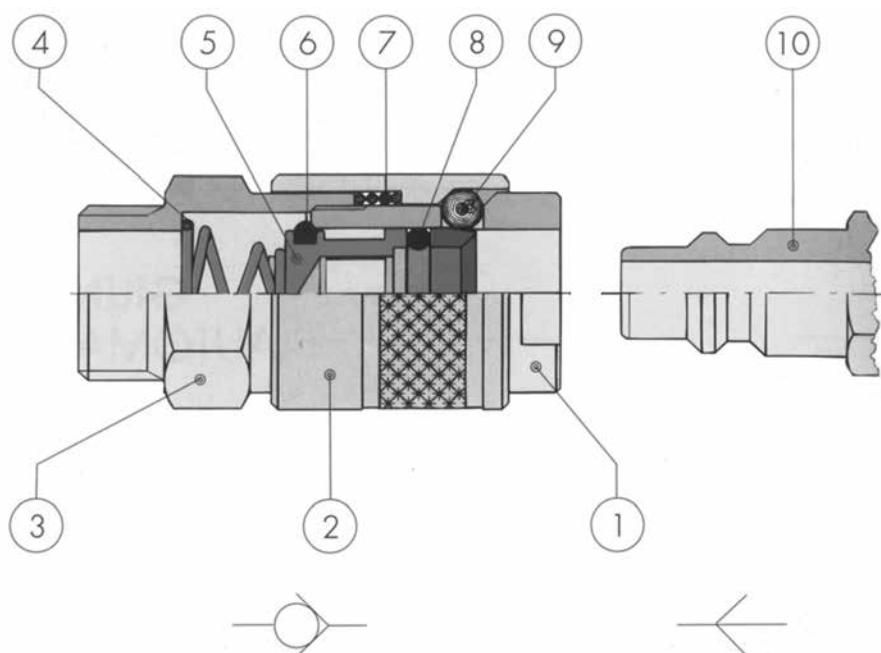

1) **Body I**, 2) **Slider**, 3) **Body II**, 4) **Spring**, 5) **Head**, 6) **Seal. ring**, 7) **Spring**, 8) **Seal. ring**, 9) **Balls**, 10) **Nozzle**

Quick couplings and nozzles are used for the quick connection and disconnection of hoses in pneumatic installations. After the hose is disconnected, the working medium flow is cut off, which does not cause pressure loss in the system.

Quick couplings and nozzles are particularly suitable for the connection of pneumatic tools and for use in car repair shops.

T	B	ØD	L	SW	Order no.
M5	7	10	26	9	80.0243.27.05Z
G1/8	7	10	28	11	80.0243.27.18Z

Material: brass

## 80.0243.27

QUICK COUPLING DN 2.7 WITH MALE THREAD

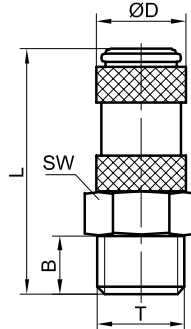

T	B	ØD	L	SW	Order no.
M5	7	10	26	9	80.0243.27.05W
G1/8	7	10	28	11	80.0243.27.18W

Material: brass

## 80.0243.27

QUICK COUPLING DN 2.7 WITH FEMALE THREAD

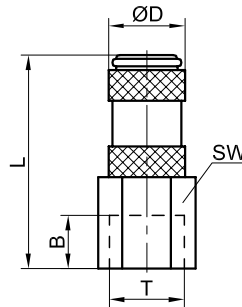

HOSE		ØD1	ØD2	L1	L2	SW	Order no.
ØDz	ØDw						
6	4	10	9	34	14	9	80.0243.27.0604

Material: brass

## 80.0243.27

QUICK COUPLING DN 2.7 WITH HOSE FITTING

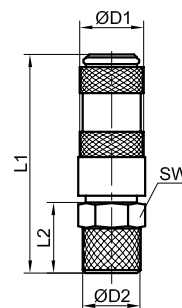

HOSE	Ø	L2	L1	Order no.
ØDw				
3	10	8	35	80.0243.27.03
4	10	8	35	80.0243.27.04

Material: brass

## 80.0243.27

QUICK COUPLING DN 2.7 WITH END HOSE FITTING

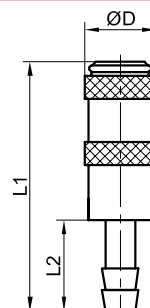



# FITTINGS, ACCESSORIES AND HOSES

quick couplings and nozzles



## 80.0244.27

NOZZLE DN 2.7 WITH MALE THREAD

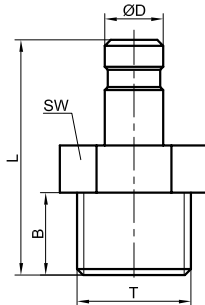

T	B	ØD	L	SW	Order no.
M5	5	5	17	7	80.0244.27.05Z
G1/8	7	5	20	11	80.0244.27.18Z

Material: brass

## 80.0244.27

NOZZLE DN 2.7 WITH FEMALE THREAD

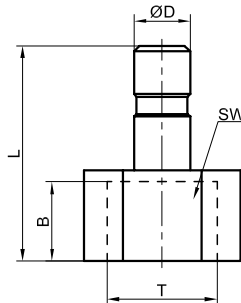

T	B	ØD	L	SW	Order no.
M5	5	5	17	8	80.0244.27.05W
G1/8	7	5	19	12	80.0244.27.18W

Material: brass

## 80.0244.27

NOZZLE DN 2.7 WITH HOSE FITTING

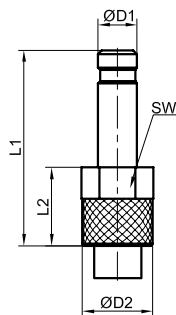

HOSE		ØD1	ØD2	L1	L2	SW	Order no.
ØDz	ØDw						
6	4	5	9	25	11	8	80.0244.27.0604

Material: brass

## 80.0244.27

NOZZLE DN 5 WITH HOSE END FITTING

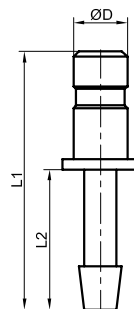

HOSE		ØD	L1	L2	Order no.
ØDz	ØDw				
4	4	5	24	13	80.0244.27.04

Material: brass

T	B	ØD	L	SW	Order no.
G1/8	7	17	36	14	80.0243.50.18Z
G1/4	9	17	38	17	80.0243.50.14Z
G3/8	9	17	38	19	80.0243.50.38Z

Material: brass

## 80.0243.50

QUICK COUPLING DN 5  
WITH MALE THREAD

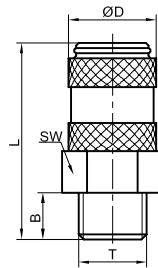

T	B	ØD	L	SW	Order no.
G1/8	8	16	36	14	80.0243.50.18W
G1/4	8	16	38	17	80.0243.50.14W
G3/8	8	16	39	19	80.0243.50.38W

Material: brass

## 80.0243.50

QUICK COUPLING DN 5  
WITH FEMALE THREAD

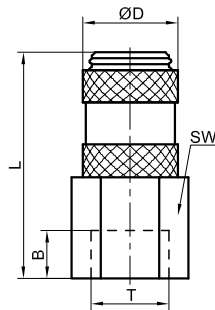

HOSE		ØD1	ØD2	L1	L2	SW	Order no.
ØDz	ØDw						
6	4	16	12	42	11	12	80.0243.50.0604
8	6	16	14	42	11	14	80.0243.50.0806

Material: brass

## 80.0243.50

QUICK COUPLING DN 5  
WITH HOSE FITTING

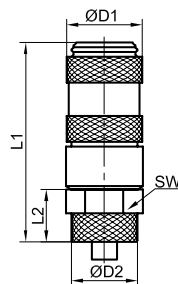

HOSE	ØD	L1	L2	Order no.
ØDw				
4	16	46	17	80.0243.50.04
6	16	46	17	80.0243.50.06
9	16	46	17	80.0243.50.09

Material: brass

## 80.0243.50

QUICK COUPLING DN 5  
WITH HOSE END FITTING

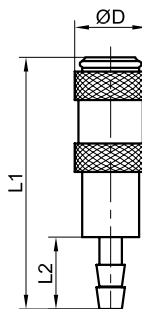

# FITTINGS, ACCESSORIES AND HOSES

quick couplings and nozzles



## 80.0244.50

NOZZLE DN 5 WITH MALE THREAD

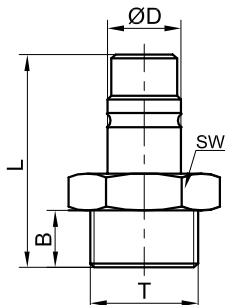

T	B	ØD	L	SW	Order no.
G1/8	9	9	24	14	80.0244.50.18Z
G1/4	9	9	26	16	80.0244.50.14Z
G3/8	9	9	28	19	80.0244.50.38Z

Material: brass

## 80.0244.50

NOZZLE DN 5 WITH FEMALE THREAD

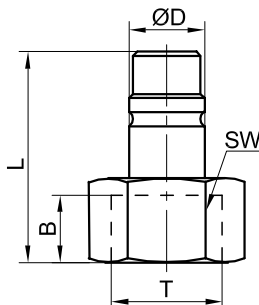

T	B	ØD	L	SW	Order no.
G1/8	7	9	25	14	80.0244.50.18W
G1/4	8	9	25	16	80.0244.50.14W
G3/8	9	9	25	19	80.0244.50.38W

Material: brass

## 80.0244.50

NOZZLE DN 5 WITH HOSE FITTING

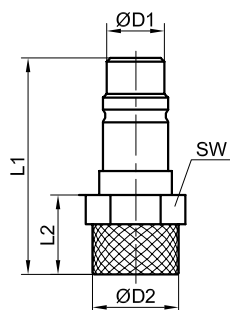

HOSE		ØD1	ØD2	L1	L2	SW	Order no.
ØDz	ØDw						
6	4	9	12	30	11	12	80.0244.50.0604
8	6	9	14	30	11	14	80.0244.50.0806

Material: brass

## 80.0244.50

NOZZLE DN 5 FOR HOSES

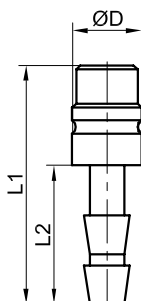

HOSE	ØD	L1	L2	Order no.
ØDw				
4	16	18	31	80.0244.50.04
6	16	18	31	80.0244.50.06
9	16	18	31	80.0244.50.09

Material: brass

T	B	ØD	L	SW	Order no.
G1/4	9	27	43	22	80.0243.72.14Z
G3/8	9	27	43	22	80.0243.72.38Z
G1/2	12	27	46	22	80.0243.72.12Z

Material: brass

## 80.0243.72

QUICK COUPLING DN 7.2  
WITH MALE THREAD

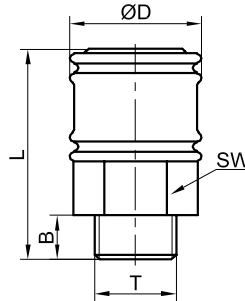

T	B	ØD	L	SW	Order no.
G1/4	10	27	43	22	80.0243.72.14W
G3/8	10	27	43	22	80.0243.72.38W
G1/2	10	27	46	22	80.0243.72.12W

Material: brass

## 80.0243.72

QUICK COUPLING DN 7.2  
WITH FEMALE THREAD

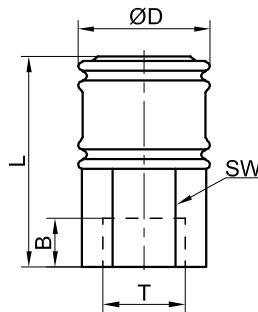

HOSE ØDw	ØD	L1	L2	SW	Order no.
6	27	60	30	22	80.0243.72.06
9	27	60	30	22	80.0243.72.09
13	27	60	30	22	80.0243.72.13

Material: brass

## 80.0243.72

QUICK COUPLING DN 7.2  
WITH HOSE END FITTING

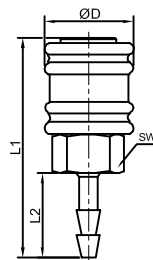

T	B	ØD	L	SW	Order no.
G1/8	8	12	32	14	80.0244.72.18Z
G1/4	8	12	32	14	80.0244.72.14Z
G3/8	9	12	32	19	80.0244.72.38Z
G1/2	9	12	32	19	80.0244.72.12Z

Material: brass

## 80.0244.72

NOZZLE DN 7.2 WITH MALE THREAD

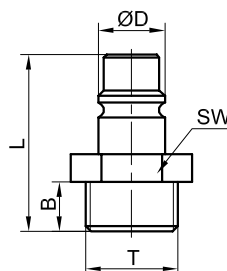

# FITTINGS, ACCESSORIES AND HOSES

quick couplings and nozzles



## 80.0244.72

NOZZLE DN 7.2 WITH FEMALE THREAD

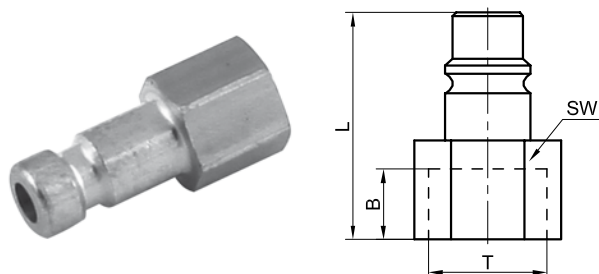

T	B	L	SW	Order no.
G1/8	17	32	9	80.0244.72.18W
G1/4	17	32	9	80.0244.72.14W
G3/8	18	33	10	80.0244.72.38W
G1/2	22	33	10	80.0244.72.12W

Material: brass

## 80.0244.72

NOZZLE DN 7.2 WITH PLASTIC HOSE FITTING

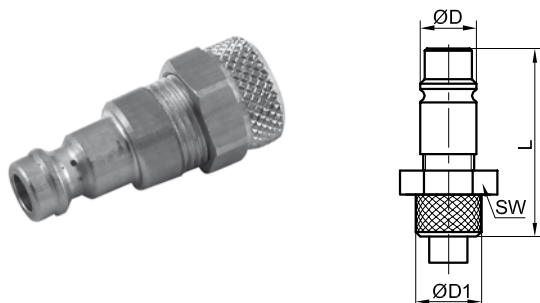

HOSE		ØD	ØD1	L	SW	Order no.
ØDw	ØDz					
4	6	12	14	41	14	80.0244.72.0604
6	8	12	14	40	15	80.0244.72.0806
8	10	12	14	38	17	80.0244.72.1008

Material: brass

## 80.0244.72

NOZZLE DN 7.2 WITH PLASTIC HOSE END FITTING

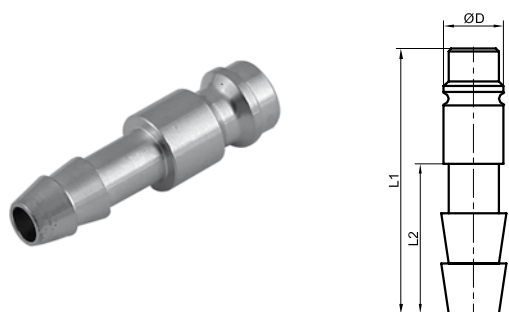

HOSE		ØD	L1	L2	Order no.
ØDw	ØDz				
6	12	53	30	80.0244.72.06	
9	12	53	30	80.0244.72.09	
13	12	53	30	80.0244.72.13	

Material: brass

## 80.0243.72

QUICK COUPLING DN 7.2 WITH HOSE KINK PROTECTION

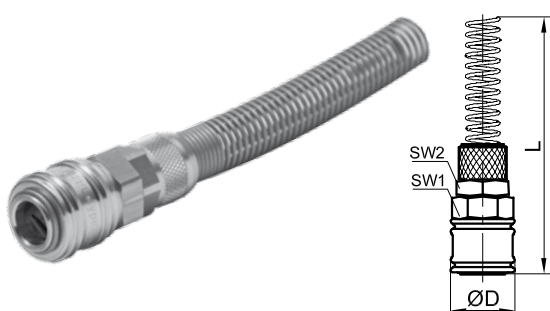

Hose fitting	ØD	L	SW1	SW2	Order no.
6x8	25	132	21	19	80.0243.72.1209
9x12	25	150	21	14	80.0243.72.0805

Material: brass

Hose fitting	ØD	L	SW1	SW2	Order no.
9x12	25	127	14	-	<b>80.0244.72.129S</b>
6x8	25	142	19	17	<b>80.0244.72.085S</b>

Material: brass

## 80.0244.72

QUICK COUPLING DN 7.2 WITH HOSE KINK PROTECTION

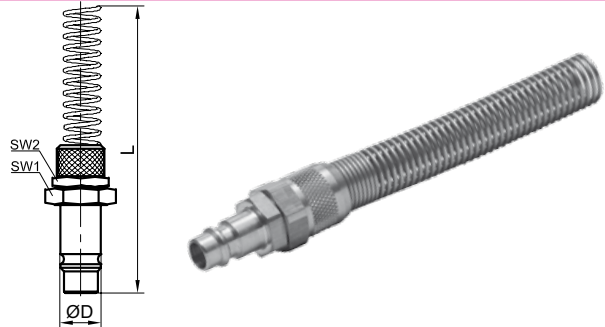

T	B	ØD	L	SW	Order no.
R1/2	17	27	65	24	<b>80.0243.10.12Z</b>
R3/4	17	27	65	27	<b>80.0243.10.34Z</b>

Material: nickel-plated brass

## 80.0243.10 Z

QUICK COUPLING DN 10 WITH MALE THREAD

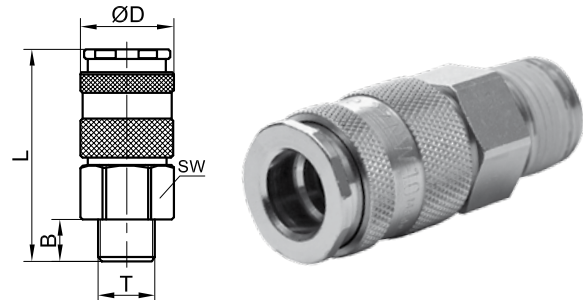

T	B	ØD	L	SW	Order no.
R1/2	12	27	56	24	<b>80.0243.10.12W</b>
R3/4	16	27	60	27	<b>80.0243.10.34W</b>

Material: nickel-plated brass

## 80.0243.10 W

QUICK COUPLING DN 10 WITH FEMALE THREAD

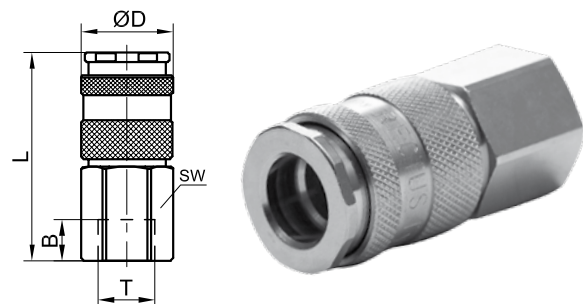

HOSE ØDw	ØD	L1	L2	SW	Order no.
13	27	25	76	24	<b>80.0243.10.13</b>
16	27	25	76	24	<b>80.0243.10.16</b>
19	27	25	76	24	<b>80.0243.10.19</b>

Material: nickel-plated brass

## 80.0243.10

QUICK COUPLING DN 10 WITH HOSE END FITTING

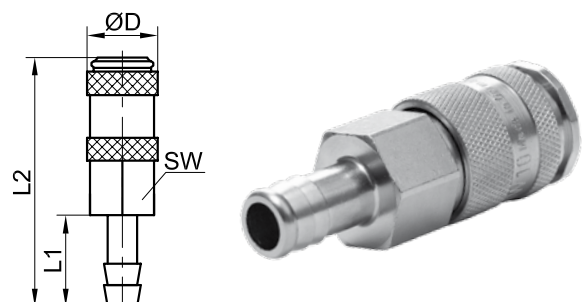

# FITTINGS, ACCESSORIES AND HOSES

quick couplings and nozzles



## 80.0244.10 Z

NOZZLE DN 10  
WITH MALE THREAD

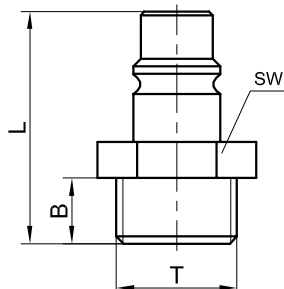

T	B	L	SW	Order no.
R1/2	17	45	22	80.0244.10.12Z
R3/4	19	48	27	80.0244.10.34Z

Material: brass

## 80.0244.10 W

NOZZLE DN 10  
WITH FEMALE THREAD

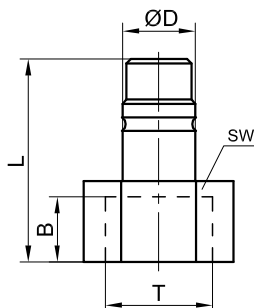
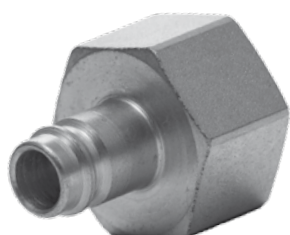

T	B	L	SW	Order no.
R1/2	12	37	24	80.0244.10.12W
R3/4	16	42	32	80.0244.10.34W

Material: brass

## 80.0244.10

NOZZLE DN 10 WITH HOSE END FITTING

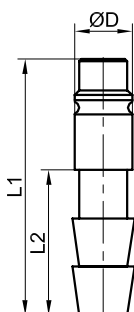

HOSE ØDw	ØD	L1	L2	Order no.
13	15	48	25	80.0244.10.13
16	15	49	25	80.0244.10.16
19	15	49	25	80.0244.10.19

Material: brass

HOSE ØDw	ØD	L1	L2	Order no.
10	57	54	30	<b>80.0220.10</b>
13	57	55	32	<b>80.0220.13</b>
16	57	57	34	<b>80.0220.16</b>
19	57	58	35	<b>80.0220.19</b>
25	57	64	42	<b>80.0220.25</b>
32	57	73	49	<b>80.0220.32</b>
38	59	82	51	<b>80.0220.38</b>

Material: brass

**80.0220**  
CLAW QUICK COUPLING WITH HOSE FITTING

T	ØD	L1	L2	Order no.
G3/8	58	34	8	<b>80.0220.38W</b>
G1/2	58	34	9	<b>80.0220.12W</b>
G3/4	58	34	9	<b>80.0220.34W</b>
G1	58	35	9	<b>80.0220.10W</b>
G1¼	58	39	12	<b>80.0220.114W</b>
G1½	59	41	12	<b>80.0220.112W</b>

Material: brass

**80.0220W**  
CLAW QUICK COUPLING WITH FEMALE THREAD

T	B	ØD	L	Order no.
G3/8	10	57	34	<b>80.0220.38Z</b>
G1/2	11	57	34	<b>80.0220.12Z</b>
G3/4	11	57	34	<b>80.0220.34Z</b>
G1	11	57	34	<b>80.0220.10Z</b>
G1¼	12	58	39	<b>80.0220.114Z</b>
G1½	12	59	41	<b>80.0220.112Z</b>

Material: brass

**80.0220Z**  
CLAW QUICK COUPLING WITH MALE THREAD

ØD	L	Order no.
57	37	<b>80.0220.00</b>

Material: brass

**80.0220.00**  
CLAW QUICK COUPLING PLUG



### 60.0130

PLUG

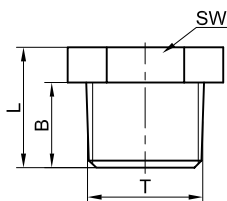

T	B	L	SW	Order no.
M5	6	11	9	60.0130.05
R1/8	8	13	10	60.0130.18
R1/4	11	16	14	60.0130.14
R3/8	12	17	19	60.0130.38
R1/2	15	20	22	60.0130.12
R3/4	16	23	17	60.0130.34

Material: brass

### 80.0132

ALLEN KEY PLUG

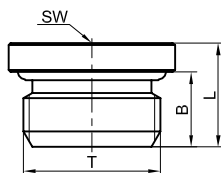

T	B	L	SW	Order no.
M5	4	6	2	80.0132.M5
G1/8	6	8,5	5	80.0132.18
G1/4	8	11	6	80.0132.14
G3/8	9	12,5	8	80.0132.38
G1/2	10	13,5	10	80.0132.12

Material: nickel-plated brass

### 80.0135

PLUG

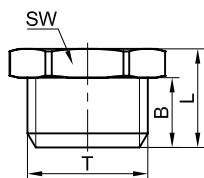

T	B	L	SW	Order no.
M5	4	8	8	80.0135.M5
G1/8	6	10	14	80.0135.18
G1/4	9	13	17	80.0135.14
G3/8	9	13	19	80.0135.38
G1/2	10	14	24	80.0135.12
G3/4	11	16	30	80.0135.34
G1	12	17	40	80.0135.10

Material: nickel-plated brass

### 80.0134

PLUG

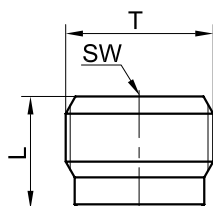

T	L	SW	Order no.
G1/8	8	5	80.0134.18
G1/4	11	6	80.0134.14
G3/8	12	8	80.0134.38
G1/2	14	10	80.0134.12

Material: brass

T	B	L	SW	Order no.
G1/8	7	11	12	80.0131.18
G1/4	11	19	14	80.0131.14
G3/8	11	20	17	80.0131.38
G1/2	14	22	19	80.0131.12

Material: brass

## 80.0131

SCREW-ON PLUG

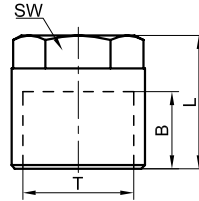

T	B	L	SW	Order no.
G1/8	6	8.5	5	81.0132.18
G1/4	8	11	6	81.0132.14
G3/8	9	12.5	8	81.0132.38
G1/2	10	13.5	10	81.0132.12

Material: stainless steel ASI 315

## 81.0132

ALLEN KEY PLUG

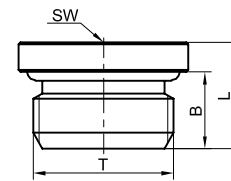

T	T1	B	L	SW	Order no.
R1/4	G1/8	11	16	14	81.6208.1418
R3/8	G1/8	11.5	16.5	17	81.6208.3818
R3/8	G1/4	11.5	16.5	17	81.6208.3814
R1/2	G1/4	14	19.5	22	81.6208.1214
R1/2	G3/8	14	19.5	22	81.6208.1238

Material: stainless steel ASI 315

## 81.6208

REDUCTION

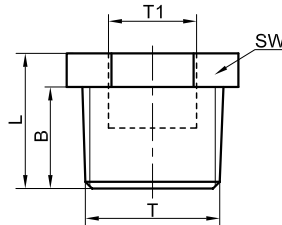

T	B	L	SW	Order no.
G1/8	6	13	13	80.0172.18
G1/4	7	13	15	80.0172.14
G3/8	8	17	19	80.0172.38
G1/2	10	18	24	80.0172.12
G3/4	10	19	30	80.0172.34

Material: brass

## 80.0172

SILENCER

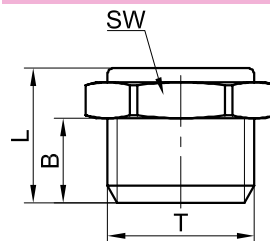

T	B	L	SW	Order no.
M5	4	9	8	80.0173.05
G1/8	6	14	13	80.0173.18
G1/4	8	18	16	80.0173.14
G3/8	7	19	19	80.0173.38
G1/2	10	26	24	80.0173.12
G3/4	10	26	30	80.0173.34
G1	10	26	36	80.0173.100

Material: brass

## 80.0173

SILENCER

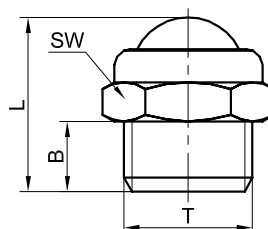

# FITTINGS, ACCESSORIES AND HOSES

accessories for pneumatic systems



## 60.0173

SILENCER

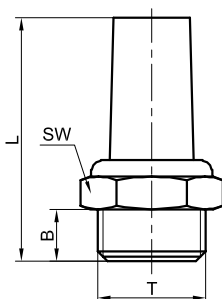

T	B	L	SW	Order no.
M5	5	20	8	60.0173.05
G1/8	6	24	12	60.0173.18
G1/4	7	27	15	60.0173.14
G3/8	9	36	18	60.0173.38
G1/2	10	40	21	60.0173.12
G3/4	11	51	27	60.0173.34

Material: brass

## 80.0174

SILENCER

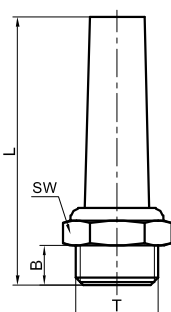

T	B	L	SW	Order no.
G1/8	6	44	13	80.0174.18
G1/4	7	50	16	80.0174.14
G3/8	8	54	19	80.0174.38
G1/2	9	67	24	80.0174.12
G3/4	9	65	30	80.0174.34
G1	12	67	36	80.0174.100

Material: brass

## 80.0174K

SILENCER

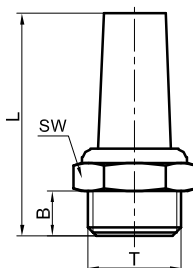

T	B	L	SW	Order no.
M5	4	17	8	80.0174.M5K
G1/8	6	29	13	80.0174.18K
G1/4	7	32	16	80.0174.14K
G3/8	8	40	19	80.0174.38K
G1/2	9	45	24	80.0174.12K
G3/4	10	56	30	80.0174.34K

Material: brass

## 80.0175

ADJUSTABLE DISCHARGE SILENCER

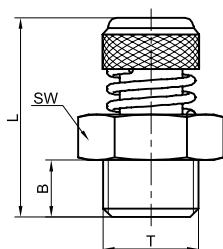

T	B	Lmin	Lmax	SW	Order no.
G1/8	6	26	28	13	80.0175.18
G1/4	8	28	31	15	80.0175.14
G3/8	10	32	35	22	80.0175.38
G1/2	10	32	35	22	80.0175.12

Material: brass

T	L	Order no.
G1/8	4	80.0176.18
G1/4	6	80.0176.14
G3/8	6	80.0176.38
G1/2	9	80.0176.12
G3/4	10	80.0176.34
G1	10	80.0176.100

Material: brass

## 80.0176

SCREW-IN SILENCER

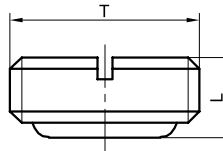

T	B	ØD	L	Order no.
M5	4	6.5	23	80.7070.M5
G1/8	6	12.5	34	80.7070.18
G1/4	7	15.5	42.5	80.7070.14
G3/8	11.5	18.5	67.5	80.7070.38
G1/2	11	23.5	78	80.7070.12
G3/4	15.5	38.5	130	80.7070.34
G1	19.5	49	160	80.7070.100

Material: polyacetal

## 80.7070

SILENCER

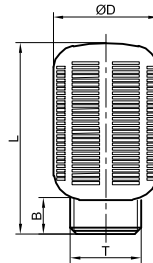

T	HOSE		B	L	SW	Order no.
	ØDz	ØDw				
G1/4	16	8	10	10	19	60.0061.14.1608
G3/8	18	10	12	12	24	60.0061.38.1810
G1/2	26	16	14	14	27	60.0061.12.2616
G3/4	31	20	16	16	32	60.0061.34.3120

Material: zinc-plated steel

## 60.0061

SCREW-ON STRAIGHT FITTING  
FOR METAL BRAIDED HOSES

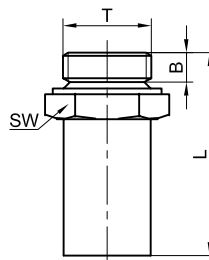

T	HOSE		B	L	SW	Order no.
	ØDz	ØDw				
M16x1.5	16	8	18	40	19	60.0062.14.1608
M20x1.5	18	10	21	43	24	60.0062.38.1810
M24x1.5	26	16	21	47	27	60.0062.12.2616
M30x2	31	20	26	53	32	60.0062.34.3120

Material: zinc-plated steel

## 60.0062

SCREW-ON STRAIGHT FITTING  
FOR METAL BRAIDED HOSES

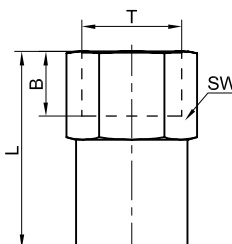

# FITTINGS, ACCESSORIES AND HOSES

accessories for pneumatic systems



## 60.0071

METAL BRAIDED HOSE WITH THREAD

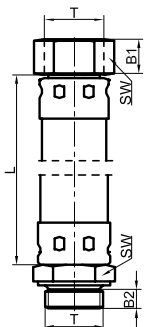

T	B1	B2	L	SW	Order no.
G1/4	14	8	500	19	60.0071.14.00500
G1/4	7	9	1000	19	60.0071.14.01000
G1/4	8	8	1600	19	60.0071.14.01600
G3/8	10	8	500	22	60.0071.38.00500
G3/8	12	8	1000	22	60.0071.38.01000
G3/8	14	8	1600	22	60.0071.38.01600

Material: zinc-plated steel

## 80.0022

BAND CLIP



Diameter adjustment range [mm]	Order no.
8 — 12	80.0022.0812
10 — 16	80.0022.1016
8 — 16	80.0022.0816
12 — 22	80.0022.1222
16 — 27	80.0022.1627
20 — 32	80.0022.2032
25 — 40	80.0022.2540
32 — 50	80.0022.3250
50 — 70	80.0022.5070
70 — 90	80.0022.7090
60 — 80	80.0022.6080
80 — 100	80.0022.80100

## 80.0100

HOSES GUIDE



Hose diameter	Number of hoses	Order no.
6	10	80.0100.06
8	10	80.0100.08
10	6	80.0100.10

**80.1750.0001**  
PLASTIC HOSE CUTTER



Order no.
80.1750.0001

**80.5099.4-14**  
HOSE DISASSEMBLY SPANNER



Order no.
80.5099.4-14

**80.0321**  
PNEUMATIC GUN

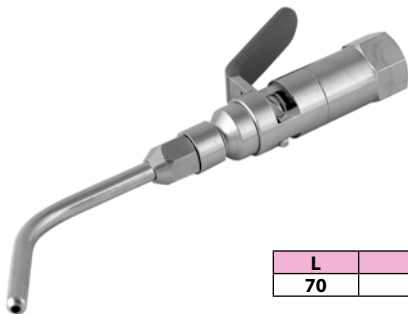

L	Order no.
70	80.0321.90

**80.0310**  
STRAIGHT TIP FOR PNEUMATIC GUN

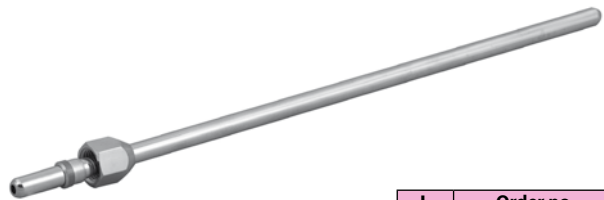

L	Order no.
100	80.0310.100
210	80.0310.210
300	80.0310.300

**80.0311**  
ANGLE TIP FOR PNEUMATIC GUN



L	Order no.
200	80.0311.200
290	80.0311.290

**80.0321.200D**  
PNEUMATIC GUN WITH LONG TIP



L	Order no.
200	80.0321.200D

**80.0321.00K**  
PNEUMATIC GUN WITH SHORT NOZZLE



Order no.
80.0321.00K

**85.0206**  
PUMPING GUN



Order no.
85.0206.60
85.0206.7 with approval

### 60.0050

POLYETHYLENE HOSE



HOSE		Max. working pressure at 20°C [MPa]	Order no.	
ØDz	ØDw		White hose	Blue hose
4	2	0.6	60.0050.0401B	60.0050.0401N
6	4	0.6	60.0050.0601B	60.0050.0601N
8	6	0.6	60.0050.0801B	60.0050.0801N
10	8	0.6	60.0050.1001B	60.0050.1001N
12	8	0.6	60.0050.1202B	60.0050.1202N
16	12	0.6	60.0050.1602B	60.0050.1602N
20	16	0.6	60.0050.2002B	60.0050.2002N

### 60.0051

CALIBRATED POLYETHYLENE HOSE (FOR PUSH-IN FITTINGS)



Polyethylene conduit		Outside diameter [mm]	Inside diameter [mm]	Maximum operating pressure at 23°C [bar]	Minimum bending radius [mm]	Roll length [m]	Operating temperature [°C]	Material	Notes
Blue	White								
60.0051.01N	60.0051.01B	4	2	44	16	100	0°C to +40°C	polyethylene (PE)	The hoses are not UV-resistant, and we do not recommend using them outdoors, where they could be exposed to UV radiation.
60.0051.02N	60.0051.02B	6	4	28	30	100			
60.0051.03N	60.0051.03B	8	6	20	40	100			
60.0051.04N	60.0051.04B	10	8	16	60	50			

In order to obtain the actual pressure resistance, the temperature impact factors listed in the table must be taken into account.

The temperature correction factor for the operating pressure			
0°C	23°C	30°C	40°C
1	1	0.83	0.72

Low density PE hoses are primarily intended for industrial pneumatic and chemical systems. Polyethylene hoses are characterised by high physical and chemical parameters, which allow for a very diverse range of application. PE pipes are used in the construction of systems responsible for the transport of chemicals, vacuum pipelines or broadly defined transport and pressure systems.

PE hoses are lightweight, and due to their characteristic sidewall structure, they guarantee low pressure drops in the transmitted medium.

### 60.0052

PA POLYAMIDE HOSE



Polyamide hose		Outside diameter [mm]	Inside diameter [mm]	Maximum operating pressure at 23°C [bar]	Minimum bending radius [mm]	Roll length [m]	Operating temperature [°C]	Material	Notes
Blue	White								
60.0052.0401N	60.0052.0401B	4	2	44	16	100	-40°C to +80°C	polyamide (PA 12)	Maximum operating temperature for liquids +70°C
60.0052.0601N	60.0052.0601B	6	4	28	30	100			
60.0052.0801N	60.0052.0801B	8	6	20	40	100			
60.0052.1001N	60.0052.1001B	10	8	16	60	50			

In order to obtain the actual pressure resistance, the temperature impact factors listed in the table must be taken into account.

The temperature correction factor for the operating pressure							
0°C	23°C	30°C	40°C	50°C	60°C	70°C	80°C
1	1	0.87	0.74	0.64	0.57	0.52	0.47

PA12 hoses type S40 are mainly intended for industrial pneumatic systems, brake systems and transport of various media.

PA12 in terms of mechanical properties guarantees excellent pressure resistance. Additionally, PA12 has a very good chemical resistance to acids, chlorides, fuels, oils, CFCs and sea water.



### 80.0259.12 PA POLYAMIDE HOSE

Polyamide hose		Outside diameter [mm]	Inside diameter [mm]	Maximum operating pressure at 23°C [bar]	Minimum bending radius [mm]	Roll length [m]	Operating temperature [°C]	Material	Notes
No.	Colour								
80.0259.12BI	White	12	9	20	60	50	-40°C to +80°C	polyamide (PA 12)	Maximum operating temperature for liquids +70°C
80.0259.12NI	Blue	12	9						
80.0259.12CZ	Black	12	9						
80.0259.12CZR	Red	12	9						

In order to obtain the actual pressure resistance, the temperature impact factors listed in the table must be taken into account.

The temperature correction factor for the operating pressure							
0°C	23°C	30°C	40°C	50°C	60°C	70°C	80°C
1	1	0.87	0.74	0.64	0.57	0.52	0.47

PA12 hoses type S40 are mainly intended for industrial pneumatic systems, brake systems and transport of various media.

PA12 in terms of mechanical properties guarantees excellent pressure resistance. Additionally, PA12 has a very good chemical resistance to acids, chlorides, fuels, oils, CFCs and sea water.



### 80.0259.149/150 PU POLYURETHANE HOSE

Polyurethane hose	Outside diameter [mm]	Inside diameter [mm]	Maximum operating pressure at 23°C [bar]	Minimum bending radius [mm]	Roll length [m]	Operating temperature [°C]	Material	Notes
80.0259.149.042	4	2	19	11	200	-20°C to +60°C	PU SH98	- resistant to bending - available in different colours (on request) - for use with push-in connectors
80.0259.150.064	6	4	11	15	100	-20°C to +60°C	PU SH95	
80.0259.150.185	8	5.5	10	25	100	-20°C to +60°C	PU SH95	
80.0259.150.186	8	6	9	35	100	-20°C to +60°C	PU SH98	
80.0259.1501065	10	6.5	10	30	100	-20°C to +60°C	PU SH95	
80.0259.150.108	10	8	7	45	100	-20°C to +60°C	PU SH98	
80.0259.150.128	12	8	9	50	100	-20°C to +60°C	PU SH98	
80.0259.1501610	16	10	16	70	100	-20°C to +60°C	PU SH98	

In order to obtain the actual pressure resistance, the temperature impact factors listed in the table must be taken into account.

The temperature correction factor for the operating pressure						
0°C	23°C	30°C	40°C	50°C	60°C	
1	1	0.87	0.74	0.64	0.57	

Used for industrial robots and pneumatic systems. Used for a variety of applications depending on the function. More flexibility compared to PA facilitates easy assembly of systems. Greater flexibility at low temperatures. Resistant to most oils, fats, hydrocarbons and oxygen.



## 80.0259

TFN TEFLON HOSE



Teflon hose	Outside diameter [mm]	Inside diameter [mm]	Maximum operating pressure at 23°C [bar]	Minimum bending radius [mm]	Roll length [m]	Operating temperature [°C]	Material / hardness	Notes
80.0259.042TFN	4	2	27	20	100	60°C to +260°C	PTFE	Teflon hoses are not intended for the transport of oxygen, saturated steam and electrostatic charges.
80.0259.01TFN	6	4	18	30				
80.0259.02TFN	8	6	14	40				
80.0259.03TFN	10	8	12	60				

In order to obtain the actual pressure resistance, the temperature impact factors listed in the table must be taken into account.

The temperature correction factor for the operating pressure				
-60°C to +40°C	+40°C to +100°C	+100°C to +150°C	+150°C to +200°C	+200°C to +260°C
1	1	0.87	0.74	0.64

PTFE low-pressure hoses are primarily intended for industrial pneumatic and chemical systems for the transport of: paints, oils, water, other water-based compounds and steam. PTFE has good chemical resistance to most compounds, including: acetones, most acids, ketones, dibutyl phthalates, hydroxides, carbon oxides, benzenes, ozone. Teflon has an extremely low friction coefficient.

## 80.0053

PVC REINFORCED HOSE



PVC reinforced hose	Outside diameter [mm]	Inside diameter [mm]	Maximum operating pressure at 23°C [bar]		Roll length [m]	Operating temperature [°C]	Material	Notes
			20°C	40°C				
80.0053.1004	10	4	16	10	50	-10°C to +65°C	PVC with textile reinforcement	- general use for water and gases - poor resistance to oils and petrol - hardens after prolonged contact - do not use for drinking water
80.0053.1206	12	6	22	15	50			
80.0053.1408	14	8	21	15	50			
80.0053.1509	15	9	18	12	50			
80.0053.1610	16	10	17	15	50			
80.0053.185125	18.5	12.5	15	10	50			
80.0053.2013	20	13	14	10	50			
80.0053.2316	23	16	16	8	50			
80.0053.2619	26	19	15	8	50			
80.0053.3424	34	24	6	4	25			
80.0053.4232	42	32	5	4	25			
80.0053.5850	58	50	5	4	25			

Flexible hose, resistant to abrasion, designed for many industries, shows high resistance to UV radiation. When used with liquid oils, there is a risk of flushing out the plasticiser contained in the polyvinyl chloride, which significantly reduces the UV resistance and makes the hose brittle. PVC technical hose can be used to transfer hot water without pressure, is resistant to ageing even in case of long-term storage.

## 80.0001

SPIRAL FLEXIBLE PA POLYAMIDE HOSE



HOSE		Max. operating pressure at 20°C [MPa]	Hose length [m]	Spiral diameter [mm]	Order no.
ØDz	ØDw				
10	8	1	10	110	80.0001.1008.10
10	8	1	15	110	80.0001.1008.15
12	10	1	10	110	80.0001.1210.10
12	10	1	15	110	80.0001.1210.15

## 80.0003

SPIRAL FLEXIBLE PU POLYURETHANE HOSE



HOSE		Max. operating pressure at 20°C [MPa]	Hose length [m]	Spiral diameter [mm]	Order no.
ØDz	ØDw				
8	5	1	4	55	80.0003.0805.04
8	5	1	8	55	80.0003.0805.08
8	5	1	15	55	80.0003.0805.12
12	8	1	4	90	80.0003.1208.04
12	8	1	9	90	80.0003.1208.09
12	8	1	15	90	80.0003.1208.12



We are pleased to present our new line of screw compressors with power capacity from 5.5 to 15 kW. These units were designed for small and medium manufacturing plants, which value reliability and low costs of compressed air production. Our compressors are available in a stand-alone version and on a tank with optional compressed air dryer installation. This enables selecting the optimal solution for your needs. The new range of compressors is distinguished by the applied technical solutions and the resulting advantages:

- Power efficiency through the use of a highly energy-efficient compressor stage
- Reliability and low operating costs due to the quality and durability of the components used and the high quality of the workmanship.
- Ease of use resulting from the design following the “plug & play” and “user friendly” philosophies. Possibility of immediate use of the unit without complicated installation works as well as advanced electronic controller managing and supervising the operation of the unit. Reduced amount of attention that the user has to pay to the production of compressed air in the company.
- High quality of the produced compressed air and very low noise level are further advantages of our units.

The price of the product includes commissioning and training. All units come with a 2-year warranty.

If you are looking for a professional continuous operation compressor for your company, seek no further!

Model	Performance	Dryer + 2 filters (rough, fine)	Tank capacity	Volume db
SK 5.5 P/8	0.85	-	-	68
SKTG 5.5P/8/270	0.85	-	270	68
SKTG 5.5P/8/500	0.85	-	500	68
SKTG 5.5 Combo/8	0.85	WDF 53	500	68
SK 5.5 P/10	0.7	-	-	68
SKTG 5.5P/10/270	0.7	-	270	68
SKTG 5.5P/10/500	0.7	-	500	68
SKTG 5.5 P Combo/10	0.7	WDF 53	500	68
SK 5.5 P/13	0.55	-	-	68
SKTG 5.5P/13/270	0.55	-	270	68
SKTG 5.5P/13	0.55	-	500	68
SKTG 5,5 Combo/13	0.55	WDF 53	500	68
SK 7.5 P/8	1.15	-	-	70
SKTG 7.5 P/8	1.15	-	500	70
SKTG 7,5 P Combo/8	1.15	WDF 100	500	70
SK 7.5 P/10	1	-	-	70
SKTG 7.5 P/10	1	-	500	70
SKTG 7,5 P Combo/10	1	WDF 100	500	70
SK 7.5 P/13	0.85	-	-	70
SKTG 7.5 P/13	0.85	-	500	70
SKTG 7.5 P Combo/13	0.85	WDF 53	500	70
SK 11 P/8	1.65	-	-	71
SKTG 11 P/8	1.65	-	500	71
SKTG 11 P Combo/8	1.65	WDF 155	500	71
SK 11 P/10	1.5	-	-	71
SKTG 11 P/10	1.5	-	500	71
SKTG 11 P Combo/10	1.5	WDF 100	500	71
SK 11 P/13	1.2	-	-	71
SKTG 11 P/13	1.2	-	500	71
SKTG 11 P Combo/13	1.2	WDF 100	500	71
SK 15 P/8	2.25	-	-	73
SKTG 15 P/8	2.25	-	500	73
SKTG 15 P Combo/8	2.25	WDF 155	500	73
SK 15 P/10	2.15	-	-	73
SKTG 15 P/10	2.15	-	500	73
SKTG 15 P Combo/10	2.15	WDF 155	500	73
SK 15 P/13	1.6	-	-	73
SKTG 15 P/13	1.6	-	500	73
SKTG 15 P Combo/13	1.6	WDF 155	500	73

### 85.00HR.

AUTO REEL HR

<b>Design:</b>	enclosed
<b>Construction material:</b>	plastic, resistant to mechanical damage
<b>Operating temperature:</b>	-5°C to +60°C
<b>Type of hose:</b>	polyurethane
<b>Maximum operating pressure:</b>	15 bar
<b>Fixing method:</b>	can be hung on a hook or fixed to a wall, ceiling, or floor
<b>Total size:</b>	220x220x82 mm



### 85.00HR.

AUTO REEL HR

<b>Design:</b>	enclosed
<b>Construction material:</b>	powder-coated steel
<b>Operating temperature:</b>	-5°C to +60°C
<b>Type of hose:</b>	reinforced polyurethane
<b>Maximum operating pressure:</b>	15 bar
<b>Fixing method:</b>	can be fixed to a wall, ceiling, or floor
<b>Total size:</b>	380x330x170 mm



### 80.0260

EXHAUST HOSES:

P2PU- standard

P2PUAE-resistant to microbes and hydrolysis

P2PUAS-antistatic (R<1008 Ω)

<b>Design:</b>	enclosed
<b>Construction material:</b>	powder-coated steel
<b>Operating temperature:</b>	-40°C to +100°C
<b>Type of hose:</b>	clear polyester- polyurethane
<b>Reinforcement:</b>	steel hose spiral
<b>Application:</b>	Lightweight, flexible hose designed to remove oil vapours, dust, sawdust, lightweight bulk materials, etc. Used in the wood, construction and food industries.



## PNEUMATIC TOOLS

- **WRENCHES**

- impact
- ratchet

- **GRINDERS**

- angle
- straight
- oscillating
- orbital

- **DRILLS**

- gun
- straight

- **IMPACT HAMMER DRILLS**

- **IMPACT SOCKETS**



## GAS SPRINGS

- **GAS SPRINGS PUSHING**

- standard
- with a valve
- with chrome-plated piston rod

- **STAINLESS STEEL GAS SPRINGS**

- **GAS SPRINGS PULLING**

- standard
- with a valve

- **ACCESSORIES**

- ball joints
- eyes
- forks
- flat ball joints









## Centrum Produkcyjne Pneumatyki "PREMA" SA

ul. Wapiennikowa 90, 25-101 Kielce

HQ phone.: +48 41 361 95 24

Sales phone.: +48 41 366 95 30

e-mail: [prema@prema.pl](mailto:prema@prema.pl)

### VISIT

our branded outlets  
and online store at

[www.prema.pl](http://www.prema.pl)

### 25-101 KIELCE

ul. Wapiennikowa 90

tel.: +48 41 361 98 39

mobile: +48 693 991 938

e-mail: [sklep@prema.pl](mailto:sklep@prema.pl)

### 40-246 KATOWICE

ul. Porcelanowa 10 (ATAL)

tel./fax: +48 32 258 07 78

mobile: +48 693 724 769

e-mail: [katowice@prema.pl](mailto:katowice@prema.pl)

### 75-137 KOSZALIN

ul. Szczecińska 70

tel./fax: +48 94 343 44 90

mobile: +48 693 991 939

e-mail: [koszalin@prema.pl](mailto:koszalin@prema.pl)

### 35-105 RZESZÓW

ul. Boya Żelenskiego 16

tel./fax +48 17 854 84 10

mobile: +48 693 724 500

e-mail: [rzyszow@prema.pl](mailto:rzyszow@prema.pl)

### 85-236 BYDGOSZCZ

ul. Grunwaldzka 54/1a

tel./fax: +48 52 388 22 79

mobile: +48 697 058 515

e-mail: [bydgoszcz@prema.pl](mailto:bydgoszcz@prema.pl)

### 53-609 WROCŁAW

ul. Fabryczna 10

(Dozamel premises, building B2)

mobile: +48 693 991 929

e-mail: [wroclaw@prema.pl](mailto:wroclaw@prema.pl)

